

Table of Contents

Standard Compression Table of Contents	3
Standard Compression Pictorial Index	5
Standard Compression Introduction	6

Quick Reference Guides

ACSR Compression Accessories Quick Reference Guide	7
AAC Compression Accessories Quick Reference Guide	9
AAAC and ACAR Compression Accessories Quick Reference Guide	11
EHS ACSR, Ground Wire, Alumoweld, AWAC Quick Reference Guide	13
Standard Compression Catalog Numbering System	14

ACSR Accessories

Single Tongue Dead Ends – 33100 Series	15
Double Tongue Dead Ends – 33300 Series	18
Single Tongue Dead Ends, Adjustable Clevis – 43600 Series	21
Double Tongue Dead Ends, Adjustable Clevis – 43800 Series	24
Compression Joints – 33000 Series	27
Compression Joints – Jiffy Joints – 7500 Series	30
Repair Sleeves – 5200 Series	31
Jumper Connectors – 5000 Series	34
Straight Terminal Connectors – 5600 Series	37
15° Terminal Connectors – 5100 Series	40
90° Terminal Connectors – 5800 Series	43
Open Run Tee Connectors – 5500 Series	46
Open Run Tee Taps – 5300 Series	49

EHS ACSR Accessories

Single Tongue Dead Ends – 33100 Series	53
Compression Joints – 43000 Series	55

AAC Accessories

Single Tongue Dead Ends – 33500 Series	57
Double Tongue Dead Ends – 33600 Series	60
Single Tongue Dead Ends, Adjustable Clevis – 43200 Series	63
Double Tongue Dead Ends, Adjustable Clevis – 43300 Series	66
Compression Joints – 7000 Series	69
Repair Sleeves – 5200 Series	71
Jumper Connectors – 5000 Series	73
Straight Terminal Connectors – 5600 Series	75
15° Terminal Connectors – 5100 Series	77
90° Terminal Connectors – 5800 Series	80
Open Run Tee Connectors – 5500 Series	82
Open Run Tee Taps – 5300 Series	85

AAAC and ACAR Accessories

Single Tongue Dead Ends – 33700 Series	89
Double Tongue Dead Ends – 43100 Series	91
Single Tongue Dead Ends, Adjustable Clevis – 43400 Series	94
Double Tongue Dead Ends, Adjustable Clevis – 43500 Series	96
Compression Joints – Jiffy Joints – 7500 Series	98
Repair Sleeves – 5200 Series	99
15° Terminal Connectors – 5100 Series	101

AWAC Accessories

Single Tongue Dead Ends – 33200 Series	103
Compression Joints – 7500 and 8500 Series	105

Ground Wire Accessories

Single Tongue Dead Ends – 4500 Series	107
Compression Joints – 4900 Series	108
Jumper Connectors – 5000 Series	110
Straight Terminal Connectors – 5600 Series	111
15° Terminal Connectors – 5100 Series	112
90° Terminal Connectors – 5800 Series	113

Standard Compression Reference Material

AFL Filler Compound Requirements	115
NEMA Standard Pad Size	117
Recommended Tightening Torque for Bolts	118
Steel Dead End Dimensions	
9000 Series – Eyes	119
100 Series – Clevis	119
C6000 Series – Adjustable Clevis	120

Conductor Information Charts

ACSR	121
AAC	123
AAAC	125
ACAR	126

Installation Instructions

Standard Compression Dead Ends – ACSR and ACSS	127
Compression Dead Ends – Adjustable – ACSR	129
Compression Dead Ends – Clevis Adjustment	130
Standard Compression Terminal Connectors	131
Compression Dead Ends – AAC, AAAC, ACAR, AWAC Conductors	133
Compression Dead Ends – EHS ACSR, Alumoweld®, Ground Wire	134

Table of Contents (cont.)

Installation Instructions

Bolted Jumper Connectors – Alumoweld®, Steel Ground Wire	135
Terminal Connectors – Alumoweld, Steel Ground Wire	136
Standard Compression Splice for ACSR Compression Joints	137
Compression Joints – AAC, AAAC, ACAR, AWAC Conductors	139
Compression Joints – Alumoweld, Steel Ground Wire	140
Compression Joints – EHS ACSR Conductors.	141
Repair Sleeves – ACSR, AAC, AAAC, ACAR Conductors	142
Jumper Connectors – ACSR, AAC, AAAC, ACAR, Alumoweld® and Steel Ground Wire Conductors	143
Open Run Tee Taps & Tee Connectors – ACSR, AAC, AAAC, ACAR Conductors. .	144
Open Run Tee Connectors – ACSR, AAC, AAAC, ACAR Conductors.	145

Index

Standard Compression Index	146
--------------------------------------	-----

Pictorial Index

STANDARD COMPRESSION

Dead End – Single Tongue

Eye: pgs. 15, 53, 57, 89, 103, 107 Clevis: pgs. 21, 63, 94

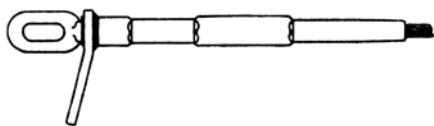

Straight Terminal Connector

pgs. 37, 75, 111



Dead End – Double Tongue

Eye: pgs. 18, 60, 91 Clevis: pgs. 24, 66, 96

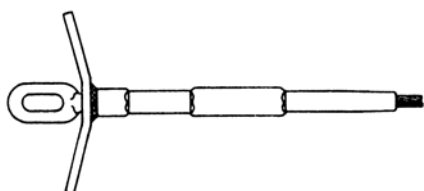

15° Terminal Connector

pgs. 40, 77, 101, 112



Compression Joint

pgs. 27, 30, 55, 69, 98, 105, 108

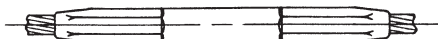

90° Terminal Connector

pgs. 43, 80, 113

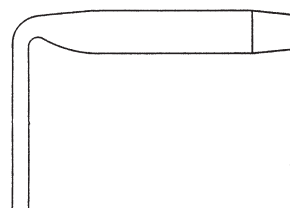

Repair Sleeve

pgs. 31, 71, 99

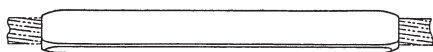

Open Run Tee Connector

pgs. 46, 82

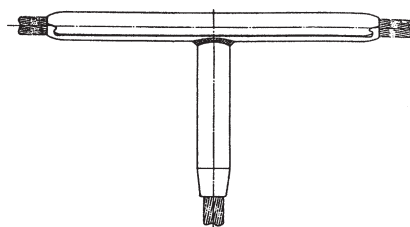

Jumper Connector

pgs. 34, 73, 110



Open Run Tee Tap

pgs. 49, 85

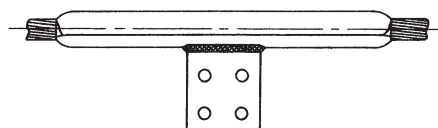

Standard Compression Accessories for Stranded Aluminum Conductors



AFL has the industry's most complete line of compression accessories. This includes dead ends, joints, repair sleeves, jumper connectors, terminal connectors, tee connectors and tee taps. Compression accessories are available in sizes and strandings to fit the following types of conductors: ACSR, AAC, AAAC, ACAR, EHS ACSR, AWAC, Alumoweld® and steel ground wire. For accessory applications of uncommon conductors, contact the AFL Technical Support Team at 1.800.866.7385.

All compression accessories are designed to operate at a temperature 15% to 25% cooler than the conductor. Standard compression accessories are designed for conductor operating temperatures up to 120° C (248° F). For applications exceeding this operating temperature, see the HiTemp® Compression Accessories Catalog.

Dead Ends

Designed in the mid-1920s, the Standard Dead End is a full tension device designed to attach the conductor to the line structure while maintaining the electrical current.

- ANSI C119.4 Class A qualified.
- Designed for full tension use, maintaining a minimum of 95% of the ASTM rated strength of the conductor.
- Steel eye can be oriented in the field prior to installation.
- Tongue is manufactured with a 15° angle.
- Permanent markings for ease of installation and identification.
- Felt washer between the eye and aluminum body provides water protection.

Compression Joints

The Standard Joint is a full tension device designed to join two conductors together in mid-span.

- ANSI C119.4 Class A qualified.
- Designed for full tension use, maintaining a minimum of 95% of the ASTM rated strength of the conductor.
- Permanent markings for ease of installation and identification.

Repair Sleeves

The Repair Sleeve will restore the conductor to 95% of its rated strength, where up to 1/3 of the aluminum strands are damaged.

- ANSI C119.4 Class A qualified.
- Permanent markings for ease of installation and identification.

Terminal Connectors

Terminal Connectors are limited tension devices used to maintain the electrical current through a line junction (also known as paddle, spade, lug or jumper).

- ANSI C119.4 Class A qualified.
- Designed for limited tension use, maintaining a minimum of 40% of the ASTM rated strength of the conductor.
- Standard NEMA pad spacing.
- Both sides of the pad are finished, creating excellent contact surfaces.
- Available in straight, 15 and 90 degree angles.
- Permanent markings for ease of installation and identification.

Quick Reference Guide for Standard Compression Accessories for ACSR Conductors

Conductor				Compression Accessories Catalog Numbers													
Code Word	Size	Standing	Dia.	Dead End Assembly	Dead End Body Single Tongue	Steel Component		15° Terminal Connector	Joint Assembly	Aluminum Joint	Steel Joint	Jumper Connector	Straight Terminal Connector	90° Terminal Connector	Repair Sleeve	Tee Tap Open Run	Tee Connector Open Run
						Steel Eye	Steel Clevis										
Grouse	80.0	8/1	0.367	C33101	8174.4385	—	102.17	5174.438	33005	8074.438	4075.179	5074.438	5674.438	5874.438	5274.2	5374.2	5574.2-74.438
Raven	1/0	6/1	0.398	C33102	8174.438	—	100.14	5174.438	33006	8074.438	4074.148	5074.438	5674.438	5874.438	5274	5374	5574-74.438
Quail	2/0	6/1	0.447	C33103	8174.484	—	100.16	5174.484	33007	8074.484	4074.160	5074.484	5674.484	5874.438	5274	5374	5574-74.436
Pigeon	3/0	6/1	0.502	C33104	8175.547	—	102.17	5175.547	33008	8075.547	4075.179	5075.547	5675.547	5875.547	5275	5375	5575-75.547
Penguin	4/0	6/1	0.563	C33105	8175.609	—	102.20	5175.609	33009	8075.609	4075.228	5075.609	5675.609	5875.609	5275	5375	5575-75.609
Waxwing	266.8	18/1	0.609	C33106	8176.656	—	101.13	5176.656	33010	8076.656	4074.132	5076.656	5676.656	5876.656	5276	5376	5576-76.656
Owl	266.8	6/7	0.633	C33107	8176.688	—	103.22	5176.688	33011	8076.688	4076.221	5076.688	5676.688	5876.688	5276	5376	5576-76.688
Partridge	266.8	26/7	0.642	C33108	8176.688	—	103.25	5176.688	33012	8076.688	4076.246	5076.688	5676.688	5876.688	5276	5376	5576-76.688
Ostrich	300.0	26/7	0.680	C33109	8176.719	—	103.26	5176.719	33081	8076.719	4076.261	5076.719	5676.719	5876.719	5276	5376	5576-76.719
Merlin	336.4	18/1	0.684	C33110	8176.719	—	101.14	5176.719	33013	8076.719	4074.148	5076.719	5676.719	5876.719	5276	5376	5576-76.719
Linnet	336.4	26/7	0.720	C33111	8176.781	—	103.28	5176.781	—	8076.781	4076.277	5076.781	5676.781	5876.781	5276	5376	5576-76.781
Chickadee	397.5	18/1	0.743	C33112	8176.781	—	101.16	5176.781	33016	8020.781	4074.160	5076.781	5676.781	5876.781	5276	5376	5576-76.781
Linnet	336.4	26/7	0.720	E33113	8120.781	9110.277	—	5120.781	33014	8020.781	4010.277	5020.781	5620.781	5820.781	5220.3	5320.3	5520.3-20.781
Oriole	336.4	30/7	0.741	E33114	8120.781	9110.332	—	5120.781	33015	8020.781	4010.332	5020.781	5620.781	5820.781	5220.3	5320.3	5520.3-20.781
Chickadee	397.5	18/1	0.743	E33115	8120.781	9174.160	—	5120.781	33016	8020.781	4074.16	5020.781	5620.781	5820.781	5220.3	5320.3	5520.3-20.781
Brant	397.5	24/7	0.772	E33116	8120.812	9110.261	—	5120.812	33082	8020.812	4010.261	5020.812	5620.812	5820.812	5220.3	5320.3	5520.3-20.812
Ibis	397.5	26/7	0.783	E33117	8120.844	9110.302	—	5120.844	33017	8020.844	4010.302	5020.844	5620.844	6820.844	5220.3	5320.3	5520.3-20.844
Lark	397.5	30/7	0.806	E33118	8120.844	9112.359	—	5120.844	33018	8020.844	4012.359	5020.844	5620.844	5820.844	5220.3	5320.3	5520.3-20.844
Pelican	477.0	18/1	0.814	E33119	8124.875	9175.179	—	5124.875	33020	8024.875	4075.179	5024.875	5624.875	5824.875	5224.3	5324.3	5524.3-24.875
Flicker	477.0	24/7	0.846	E33120	8124.938	9110.295	—	5124.938	33021	8024.938	4010.295	5024.938	5624.938	5824.938	5224.3	5324.3	5524.3-24.938
Hawk	477.0	26/7	0.858	E33121	8124.938	9112.332	—	5124.938	33022	8024.938	4012.332	5024.938	5624.938	5824.938	5224.3	5324.3	5524.3-24.938
Hen	477.0	30/7	0.883	E33122	8124.938C	9212.397	—	5124.938	33023	8024.938	4012.397	5024.938	5624.938	5824.938	5224.3	5324.3	5524.3-24.938
Osprey	556.5	18/1	0.879	E33123	8124.938C	9275.188	—	5124.938	33024	8024.938	4075.188	5024.938	5624.936	5824.938	5224.3	5324.3	5524.3-24.938
Parakeet	556.5	24/7	0.914	E33124	8124.969	9210.316	—	5124.969	33025	8024.969	4010.316	5024.969	5624.969	5824.969	5224.3	5324.3	5524.3-24.969
Dove	556.5	26/7	0.927	E33125	8124.969	9212.359	—	5124.969	33026	8024.969	4012.359	5024.969	5624.969	5824.969	5224.3	5324.3	5524.3-24.969
Eagle	556.5	30/7	0.953	E33126	8127.100	9314.432	—	5127.100	33027	8027.100	4014.432	5027.100	5627.100	5827.100	5227.3	5327.3	5527.3-27.100
Peacock	605.0	24/7	0.953	E33127	8127.100	9212.332	—	5127.100	33028	8027.100	4012.332	5027.100	5627.100	5827.100	5227.3	5327.3	5527.3-27.100
Squab	605.0	26/7	0.966	E33128	8127.100	9212.377	—	5127.100	33029	8027.100	4012.377	5027.100	5627.100	5827.100	5227.3	5327.3	5527.3-27.100
Teal	605.0	30/19	0.994	E33129	8127.106	9314.441	—	5127.106	33030	8027.106	4014.441	5027.106	5727.106	5827.106	5227.3	5327.3	5527.3-27.106
Swift	636.0	36/1	0.930	E33130	8127.100	9274.148	—	5127.100	33083	8027.100	4074.148	5027.100	5627.100	5827.100	5227.3	5327.3	5527.3-27.100
Kingbird	636.0	18/1	0.940	E33131	8127.100	9275.203	—	5127.100	33031	8027.100	4075.228	5027.100	5627.100	5827.100	5227.3	5327.3	5527.3-27.100
Rook	636.0	24/7	0.977	E33132	8127.106	9212.344	—	5127.106	33032	8027.106	4012.344	5027.106	5627.108	5827.106	5227.3	5327.3	5527.3-27.106
Grosbeak	636.0	26/7	0.990	E33133	8127.106	9212.386	—	5127.106	33033	8027.106	4012.386	5027.106	5627.106	5827.106	5227.3	5327.3	5527.3-27.106
Egret	636.0	30/19	1.019	E33134	8127.106	9314.453	—	5127.106	33034	8027.106	4014.453	5027.106	5627.106	5827.106	5227.3	5327.3	5527.3-27.106
Flamingo	666.6	24/7	1.000	E33135	8127.106	9212.351	—	5127.106	33035	8027.106	4012.351	5027.106	5627.106	5827.106	5227.3	5327.3	5527.3-27.106
Stilt	715.5	24/7	1.036	E33136	8130.109	9312.359	—	5130.109	33084	8030.109	4012.359	5030.109	5630.109	5830.109	5230.3	5330.3	5530.3-30.109

Quick Reference Guide for Standard Compression Accessories for ACSR Conductors (cont.)

Conductor				Compression Accessories Catalog Numbers													
Code Word	Size	Standing	Dia.	Dead End Assembly	Dead End Body Single Tongue	Steel Component		15° Terminal Connector	Joint Assembly	Aluminum Joint	Steel Joint	Jumper Connector	Straight Terminal Connector	90° Terminal Connector	Repair Sleeve	Tee Tap Open Run	Tee Connector Open Run
	kcmil	Al/St	in			Steel Eye	Steel Clevis										
Starling	715.5	26/7	1.051	E33137	8130.109	9314.406	—	5130.109	33037	8030.109	4014.406	5030.109	5630.109	5830.109	5230.3	5330.3	5530.3-30.109
Redwing	715.5	30/19	1.081	E33138	8130.116	9316.500	—	5130.116	33038	8030.116	4016.500	5030.116	5630.116	5830.116	5230.3	5330.3	5530.3-30.116
Coot	795.0	36/1	1.040	E33139	8130.109	9374.160	—	5130.109	33039	8030.109	4074.160	5030.109	5630.109	5830.109	5230.3	5330.3	5530.3-30.109
Tern	795.0	45/7	1.063	E33140	8130.116	9310.277	—	5130.116	33040	8030.116	4010.277	5030.116	5630.116	5830.116	5230.3	5330.3	5530.3-30.116
Condor	795.0	54/7	1.093	E33141	8130.116	9312.386	—	5130.116	33042	8030.116	4012.386	5030.116	5630.116	5830.116	5230.1	5330.3	5530.3-30.116
Drake	795.0	26/7	1.108	E33142	8130.116	9314.432	—	5130.116	33043	8030.116	4014.432	5030.116	5630.116	5830.116	5230.3	5330.3	5530.3-30.116
Mallard	795.0	30/19	1.140	E33143	8130.122	9416.516	—	5130.122	33044	8030.122	4016.516	5030.122	5630.122	5830.122	5230.3	5330.3	5530.3-30.122
Cuckoo	795.0	24/7	1.092	E33141	8130.116	9312.386	—	5130.116	33085	8030.116	4012.386	5030.116	5630.116	5830.116	5230.3	5330.3	5530.3-30.116
Ruddy	900.0	45/7	1.131	E33145	8130.122	9310.302	—	5130.122	33047	8030.122	4010.302	5030.122	5630.122	5830.122	5230.3	5330.3	5530.3-30.122
Canary	900.0	54/7	1.162	E33146	8130.122	9414.406	—	5130.122	33046	8030.122	4014.406	5030.122	5630.122	5830.122	5230.3	5330.3	5530.3-30.122
Catbird	954.0	36/1	1.140	E33147	8130.122	9475.179	—	5130.122	33086	8030.122	4075.179	5030.122	5630.122	5830.122	5230.3	5330.3	5530.3-30.122
Rail	954.0	45/7	1.165	E33148	8130.122	9410.302	—	5130.122	33047	8030.122	4010.302	5030.122	5630.122	5830.122	5230.3	5330.3	5530.3-30.122
Cardinal	954.0	54/7	1.196	E33150	8130.125	9414.422	—	5130.125	33049	8030.125	4014.422	5030.125	5630.125	5830.125	5230.3	5330.3	5530.3-30.125
Tanager	1033.5	36/1	1.186	E33151	8130.125	9475.184	—	5130.125	33087	8030.125	4075.179	5030.125	5630.125	5830.125	5230.3	5330.3	5530.3-30.125
Ortolan	1033.5	45/7	1.212	E33152	8134.128	9410.316	—	5134.128	33050	8034.128	4010.316	5034.128	5634.128	5834.128	5234.3	5334.3	5534.3-34.128
Curlew	1033.5	54/7	1.244	E33154	8134.134	9414.432	—	5134.134	33052	8034.134	4014.432	5034.134	5634.134	5834.134	5234.3	5334.3	5534.3-34.134
Bluejay	1113.0	45/7	1.259	E33155	8134.134	9412.332	—	5134.134	33053	8034.134	4012.332	5034.134	5634.134	5834.134	5234.3	5334.3	5534.3-34.134
Bunting	1192.5	45/7	1.302	E33158	8134.138	E9512.344	—	5134.138	33056	8034.138	4012.344	5034.138	5634.138	5834.138	5234.3	5334.3	5534.3-34.138
Bittern	1272.0	45/7	1.345	E33161	8136.144	E9512.351	—	5136.144	33059	8036.144	4012.351	5036.144	5636.144	5836.144	5236.3	5336.3	5536.3-36.144
Pheasant	1272.0	54/19	1.382	E33163	8136.147	E9616.500	—	5136.147	33061	8036.147	4016.500	5036.147	5636.147	5836.147	5236.3	5336.3	5536.3-36.147
Dipper	1351.5	45/7	1.386	E33164	8136.147	E9612.377	—	5136.147	33062	8036.147	4012.377	5036.147	5636.147	5836.147	5236.3	5336.3	5536.3-36.147
Martin	1351.5	54/19	1.424	E33166	8138.150	E9616.500	—	5138.150	33064	8038.150	4016.500	5038.150	5638.150	5838.150	5238.3	5338.3	5538.3-38.150
Bobolink	1431.0	45/7	1.427	E33167	8138.150	E9612.377	—	5138.150	33065	8038.150	4012.377	5038.150	5638.150	5838.150	5238.3	5338.3	5538.3-38.150
Plover	1431.0	54/19	1.465	E33169	8138.156	E9616.516	—	5138.156	33067	8038.156	4016.516	5038.156	5638.156	5838.156	5238.3	5338.3	5538.3-38.156
Nuthatch	1510.5	45/7	1.466	E33170	8138.156	E9612.386	—	5138.156	33068	8038.156	4012.386	5038.156	5638.156	5838.156	5238.3	5338.3	5538.3-38.156
Parrot	1510.5	54/19	1.506	E33172	8140.162	E9616.531	—	5140.162	33070	8040.162	4016.531	5040.162	5640.162	5840.162	5240.3	5340.3	5540.3-40.162
Lapwing	1590.0	45/7	1.504	E33173	8140.162	E9612.397	—	5140.162	33071	8040.162	4012.397	5040.162	5640.162	5840.162	5240.3	5340.3	5540.3-40.162
Falcon	1590.0	54/19	1.545	E33174	8140.162	E9718.546	—	5140.162	33072	8040.162	4018.546	5040.162	5640.162	5840.162	5240.3	5340.3	5540.3-40.162
Chukar	1780.0	84/19	1.602	E33175	8142.178	E9714.453	—	5142.178	33073	8042.178	4014.453	5042.178	5642.178	5842.178	5242.3	5342.3	5542.3-42.178
-----	2034.0	72/7	1.681	E33177	8142.178C	E9814.359	—	5142.178	33075	8042.178	4014.359	5042.178	5642.178	5842.178	5244.3	5344.3	5544.3-44.175
Bluebird	2156.0	84/19	1.762	E33178	8144.184	E9816.516	—	5144.184	33076	8044.184	4016.516	5044.184	5644.184	5844.184	5244.3	5344.3	5544.3-44.184
Kiwi	2167.0	72/7	1.737	E33179	8144.181	E9812.377	—	5144.181	33077	8044.181	4012.377	5044.181	5644.181	5844.181	5244.3	5344.3	5544.3-44.181
Thrasher	2312.0	76/19	1.802	E33181	8144.188	E9814.422	—	5144.188	33078	8044.188	4014.422	5044.188	5644.188	5844.188	5244.3	5344.3	5544.3-44.188
Joree	2515.0	76/19	1.880	E33182	8148.197	E9814.453	—	5148.197	33080	8048.197	4014.453	5048.197	5648.197	5848.197	5248.3	5348.3	5548.3-48.197

Quick Reference Guide for Standard Compression Accessories for AAC Conductors

Conductor				Compression Accessories Catalog Number											
Code Word	Size	Stranding	Dia.	Dead End Assembly	Aluminum Body Single Tongue	Steel Component		15° Terminal Connector	Joint Assembly	Jumper Connector	Straight Terminal Connector	90° Terminal Connector	Repair Sleeve	Tee Tap Open Run	Tee Connector Open Run
	kcmil	Alum.	in			Steel Eye	Steel Clevis								
Poppy	1/0	7	0.368	—	—	—	—	5173.391	7073.391	5073.391	5673.391	5873.391	5274.2	5374.2	5574.2-73.391
Aster	2/0	7	0.414	C33501	7174.438	—	A100X	5174.438	7074.438	5074.438	5674.438	5874.438	5274.0	5374.0	5574-74.438
Phlox	3/0	7	0.464	C33502	7174.484	—	A100X	5174.484	7074.484	5074.484	5674.484	5874.484	5274.0	5374.0	5574-74.484
Oxlip	4/0	7	0.522	C33503	7175.547	—	A102X	5175.547	7075.547	5075.547	5675.547	5875.547	5275.0	5375.0	5575-75.547
Valerian	250.0	19	0.575	C33504	7175.609	—	A102X	5175.609	7075.609	5075.609	5675.609	5875.609	5275.0	5375.0	—
Laurel	266.8	19	0.593	C33504	7175.609	—	A102X	5175.609	7075.609	5075.609	5675.609	5875.609	5275.0	5375.0	5575-75.609
Peony	300.0	19	0.629	C33505	7176.656	—	A101X	5176.656	7076.656	5076.656	5676.656	5876.656	5276.0	5376.0	—
Tulip	336.4	19	0.666	C33506	7176.688	—	A103X	5176.688	7076.688	5076.688	5676.688	5876.688	5276.0	5376.0	5576-76.688
Daffodil	350.0	19	0.679	E33507	7120.719	9100	—	5120.719	7020.719	5020.719	5620.719	5820.719	5276.0	5376.0	—
Canna	397.5	19	0.724	C33508	7176.750	—	A103X	5176.750	7076.750	5076.750	5676.750	5876.750	5276.0	5376.0	5576-76.750
Goldentuft	450.0	19	0.770	E33509	7120.812	9100	—	5120.812	7020.812	5020.812	5620.812	5820.812	5220.3	5320.3	5520.3-20.812
Yarrow	450.0	37		E33509	7120.812	9100	—	5120.812	7020.812	5020.812	5620.812	5820.812	5220.3	5320.3	5520.3-20.812
Cosmos	477.0	19	0.793	E33509	7120.812	9100	—	5120.812	7020.812	5020.812	5620.812	8520.812	5220.3	5320.3	5520.3-20.812
Syringa	477.0	37	0.795	E33509	7120.812	9100	—	5120.812	7020.812	5020.812	5620.812	8520.812	5224.3	5320.3	5520.3-20.812
Cosmos	477.0	19	0.793	E33510	7124.875	9100	—	5124.875	7024.875	5024.875	5624.875	5824.875	5224.3	5324.3	5524.3-24.875
Syringa	477.0	37	0.795	E33510	7124.875	9100	—	5124.875	7024.875	5024.875	5624.875	5824.875	5224.3	5324.3	5524.3-24.875
Zinnia	500.0	19	0.811	E33510	7124.875	9100	—	5124.875	7024.875	5024.875	5624.875	5824.875	5224.3	5324.3	5524.3-24.875
Hyacinth	500.0	37	0.813	E33510	7124.875	9100	—	5124.875	7024.875	5024.875	5624.875	5824.875	5224.3	5324.3	5524.3-24.875
Dahlia	556.5	19	0.856	E33511	7124.938	9100	—	5124.938	7024.938	5024.938	5624.938	5824.938	5224.3	5324.3	5524.3-24.938
Mistletoe	556.5	387	0.858	E33511	7124.938	9100	—	5124.938	7024.938	5024.938	5624.938	5824.938	5224.3	5324.3	5524.3-24.938
Meadowsweet	600.0	37	0.891	E33512	7124.938C	9200	—	5124.938	7024.938	5024.938	5624.938	5824.938	5224.3	5324.3	5524.3-24.938
Orchid	636.0	37	0.918	E33513	7124.969	9200	—	5124.969	7024.969	5024.969	5624.969	5824.969	5224.3	5324.3	5524.3-24.969
Heuchera	650.0	37	0.928	E33513	7124.969	9200	—	5124.969	7024.969	5024.969	5624.969	5824.969	5227.3	5324.3	5524.3-24.969
Flag	700.0	61	0.964	E33514	7127.100	9200	—	5127.100	7027.100	5027.100	5627.100	5827.100	5274.1	5327.3	5527.3-27.100
Violet	715.5	37	0.974	E33515	7127.106	9200	—	5127.106	7027.106	5027.106	5627.106	5827.106	5227.3	5327.3	5527.3-27.106
Nasturtium	715.5	61	0.975	E33515	7127.106	9200	—	5127.106	7027.106	5027.106	5627.106	5827.106	5227.3	5327.3	5527.3-27.106
Petunia	750.0	37	0.997	E33515	7127.106	9200	—	5127.106	7027.106	5027.106	5627.106	5827.106	5227.3	5327.3	5527.3-27.106
Cattail	750.0	61	0.998	E33515	7127.106	9200	—	5127.106	7027.106	5027.106	5627.106	5827.106	5227.3	5327.3	5527.3-27.106
Arbutus	795.0	37	1.026	E33516	7130.109	9300	—	5130.109	7030.109	5030.109	5630.109	5830.109	5230.3	5330.3	5530.3-30.109
Lilac	795.0	61	1.028	E33516	7130.109	9300	—	5130.109	7030.109	5030.109	5630.109	5830.109	5230.3	5330.3	5530.3-30.109
—	800.0	37	1.031	E33516	7130.109	9300	—	5130.109	7030.109	5030.109	5630.109	5830.109	5230.3	5330.3	5530.3-30.109
Heliotrope	800.0	61	1.031	E33516	7130.109	9300	—	5130.109	7030.109	5030.109	5630.109	5830.109	5230.3	5330.3	5530.3-30.109
Snapdragon	900.0	61	1.094	E33517	7130.116	9300	—	5130.116	7030.116	5030.116	5630.116	5830.116	5230.3	5330.3	5530.3-30.116
Magnolia	954.0	37	1.124	E33518	7130.122	9300	—	5130.122	7030.122	5030.122	5630.122	5830.122	5230.3	5330.3	5530.3-30.122
Goldenrod	954.0	61	1.126	E33518	7130.122	9300	—	5130.122	7030.122	5030.122	5630.122	5830.122	5230.3	5330.3	5530.3-30.122
Camellia	1000.0	61	1.152	E33518	7130.122	9300	—	5130.122	7030.122	5030.122	5630.122	5830.122	5230.3	5330.3	5530.3-30.122
Bluebell	1033.5	37	1.170	E33519	7130.122	9400	—	5130.122	7030.122	5030.122	5630.122	5830.122	5230.3	5330.3	5530.3-30.122
Larkspur	1033.5	61	1.172	E33519	7130.122	9400	—	5130.122	7030.122	5030.122	5630.122	5830.122	5230.3	5330.3	5530.3-30.122

Quick Reference Guide for Standard Compression Accessories for AAC Conductors (cont.)

Conductor				Compression Accessories Catalog Number											
Code Word	Size	Stranding	Dia.	Dead End Assembly	Aluminum Body Single Tongue	Steel Component		15° Terminal Connector	Joint Assembly	Jumper Connector	Straight Terminal Connector	90° Terminal Connector	Repair Sleeve	Tee Tap Open Run	Tee Connector Open Run
	kcmil	Alum.	in			Steel Eye	Steel Clevis								
Marigold	1113.0	61	1.216	E33520	7134.128	9400	—	5134.128	7034.128	5034.128	5634.128	5834.128	5234.3	5334.3	5534.3-34.128
Hawthorn	1192.5	61	1.258	E33521	7134.134	9400	—	5134.134	7034.134	5034.134	5634.134	5834.134	5234.3	5334.3	5534.3-34.134
Narcissus	1272.0	61	1.300	E33522	7134.134	E9500	—	5134.134	7034.134	5034.134	5634.134	5834.134	5234.3	5334.3	5534.3-34.134
Columbine	1351.0	61	1.340	E33523	7136.144	E9500	—	5136.144	7036.144	5036.144	5636.144	5836.144	5236.3	5336.3	5536.3-36.144
Carnation	1431.0	61	1.379	E33523	7136.144	E9500	—	5136.144	7036.144	5036.144	5636.144	5836.144	5236.3	5336.3	5536.3-36.144
—	1500.0	91	1.412	E33524	7136.147	E9500	—	5136.147	7036.147	5036.147	5636.147	5836.147	5236.3	5336.3	5536.3-36.147
Gladiolus	1510.5	61	1.187	E33524	7136.147	E9500	—	5136.147	7036.147	5036.147	5636.147	5836.147	5236.3	5336.3	5536.3-36.147
Coreopsis	1590.0	61	1.250	E33525	7138.156	E9600	—	5138.156	7038.156	5038.156	5638.156	5838.156	5238.3	5338.3	5536.3-38.156
Dogwood	1590.0	91	—	E33525	7138.156	E9600	—	5138.156	7038.156	5038.156	5638.156	5838.156	5238.3	5338.3	5538.3-38.156
Jessamine	1750.0	61	1.525	E33526	7140.162	E9600	—	5140.162	7040.162	5040.162	5640.162	5840.162	5240.3	5340.3	5540.3-40.162
Cowslip	2000.0	91	1.630	E33527	7142.178	E9700	—	5142.178	7042.178	5042.178	5642.178	5842.178	5242.3	5342.3	5542.3-42.178
Sagebrush	2250.0	91	1.729	E33528	7144.181	E9800	—	5144.181	7044.181	5044.181	5644.181	5844.181	5244.3	5344.3	5544.3-44.181
—	2300.0	61	—	E33528	7144.181	E9800	—	5144.181	7044.181	5044.181	5644.181	5844.181	5244.3	5344.3	5544.3-44.181
—	2300.0	91	—	E33528	7144.181	E9800	—	5144.181	7044.181	5044.181	5644.181	5844.181	5244.3	5344.3	5544.3-44.181
Lupine	2500.0	91	1.823	E33529	7144.188	E9800	—	5144.188	7044.188	5044.188	5644.188	5844.188	5244.3	5344.3	5544.3-44.188
Bitterroot	2750.0	91	1.912	E33530	7148.197	E9800	—	5148.197	7048.197	5048.197	5648.197	5848.197	5248.3	5348.3	5548.3-48.197
—	2300.0	61	—	E33528	7144.181	E9800	—	5144.181	7044.181	5044.181	5644.181	5844.181	5244.3	5344.3	5544.3-44.181
—	2300.0	91	—	E33528	7144.181	E9800	—	5144.181	7044.181	5044.181	5644.181	5844.181	5244.3	5344.3	5544.3-44.181
Lupine	2500.0	91	1.823	E33529	7144.188	E9800	—	5144.188	7044.188	5044.188	5644.188	5844.188	5244.3	5344.3	5544.3-44.188
Bitterroot	2750.0	91	1.912	E33530	7148.197	E9800	—	5148.197	7048.197	5048.197	5648.197	5848.197	5248.3	5348.3	5548.3-48.197

Quick Reference Guide for Standard Compression Accessories for AAAC and ACAR Conductors

Code Word	Conductor			Compression Accessories Catalog Number						
	Size		Diameter in	Dead End Assembly	Dead End Body Single Tongue	Steel Eye	Adjustable Clevis Assembly	15° Terminal	Compression Joint	Repair Sleeve
	Kcmil	Strand								
Akron	30.58	—	0.198	—	—	—	—	—	7506.250	—
Alton	48.69	—	0.250	—	—	—	—	—	7506.298	—
Ames	77.47	—	0.316	—	—	—	—	—	7509.375	—
Azuza	123.3	—	0.398	—	—	—	—	—	7511.453	5274
—	155.4	4/3	0.447	E33703	7612.484	9000	—	5112.484	—	5274
Anaheim	155.4	7	0.447	E33703	7612.484	9000	—	5112.484	7512.484	5274
—	195.7	4/3	0.502	E33704	7613.542	9000	—	5113.542	—	5275
Amherst	195.7	7	0.502	E33704	7613.542	9000	—	5113.542	7513.542	5275
—	246.9	4/3	0.563	E33705	7613.625	9000	—	5113.625	—	5275
Alliance	246.9	7	0.563	E33705	7613.625	9000	—	5113.625	7513.625	5275
Butte	312.8	19	0.642	E33707	7614.719	9100	—	5114.719	7514.719	5276
—	355.1	—	0.684	—	—	—	—	—	7514.719	5276
Canton	394.5	19	0.721	E33708	7624.781	9200	C43408	5124.781	7524.781	5220.3
—	419.6	—	0.743	—	—	—	—	—	7524.781	5220.3
Cairo	465.4	19	0.783	E33709	7624.875C	9200	C43409	5124.875	7524.875	5220.3
—	503.6	15/4	0.814	E33709	7624.875C	9200	C43409	5124.875	7524.875	5220.3
Darien	559.5	19	0.858	E33710	7627.906	9300	C43410	5127.906	7527.906	5224.3
—	561.1	—	0.862	—	—	—	—	—	7527.906	5224.3
—	587.2	—	0.879	—	—	—	—	—	7527.938	5224.3
—	634.9	12/7	0.914	E33712	7627.100	9200	C43412	5127.100	—	5224.3
—	649.5	18/19	0.928	E33716	7672.100C	9300	C43416	5127.100	—	5224.3
—	649.5	24/13	0.928	E33716	7672.100C	9300	C43416	5127.100	—	5224.3
—	649.5	30/7	0.928	E33716	7672.100C	9300	C43416	5127.100	—	5224.3
Elgin	652.4	19	0.927	E33713	7627.109	9300	C43413	5130.109	7530.109	5224.3
—	657.3	15/4	0.930	E33712	7630.100	9200	C43412	5127.100	—	5224.3
Flint	740.8	37	0.991	E33713	7630.109	9300	—	5130.109	7530.109	5227.3
—	751.4	—	0.609	—	—	—	—	—	7513.688	5276
—	853.7	18/19	1.063	E33717	7630.116	9300	C43417	5130.116	—	5230.3
—	853.7	24/13	1.063	E33717	7630.116	9300	C43417	5130.116	—	5230.3
—	853.7	30/7	1.063	E33717	7634.116	9300	C43417	5130.116	—	5230.3
Greeley	927.2	37	1.108	E33714	7634.122	9300	—	5134.122	7534.122	5230.3
—	927.2	18/19	1.108	E33714	7634.122	9300	C43414	5134.122	—	5230.3
—	927.2	24/13	1.108	E33714	7634.122	9300	C43414	5134.122	—	5230.3
—	927.2	30/7	1.108	E33714	7634.122	9300	C43414	5134.122	—	5230.3
—	1024.5	18/19	1.165	E33714	7634.122	9300	C43414	5134.122	—	5230.3
—	1024.5	24/13	1.165	E33714	7634.122	9300	C43414	5134.122	—	5230.3
—	1024.5	30/7	1.165	E33714	7634.122	9300	C43414	5134.122	—	5230.3
—	1080.6	18/19	1.196	E33716	7634.128	9400	C43415	5134.128	—	5230.3

Quick Reference Guide for Standard Compression Accessories for AAAC and ACAR Conductors (cont.)

Code Word	Conductor			Compression Accessories Catalog Number						
	Size Kcmil	Strand	Diameter in	Dead End Assembly	Dead End Body Single Tongue	Steel Eye	Adjustable Clevis Assembly	15° Terminal	Compression Joint	Repair Sleeve
—	1080.6	24/13	1.196	E33716	7634.128	9400	C43415	5134.128	—	5230.3
—	1080.6	30/7	1.196	E33716	7634.128	9400	C43415	5134.128	—	5230.3
—	1127.0	42/19	1.222	E33723	7638.138	E9500	—	5138.138	—	5234.3
—	1172.3	18/19	1.246	E33715	7634.128	9400	C43415	5134.128	—	5234.3
—	1172.3	24/13	1.246	E33715	7634.128	9400	C43415	5134.128	—	5234.3
—	1180.6	24/13	1.212	E33715	7634.128	9400	C43415	5134.128	—	5234.3
—	1534.0	42/19	1.427	E33718	7638.150	E9600	C43418	5138.150	—	5238.3
—	1534.0	54/7	1.427	E33718	7638.150	E9600	C43418	5138.150	—	5238.3
—	1691.0	—	1.498	E33722	7644.159	E9700	—	5144.159	—	5240.3
—	1700.0	42/19	1.502	E33719	7640.162	E9600	C43419	5140.162	—	5240.3
—	1700.0	54/7	1.502	E33719	7640.162	E9600	C43419	5140.162	—	5240.3
—	2303.5	54/37	1.750	E33720	7648.184	E9800	—	5148.184	—	5244.3
—	2303.5	63/28	1.750	E33720	7648.184	E9800	—	5148.184	—	5244.3
—	2338.0	42/19	1.762	E33720	7648.184	E9800	—	5148.184	—	5244.3

Quick Reference Guide for Standard Compression Accessories for EHS ACSR, Steel Ground Wire, Alumoweld® and AWAC

Code Word	Conductor Size			Compression Accessories								
	AWG or kcmil	Stranding		Aluminum Dead End Single Tongue	Steel Component		15° Terminal Connector	Compression Joint		Jumper Connector	Straight Terminal Connector	90° Terminal Connector
		Al	Steel		Eye	Clevis		Al	Steel			
EHS ACSR												
Petrel	101.8	12	7	8320.500	9110.295	—	5174.484	8420.500	4010.295	—	—	—
Minorca	110.8	12	7	8320.531	9110.302	—	5174.500	8420.531	4010.302	—	—	—
Leghorn	134.6	12	7	8324.562	9112.332	—	5175.547	8424.562	4012.332	—	—	—
Guinea	159	12	7	8324.625	9112.377	—	5175.609	8424.625	4012.377	—	—	—
Dotteral	176.9	12	7	8324.656	9112.386	—	5176.656	8424.656	4012.386	—	—	—
Dorking	190.8	12	7	8324.688	9214.406	—	5176.688	8424.688	4014.406	—	—	—
Brahma	203.2	16	19	8330.750	9316.516	—	5176.750	8430.750	4016.516	—	—	—
Cochin	211.3	12	7	8324.719	9214.422	—	5176.719	8424.719	4014.422	—	—	—
STEEL GROUND WIRE												
—	5/16 GW	—	—	—	—	—	5173.357	4912.332	—	5073.357	5673.357	5873.357
—	3/8 GW	—	—	—	—	See Page 19	5173.391	4914.386	—	5074.438	5673.391	5873.391
—	7/16 GW	—	—	—	—	—	5175.547	4916.453	—	5075.547	5675.547	5875.547
—	1/2 GW	—	—	—	—	—	5175.547	4918.531	—	5075.547	5675.547	5875.547
ALUMOWELD STRAND												
—	3 NO 10	—	—	—	—	—	5172.281	4910.251	—	5072.281	5672.281	5872.281
—	3 NO 9	—	—	—	—	—	5172.281	4910.281	—	5072.281	5672.281	5872.281
—	3 NO 8	—	—	—	—	—	5106.312	4910.295	—	5072.312	5606.312	5806.312
—	3 NO 7	—	—	—	—	—	5109.344	4910.324	—	5009.344	5609.344	5809.344
—	3 NO 6	—	—	—	—	—	5109.375	4912.351	—	5009.375	5609.375	5809.375
—	3 NO 5	—	—	—	—	—	5174.438	4914.406	—	5074.438	5674.438	5874.438
—	7 NO 10	—	—	—	—	See Page 19	5106.344	4912.330	—	5009.344	5606.344	5806.344
—	7 NO 9	—	—	—	—	—	5173.391	4912.359	—	5073.391	5673.391	5873.391
—	7 NO 8	—	—	—	—	—	5174.438	4914.406	—	5074.438	5674.438	5874.438
—	7 NO 7	—	—	—	—	—	5174.484	4916.484	—	5074.484	5674.484	5874.484
—	7 NO 6	—	—	—	—	—	5175.547	4916.531	—	5075.547	5675.547	5875.547
—	7 NO 5	—	—	—	—	—	5175.609	4918.594	—	5075.609	5675.609	5875.609
—	19 NO 10	—	—	—	—	—	5175.547	4918.530	—	—	—	—
—	19 NO 9	—	—	—	—	—	5176.656	4920.625	—	5076.656	5676.656	5876.656
AWAC												
—	4	6	1	—	—	—	—	7506.298	—	—	—	—
—	4	5	2	—	—	—	—	8508.312	—	—	—	—
—	4	4	3	—	—	—	—	8510.344	—	—	—	—
—	2	6	1	—	—	—	—	7509.375	—	—	—	—
—	2	5	2	—	—	—	—	8510.344	—	—	—	—
—	2	4	3	—	—	—	—	8511.438	—	—	—	—
—	1/0	6	1	8611.453	—	A100X	5111.453	7511.453	—	—	5611.453	5811.453
—	1/0	5	2	8612.516	—	A100X	5112.516	8512.516	—	—	5612.516	5812.516
—	1/0	4	3	8613.531	—	A102X	5113.531	8513.531	—	—	5613.531	5813.531
—	2/0	6	1	8612.484	—	A100X	5124.484	7512.484	—	—	5612.484	5812.484
—	2/0	5	2	8613.542	—	A102X	5113.542	8513.542	—	—	5613.542	5813.542
—	2/0	4	3	8676.594	—	A102X	5176.594	8576.594	—	—	5676.594	5876.594
—	4/0	6	1	8613.625	—	A102X	5113.625	7513.625	—	—	5613.625	5813.625
—	4/0	15	4	8676.656	—	A102X	5176.656	8576.656	—	—	5676.656	5876.656
—	336.4	18	1	8676.719	—	A101X	5176.719	8576.719	—	—	5676.719	5876.719

Standard Compression Catalog Numbering System

TYPE OF ACCESSORY	DIE SIZE	BORE CODE
80	44	184

The simplified AFL catalog numbering system for compression accessories facilitates specifying, ordering and inventory control. The catalog number is stamped on each compression accessory for easy and positive field identification.

Example: Catalog No. 8130.116

The catalog number shown (8130.116) is an ACSR dead end body with a single tongue (81), requiring a size 30AH compressor die (30) and for a conductor size which utilizes the given bore code (116).

Type of Accessory

Steel Ground Wire or Alumoweld

- 45 Dead End
- 49 Joint

All Conductor Types (except Steel Ground Wire and Alumoweld)

- 52 Repair Sleeve

All Conductor Types

- 50 Jumper (Loop) Connector
- 51 15° Terminal Connector
- 53 Tee Tap (cable/flat) Open Run
- 55 Tee Connector (cable/cable) Open Run
- 56 Straight Terminal Connector
- 58 90° Terminal Connector

AAC Conductors

- 70 Joint
- 71 Dead End Body (single tongue)
- 72 Dead End Body (double tongue)

ACAR and ACAR Alloy Conductors

- 75 Joint
- 76 Dead End Body (single tongue)
- 77 Dead End Body (double tongue)

ACSR Conductors

- 80 Joint
- 81 Dead End Body (single tongue)
- 82 Dead End Body (double tongue)

EHS ACSR Conductors

- 83 Dead End Body (single tongue)
- 84 Joint

AWAC Conductors

- 85 Joint
- 86 Dead End Body (single tongue)

Single Components

- 40 Steel Sleeve
- C61-C68 Adjustable Clevis Dead Ends
- 90-94 and
- E95-E98 Eye Dead Ends
- 100-103 and
- A100X-A103X ... Clevis Dead Ends

Compression Dead Ends—33100 Series for ACSR Conductor, Eye or Clevis Type, Single Tongue

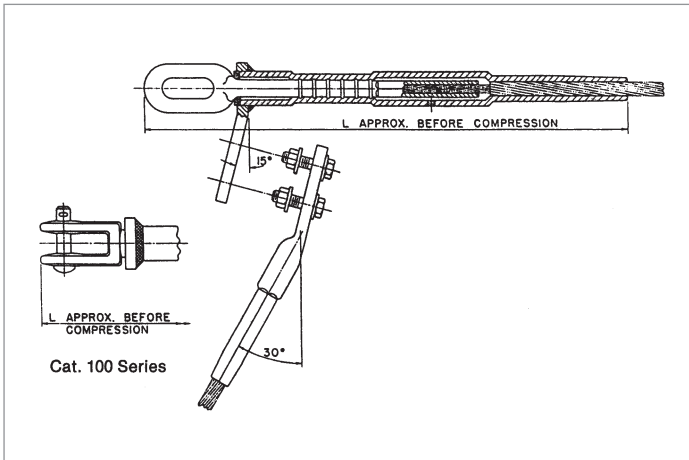

The 33100 Series Dead End Assembly is specifically designed for ACSR conductors. The aluminum body of the dead end is fabricated from AFL seamless drawn aluminum. The tongue and terminal pad are constructed with a 15° angle, which permits the terminal connector to be bolted in the straight or 30° position.

All dead ends are designed for full tension use, achieving a minimum of 95% of the ASTM rated strength of the conductor on which they are used. Each dead end assembly comes with a dead end body, steel eye or clevis, 15° terminal and aluminum hardware.

For die size sections 30AH and above, the end tapers of the compression portions of all compression accessories are supplied with a high voltage finish. Corona bolts are furnished as standard on 15° terminals for these section sizes.

The square edges of bolted pads on compression accessories could cause Corona in environments greater than or equal to 345 kV. Pads with edges and corners rounded can be supplied by adding the catalog suffix "EHV".

Ordering Instructions

Step 1: Assembly Catalog Number

Determine the assembly catalog number based on the conductor being used.

Step 2: Terminal Connector

For an assembly without a terminal connector, use 'NT'. For an assembly with a terminal connector, leave blank.

Step 3: Extra High Voltage Finish

For Extra High Voltage Finish, use 'EHV'. For Standard Finish, leave blank.

Step 4: Assemble Catalog Number.



Example:

For 795 Drake conductor with no terminal and EHV finish, the complete catalog number is:

E33142NTEHV

Notes:

1. Eye and Clevis Dimensions are on page 119.
2. Pad Dimensions are on page 117.
3. AFL Filler Compound (AFC) Requirements are on page 115.
4. Installation Instructions for Dead Ends are on page 127.
5. Installation Instructions for Terminals are on page 131.

Compression Dead Ends—33100 Series for ACSR Conductor, Eye or Clevis Type, Single Tongue (cont.)

DEAD END ASSEMBLY CATALOG NUMBER	CONDUCTOR				ALUMINUM BODY SINGLE TONGUE	STEEL COMPONENT		15° TERMINAL CONNECTOR	DIE SIZE		TOTAL WEIGHT		DIMENSION L		PAD SIZE
	CODE WORD	SIZE	STRANDING	DIA.		STEEL EYE	STEEL CLEVIS		ALUMINUM HEX DIES	STEEL HEX DIES	LBS	KG	IN	MM	
		KCMIL	AL/ST	IN											
C33102	Raven	1/0	6/1	0.398	8174.438	—	100.14	5174.438	74AH	74SH	2.3	1.06	14.4	365	B
C33103	Quail	2/0	6/1	0.447	8174.484	—	100.16	5174.484	74AH	74SH	2.0	0.92	14.4	365	B
C33104	Pigeon	3/0	6/1	0.502	8175.547	—	102.17	5175.547	75AH	75SH	3.9	1.74	17.3	438	B
C33105	Penguin	4/0	6/1	0.563	8175.609	—	102.20	5175.609	75AH	75SH	3.6	1.64	17.3	438	B
C33106	Waxwing	266.8	18/1	0.609	8176.656	—	101.13	5176.656	76AH	74SH	4.2	1.91	18.4	467	B
C33107	Owl	266.8	6/7	0.633	8176.688	—	103.22	5176.688	76AH	76SH	4.1	1.85	18.1	460	B
C33108	Partridge	266.8	26/7	0.642	8176.688	—	103.25	5176.688	76AH	76SH	4.1	1.85	18.1	460	B
C33109	Ostrich	300.0	26/7	0.680	8176.719	—	103.26	5176.719	76AH	76SH	4.0	1.80	18.1	460	B
C33110	Merlin	336.4	18/1	0.684	8176.719	—	101.14	5176.719	76AH	74SH	3.9	1.76	18.1	460	B
C33111	Linnet	336.4	26/7	0.721	8176.781	—	103.28	5176.781	76AH	76SH	3.7	1.68	18.1	460	B
C33112	Chickadee	397.5	18/1	0.743	8176.781	—	101.16	5176.781	76AH	74SH	3.6	1.64	18.1	460	B
E33113	Linnet	336.4	26/7	0.721	8120.781	9110.277	—	5120.781	20AH	10SH	4.8	2.18	23.3	592	B
E33114	Oriole	336.4	30/7	0.741	8120.781	9110.332	—	5120.781	20AH	10SH	4.8	2.18	23.3	592	B
E33115	Chickadee	397.5	18/1	0.743	8120.781	9174.160	—	5120.781	20AH	74SH	4.6	2.09	23.3	592	B
E33116	Brant	397.5	24/7	0.772	8120.812	9110.261	—	5120.812	20AH	10SH	4.5	2.05	22.6	575	B
E33117	Ibis	397.5	26/7	0.783	8120.844	9110.302	—	5120.844	20AH	10SH	4.4	1.99	22.6	575	B
E33118	Lark	397.5	30/7	0.806	8120.844	9112.359	—	5120.844	20AH	12SH	4.5	2.03	22.6	575	B
E33119	Pelican	477.0	18/1	0.814	8124.875	9175.179	—	5124.875	24AH	75SH	5.6	2.55	21.6	548	B
E33120	Flicker	477.0	24/7	0.846	8124.938	9110.295	—	5124.938	24AH	10SH	5.8	2.64	22.7	576	B
E33121	Hawk	477.0	26/7	0.858	8124.938	9112.332	—	5124.938	24AH	12SH	5.9	2.68	22.7	576	B
E33122	Hen	477.0	30/7	0.883	8124.938C	9212.397	—	5124.938	24AH	12SH	5.9	2.68	22.8	579	B
E33123	Osprey	556.5	18/1	0.879	8124.938C	9275.188	—	5124.938	24AH	75SH	6.4	2.90	22.8	579	B
E33124	Parakeet	556.5	24/7	0.914	8124.969	9210.316	—	5124.969	24AH	10SH	6.4	2.90	23.3	592	B
E33125	Dove	556.5	26/7	0.927	8124.969	9212.359	—	5124.969	24AH	12SH	6.4	2.90	23.3	592	B
E33126	Eagle	556.5	30/7	0.953	8127.100	9314.432	—	5127.100	27AH	14SH	9.0	4.08	25.0	635	D
E33127	Peacock	605.0	24/7	0.953	8127.100	9212.332	—	5127.100	27AH	12SH	8.0	3.63	24.8	630	D
E33128	Squab	605.0	26/7	0.966	8127.100	9212.377	—	5127.100	27AH	12SH	8.0	3.63	24.8	630	D
E33129	Teal	605.0	30/19	0.994	8127.106	9314.441	—	5127.106	27AH	14SH	8.9	4.03	25.0	635	D
E33130	Swift	636.0	36/1	0.930	8127.100	9274.148	—	5127.100	27AH	74SH	7.7	3.49	24.8	630	D
E33131	Kingbird	636.0	18/1	0.940	8127.100	9275.203	—	5127.100	27AH	75SH	7.7	3.49	24.8	630	D
E33132	Rook	636.0	24/7	0.977	8127.106	9212.344	—	5127.106	27AH	12SH	7.9	3.58	24.8	630	D
E33133	Grosbeak	636.0	26/7	0.990	8127.106	9212.386	—	5127.106	27AH	12SH	7.9	3.58	24.8	630	D
E33134	Egret	636.0	30/19	1.019	8127.106	9314.453	—	5127.106	27AH	14SH	8.9	4.03	25.0	635	D
E33135	Flamingo	666.6	24/7	1.000	8127.106	9212.351	—	5127.106	27AH	12SH	7.9	3.58	24.8	630	D
E33136	Stilt	715.5	24/7	1.036	8130.109	9312.359	—	5130.109	30AH	12SH	10.5	4.76	25.4	645	D
E33137	Starling	715.5	26/7	1.051	8130.109	9314.406	—	5130.109	30AH	14SH	10.7	4.85	25.4	645	D
E33138	Redwing	715.5	30/19	1.081	8130.116	9316.500	—	5130.116	30AH	16SH	10.5	4.76	25.9	657	D
E33139	Coot	795.0	36/1	1.040	8130.109	9374.160	—	5130.109	30AH	74SH	10.2	4.54	25.4	645	D
E33140	Tern	795.0	45/7	1.063	8130.116	9310.277	—	5130.116	30AH	10SH	10.1	4.58	25.9	657	D
E33141	Condor	795.0	54/7	1.093	8130.116	9312.386	—	5130.116	30AH	12SH	10.3	4.67	25.9	657	D
E33142	Drake	795.0	26/7	1.108	8130.116	9314.432	—	5130.116	30AH	14SH	10.5	4.76	25.9	657	D
E33143	Mallard	795.0	30/19	1.140	8130.122	9416.516	—	5130.122	30AH	16SH	10.8	4.89	26.5	673	D
E33141	Cuckoo	795.0	24/7	1.092	8130.116	9312.386	—	5130.116	30AH	12SH	10.3	4.67	25.9	657	D
E33145	Ruddy	900.0	45/7	1.131	8130.122	9310.302	—	5130.122	30AH	10SH	10.0	4.53	26.4	683	D

Compression Dead Ends—33100 Series for ACSR Conductor, Eye or Clevis Type, Single Tongue (cont.)

DEAD END ASSEMBLY CATALOG NUMBER	CONDUCTOR				ALUMINUM BODY SINGLE TONGUE	STEEL COMPONENT		15° TERMINAL CONNECTOR	DIE SIZE		TOTAL WEIGHT		DIMENSION L		PAD SIZE
	CODE WORD	SIZE	STRANDING	DIA.		STEEL EYE	STEEL CLEVIS		ALUMINUM HEX DIES	STEEL HEX DIES	LBS	KG	IN	MM	
		KCMIL	AL/ST	IN											
E33146	Canary	900.0	54/7	1.162	8130.122	9414.406	—	5130.122	30AH	14SH	10.8	4.89	26.5	673	D
E33147	Catbird	954.0	36/1	1.140	8130.122	9475.179	—	5130.122	30AH	75SH	10.4	4.71	26.5	673	D
E33148	Rail	954.0	45/7	1.165	8130.122	9410.302	—	5130.122	30AH	10SH	10.4	4.71	26.5	673	D
E33150	Cardinal	954.0	54/7	1.196	8130.125	9414.422	—	5130.125	30AH	14SH	10.8	4.89	27.3	692	D
E33151	Tanager	1033.5	36/1	1.186	8130.125	9475.184	—	5130.125	30AH	75SH	10.4	4.71	27.3	692	D
E33152	Ortolan	1033.5	45/7	1.212	8134.128	9410.316	—	5134.128	34AH	10SH	13.3	6.03	27.5	699	D
E33154	Curlew	1033.5	54/7	1.244	8134.134	9414.432	—	5134.134	34AH	14SH	13.1	5.94	28.1	714	D
E33155	Bluejay	1113.0	45/7	1.259	8134.134	9412.332	—	5134.134	34AH	12SH	12.8	5.81	28.1	714	D
E33158	Bunting	1192.5	45/7	1.302	8134.138	E9512.344	—	5134.138	34AH	12SH	12.9	5.85	28.2	716	D
E33161	Bittern	1272.0	45/7	1.345	8136.144	E9512.351	—	5136.144	36AH	12SH	14.2	6.43	28.3	719	D
E33163	Pheasant	1272.0	54/19	1.382	8136.147	E9616.500	—	5136.147	36AH	16SH	14.9	6.75	28.6	725	D
E33164	Dipper	1351.5	45/7	1.385	8136.147	E9612.377	—	5136.147	36AH	12SH	14.4	6.53	28.6	725	D
E33166	Martin	1351.5	54/19	1.424	8138.150	E9616.500	—	5138.150	38AH	16SH	16.8	7.62	28.8	732	D
E33167	Bobolink	1431.0	45/7	1.427	8138.150	E9612.377	—	5138.150	38AH	12SH	16.3	7.40	28.8	732	D
E33169	Plover	1431.0	54/19	1.465	8138.156	E9616.516	—	5138.156	38AH	16SH	16.4	7.44	28.8	732	D
E33170	Nuthatch	1510.5	45/7	1.466	8138.156	E9612.386	—	5138.156	38AH	12SH	15.9	7.22	28.8	732	D
E33172	Parrot	1510.5	54/19	1.506	8140.162	E9616.531	—	5140.162	40AH	16SH	19.6	8.88	29.7	754	E
E33173	Lapwing	1590.0	45/7	1.504	8140.162	E9612.397	—	5140.162	40AH	12SH	19.1	8.66	29.7	759	E
E33174	Falcon	1590.0	54/19	1.545	8140.162	E9718.546	—	5140.162	40AH	18SH	20.8	9.43	29.8	757	E
E33175	Chukar	1780.0	84/19	1.602	8142.178	E9714.453	—	5142.178	42AH	14SH	21.1	9.57	31.0	787	E
E33177	—	2034.0	72/7	1.681	8142.178C	E9814.359	—	5142.176	42AH	14SH	22.6	10.26	31.3	795	E
E33178	Bluebird	2156.0	84/19	1.762	8144.184	E9816.516	—	5144.184	44AH	16SH	23.0	10.43	28.9	734	E
E33179	Kiwi	2167.0	72/7	1.737	8144.181	E9812.377	—	5144.181	44AH	12SH	23.5	10.65	30.9	784	E
E33181	Thrasher	2312.0	76/19	1.802	8144.188	E9814.422	—	5144.188	44AH	14SH	23.1	10.47	30.9	784	E
E33182	Joree	2515.0	76/19	1.880	8148.197	E9814.453	—	5148.197	48AH	14SH	29.2	13.25	33.3	846	E

Compression Dead Ends—33300 Series for ACSR Conductor, Eye or Clevis Type, Double Tongue

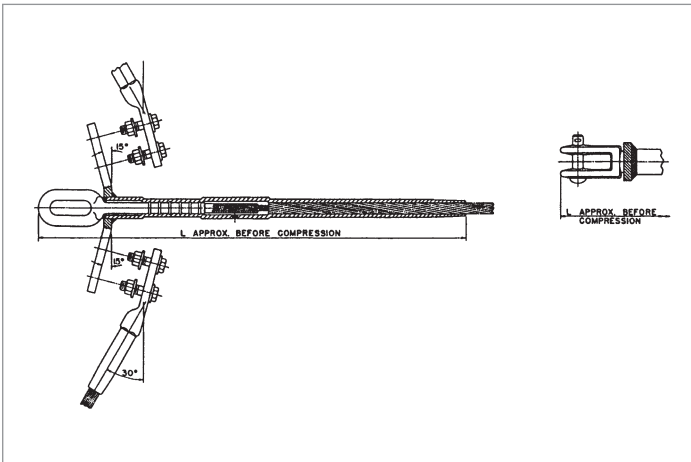

The 33300 Series Double Tongue Dead End Assembly is specifically designed for ACSR conductors. The aluminum body of the dead end is fabricated from AFL seamless drawn aluminum. The tongue and terminal pad are constructed with a 15° angle, which permits the terminal connector to be bolted in the straight or 30° position.

All dead ends are designed for full tension use, achieving a minimum of 95% of the ASTM rated strength of the conductor on which they are used. Each dead end assembly comes with a dead end body, steel eye or clevis, two 15° terminals and aluminum hardware.

For die size sections 30AH and above, the end tapers of the compression portions of all compression accessories are supplied with a high voltage finish. Corona bolts are furnished as standard on 15° terminals for these section sizes.

The square edges of bolted pads on compression accessories could cause Corona in environments greater than or equal to 345 kV. Pads with edges and corners rounded can be supplied by adding the catalog suffix "EHV".

Ordering Instructions

Step 1: Assembly Catalog Number

Determine the assembly catalog number based on the conductor being used.

Step 2: Terminal Connector

For an assembly without a terminal connector, use 'NT'.
For an assembly with a terminal connector, leave blank.

Step 3: Extra High Voltage Finish

For Extra High Voltage Finish, use 'EHV'.
For Standard Finish, leave blank.

Step 4: Assemble Catalog Number.



Example:

For 795 Drake Conductor with no terminal and EHV finish, the complete catalog number is:

E33342NTEHV

Notes:

1. Eye and Clevis Dimensions are on page 119.
2. Pad Dimensions are on page 117.
3. AFL Filler Compound (AFC) Requirements are on page 115.
4. Installation Instructions for Dead Ends are on page 127.
5. Installation Instructions for Terminals are on page 131.

Compression Dead Ends—33300 Series for ACSR Conductor, Eye or Clevis Type, Double Tongue (cont.)

DEAD END ASSEMBLY CATALOG NUMBER	CONDUCTOR				ALUMINUM BODY DOUBLE TONGUE	STEEL COMPONENT		15° TERMINAL CONNECTOR	DIE SIZE		TOTAL WEIGHT		DIMENSION L		PAD SIZE
	CODE WORD	SIZE	STRANDING	DIA.		STEEL EYE	STEEL CLEVIS		ALUMINUM HEX DIES	STEEL HEX DIES	LBS	KG	IN	MM	
		KCMIL	AL/ST	IN											
C33301	Grouse	80.0	8/1	0.367	8274.438S	—	102.17	5174.438	74AH	75SH	3.8	1.74	16.1	409	B
C33302	Raven	1/0	6/1	0.398	8274.438	—	100.14	5174.438	74AH	74SH	3.0	1.38	14.4	365	B
C33303	Quail	2/0	6/1	0.447	8274.484	—	100.16	5174.484	74AH	74SH	2.7	1.23	14.4	365	B
C33304	Pigeon	3/0	6/1	0.502	8275.547	—	102.17	5175.547	75AH	75SH	4.3	1.92	17.3	438	B
C33305	Penguin	4/0	6/1	0.563	8275.609	—	102.2	5175.609	75AH	75SH	4.0	1.82	17.3	438	B
C33306	Waxwing	266.8	18/1	0.609	8276.656	—	101.13	5176.656	76AH	74SH	4.6	2.09	18.4	467	B
C33307	Owl	266.8	6/7	0.633	8276.688	—	103.22	5176.688	76AH	76SH	4.5	2.03	18.1	460	B
C33308	Partridge	266.8	26/7	0.642	8276.688	—	103.25	5176.688	76AH	76SH	4.5	2.03	18.1	460	B
C33309	Ostrich	300.0	26/7	0.680	8276.719	—	103.26	5176.719	76AH	76SH	4.4	1.98	18.1	460	B
C33310	Merlin	336.4	18/1	0.684	8276.719	—	101.14	5176.719	76AH	74SH	4.3	1.94	18.1	460	B
C33311	Linnet	336.4	26/7	0.721	8276.781	—	103.28	5176.781	76AH	76SH	4.1	1.87	18.1	460	B
C33312	Chickadee	397.5	18/1	0.743	8276.781	—	101.16	5176.781	76AH	74SH	4.0	1.83	18.1	460	B
E33313	Linnet	336.4	26/7	0.721	8220.781	9110.277	—	5120.781	20AH	10SH	5.3	2.40	23.3	592	B
E33314	Oriole	336.4	30/7	0.741	8220.781	9110.332	—	5120.781	20AH	10SH	5.3	2.40	23.3	592	B
E33315	Chickadee	397.5	18/1	0.743	8220.781	9174.160	—	5120.781	20AH	74SH	5.1	2.31	23.3	592	B
E33316	Brant	397.5	24/7	0.772	8220.812	9110.261	—	5120.812	20AH	10SH	5.0	2.26	22.6	575	B
E33317	Ibis	397.5	26/7	0.783	8220.844	9110.302	—	5120.844	20AH	10SH	4.9	2.21	22.6	575	B
E33318	Lark	397.5	30/7	0.806	8220.844	9112.359	—	5120.844	20AH	12SH	5.0	2.25	22.6	575	B
E33319	Pelican	477.0	18/1	0.814	8224.875	9175.179	—	5124.875	24AH	75SH	6.1	2.77	21.6	548	B
E33320	Flicker	477.0	24/7	0.846	8224.938	9110.295	—	5124.938	24AH	10SH	6.2	2.82	22.7	576	B
E33321	Hawk	477.0	26/7	0.858	8224.938	9112.332	—	5124.938	24AH	12SH	6.3	2.86	22.7	576	B
E33322	Hen	477.0	30/7	0.883	8224.938C	9212.397	—	5124.938	24AH	12SH	6.8	3.09	22.8	579	B
E33323	Osprey	556.5	18/1	0.879	8224.938C	9275.188	—	5124.938	24AH	75SH	6.5	2.95	22.8	579	B
E33324	Parakeet	556.5	24/7	0.914	8224.969	9210.316	—	5124.969	24AH	10SH	6.6	2.99	23.3	592	B
E33325	Dove	556.5	26/7	0.927	8224.969	9212.359	—	5124.969	24AH	12SH	6.9	3.13	23.3	592	B
E33326	Eagle	556.5	30/7	0.953	8227.100	9314.432	—	5127.100	27AH	14SH	9.8	4.44	25.0	635	D
E33327	Peacock	605.0	24/7	0.953	8227.100	9212.332	—	5127.100	27AH	12SH	8.8	3.99	24.8	630	D
E33328	Squab	605.0	26/7	0.966	8227.100	9212.377	—	5127.100	27AH	12SH	8.8	3.99	24.8	630	D
E33329	Teal	605.0	30/19	0.994	8227.106	9314.441	—	5127.106	27AH	14SH	9.7	4.40	25.0	635	D
E33330	Swift	636.0	36/1	0.930	8227.100	9274.148	—	5127.100	27AH	74SH	8.5	3.85	24.8	630	D
E33331	Kingbird	636.0	18/1	0.940	8227.100	9275.203	—	5127.100	27AH	75SH	8.5	3.85	24.8	630	D
E33332	Rook	636.0	24/7	0.977	8227.106	9212.344	—	5127.106	27AH	12SH	8.7	3.95	24.8	630	D
E33333	Grosbeak	636.0	26/7	0.990	8227.106	9212.386	—	5127.106	27AH	12SH	8.7	3.95	24.8	630	D
E33334	Egret	636.0	30/19	1.019	8227.106	9314.453	—	5127.106	27AH	14SH	9.7	4.40	25.0	635	D
E33335	Flamingo	666.6	24/7	1.000	8227.106	9212.351	—	5127.106	27AH	12SH	8.7	3.95	24.8	630	D
E33336	Stilt	715.5	24/7	1.036	8230.109	9312.359	—	5130.109	30AH	12SH	11.4	5.17	25.4	645	D
E33337	Starling	715.5	26/7	1.051	8230.109	9314.406	—	5130.109	30AH	14SH	11.6	5.26	25.4	645	D
E33338	Redwing	715.5	30/19	1.081	8230.116	9316.500	—	5130.116	30AH	16SH	11.4	5.17	25.9	657	D
E33339	Coot	795.0	36/1	1.040	8230.109	9374.160	—	5130.109	30AH	74SH	11.1	5.03	25.4	645	D
E33340	Tern	795.0	45/7	1.063	8230.116	9310.277	—	5130.116	30AH	10SH	11.0	4.99	25.9	657	D
E33341	Condor	795.0	54/7	1.093	8230.116	9312.386	—	5130.116	30AH	12SH	11.2	5.08	25.9	657	D
E33342	Drake	795.0	26/7	1.108	8230.116	9314.432	—	5130.116	30AH	14SH	11.4	5.17	25.9	658	D

Compression Dead Ends—33300 Series for ACSR Conductor, Eye or Clevis Type, Double Tongue (cont.)

DEAD END ASSEMBLY CATALOG NUMBER	CONDUCTOR				ALUMINUM BODY DOUBLE TONGUE	STEEL COMPONENT		15° TERMINAL CONNECTOR	DIE SIZE		TOTAL WEIGHT		DIMENSION L		PAD SIZE
	CODE WORD	SIZE	STRANDING	DIA.		STEEL EYE	STEEL CLEVIS		ALUMINUM HEX DIES	STEEL HEX DIES	LBS	KG	IN	MM	
		KCMIL	AL/ST	IN											
E33343	Mallard	795.0	30/19	1.140	8230.122	9416.516	—	5130.122	30AH	16SH	11.7	5.30	26.5	673	D
E33341	Cuckoo	795.0	24/7	1.092	8230.116	9312.386	—	5130.116	30AH	12SH	11.2	5.08	25.9	657	D
E33345	Ruddy	900.0	45/7	1.131	8230.122	9310.302	—	5130.122	30AH	10SH	10.9	4.94	26.4	683	D
E33346	Canary	900.0	54/7	1.162	8230.122	9414.406	—	5130.122	30AH	14SH	11.7	5.30	26.5	673	D
E33347	Catbird	954.0	36/1	1.140	8230.122	9475.179	—	5130.122	30AH	75SH	11.5	5.12	26.5	673	D
E33348	Rail	954.0	45/7	1.165	8230.122	9410.302	—	5130.122	30AH	10SH	11.3	5.12	26.5	673	D
E33350	Cardinal	954.0	54/7	1.196	8230.125	9414.422	—	5130.125	30AH	14SH	11.7	5.30	27.3	692	D
E33351	Tanager	1033.5	36/1	1.186	8230.125	9475.184	—	5130.125	30AH	75SH	11.3	5.12	27.3	692	D
E33352	Ortolan	1033.5	45/7	1.212	8234.128	9410.316	—	5134.128	34AH	10SH	14.1	6.39	27.5	699	D
E33354	Curlew	1033.5	54/7	1.244	8234.134	9414.432	—	5134.134	34AH	14SH	13.9	6.30	28.1	714	D
E33355	Bluejay	1113.0	45/7	1.259	8234.134	9412.332	—	5134.134	34AH	12SH	13.6	6.17	28.1	714	D
E33358	Bunting	1192.5	45/7	1.302	8234.138	E9512.344	—	5134.138	34AH	12SH	13.7	6.21	28.2	716	D
E33361	Bittern	1272.0	45/7	1.345	8236.144	E9512.351	—	5136.144	36AH	12SH	15.0	6.80	28.3	719	D
E33363	Pheasant	1272.0	54/19	1.382	8236.147	E9616.500	—	5136.147	36AH	16SH	15.7	7.12	28.6	725	D
E33364	Dipper	1351.5	45/7	1.385	8236.147	E9612.377	—	5136.147	36AH	12SH	15.2	6.90	28.6	725	D
E33366	Martin	1351.5	54/19	1.424	8238.150	E9616.500	—	5138.150	38AH	16SH	17.7	8.02	28.8	732	D
E33367	Bobolink	1431.0	45/7	1.427	8238.150	E9612.377	—	5138.150	38AH	12SH	15.2	7.80	28.8	732	D
E33369	Plover	1431.0	54/19	1.465	8238.156	E9616.516	—	5138.156	38AH	16SH	17.3	7.85	28.8	732	E
E33370	Nuthatch	1510.5	45/7	1.466	8238.156	E9612.386	—	5138.156	38AH	12SH	16.8	7.63	28.8	732	E
E33372	Parrot	1510.5	54/19	1.506	8240.162	E9616.531	—	5140.162	40AH	16SH	21.4	9.70	29.7	754	E
E33373	Lapwing	1590.0	45/7	1.504	8240.162	E9612.397	—	5140.162	40AH	12SH	20.9	9.48	29.7	759	E
E33374	Falcon	1590.0	54/19	1.545	8240.162	E9718.546	—	5140.162	40AH	18SH	22.6	10.25	29.8	757	E
E33375	Chukar	1780.0	84/19	1.602	8242.178	E9714.453	—	5142.178	42AH	14SH	21.6	9.80	31.0	787	E
E33377	—	2034.0	72/7	1.681	8242.178C	E9814.359	—	5142.178	42AH	14SH	23.1	10.48	31.3	795	E
E33378	Bluebird	2156.0	84/19	1.762	8244.184	E9816.516	—	5144.184	44AH	16SH	23.4	10.61	28.9	734	E
E33379	Kiwi	2167.0	72/7	1.737	8244.181	E9812.377	—	5144.181	44AH	12SH	23.9	10.83	30.9	784	E
E33381	Thrasher	2312.0	76/19	1.802	8244.188	E9814.422	—	5144.188	44AH	14SH	23.5	10.66	30.9	784	E
E33382	Joree	2515.0	76/19	1.880	8248.197	E9814.453	—	5148.197	48AH	14SH	30.5	13.84	33.3	846	E

Compression Dead Ends—43600 Series for ACSR Conductor, Adjustable Clevis Type, Single Tongue

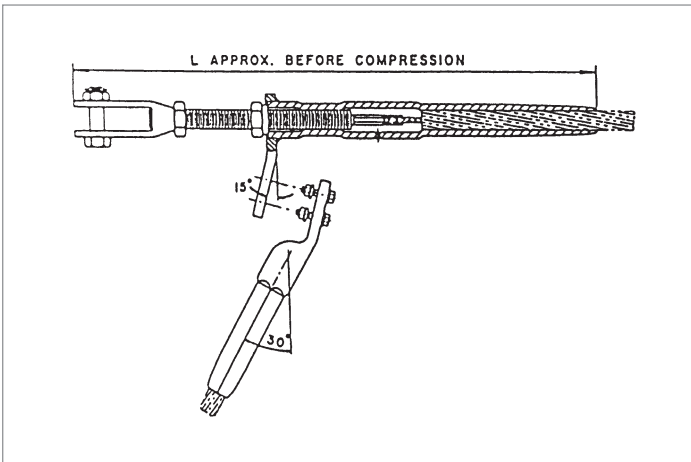

The 43600 Series Adjustable Clevis Dead End Assembly is specifically designed for ACSR conductors. The aluminum body of the dead end is fabricated from AFL seamless drawn aluminum. The tongue and terminal pad are constructed with a 15° angle, which permits the terminal connector to be bolted in the straight or 30° position.

All dead ends are designed for full tension use, achieving a minimum of 95% of the ASTM rated strength of the conductor on which they are used. Each dead end assembly comes with a dead end body, adjustable steel clevis, 15° terminal and aluminum hardware.

For die size sections 30AH and above, the end tapers of the compression portions of all compression accessories are supplied with a high voltage finish. Corona bolts are furnished as standard on 15° terminals for these section sizes.

The square edges of bolted pads on compression accessories could cause Corona in environments greater than or equal to 345 kV. Pads with edges and corners rounded can be supplied by adding the catalog suffix "EHV".

Ordering Instructions

Step 1: Assembly Catalog Number

Determine the assembly catalog number based on the conductor being used.

Step 2: Terminal Connector

For an assembly without a terminal connector, use 'NT'.
For an assembly with a terminal connector, leave blank.

Step 3: Extra High Voltage Finish

For Extra High Voltage Finish, use 'EHV'.
For Standard Finish, leave blank.

Step 4: Assemble Catalog Number.



Example:

For 795 Drake conductor with no terminal and EHV finish, the complete catalog number is:

C43642NTEHV

Notes:

1. Adjustable Clevis Dimensions are on page 120.
2. Pad Dimensions are on page 117.
3. AFL Filler Compound (AFC) Requirements are on page 115.
4. Installation Instructions for Dead Ends are on page 129.
5. Installation Instructions for Terminals are on page 131.

Compression Dead Ends—43600 Series for ACSR Conductor, Adjustable Clevis Type, Single Tongue (cont.)

DEAD END ASSEMBLY CATALOG NUMBER	CODE WORD	CONDUCTOR			ALUMINUM BODY SINGLE TONGUE	ADJUSTABLE STEEL CLEVIS	15° TERMINAL CONNECTOR	DIE SIZE		DIMENSION L		PAD SIZE
		SIZE	STRANDING	DIA.				ALUMINUM HEX DIES	STEEL HEX DIES	IN	MM	
		KCMIL	AL/ST	IN								
C43613	Linnet	336.4	26/7	0.721	8120.781	C6110.277	5120.781	20AH	10SH			
C43614	Oriole	336.4	30/7	0.741	8120.781	C6110.332	5120.781	20AH	10SH			
C43615	Chickadee	397.5	18/1	0.743	8120.781	C6174.160	5120.781	20AH	74SH			
C43616	Brant	397.5	24/7	0.772	8120.812	C6110.261	5120.812	20AH	10SH			
C43617	Ibis	397.5	26/7	0.783	8120.844	C6110.302	5120.844	20AH	10SH			
C43618	Lark	397.5	30/7	0.806	8120.844	C6112.359	5120.844	20AH	12SH			
C43619	Pelican	477.0	18/1	0.814	8124.875	C6175.179	5124.875	24AH	75SH			
C43620	Flicker	477.0	24/7	0.846	8124.938C	C6210.295	5124.938	24AH	10SH			
C43621	Hawk	477.0	26/7	0.858	8124.938C	C6212.332	5124.938	24AH	12SH			
C43622	Hen	477.0	30/7	0.883	8124.938C	C6212.397	5124.938	24AH	12SH			
C43623	Osprey	556.5	18/1	0.879	8124.938C	C6275.188	5124.938	24AH	75SH			
C43624	Parakeet	556.5	24/7	0.914	8124.969C	C6210.316	5124.969	24AH	10SH			
C43625	Dove	556.5	26/7	0.927	8124.969C	C6212.359	5124.969	24AH	12SH			
C43626	Eagle	556.5	30/7	0.953	8127.100	C6214.432	5127.100	27AH	14SH			
C43627	Peacock	605.0	24/7	0.953	8127.100	C6212.332	5127.100	27AH	12SH			
C43628	Squab	605.0	26/7	0.968	8127.100	C6212.377	5127.100	27AH	12SH			
C43629	Teal	605.0	30/19	0.994	8127.106	C6214.441	5127.106	27AH	14SH			
C43630	Swift	636.0	36/1	0.930	8127.100	C6274.148	5127.100	27AH	74SH			
C43631	Kingbird	636.0	18/1	0.940	8127.100	C6275.203	5127.100	27AH	75SH			
C43632	Rook	636.0	24/7	0.977	8127.100	C6212.344	5127.106	27AH	12SH			
C43633	Grosbeak	636.0	26/7	0.990	8121.106	C6212.386	5127.106	27AH	12SH			
C43634	Egret	636.0	30/19	1.019	8127.106C	C6314.453	5127.106	27AH	14SH			
C43635	Flamigo	666.6	24/7	1.000	8127.106C	C6312.351	5127.106	27AH	12SH			
C43636	—	715.5	24/7	1.036	8130.109	C6312.359	5130.109	30AH	12SH			
C43637	Starling	715.5	26/7	1.051	8130.109	C6314.406	5130.109	30AH	14SH			
C43638	Redwing	715.5	30/19	1.081	8130.116	C6316.500	5130.116	30AH	16SH			
C43639	Coot	795.0	36/1	1.040	8130.109	C6374.160	5130.109	30AH	74SH			
C43640	Tern	795.0	45/7	1.063	8130.116	C6310.277	5130.116	30AH	10SH			
C43641	Condor	795.0	54/7	1.093	8130.116	C6312.386	5130.116	30AH	12SH			
C43642	Drake	795.0	26/7	1.108	8130.116	C6314.432	5130.116	30AH	14SH			
C43643	Mallard	795.0	30/19	1.140	8130.122	C6416.516	5130.122	30AH	16SH			
C43641	Cuckoo	795.0	24/7	1.092	8130.116	C6312.386	5130.116	30AH	12SH			
C43645	Ruddy	900.0	45/7	1.131	8130.122	C6410.302	5130.122	30AH	10SH			
C43646	Canary	900.0	54/7	1.162	8130.122	C6414.406	5130.122	30AH	14SH			

Compression Dead Ends—43600 Series for ACSR Conductor, Adjustable Clevis Type, Single Tongue (cont.)

DEAD END ASSEMBLY CATALOG NUMBER	CODE WORD	CONDUCTOR			ALUMINUM BODY SINGLE TONGUE	ADJUSTABLE STEEL CLEVIS	15° TERMINAL CONNECTOR	DIE SIZE		DIMENSION L		PAD SIZE
		SIZE	STRANDING	DIA.				ALUMINUM HEX DIES	STEEL HEX DIES	IN	MM	
		KCMIL	AL/ST	IN								
C43647	Catbird	954.0	36/1	1.140	8130.122	C6475.179	5130.122	30AH	15SH			
C43648	Rail	954.0	45/7	1.165	8130.122	C6410.302	5130.122	30AH	10SH			
C43650	Cardinal	954.0	54/7	1.196	8130.125	C6414.422	5130.125	30AH	14SH			
C43651	Tanager	1033.5	36/1	1.186	8130.125	C6475.184	5130.125	30AH	75SH			
C43652	Ortolan	1033.5	45/7	1.212	8134.128	C6410.316	5134.128	34AH	10SH			
C43654	Curllew	1033.5	54/7	1.244	8134.134	C6414.432	5134.134	34AH	14SH			
C43655	Bluejay	1113.0	45/7	1.259	8134.134	C6412.332	5134.134	34AH	12SH			
C43657	Finch	1113.0	54/19	1.293	8134.138	C6414.453	5134.138	34AH	14SH			
C43658	Bunting	1192.5	45/7	1.302	8134.138	C6412.344	5134.138	34AH	12SH			
C43660	Grackle	1192.5	54/19	1.333	8136.144	C6514.453	5136.144	36AH	14SH			
C43661	Bittern	1272.0	45/7	1.345	8136.144	C6512.351	5136.144	36AH	12SH			
C43663	Pheasant	1272.0	54/19	1.382	8136.147	C6516.500	5136.147	36AH	16SH			
C43664	Dipper	1351.5	45/7	1.385	8136.147	C6512.377	5136.147	36AH	12SH			
C43666	Martin	1351.5	54/19	1.424	8139.150	C6516.500	5138.150	38AH	16SH			
C43667	Bobolink	1431.0	45/7	1.427	8138.150	C6512.377	5138.150	38AH	12SH			
C43669	Plover	1431.0	54/19	1.465	8138.156	C6516.516	5130.156	36AH	16SH			
C43670	Nuthatch	1510.5	45/7	1.466	8138.156	C6512.386	5138.156	38AH	12SH			
C43672	Parrot	1510.5	54/19	1.506	8140.162	C6616.531	5140.162	40AH	16SH			
C43673	Lapwing	1590.0	45/7	1.504	8140.162	C6612.397	5140.162	40AH	12SH			
C43674	Falcon	1590.0	54/19	1.545	8140.162	C6618.546	5140.162	40AH	18SH			
C43675	Chukar	1780.0	84/19	1.602	8142.178C	C6714.453	5142.178	42AH	14SH			
C43677	—	2034.0	72/7	1.681	8142.178C	C6714.359	5142.178	42AH	14SH			
C43678	Bluebird	2156.0	84/19	1.762	8144.184	C6716.516	5144.184	44AH	16SH			
C43679	Kiwi	2167.0	72/7	1.737	8144.181	C6712.377	5144.181	44AH	12SH			
C43681	Thrasher	2312.0	76/19	1.802	8144.188	C6714.422	5144.188	44AH	14SH			
C43682	Joree	2315.0	76/19	1.880	8148.197	C6814.453	5148.197	48AH	14SH			
C43679	Kiwi	2167.0	72/7	1.737	8144.181	C6712.377	5144.181	44AH	12SH			
C43681	Thrasher	2312.0	76/19	1.802	8144.188	C6714.422	5144.188	44AH	14SH			
C43682	Joree	2315.0	76/19	1.880	8148.197	C6814.453	5148.197	48AH	14SH			

Compression Dead Ends—43800 Series for ACSR Conductor, Adjustable Clevis Type, Double Tongue

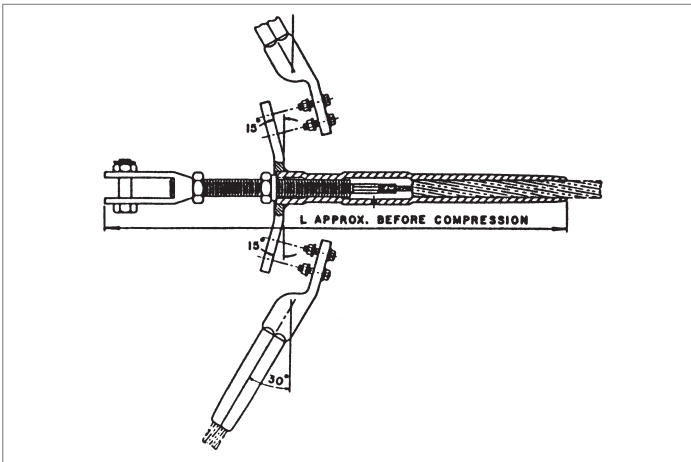

The 43800 Series Adjustable Clevis Dead End assembly is specifically designed for ACSR conductors. The aluminum body of the dead end is fabricated from AFL seamless drawn aluminum. The tongue and terminal pad are constructed with a 15° angle, which permits the terminal connector to be bolted in the straight of 30° position.

All dead ends are designed for full tension use, achieving a minimum of 95% of the ASTM rated strength of the conductor on which they are used. Each dead end assembly comes with a dead end body, adjustable steel clevis, two 15° terminals and aluminum hardware.

For die size sections 30AH and above, the end tapers of the compression portions of all compression accessories are supplied with a high voltage finish. Corona bolts are furnished as standard on 15° terminals for these section sizes.

The square edges of the bolted pads of the compression accessories could cause Corona. Pads with edges and corners rounded can be supplied by adding the catalog suffix "EHV".

Ordering Instructions

Step 1: Assembly Catalog Number

Determine the assembly catalog number based on the conductor being used.

Step 2: Terminal Connector

For an assembly without a terminal connector, use 'NT'.
For an assembly with a terminal connector, leave blank.

Step 3: Extra High Voltage Finish

For Extra High Voltage Finish, use 'EHV'.
For Standard Finish, leave blank.

Step 4: Assemble Catalog Number.



Example:

For 795 Drake conductor with no terminal and EHV finish, the complete catalog number is:

C43842NTEHV

Notes:

1. Adjustable Clevis Dimensions are on page 120.
2. Pad Dimensions are on page 117.
3. AFL Filler Compound (AFC) Requirements are on page 115.
4. Installation Instructions for Dead Ends are on page 129.
5. Installation Instructions for Terminals are on page 131.

Compression Dead Ends—43800 Series for ACSR Conductor, Adjustable Clevis Type, Double Tongue (cont.)

DEAD END ASSEMBLY CATALOG NUMBER	CODE WORD	CONDUCTOR			ALUMINUM BODY DOUBLE TONGUE	ADJUSTABLE STEEL CLEVIS	15° TERMINAL CONNECTOR	DIE SIZE		TOTAL WEIGHT		DIMENSION L		PAD SIZE
		SIZE	STRANDING	DIA.				ALUMINUM HEX DIES	STEEL HEX DIES	LBS	KG	IN	MM	
		KCMIL	AL/ST	IN										
C43813	Linnet	336.4	26/7	0.721	8220.781	C6110.277	5120.781	20AH	10SH	7.6	3.44	30.0	762	B
C43814	Oriole	336.4	30/7	0.741	8220.781	C6110.332	5120.781	20AH	10SH	7.6	3.44	30.0	762	B
C43815	Chickadee	397.5	18/1	0.743	8220.781	C6174.160	5120.781	20AH	74SH	7.3	3.30	30.0	762	B
C43816	Brant	397.5	24/7	0.772	8220.812	C6110.261	5120.812	20AH	10SH	7.3	3.30	29.4	746	B
C43817	Ibis	397.5	26/7	0.783	8220.844	C6110.302	5120.844	20AH	10SH	7.2	3.25	29.4	746	B
C43818	Lark	397.5	30/7	0.806	8220.844	C6112.359	5120.844	20AH	12SH	7.3	3.29	29.4	746	B
C43819	Pelican	477.0	18/1	0.814	8224.875	C6175.179	5124.875	24AH	75SH	8.4	3.82	28.3	718	B
C43820	Flicker	477.0	24/7	0.846	8224.938C	C6210.295	5124.938	24AH	10SH	9.2	4.18	29.6	751	B
C43821	Hawk	477.0	26/7	0.858	8224.938C	C6212.332	5124.938	24AH	12SH	9.4	4.27	29.6	751	B
C43822	Hen	477.0	30/7	0.883	8224.938C	C6212.397	5124.938	24AH	12SH	9.4	4.27	29.6	751	B
C43823	Osprey	556.5	18/1	0.879	8224.938C	C6275.188	5124.938	24AH	75SH	9.2	4.13	29.6	751	B
C43824	Parakeet	556.5	24/7	0.914	8224.969C	C6210.316	5124.969	24AH	10SH	9.5	4.22	30.1	764	B
C43825	Dove	556.5	26/7	0.927	8224.969C	C6212.359	5124.969	24AH	12SH	9.5	4.31	30.1	704	B
C43826	Eagle	556.5	30/7	0.953	8227.100	C6214.432	5127.100	27AH	14SH	11.6	5.26	31.6	802	D
C43827	Peacock	605.0	24/7	0.953	8227.100	C6212.332	5127.100	27AH	12SH	11.4	5.17	31.6	802	D
C43828	Squab	605.0	26/7	0.966	8227.100	C621 2.377	5127.100	27AH	12SH	11.4	5.17	31.6	802	D
C43829	Teal	605.0	30/19	0.994	8227.106	C6214.441	5127.106	27AH	14SH	11.5	5.22	31.6	802	D
C43830	Swift	636.0	36/1	0.930	8227.100	C6274.148	5127.100	27AH	74SH	11.0	5.01	31.6	802	D
C43831	Kingbird	636.0	18/1	0.940	8227.100	C6275.203	5127.100	27AH	75SH	11.1	5.03	31.6	802	D
C43832	Rook	636.0	24/7	0.977	8227.106	C6212.344	5127.106	27AH	12SH	11.3	5.13	31.6	802	D
C43833	Grosbeak	636.0	26/7	0.990	8227.106	C6212.386	5127.106	27AH	12SH	11.3	5.13	31.6	802	D
C43834	Egret	636.0	30/19	1.019	8227.106C	C6314.453	5127.106	27AH	14SH	15.9	6.85	34.0	864	D
C43835	Flamingo	666.6	24/7	1.000	8227.106C	C6312.351	5127.106	27AH	12SH	15.6	6.71	34.0	864	D
C43836	Stilt	715.5	24/7	1.036	8230.109	C6312.359	5130.109	30AH	12SH	16.6	7.57	34.4	873	D
C43837	Starling	715.5	26/7	1.051	8230.109	C6314.406	5130.109	30AH	14SH	15.5	7.71	34.3	871	D
C43838	Redwing	715.5	30/19	1.081	8230.109	C6316.500	5130.116	30AH	16SH	15.6	7.71	34.8	884	D
C43839	Coot	795.0	36/1	1.040	8230.109	C6374.160	5130.109	30AH	74SH	16.4	7.44	34.3	871	D
C43840	Tern	795.0	45/7	1.063	8230.116	C6310.277	5130.116	30AH	10SH	16.4	7.44	34.8	871	D
C43841	Condor	795.0	54/7	1.093	8230.116	C6312.386	5130.116	30AH	12SH	16.5	7.48	34.8	871	D
C43842	Drake	795.0	26/7	1.108	8230.116	C6314.432	5130.116	30AH	14SH	16.8	7.62	34.8	871	D
C43843	Mallard	795.0	30/19	1.140	8230.122	C6416.516	5130.122	30AH	16SH	17.7	8.02	35.4	900	D
C43841	Cuckoo	795.0	24/7	1.092	8230.116	C6312.386	5130.116	30AH	12SH	16.5	7.48	34.8	871	D
C43845	Ruddy	900.0	45/7	1.131	8230.122	C6410.302	5130.122	30AH	10SH	13.0	7.71	35.4	900	D
C43846	Canary	900.0	54/7	1.162	8230.122	C6414.406	5130.122	30AH	14SH	17.4	7.89	35.4	900	D
C43847	Catbird	954.0	36/1	1.140	8230.122	C6475.179	5130.122	30AH	75SH	16.9	7.66	35.4	900	D
C43848	Rail	954.0	45/7	1.165	8230.122	C6410.302	5130.122	30AH	10SH	17.0	7.71	35.4	900	D
C43850	Cardinal	954.0	54/7	1.196	8230.125	C6414.422	5130.125	30AH	14SH	17.4	7.89	36.2	919	D
C43851	Tanager	1033.5	36/1	1.186	8230.125	C6475.184	5130.125	30AH	75SH	16.9	7.66	36.2	919	D
C43852	Ortolan	1033.5	45/7	1.212	8234.128	C6410.316	5134.128	34AH	10SH	19.8	8.98	36.4	926	D
C43854	Curlew	1033.5	54/7	1.244	8234.134	C6414.432	5134.134	34AH	14SH	21.6	8.89	37.1	943	D

Compression Dead Ends—43800 Series for ACSR Conductor, Adjustable Clevis Type, Double Tongue (cont.)

DEAD END ASSEMBLY CATALOG NUMBER	CODE WORD	CONDUCTOR			ALUMINUM BODY DOUBLE TONGUE	ADJUSTABLE STEEL CLEVIS	15° TERMINAL CONNECTOR	DIE SIZE		TOTAL WEIGHT		DIMENSION L		PAD SIZE
		SIZE	STRANDING	DIA.				ALUMINUM HEX DIES	STEEL HEX DIES	LBS	KG	IN	MM	
		KCMIL	AL/ST	IN										
C43855	Bluejay	1113.0	45/7	1.259	8234.134	C6412.332	5134.134	34AH	12SH	19.4	8.80	37.1	943	D
C43857	Finch	1113.0	54/19	1.293	8234.138	C6414.453	5134.138	34AH	14SH	19.2	8.71	37.1	941	D
C43858	Bunting	1192.5	45/7	1.302	8234.138	C6412.344	5134.138	34AH	12SH	19.0	8.62	37.1	941	D
C43860	Grackle	1192.5	54/19	1.333	8236.144	C6514.453	5136.144	36AH	14SH	21.6	9.82	37.4	949	D
C43861	Bittern	1272.0	45/7	1.345	8236.144	C6512.351	5136.144	36AH	12SH	21.4	9.73	37.4	949	D
C43863	Pheasant	1272.0	54/19	1.382	8236.147	C6516.500	5136.147	36AH	16SH	21.5	9.75	37.6	956	D
C43864	Dipper	1351.5	45/7	1.385	8236.147	C6512.377	5136.147	36AH	12SH	21.0	9.53	37.6	956	D
C43866	Martin	1351.5	54/19	1.424	8238.150	C6516.500	5138.150	38AH	16SH	23.5	9.85	37.9	962	D
C43867	Bobolink	1431.0	45/7	1.427	8238.150	C6512.377	5138.150	38AH	12SH	23.0	10.43	37.9	962	D
C43869	Plover	1431.0	54/19	1.465	8238.156	C6516.516	5138.156	36AH	16SH	23.1	10.48	37.9	962	D
C43870	Nuthatch	1510.5	45/7	1.466	8238.156	C6512.386	5138.156	38AH	12SH	22.6	10.26	37.9	962	D
C43872	Parrot	1510.5	54/19	1.506	8240.162	C6616.531	5140.162	40AH	16SH	31.1	14.10	41.3	1049	E
C43873	Lapwing	1590.0	45/7	1.504	8240.162	C6612.397	5140.162	40AH	12SH	30.6	13.88	41.3	1049	E
C43874	Falcon	1590.0	54/19	1.545	8240.162	C6618.546	5140.162	40AH	18SH	31.5	14.36	41.3	1049	E
C43875	Chukar	1780.0	84/19	1.602	8242.178C	C6714.453	5142.178	42AH	14SH	31.7	14.38	42.7	1084	E
C43877	—	2034.0	72/7	1.681	8242.178C	C6714.359	5142.178	42AH	14SH	31.7	14.68	42.7	1084	E
C43878	Bluebird	2156.0	84/19	1.762	8244.184	C6716.516	5144.184	44AH	16SH	32.3	14.65	40.3	1022	E
C43879	Kiwi	2167.0	72/7	1.737	8244.181	C6712.377	5144.181	44AH	12SH	32.6	14.78	42.3	1073	E
C43881	Thrasher	2312.0	76/19	1.802	8244.188	C6714.422	5144.188	44AH	14SH	32.1	14.56	43.3	1099	E
C43882	Joree	2515.0	76/19	1.880	8248.197	C6814.453	5148.197	48AH	14SH	45.1	20.46	45.2	1148	E
C43879	Kiwi	2167.0	72/7	1.737	8244.181	C6712.377	5144.181	44AH	12SH	32.6	14.78	42.3	1073	E
C43881	Thrasher	2312.0	76/19	1.802	8244.188	C6714.422	5144.188	44AH	14SH	32.1	14.56	43.3	1099	E
C43882	Joree	2515.0	76/19	1.880	8248.197	C6814.453	5148.197	48AH	14SH	45.1	20.46	45.2	1148	E

Compression Joints—33000 Series for ACSR Conductors

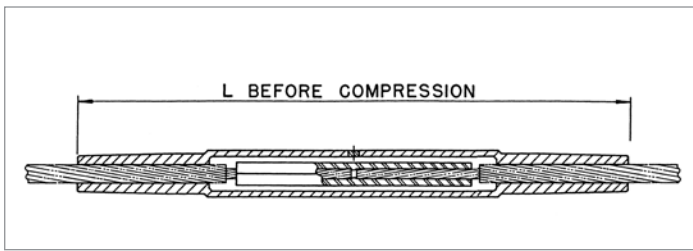

Ordering Instructions

Step 1: Assembly Catalog Number

Determine the assembly catalog number based on the conductor being used.

Example:

For 795 Drake ACSR conductor, the complete catalog number is:

33043

The 33000 Series Compression Joint Assembly is specifically designed for ACSR conductors. The aluminum body is fabricated from AFL seamless drawn aluminum.

All compression joints are designed for full tension use, achieving a minimum of 95% of the ASTM rated strength of the conductor on which they are used. Each compression joint assembly comes with an aluminum joint and a steel sleeve.

For die size sections 30AH and above, the end tapers of the compression portions of all compression accessories are supplied with a high voltage finish.

JOINT ASSEMBLY CATALOG NUMBER	CONDUCTOR				ALUMINUM JOINT CATALOG NUMBER	STEEL JOINT CATALOG NUMBER	DIE SIZE		WEIGHT				DIMENSION L	
	CODE WORD	AWG OR KCMIL	STRANDING AL/ST	DIA. IN			ALUMINUM HEX DIE	STEEL HEX DIE	ALUMINUM		STEEL		IN	MM
									LBS	KG	LBS	KG		
33006	Raven	1/0	6/1	0.398	8074.438	4074.148	74AH	74SH	0.7	0.31	0.1	0.05	19.3	489
33007	Quail	2/0	6/1	0.447	8074.484	4074.160	74AH	74SH	0.6	0.28	0.1	0.05	19.3	489
33008	Pigeon	3/0	6/1	0.502	8075.547	4075.179	75AH	75SH	1.1	0.50	0.2	0.07	21.5	546
33009	Penguin	4/0	6/1	0.563	8075.609	4075.228	75AH	75SH	1.0	0.44	0.1	0.06	21.5	546
33010	Waxwing	266.8	18/1	0.609	8076.656	4074.132	76AH	74SH	1.9	0.86	0.1	0.04	25.8	654
33011	Owl	266.8	6/7	0.633	8076.688	4076.221	76AH	76SH	1.8	0.82	0.3	0.12	25.8	654
33012	Partridge	266.8	26/7	0.642	8076.688	4076.246	76AH	76SH	1.8	0.82	0.3	0.12	25.8	654
33081	Ostrich	300.0	26/7	0.680	8076.719	4076.261	76AH	76SH	1.7	0.86	0.3	0.11	25.8	654
33013	Merlin	336.4	18/1	0.684	8076.719	4074.148	76AH	74SH	1.7	0.86	0.1	0.05	25.8	654
33014	Linnet	336.4	26/7	0.721	8020.781	4010.277	20AH	10SH	2.0	0.91	0.4	0.19	28.9	734
33015	Oriole	336.4	30/7	0.741	8020.781	4010.332	20AH	10SH	2.0	0.91	0.5	0.21	28.9	734
33016	Chickadee	397.5	18/1	0.743	8020.781	4074.160	20AH	74SH	2.0	0.91	0.1	0.05	28.9	734
33082	Brant	397.5	24/7	0.772	8020.812	4010.261	20AH	10SH	1.9	0.86	0.4	0.20	27.2	691
33017	Ibis	397.5	26/7	0.783	8020.844	4010.302	20AH	10SH	1.7	0.77	0.5	0.23	27.2	691
33018	Lark	397.5	30/7	0.806	8020.844	4012.359	20AH	12SH	1.7	0.77	0.7	0.34	27.2	691
33020	Pelican	477.0	18/1	0.814	8024.875	4075.179	24AH	75SH	2.4	1.09	0.2	0.09	21.0	533

Notes:

1. AFL Filler Compound (AFC) Requirements are on page 115.
2. Installation Instructions for Joints are on page 137.

Compression Joints—33000 Series for ACSR Conductors (cont.)

JOINT ASSEMBLY CATALOG NUMBER	CONDUCTOR				ALUMINUM JOINT CATALOG NUMBER	STEEL JOINT CATALOG NUMBER	DIE SIZE		WEIGHT				DIMENSION L	
	CODE WORD	AWG OR KCMIL	STRANDING	DIA.			ALUMINUM HEX DIE	STEEL HEX DIE	ALUMINUM		STEEL		IN	MM
			AL/ST	IN					LBS	KG	LBS	KG		
33021	Flicker	477.0	24/7	0.846	8024.938	4010.295	24AH	10SH	2.9	1.32	0.4	0.20	27.1	689
33022	Hawk	477.0	26/7	0.858	8024.938	4012.332	24AH	12SH	2.9	1.32	0.8	0.34	27.1	689
33023	Hen	477.0	30/7	0.883	8024.938	4012.397	24AH	12SH	2.9	1.32	0.8	0.37	27.1	689
33024	Osprey	556.5	18/1	0.879	8024.938	4075.188	24AH	75SH	2.9	1.32	0.1	0.06	27.1	689
33025	Parakeet	556.5	24/7	0.914	8024.969	4010.316	24AH	10SH	2.8	1.27	0.5	0.22	27.2	691
33026	Dove	556.5	26/7	0.927	8024.969	4012.359	24AH	12SH	2.8	1.27	0.7	0.34	27.2	691
33027	Eagle	556.5	30/7	0.953	8027.100	4014.432	27AH	14SH	4.4	2.00	1.3	0.59	30.4	772
33028	Peacock	605.0	24/7	0.953	8027.100	4012.332	27AH	12SH	4.4	2.00	0.8	0.34	30.4	772
33029	Squab	605.0	26/7	0.966	8027.100	4012.377	27AH	12SH	4.4	2.00	0.8	0.38	30.4	772
33030	Teal	605.0	30/19	0.994	8027.106	4014.441	27AH	14SH	4.1	1.86	1.3	0.59	31.0	787
33083	Swift	636.0	36/1	0.930	8027.100	4074.148	27AH	74SH	4.4	2.00	0.1	0.05	30.4	772
33031	Kingbird	636.0	18/1	0.940	8027.100	4075.228	27AH	75SH	4.4	2.00	0.1	0.06	30.4	772
33032	Rook	636.0	24/7	0.977	8027.106	4012.344	27AH	12SH	4.1	1.86	0.7	0.33	31.0	787
33033	Grosbeak	636.0	26/7	0.990	8027.106	4012.386	27AH	12SH	4.1	1.86	0.8	0.37	31.0	787
33034	Egret	636.0	30/19	1.019	8027.106	4014.453	27AH	14SH	4.1	1.86	1.2	0.54	31.0	787
33035	Flamingo	666.6	24/7	1.000	8027.106	4012.351	27AH	12SH	4.1	1.86	0.8	0.35	31.0	787
33084	Stilt	715.5	24/7	1.036	8030.109	4012.359	30AH	12SH	5.1	2.31	0.7	0.34	30.0	762
33037	Starling	715.5	26/7	1.051	8030.109	4014.406	30AH	14SH	5.1	2.31	1.2	0.54	30.0	762
33038	Redwing	715.5	30/19	1.081	8030.116	4016.500	30AH	16SH	5.1	2.31	1.7	0.77	32.1	816
33039	Coot	795.0	36/1	1.040	8030.109	4074.160	30AH	74SH	5.1	2.31	0.1	0.05	30.0	762
33040	Tern	795.0	45/7	1.063	8030.116	4010.277	30AH	10SH	5.1	2.31	0.4	0.19	32.1	816
33042	Condor	795.0	54/7	1.093	8030.116	4012.386	30AH	12SH	5.1	2.31	0.8	0.37	32.1	816
33043	Drake	795.0	26/7	1.108	8030.116	4014.432	30AH	14SH	5.1	2.31	1.3	0.59	32.1	816
33044	Mallard	795.0	30/19	1.140	8030.122	4016.516	30AH	16SH	5.1	2.31	1.6	0.73	34.0	864
33085	Cuckoo	795.0	24/7	1.092	8030.116	4012.386	30AH	12SH	5.1	2.31	0.9	0.39	32.1	816
33047	Ruddy	900.0	45/7	1.131	8030.122	4010.302	30AH	10SH	5.1	2.31	0.5	0.23	34.0	864
33046	Canary	900.0	54/7	1.162	8030.122	4014.406	30AH	14SH	5.1	2.31	1.2	0.54	34.0	864
33086	Catbird	954.0	36/1	1.140	8030.122	4075.179	30AH	75SH	5.1	2.31	0.2	0.07	34.0	864
33047	Rail	954.0	45/7	1.165	8030.122	4010.302	30AH	10SH	5.1	2.31	0.5	0.23	34.0	864
33049	Cardinal	954.0	54/7	1.196	8030.125	4014.422	30AH	14SH	4.9	2.22	1.2	0.54	34.2	868
33087	Tanager	1033.5	36/1	1.186	8030.125	4075.179	30AH	75SH	4.9	2.22	0.2	0.07	34.2	868
33050	Ortolan	1033.5	45/7	1.212	8034.128	4010.316	34AH	10SH	7.2	3.27	0.5	0.22	34.1	867
33052	Curlew	1033.5	54/7	1.244	8034.134	4014.432	34AH	14SH	7.1	3.22	1.3	0.59	36.8	933
33053	Bluejay	1113.0	45/7	1.259	8034.134	4012.332	34AH	12SH	7.1	3.22	0.8	0.34	36.8	933
33055	Finch	1113.0	54/19	1.293	8034.138	4014.453	34AH	14SH	7.4	3.36	1.2	0.54	37.0	940
33056	Bunting	1192.5	45/7	1.302	8034.138	4012.344	34AH	12SH	7.4	3.36	0.7	0.33	37.0	940
33058	Grackle	1192.5	54/19	1.333	8036.144	4014.453	36AH	14SH	8.2	3.72	1.2	0.54	37.5	953
33059	Bittern	1272.0	45/7	1.345	8036.144	4012.351	36AH	12SH	8.2	3.72	0.8	0.35	37.5	953
33061	Pheasant	1272.0	54/19	1.382	8036.147	4016.500	36AH	16SH	8.0	3.63	1.7	0.77	38.0	965
33062	Dipper	1351.5	45/7	1.385	8036.147	4012.377	36AH	12SH	8.0	3.63	0.8	0.36	38.0	965
33064	Martin	1351.5	54/19	1.424	8038.150	4016.500	38AH	16SH	9.5	4.31	1.7	0.77	38.4	975
33065	Bobolink	1431.0	45/7	1.427	8038.150	4012.377	38AH	12SH	9.5	4.31	0.8	0.36	38.4	975

Compression Joints—33000 Series for ACSR Conductors (cont.)

JOINT ASSEMBLY CATALOG NUMBER	CONDUCTOR				ALUMINUM JOINT CATALOG NUMBER	STEEL JOINT CATALOG NUMBER	DIE SIZE		WEIGHT				DIMENSION L	
	CODE WORD	AWG OR KCMIL	STRANDING	DIA.			ALUMINUM HEX DIE	STEEL HEX DIE	ALUMINUM		STEEL		IN	MM
			AL/ST	IN					LBS	KG	LBS	KG		
33067	Plover	1431.0	54/19	1.465	8038.156	4016.516	38AH	16SH	9.0	4.08	1.6	0.73	38.4	975
33068	Nuthatch	1510.5	45/7	1.466	8038.156	4012.388	38AH	12SH	9.0	4.08	0.8	0.37	38.4	975
33070	Parrot	1510.5	54/19	1.506	8040.162	4016.531	40AH	16SH	10.4	4.72	1.6	0.73	39.0	991
33071	Lapwing	1590.0	45/7	1.504	8040.162	4012.397	40AH	12SH	10.4	4.72	0.8	0.37	39.0	991
33072	Falcon	1590.0	54/19	1.545	8040.162	4018.546	40AH	18SH	10.4	4.72	2.1	0.95	39.0	991
33073	Chukar	1780.0	84/19	1.602	8042.178	4014.453	42AH	14SH	11.0	4.99	1.2	0.54	40.3	1022
33075	—	2034.0	72/7	1.681	8042.178	4014.359	42AH	14SH	11.0	4.99	1.4	0.64	40.3	1022
33076	Bluebird	2156.0	84/19	1.762	8044.184	4016.516	44AH	16SH	11.3	5.13	1.6	0.73	36.6	930
33077	Kiwi	2167.0	72/7	1.737	8044.181	4012.377	44AH	12SH	12.3	5.58	0.8	0.36	39.3	997
33078	Thrasher	2312.0	76/19	1.802	8044.188	4014.422	44AH	14SH	12.0	5.44	1.2	0.54	40.3	1022
33080	Joree	2515.0	76/19	1.880	8048.197	4014.453	48AH	14SH	17.1	7.76	1.2	0.54	44.5	1130

Compression Joints – Jiffy Joints—7500 Series for ACSR Conductors

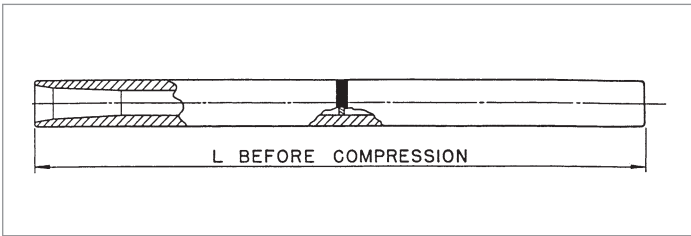

The 7500 Series Compression Joint (Jiffy Joint) is designed for ACSR conductors. The aluminum body is fabricated from AFL seamless drawn aluminum. The compression joint is a single piece unit without a steel sleeve and comes prefilled with AFL Filler Compound (AFC).

All compression joints are designed for full tension use, achieving a minimum of 95% of the ASTM rated strength of the conductor on which they are used.

For die size sections 30AH and above, the end tapers of the compression portions of all compression accessories are supplied with a high voltage finish.

Ordering Instructions

Step 1: Assembly Catalog Number

Determine the assembly catalog number based on the conductor being used.

Example:

For 336.4 Merlin conductor, the complete catalog number is:

7514.719

JOINT CATALOG NUMBER	CONDUCTOR				DIE SIZE ALUMINUM HEX DIES	WEIGHT		COLOR CODE	DIMENSION L	
	CODE NAME	AWG OR KCMIL	STRANDING	DIA.		LBS	KG		IN	MM
			AL/ST	IN						
7511.453	Raven	1/0	6/1	0.398	11AH	0.6	0.28	Yellow	14.0	356
7512.484	Quall	2/0	6/1	0.447	12AH	0.8	0.37	Gray	14.0	356
7513.542	Pigeon	3/0	6/1	0.502	13AH	1.1	0.50	Black	14.0	356
7513.625	Penguin	4/0	6/1	0.563	13AH	1.1	0.50	Pink	16.0	406
7514.719	Merlin	336.4	18/1	0.664	14AH	1.6	0.73	Clear	15.6	395
7524.871	Chickadee	397.5	18/1	0.743	24AH	2.8	1.27	Clear	19.6	497
7524.875	Pelican	477.0	18/1	0.814	24AH	2.8	1.27	Clear	22.1	560

Notes:

1. Joints are prefilled with compound.
2. Installation Instructions for Joints are on page 137.

Repair Sleeves—5200 Series for ACSR Conductors

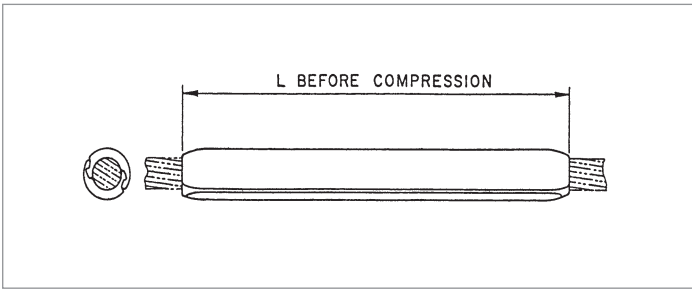

Ordering Instructions

Step 1: Assembly Catalog Number

Determine the assembly catalog number based on the conductor being used.

Example:

For 795 Drake conductor, the complete catalog number is:

5230.3

The 5200 Series Repair Sleeve is designed for ACSR conductors. The repair sleeve incorporates an improved design of interlocking extrusions, providing a permanent grip on the conductor when compressed.

The repair sleeve will restore 95% of the rated strength of the conductor with up to one-third of the aluminum strands damaged.

REPAIR SLEEVE CATALOG NUMBER	CONDUCTOR				DIE SIZE	WEIGHT		DIMENSION L	
	CODE NAME	SIZE	STRANDING	DIA.	ALUMINUM HEX DIES	LBS	KG	IN	MM
		KCMIL	AL/ST	IN					
5274	Raven	1/0	6/1	0.398	74AH	0.2	0.10	7.6	192
5274	Quail	2/0	6/1	0.447	74AH	0.2	0.10	7.6	192
5275	Pigeon	3/0	6/1	0.502	75AH	0.4	0.18	8.6	217
5275	Penguin	4/0	6/1	0.563	75AH	0.4	0.18	8.6	217
5276	Waxwing	266.8	18/1	0.609	76AH	0.7	0.30	10.0	254
5276	Owl	266.8	6/7	0.633	76AH	0.7	0.30	10.0	254
5276	Partridge	266.8	26/7	0.642	76AH	0.7	0.30	10.0	254
5276	Ostrich	300.0	26/7	0.680	76AH	0.7	0.30	10.0	254
5276	Merlin	336.4	18/1	0.684	76AH	0.7	0.30	10.0	254
5276	Linnet	336.4	26/7	0.720	76AH	0.7	0.30	10.0	254
5276	Chickadee	397.5	18/1	0.743	76AH	0.7	0.30	10.0	254
5220.3	Linnet	336.4	26/7	0.720	20AH	1.0	0.45	14.5	368
5220.3	Oriole	336.4	30/7	0.741	20AH	1.0	0.45	14.5	368
5220.3	Chickadee	397.5	18/1	0.743	20AH	1.0	0.45	14.5	368
5220.3	Brant	397.5	24/7	0.772	20AH	1.0	0.45	14.5	368
5220.3	Ibis	397.5	26/7	0.783	20AH	1.0	0.45	14.5	368

Notes:

1. AFL Filler Compound (AFC) Requirements are on page 115.
2. Installation Instructions for Repair Sleeves are on page 142.

Repair Sleeves—5200 Series for ACSR Conductors (cont.)

REPAIR SLEEVE CATALOG NUMBER	CODE NAME	CONDUCTOR			DIE SIZE	WEIGHT		DIMENSION L	
		SIZE	STRANDING	DIA.	ALUMINUM HEX DIES	LBS	KG	IN	MM
		KCMIL	AL/ST	IN					
5220.3	Lark	397.5	30/7	0.806	20AH	1.0	0.45	14.5	368
5224.3	Pelican	477.0	18/1	0.814	24AH	1.7	0.77	15.5	394
5224.3	Flicker	477.0	24/7	0.846	24AH	1.7	0.77	15.5	394
5224.3	Hawk	477.0	26/7	0.858	24AH	1.7	0.77	15.5	394
5224.3	Hen	477.0	30/7	0.883	24AH	1.7	0.77	15.5	394
5224.3	Osprey	556.5	18/1	0.879	24AH	1.7	0.77	15.5	394
5224.3	Parakeet	556.5	24/7	0.914	24AH	1.7	0.77	15.5	394
5224.3	Dove	556.5	26/7	0.927	24AH	1.7	0.77	15.5	394
5227.3	Eagle	556.5	30/7	0.953	27AH	2.6	1.18	18.3	464
5227.3	Peacock	605.0	24/7	0.953	27AH	2.6	1.18	18.3	464
5227.3	Squab	605.0	26/7	0.966	27AH	2.6	1.18	18.3	464
5227.3	Teal	605.0	30/19	0.994	27AH	2.6	1.18	18.3	464
5227.3	Swift	636.0	36/1	0.930	27AH	2.6	1.18	18.3	464
5227.3	Kingbird	636.0	18/1	0.940	27AH	2.6	1.18	18.3	464
5227.3	Rook	636.0	24/7	0.977	27AH	2.6	1.18	18.3	464
5227.3	Grosbeak	636.0	26/7	0.990	27AH	2.6	1.18	18.3	464
5227.3	Egret	636.0	30/19	1.019	27AH	2.6	1.18	18.3	464
5227.3	Flamingo	666.6	24/7	1.000	27AH	2.6	1.18	18.3	464
5230.3	Stilt	715.5	24/7	1.036	30AH	3.0	1.36	19.1	486
5230.3	Starling	715.5	26/7	1.051	30AH	3.0	1.36	19.1	486
5230.3	Redwing	715.5	30/19	1.081	30AH	3.0	1.36	19.1	486
5230.3	Coot	795.0	36/1	1.040	30AH	3.0	1.36	19.1	486
5230.3	Tern	795.0	45/7	1.063	30AH	3.0	1.36	19.1	486
5230.3	Condor	795.0	54/7	1.093	30AH	3.0	1.36	19.1	486
5230.3	Drake	795.0	26/7	1.108	30AH	3.0	1.36	19.1	486
5230.3	Mallard	795.0	30/19	1.140	30AH	3.0	1.36	19.1	486
5230.3	Cuckoo	795.0	24/7	1.092	30AH	3.0	1.36	19.1	486
5230.3	Ruddy	900.0	45/7	1.131	30AH	3.0	1.36	19.1	486
5230.3	Canary	900.0	54/7	1.162	30AH	3.0	1.36	19.1	486
5230.3	Catbird	954.0	36/1	1.140	30AH	3.0	1.36	19.1	486
5230.3	Rail	954.0	45/7	1.165	30AH	3.0	1.36	19.1	486
5230.3	Cardinal	954.0	54/7	1.196	30AH	3.0	1.36	19.1	486
5230.3	Tanager	1033.5	36/1	1.186	30AH	3.0	1.36	19.1	486
5234.3	Ortolan	1033.5	45/7	1.212	34AH	4.2	1.91	20.1	511

Repair Sleeves—5200 Series for ACSR Conductors (cont.)

REPAIR SLEEVE CATALOG NUMBER	CODE NAME	CONDUCTOR			DIE SIZE	WEIGHT		DIMENSION L	
		SIZE	STRANDING	DIA.	ALUMINUM HEX DIES	LBS	KG	IN	MM
		KCMIL	AL/ST	IN					
5234.3	Curlew	1033.5	54/7	1.244	34AH	4.2	1.91	20.1	511
5234.3	Bluejay	1113.0	45/7	1.259	34AH	4.2	1.91	20.1	511
5234.3	Bunting	1192.5	45/7	1.302	34AH	4.2	1.91	20.1	511
5236.3	Bittern	1272.0	45/7	1.345	36AH	4.4	2.00	21.0	533
5236.3	Pheasant	1272.0	54/19	1.382	36AH	4.4	2.00	21.0	533
5236.3	Dipper	1351.5	45/7	1.386	36AH	4.4	2.00	21.0	533
5238.3	Martin	1351.5	54/19	1.424	38AH	5.2	2.36	21.9	556
5238.3	Bobolink	1431.0	45/7	1.427	38AH	5.2	2.36	21.9	556
5238.3	Plover	1431.0	54/19	1.465	38AH	5.2	2.36	21.9	556
5238.3	Nuthatch	1510.5	45/7	1.466	38AH	5.2	2.36	21.9	556
5240.3	Parrot	1510.5	54/19	1.506	40AH	6.1	2.77	22.8	578
5240.3	Lapwing	1590.0	45/7	1.504	40AH	6.1	2.77	22.8	578
5240.3	Falcon	1590.0	54/19	1.545	40AH	6.1	2.77	22.8	578
5242.3	Chukar	1780.0	84/19	1.602	42AH	6.8	3.08	23.6	600
5244.3	—	2034.0	72/7	1.681	44AH	8.7	3.95	24.5	622
5244.3	Bluebird	2156.0	84/19	1.762	44AH	8.7	3.95	24.5	622
5244.3	Kiwi	2167.0	72/7	1.737	44AH	8.7	3.95	24.5	622
5244.3	Thrasher	2312.0	76/19	1.802	44AH	8.7	3.95	24.5	622
5248.3	Joree	2515.0	76/19	1.880	48AH	9.1	4.13	24.5	622

Jumper Connectors—5000 Series for ACSR Conductors

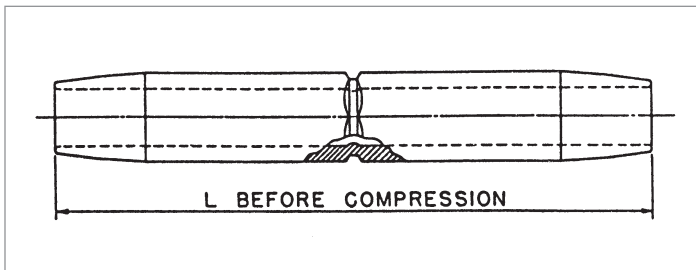

Ordering Instructions

Step 1: Assembly Catalog Number

Determine the assembly catalog number based on the conductor being used.

Example:

For 795 Drake conductor, the complete catalog number is:

5030.116

The 5000 Series Jumper Connector is designed for ACSR conductors. The jumper connector is fabricated from AFL seamless drawn aluminum. All jumper connectors are designed for limited tension use, maintaining a minimum of 40% of the ASTM rated strength of the conductor on which it is being used.

For die size sections 30AH and above, the end tapers of the compression portions of all compression accessories are supplied with a high voltage finish.

JUMPER CONNECTOR CATALOG NUMBER	CONDUCTOR				DIE SIZE ALUMINUM HEX DIES	TOTAL WEIGHT		DIMENSION L	
	CODE NAME	SIZE	STRANDING	DIA.		LBS	KG	IN	MM
		KCMIL	AL/ST	IN					
5074.438	Raven	1/0	6/1	0.398	74AH	0.3	0.11	7.0	178
5074.484	Quail	2/0	6/1	0.447	74AH	0.2	0.10	7.0	178
5075.547	Pigeon	3/0	6/1	0.502	75AH	0.4	0.20	8.0	203
5075.609	Penguin	4/0	6/1	0.563	75AH	0.4	0.18	8.0	203
5076.656	Waxwing	266.8	18/1	0.609	76AH	0.7	0.31	9.0	229
5076.688	Owl	266.8	6/7	0.633	76AH	0.7	0.29	9.0	229
5076.688	Partridge	266.8	26/7	0.642	76AH	0.7	0.29	9.0	229
5076.719	Ostrich	300.0	26/7	0.680	76AH	0.6	0.28	9.0	229
5076.719	Merlin	336.4	18/1	0.684	76AH	0.6	0.28	9.0	229
5076.781	Linnet	336.4	26/7	0.720	76AH	0.6	0.27	9.0	229
5076.781	Chickadee	397.5	18/1	0.743	76AH	0.6	0.27	9.0	229
5020.781	Linnet	336.4	26/7	0.720	20AH	0.7	0.33	10.0	254
5020.781	Oriole	336.4	30/7	0.741	20AH	0.7	0.33	10.0	254
5020.781	Chickadee	397.5	18/1	0.743	20AH	0.7	0.33	10.0	254
5020.812	Brant	397.5	24/7	0.772	20AH	0.7	0.31	10.0	254
5020.844	Ibis	397.5	26/7	0.783	20AH	0.6	0.29	10.0	254
5020.844	Lark	397.5	30/7	0.806	20AH	0.6	0.29	10.0	254
5024.875	Pelican	477.0	18/1	0.814	24AH	1.2	0.54	11.0	279

Notes:

1. AFL Filler Compound (AFC) Requirements are on page 115.
2. Installation Instructions for Jumper Connectors are on page 143.

Jumper Connectors—5000 Series for ACSR Conductors (cont.)

JUMPER CONNECTOR CATALOG NUMBER	CONDUCTOR				DIE SIZE ALUMINUM HEX DIES	TOTAL WEIGHT		DIMENSION L	
	CODE NAME	SIZE	STRANDING	DIA.		LBS	KG	IN	MM
		KCMIL	AL/ST	IN					
5024.938	Flicker	477.0	24/7	0.846	24AH	1.1	0.50	11.0	279
5024.938	Hawk	477.0	26/7	0.858	24AH	1.1	0.50	11.0	279
5024.938	Hen	477.0	30/7	0.883	24AH	1.1	0.50	11.0	279
5024.938	Osprey	556.5	18/1	0.879	24AH	1.1	0.50	11.0	279
5024.969	Parakeet	556.5	24/7	0.914	24AH	1.0	0.45	11.0	279
5024.969	Dove	556.5	26/7	0.927	24AH	1.0	0.45	11.0	279
5027.100	Eagle	556.5	30/7	0.953	27AH	1.6	0.73	12.0	305
5027.100	Peacock	605.0	24/7	0.953	27AH	1.6	0.73	12.0	305
5027.100	Squab	605.0	26/7	0.966	27AH	1.6	0.73	12.0	305
5027.100	Swift	636.0	36/1	0.930	27AH	1.6	0.73	12.0	305
5027.100	Kingbird	636.0	18/1	0.940	27AH	1.6	0.73	12.0	305
5027.106	Teal	605.0	30/19	0.994	27AH	1.5	0.68	12.0	305
5027.106	Rook	636.0	24/7	0.977	27AH	1.5	0.68	12.0	305
5027.106	Grosbeak	636.0	26/7	0.990	27AH	1.5	0.68	12.0	305
5027.106	Egret	636.0	30/19	1.019	27AH	1.5	0.68	12.0	305
5027.106	Flamingo	666.6	24/7	1.000	27AH	1.5	0.68	12.0	305
5030.109	Stilt	715.5	24/7	1.036	30AH	2.1	0.95	13.0	330
5030.109	Starling	715.5	26/7	1.051	30AH	2.1	0.95	13.0	330
5030.116	Redwing	715.5	30/19	1.081	30AH	2.0	0.91	13.0	330
5030.109	Coot	795.0	36/1	1.040	30AH	2.1	0.95	13.0	330
5030.116	Tern	795.0	45/7	1.063	30AH	2.0	0.91	13.0	330
5030.116	Condor	795.0	54/7	1.093	30AH	2.0	0.91	13.0	330
5030.116	Drake	795.0	26/7	1.108	30AH	2.0	0.91	13.0	330
5030.122	Mallard	795.0	30/19	1.140	30AH	1.8	0.82	13.0	330
5030.116	Cuckoo	795.0	24/7	1.092	30AH	2.0	0.91	13.0	330
5030.122	Ruddy	900.0	45/7	1.131	30AH	1.8	0.82	13.0	330
5030.122	Canary	900.0	54/7	1.162	30AH	1.8	0.82	13.0	330
5030.122	Catbird	954.0	36/1	1.140	30AH	1.8	0.82	13.0	330
5030.122	Rail	954.0	45/7	1.165	30AH	1.8	0.82	13.0	330
5030.125	Cardinal	954.0	54/7	1.196	30AH	1.8	0.82	13.0	330
5030.125	Tanager	1033.5	36/1	1.186	30AH	1.8	0.82	13.0	330
5034.128	Ortolan	1033.5	45/7	1.212	34AH	2.8	1.27	14.0	356
5034.134	Curlew	1033.5	54/7	1.244	34AH	2.6	1.18	14.0	356
5034.134	Bluejay	1113.0	45/7	1.259	34AH	2.6	1.18	14.0	356
5034.138	Bunting	1192.5	45/7	1.302	34AH	2.5	1.13	14.0	356
5036.144	Bittern	1272.0	45/7	1.345	36AH	3.2	1.45	15.0	381
5036.147	Pheasant	1272.0	54/19	1.382	36AH	3.1	1.41	15.0	381
5036.147	Dipper	1351.5	45/7	1.386	36AH	3.1	1.41	15.0	381
5038.150	Martin	1351.5	54/19	1.424	38AH	4.0	1.81	16.0	406
5038.150	Bobolink	1431.0	45/7	1.427	38AH	4.0	1.81	16.0	406
5038.156	Plover	1431.0	54/19	1.465	38AH	3.8	1.72	16.0	406
5038.156	Nuthatch	1510.5	45/7	1.466	38AH	3.8	1.72	16.0	406

Jumper Connectors—5000 Series for ACSR Conductors (cont.)

JUMPER CONNECTOR CATALOG NUMBER	CODE NAME	CONDUCTOR			DIE SIZE	TOTAL WEIGHT		DIMENSION L	
		SIZE	STRANDING	DIA.	ALUMINUM HEX DIES	LBS	KG	IN	MM
		KCMIL	AL/ST	IN					
5040.162	Parrot	1510.5	54/19	1.506	40AH	4.5	2.04	17.0	432
5040.162	Lapwing	1590.0	45/7	1.504	40AH	4.5	2.04	17.0	432
5040.162	Falcon	1590.0	54/19	1.545	40AH	4.5	2.04	17.0	432
5042.178	Chukar	1780.0	84/19	1.602	42AH	4.6	2.09	17.0	432
5042.178	—	2034.0	72/7	1.681	42AH	4.6	2.09	17.0	432
5044.184	Bluebird	2156.0	84/19	1.762	44AH	5.4	2.45	17.0	432
5044.181	Kiwi	2167.0	72/7	1.737	44AH	5.4	2.45	17.0	432
5044.188	Thrasher	2312.0	76/19	1.802	44AH	5.0	2.27	17.0	432
5048.197	Joree	2515.0	76/19	1.880	48AH	7.3	3.31	19.0	483

Terminal Connectors—5600 Series for ACSR Conductors, Straight

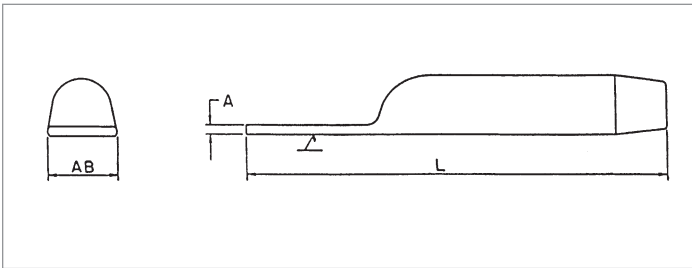

The 5600 Series Straight Terminal Connector is designed for ACSR conductors. The terminal connector is fabricated from AFL seamless drawn aluminum.

When used with the dead end, the straight terminal connector allows drop at a 15° angle. All terminal connectors are designed for limited tension use, maintaining a minimum of 40% of the ASTM rated strength of the conductor on which it is being used.

Ordering Instructions

Step 1: Assembly Catalog Number

Determine the assembly catalog number based on the conductor being used.

Step 2: Extra High Voltage Finish

For Extra High Voltage Finish, use 'EHV'.
For Standard Finish, leave blank.

Step 3: Assemble Catalog Number.

Assy Catalog Number + **EHV Finish**

Example:

For 795 Drake conductor with an EHV finish, the complete catalog number is:

5630.116EHV

TERMINAL CATALOG NUMBER	CONDUCTOR				DIE SIZE	TOTAL WEIGHT		DIMENSION						PAD SIZE
	CODE WORD	SIZE	STRANDING	DIA.				ALUMINUM HEX DIE	L		A		AB	
		KCMIL	AL/ST	IN	LBS	KG	IN		MM	IN	MM	IN	MM	
5674.438	Raven	1/0	6/1	0.398	74AH	0.3	0.14	8.3	211	0.3	9	1.0	25	B
5674.484	Quail	2/0	6/1	0.447	74AH	0.3	0.12	8.3	211	0.3	8	1.0	25	B
5675.547	Pigeon	3/0	6/1	0.502	75AH	0.5	0.23	9.5	241	0.5	13	1.0	25	B
5675.609	Penguin	4/0	6/1	0.563	75AH	0.5	0.20	9.8	248	0.5	12	1.0	25	B
5676.656	Waxwing	266.8	18/1	0.609	76AH	0.8	0.38	10.4	265	0.6	15	1.3	32	B
5676.688	Owl	266.8	6/7	0.633	76AH	0.8	0.37	10.6	268	0.6	14	1.3	32	B
5676.688	Partridge	266.8	26/7	0.642	76AH	0.8	0.37	10.6	268	0.6	14	1.3	32	B
5676.719	Ostrich	300.0	26/7	0.680	76AH	0.8	0.36	10.7	272	0.5	13	1.3	32	B
5676.719	Merlin	336.4	18/1	0.684	76AH	0.8	0.36	10.7	272	0.5	13	1.3	32	B
5676.781	Linnet	336.4	26/7	0.720	76AH	0.7	0.33	10.9	278	0.5	12	1.3	32	B
5676.781	Chickadee	397.5	18/1	0.743	76AH	0.7	0.33	10.9	278	0.5	12	1.3	32	B
5620.781	Linnet	336.4	26/7	0.720	20AH	0.8	0.38	11.6	295	0.5	12	1.3	32	B
5620.781	Oriole	336.4	30/7	0.741	20AH	0.8	0.38	11.6	295	0.5	12	1.3	32	B
5620.781	Chickadee	397.5	18/1	0.743	20AH	0.8	0.38	11.6	295	0.5	12	1.3	32	B

Notes:

1. Pad Dimensions are on page 117.
2. AFL Filler Compound (AFC) Requirements are on page 117.
3. Installation Instructions for Terminals are on page 131.
4. Bolts, nuts and washers are not supplied with the straight terminal connector.

Terminal Connectors—5600 Series for ACSR Conductors, Straight (cont.)

TERMINAL CATALOG NUMBER	CODE WORD	CONDUCTOR			DIE SIZE	TOTAL WEIGHT		DIMENSION						PAD SIZE
		SIZE	STRANDING	DIA.	ALUMINUM HEX DIE			L		A		AB		
		KCMIL	AL/ST	IN		IN	MM	IN	MM	IN	MM			
5620.812	Brant	397.5	24/7	0.772	20AH	0.8	0.37	12.3	306	0.5	12	1.3	32	B
5620.844	Ibis	397.5	26/7	0.783	20AH	0.8	0.37	12.5	318	0.5	12	1.3	32	B
5620.844	Lark	397.5	30/7	0.806	20AH	0.8	0.37	12.5	318	0.5	12	1.3	32	B
5624.875	Pelican	477.0	18/1	0.814	24AH	1.4	0.64	12.6	319	0.6	16	1.5	38	B
5624.938	Flicker	477.0	24/7	0.846	24AH	1.3	0.59	12.8	324	0.6	15	1.5	38	B
5624.938	Hawk	477.0	26/7	0.858	24AH	1.3	0.59	12.8	324	0.6	15	1.5	38	B
5624.938	Hen	477.0	30/7	0.883	24AH	1.3	0.59	12.8	324	0.6	15	1.5	38	B
5624.938	Osprey	556.5	18/1	0.879	24AH	1.3	0.59	12.8	324	0.6	15	1.5	38	B
5624.969	Parakeet	556.5	24/7	0.914	24AH	1.3	0.59	12.8	325	0.6	15	1.5	38	B
5624.969	Dove	556.5	26/7	0.927	24AH	1.3	0.59	12.8	325	0.6	15	1.5	38	B
5627.100	Eagle	556.5	30/7	0.953	27AH	1.7	0.77	13.1	333	0.4	10	3.0	76	D
5627.100	Peacock	605.0	24/7	0.953	27AH	1.7	0.77	13.1	333	0.4	10	3.0	76	D
5627.100	Squab	605.0	26/7	0.966	27AH	1.7	0.77	13.1	333	0.4	10	3.0	76	D
5627.100	Swift	636.0	36/1	0.930	27AH	1.7	0.77	13.1	333	0.4	10	3.0	76	D
5627.100	Kingbird	636.0	18/1	0.940	27AH	1.7	0.77	13.1	333	0.4	10	3.0	76	D
5627.106	Teal	605.0	30/19	0.994	27AH	1.7	0.77	13.1	333	0.4	10	3.0	76	D
5627.106	Rook	636.0	24/7	0.977	27AH	1.7	0.77	13.1	333	0.4	10	3.0	76	D
5627.106	Grosbeak	636.0	26/7	0.990	27AH	1.7	0.77	13.1	333	0.4	10	3.0	76	D
5627.106	Egret	636.0	30/19	1.019	27AH	1.7	0.77	13.1	333	0.4	10	3.0	76	D
5627.106	Flamingo	666.6	24/7	1.000	27AH	1.7	0.77	13.1	333	0.4	10	3.0	76	D
5630.109	Stilt	715.5	24/7	1.036	30AH	2.4	1.09	14.3	363	0.5	13	3.0	76	D
5630.109	Starling	715.5	26/7	1.051	30AH	2.4	1.09	14.3	363	0.5	13	3.0	76	D
5630.109	Coot	795.0	36/1	1.040	30AH	2.4	1.09	14.3	363	0.5	13	3.0	76	D
5630.116	Redwing	715.5	30/19	1.081	30AH	2.3	1.04	14.6	370	0.5	12	3.0	76	D
5630.116	Tern	795.0	45/7	1.063	30AH	2.3	1.04	14.6	370	0.5	12	3.0	76	D
5630.116	Condor	795.0	54/7	1.093	30AH	2.3	1.04	14.6	370	0.5	12	3.0	76	D
5630.116	Drake	795.0	26/7	1.108	30AH	2.3	1.04	14.6	370	0.5	12	3.0	76	D
5630.116	Cuckoo	795.0	24/7	1.092	30AH	2.3	1.04	14.6	370	0.5	12	3.0	76	D
5630.122	Mallard	795.0	30/19	1.140	30AH	2.2	1.00	14.9	378	0.4	10	3.0	76	D
5630.122	Ruddy	900.0	45/7	1.131	30AH	2.2	1.00	14.9	378	0.4	10	3.0	76	D
5630.122	Canary	900.0	54/7	1.162	30AH	2.2	1.00	14.9	378	0.4	10	3.0	76	D
5630.122	Catbird	954.0	36/1	1.140	30AH	2.2	1.00	14.9	378	0.4	10	3.0	76	D
5630.122	Rail	954.0	45/7	1.165	30AH	2.2	1.00	14.9	378	0.4	10	3.0	76	D
5630.125	Cardinal	954.0	54/7	1.196	30AH	2.2	1.00	14.9	378	0.4	10	3.0	76	D
5630.125	Tanager	1033.5	36/1	1.186	30AH	2.2	1.00	14.9	378	0.4	10	3.0	76	D
5634.128	Ortolan	1033.5	45/7	1.212	34AH	3.3	1.50	15.3	389	0.6	16	3.0	76	D

Terminal Connectors—5600 Series for ACSR Conductors, Straight (cont.)

TERMINAL CATALOG NUMBER	CODE WORD	CONDUCTOR			DIE SIZE	TOTAL WEIGHT		DIMENSION						PAD SIZE
		SIZE	STRANDING	DIA.	ALUMINUM HEX DIE			L		A		AB		
		KCMIL	AL/ST	IN		IN	MM	IN	MM	IN	MM			
5634.134	Curlew	1033.5	54/7	1.244	34AH	3.2	1.45	15.8	400	0.6	15	3.0	76	D
5634.134	Bluejay	1113.0	45/7	1.259	34AH	3.2	1.45	15.8	400	0.6	15	3.0	76	D
5634.138	Bunting	1192.5	45/7	1.302	34AH	3.2	1.45	16.0	406	0.6	15	3.0	76	D
5634.138	Finch	1113.0	54/19	1.293	34AH	3.2	1.45	16.0	406	0.6	15	3.0	76	D
5636.144	Bittern	1272.0	45/7	1.345	36AH	3.6	1.63	16.6	421	0.6	15	3.0	76	D
5636.144	Grackle	1192.5	54/19	1.333	36AH	3.6	1.63	16.6	421	0.6	15	3.0	76	D
5636.147	Pheasant	1272.0	54/19	1.382	36AH	3.5	1.59	16.1	409	0.6	16	3.0	76	D
5636.147	Dipper	1351.5	45/7	1.386	36AH	3.5	1.59	16.1	409	0.6	16	3.0	76	D
5638.150	Martin	1351.5	54/19	1.424	38AH	4.4	2.00	17.1	435	0.8	20	3.0	76	D
5638.150	Bobolink	1431.0	45/7	1.427	38AH	4.4	2.00	17.1	435	0.8	20	3.0	76	D
5638.156	Plover	1431.0	54/19	1.465	38AH	4.2	1.91	17.9	454	0.7	17	3.0	76	D
5638.156	Nuthatch	1510.5	45/7	1.466	38AH	4.2	1.91	17.9	454	0.7	17	3.0	76	D
5640.162	Parrot	1510.5	54/19	1.506	40AH	4.8	2.18	17.6	446	0.7	17	3.0	76	D
5640.162	Lapwing	1590.0	45/7	1.504	40AH	4.8	2.18	17.6	446	0.7	17	3.0	76	D
5640.162	Falcon	1590.0	54/19	1.545	40AH	4.8	2.18	17.6	446	0.7	17	3.0	76	D
5642.178	Chukar	1780.0	84/19	1.602	42AH	5.3	2.40	19.0	483	0.7	17	4.0	102	E
5642.178	—	2034.0	72/7	1.681	42AH	5.3	2.40	19.0	483	0.7	17	4.0	102	E
5644.184	Bluebird	2156.0	84/19	1.762	44AH	6.2	2.81	19.6	497	0.7	18	4.0	102	E
5644.181	Kiwi	2167.0	72/7	1.737	44AH	6.3	2.86	19.5	493	0.7	18	4.0	102	E
5644.188	Thrasher	2312.0	76/19	1.802	44AH	6.1	2.77	19.6	498	0.7	18	4.0	102	E
5648.197	Joree	2515.0	76/19	1.880	48AH	8.2	3.72	21.6	549	0.8	21	4.0	102	E

Terminal Connectors—5100 Series for ACSR Conductors, 15°

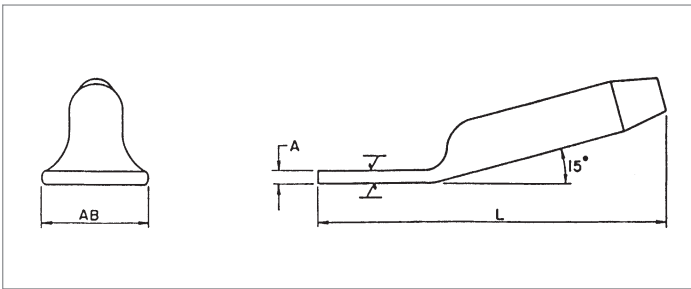

The 5100 Series 15° Terminal Connector is designed for ACSR conductors. The terminal connector is fabricated from AFL seamless drawn aluminum.

When used with the dead end, the 15° terminal connector can be bolted in either the straight or 30° position. All terminal connectors are designed for limited tension use, maintaining a minimum of 40% of the ASTM rated strength of the conductor on which it is being used. Aluminum hardware is supplied with the 15° terminal connector.

Ordering Instructions

Step 1: Assembly Catalog Number

Determine the assembly catalog number based on the conductor being used.

Step 2: Extra High Voltage Finish

For Extra High Voltage Finish, use 'EHV'.
For Standard Finish, leave blank.

Step 3: Assemble Catalog Number.

Assy Catalog Number + **EHV Finish**

Example:

For 795 Drake conductor with an EHV finish, the complete catalog number is:

5130.116EHV

TERMINAL CATALOG NUMBER	CONDUCTOR				DIE SIZE ALUMINUM HEX DIE	TOTAL WEIGHT		DIMENSION						PAD SIZE
	CODE WORD	SIZE	STRAND-ING	DIA.				L		A		AB		
		KCMIL	AL/ST	IN	LBS	KG	IN	MM	IN	MM	IN	MM		
5174.438	Grouse	80.0	6/1	0.367	74AH	0.4	0.20	8.3	211	0.3	9	1.0	25	B
5174.438	Raven	1/0	6/1	0.398	74AH	0.4	0.20	8.3	211	0.3	9	1.0	25	B
5174.484	Quail	2/0	6/1	0.447	74AH	0.4	0.19	8.3	211	0.3	8	1.0	25	B
5175.547	Pigeon	3/0	6/1	0.502	75AH	0.7	0.29	9.5	241	0.5	13	1.0	25	B
5175.609	Penguin	4/0	6/1	0.563	75AH	0.6	0.27	9.8	248	0.5	12	1.0	25	B
5176.656	Waxwing	266.8	18/1	0.609	76AH	0.9	0.41	10.4	265	0.6	15	1.3	32	B
5176.688	Owl	266.8	6/7	0.633	76AH	0.9	0.40	10.6	268	0.6	14	1.3	32	B
5176.688	Partridge	266.8	26/7	0.642	76AH	0.9	0.40	10.6	268	0.6	14	1.3	32	B
5176.719	Ostrich	300.0	26/7	0.680	76AH	0.9	0.39	10.7	272	0.5	13	1.3	32	B
5176.719	Merlin	336.4	18/1	0.684	76AH	0.9	0.39	10.7	272	0.5	13	1.3	32	B
5176.781	Linnet	336.4	26/7	0.720	76AH	0.8	0.37	10.9	276	0.5	12	1.3	32	B
5176.781	Chickadee	397.5	18/1	0.743	76AH	0.8	0.37	10.9	276	0.5	12	1.3	32	B

Notes:

1. Pad Dimensions are on page 117.
2. AFL Filler Compound (AFC) Requirements are on page 115.
3. Installation Instructions for Terminals are on page 131.
4. Supplied with aluminum hardware.

Terminal Connectors—5100 Series for ACSR Conductors, 15° (cont.)

TERMINAL CATALOG NUMBER	CONDUCTOR				DIE SIZE	TOTAL WEIGHT		DIMENSION						PAD SIZE
	CODE WORD	SIZE	STRAND-ING	DIA.	ALUMINUM HEX DIE			L		A		AB		
		KCMIL	AL/ST	IN		LBS	KG	IN	MM	IN	MM	IN	MM	
5120.781	Linnet	336.4	26/7	0.720	20AH	1.0	0.45	11.6	295	0.5	12	1.3	32	B
5120.781	Oriole	336.4	30/7	0.741	20AH	1.0	0.45	11.6	295	0.5	12	1.3	32	B
5120.781	Chickadee	397.5	18/1	0.743	20AH	1.0	0.45	11.6	295	0.5	12	1.3	32	B
5120.812	Brant	397.5	24/7	0.772	20AH	1.0	0.44	12.1	306	0.5	12	1.3	32	B
5120.844	Ibis	397.5	26/7	0.783	20AH	1.0	0.44	12.5	318	0.5	12	1.3	32	B
5120.844	Lark	397.5	30/7	0.806	20AH	1.0	0.44	12.5	318	0.5	12	1.3	32	B
5124.875	Pelican	477.0	18/1	0.814	24AH	1.6	0.73	12.6	319	0.6	16	1.5	38	B
5124.938	Flicker	477.0	24/7	0.846	24AH	1.5	0.68	12.8	324	0.6	15	1.5	38	B
5124.938	Hawk	477.0	26/7	0.858	24AH	1.5	0.68	12.8	324	0.6	15	1.5	38	B
5124.938	Hen	477.0	30/7	0.883	24AH	1.5	0.68	12.8	324	0.6	15	1.5	38	B
5124.938	Osprey	556.5	18/1	0.879	24AH	1.5	0.68	12.8	324	0.6	15	1.5	38	B
5124.969	Parakeet	556.5	24/7	0.914	24AH	1.5	0.68	12.8	325	0.6	15	1.5	38	B
5124.969	Dove	556.5	26/7	0.927	24AH	1.5	0.68	12.8	325	0.6	15	1.5	38	B
5127.100	Eagle	556.5	30/7	0.953	27AH	1.9	0.86	12.3	313	0.4	10	3.0	76	D
5127.100	Peacock	605.0	24/7	0.953	27AH	1.9	0.86	12.3	313	0.4	10	3.0	76	D
5127.100	Squab	605.0	26/7	0.966	27AH	1.9	0.86	12.3	313	0.4	10	3.0	76	D
5127.106	Teal	605.0	30/19	0.994	27AH	1.9	0.86	12.3	313	0.4	10	3.0	76	D
5127.100	Swift	636.0	36/1	0.930	27AH	1.9	0.86	12.3	313	0.4	10	3.0	76	D
5127.100	Kingbird	636.0	18/1	0.940	27AH	1.9	0.86	12.3	313	0.4	10	3.0	76	D
5127.106	Rook	636.0	24/7	0.977	27AH	1.9	0.86	12.3	313	0.4	10	3.0	76	D
5127.106	Grosbeak	636.0	26/7	0.990	27AH	1.9	0.86	12.3	313	0.4	10	3.0	76	D
5127.106	Egret	636.0	30/19	1.019	27AH	1.9	0.86	12.3	313	0.4	10	3.0	76	D
5127.106	Flamingo	666.6	24/7	1.000	27AH	1.9	0.86	12.3	313	0.4	10	3.0	76	D
5130.109	Stilt	715.5	24/7	1.036	30AH	2.7	1.22	13.6	346	0.5	13	3.0	76	D
5130.109	Starling	715.5	26/7	1.051	30AH	2.7	1.22	13.6	346	0.5	13	3.0	76	D
5130.109	Coot	795.0	36/1	1.040	30AH	2.7	1.22	13.6	346	0.5	13	3.0	76	D
5130.116	Redwing	715.5	30/19	1.081	30AH	2.6	1.18	13.9	354	0.5	12	3.0	76	D
5130.116	Tern	795.0	45/7	1.063	30AH	2.6	1.18	13.9	354	0.5	12	3.0	76	D
5130.116	Condor	795.0	54/7	1.093	30AH	2.6	1.18	13.9	354	0.5	12	3.0	76	D
5130.116	Drake	795.0	26/7	1.108	30AH	2.6	1.18	13.9	354	0.5	12	3.0	76	D
5130.116	Cuckoo	795.0	24/7	1.092	30AH	2.6	1.18	13.9	354	0.5	12	3.0	76	D
5130.122	Mallard	795.0	30/19	1.140	30AH	2.5	1.13	14.3	362	0.4	10	3.0	76	D
5130.122	Ruddy	900.0	45/7	1.131	30AH	2.5	1.13	14.3	362	0.4	10	3.0	76	D
5130.122	Canary	900.0	54/7	1.162	30AH	2.5	1.13	14.3	362	0.4	10	3.0	76	D
5130.122	Catbird	954.0	36/1	1.140	30AH	2.5	1.13	14.3	362	0.4	10	3.0	76	D
5130.122	Rail	954.0	45/7	1.165	30AH	2.5	1.13	14.3	362	0.4	10	3.0	76	D

Terminal Connectors—5100 Series for ACSR Conductors, 15° (cont.)

TERMINAL CATALOG NUMBER	CONDUCTOR				DIE SIZE	TOTAL WEIGHT		DIMENSION						PAD SIZE
	CODE WORD	SIZE	STRAND-ING	DIA.	ALUMINUM HEX DIE			L		A		AB		
		KCMIL	AL/ST	IN		LBS	KG	IN	MM	IN	MM	IN	MM	
5130.125	Cardinal	954.0	54/7	1.196	30AH	2.5	1.13	14.4	367	0.4	10	3.0	76	D
5130.125	Tanager	1033.5	36/1	1.186	30AH	2.5	1.13	14.4	367	0.4	10	3.0	76	D
5134.128	Ortolan	1033.5	45/7	1.212	34AH	3.6	1.63	14.3	363	0.6	16	3.0	76	D
5134.134	Curlew	1033.5	54/7	1.244	34AH	3.5	1.59	14.5	368	0.6	15	3.0	76	D
5134.134	Bluejay	1113.0	45/7	1.259	34AH	3.5	1.59	14.5	368	0.6	15	3.0	76	D
5134.138	Finch	1113.0	54/19	1.293	34AH	3.4	1.54	14.6	370	0.6	15	3.0	76	D
5134.138	Bunting	1192.5	45/7	1.302	34AH	3.4	1.54	14.6	370	0.6	15	3.0	76	D
5136.144	Grackle	1192.5	54/19	1.333	36AH	3.8	1.72	15.3	389	0.6	15	3.0	76	D
5136.144	Bittern	1272.0	45/7	1.345	36AH	3.8	1.72	15.3	389	0.6	15	3.0	76	D
5136.147	Pheasant	1272.0	54/19	1.382	36AH	3.8	1.72	15.1	384	0.6	16	3.0	76	D
5136.147	Dipper	1351.5	45/7	1.386	36AH	3.8	1.72	15.1	384	0.6	16	3.0	76	D
5138.150	Martin	1351.5	54/19	1.424	38AH	4.5	2.04	15.8	400	0.8	20	3.0	76	D
5138.150	Bobolink	1431.0	45/7	1.427	38AH	4.5	2.04	15.8	400	0.8	20	3.0	76	D
5138.156	Plover	1431.0	54/19	1.465	38AH	4.4	2.00	16.7	424	0.9	17	3.0	76	D
5138.156	Nuthatch	1510.5	45/7	1.466	38AH	4.4	2.00	16.7	424	0.9	17	3.0	76	D
5140.162	Parrot	1510.5	54/19	1.506	40AH	5.3	2.40	17.4	443	0.7	18	4.0	102	E
5140.162	Lapwing	1590.0	45/7	1.504	40AH	5.3	2.40	17.4	443	0.7	18	4.0	102	E
5140.162	Falcon	1590.0	54/19	1.545	40AH	5.3	2.40	17.4	443	0.7	18	4.0	102	E
5142.178	Chukar	1780.0	84/19	1.602	42AH	5.7	2.59	18.5	470	0.7	17	4.0	102	E
5142.178	—	2034.0	72/7	1.681	42AH	5.7	2.59	18.5	470	0.7	17	4.0	102	E
5144.184	Bluebird	2156.0	84/19	1.762	44AH	6.7	3.04	18.6	471	0.7	18	4.0	102	E
5144.181	Kiwi	2167.0	72/7	1.737	44AH	6.7	3.04	18.6	471	0.7	18	4.0	102	E
5144.188	Thrasher	2312.0	76/19	1.802	44AH	6.6	2.99	18.6	473	0.7	18	4.0	102	E
5148.197	Joree	2515.0	76/19	1.880	48AH	8.7	3.95	20.3	514	0.8	21	4.0	102	E

Terminal Connectors—5800 Series for ACSR Conductors, 90°

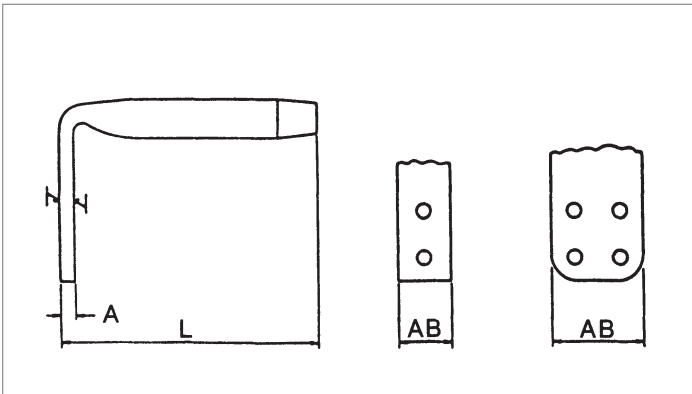

The 5800 Series 90° Terminal Connector is designed for ACSR conductors. The terminal connector is fabricated from AFL seamless drawn aluminum.

All terminal connectors are designed for limited tension use, maintaining a minimum of 40% of the ASTM rated strength of the conductor on which it is being used.

Ordering Instructions

Step 1: Assembly Catalog Number

Determine the assembly catalog number based on the conductor being used.

Step 2: Extra High Voltage Finish

For Extra High Voltage Finish, use 'EHV'.
For Standard Finish, leave blank.

Step 3: Assemble Catalog Number.

Assy Catalog Number + **EHV Finish**

Example:

For 795 Drake conductor with an EHV finish, the complete catalog number is:

5830.116EHV

TERMINAL CATALOG NUMBER	CODE WORD	CONDUCTOR			DIE SIZE	TOTAL WEIGHT		DIMENSION						PAD SIZE
		SIZE	STRANDING	DIA.	ALUMINUM HEX DIE			L		A		AB		
		KCMIL	AL/ST	IN		LBS	KG	IN	MM	IN	MM	IN	MM	
5874.438	Grouse	80.0	8/1	0.367	74AH	0.3	0.15	4.9	124	0.3	9	1.0	25	B
5874.438	Raven	1/0	6/1	0.398	74AH	0.3	0.15	4.9	124	0.3	9	1.0	25	B
5874.484	Quail	2/0	6/1	0.447	74AH	0.3	0.15	4.9	124	0.3	9	1.0	25	B
5875.547	Pigeon	3/0	6/1	0.502	75AH	0.5	0.24	6.0	152	0.5	13	1.0	25	B
5875.609	Penguin	4/0	6/1	0.563	75AH	0.5	0.22	6.3	159	0.5	12	1.0	25	B
5876.656	Waxwing	266.8	18/1	0.609	76AH	0.8	0.38	7.1	181	0.6	15	1.3	32	B
5876.688	Owl	266.8	6/7	0.633	76AH	0.8	0.37	7.3	184	0.6	14	1.3	32	B
5876.688	Partridge	266.8	26/7	0.642	76AH	0.8	0.37	7.3	184	0.6	14	1.3	32	B

Notes:

1. Pad Dimensions are on page 117.
2. AFL Filler Compound (AFC) Requirements are on page 115.
3. Installation Instructions for Terminals are on page 131.
4. Bolts, nuts and washers are not supplied with the 90° terminal connector.

Terminal Connectors—5800 Series for ACSR Conductors, 90° (cont.)

TERMINAL CATALOG NUMBER	CODE WORD	CONDUCTOR			DIE SIZE	TOTAL WEIGHT		DIMENSION						PAD SIZE
		SIZE	STRANDING	DIA.	ALUMINUM HEX DIE			L		A		AB		
		KCMIL	AL/ST	IN		LBS	KG	IN	MM	IN	MM	IN	MM	
5876.719	Ostrich	300.0	26/7	0.680	76AH	0.8	0.36	7.3	184	0.5	13	1.3	32	B
5876.719	Merlin	336.4	18/1	0.684	76AH	0.8	0.36	7.3	184	0.5	13	1.3	32	B
5876.781	Linnet	336.4	26/7	0.720	76AH	0.7	0.33	7.6	194	0.5	12	1.3	32	B
5876.781	Chickadee	397.5	18/1	0.743	76AH	0.7	0.33	7.6	194	0.5	12	1.3	32	B
5820.781	Linnet	336.4	26/7	0.720	20AH	0.9	0.40	8.5	216	0.5	12	1.3	32	B
5820.781	Oriole	336.4	30/7	0.741	20AH	0.9	0.40	8.5	216	0.5	12	1.3	32	B
5820.781	Chickadee	397.5	18/1	0.743	20AH	0.9	0.40	8.5	216	0.5	12	1.3	32	B
5820.812	Brant	397.5	24/7	0.772	20AH	0.9	0.39	8.9	226	0.5	12	1.3	32	B
5820.844	Ibis	397.5	26/7	0.783	20AH	0.9	0.40	9.1	232	0.5	12	1.3	32	B
5820.844	Lark	397.5	30/7	0.806	20AH	0.9	0.40	9.1	232	0.5	12	1.3	32	B
5824.875	Pelican	477.0	18/1	0.814	24AH	1.5	0.68	9.4	238	0.6	16	1.5	38	B
5824.938	Flicker	477.0	24/7	0.846	24AH	1.4	0.64	9.5	241	0.6	15	1.5	38	B
5824.938	Hawk	477.0	26/7	0.858	24AH	1.4	0.64	9.5	241	0.6	15	1.5	38	B
5824.938	Hen	477.0	30/7	0.883	24AH	1.4	0.64	9.5	241	0.6	15	1.5	38	B
5824.938	Osprey	556.5	18/1	0.879	24AH	1.4	0.64	9.5	241	0.6	15	1.5	38	B
5824.969	Parakeet	556.5	24/7	0.914	24AH	1.4	0.64	9.5	241	0.6	15	1.5	38	B
5824.969	Dove	556.5	26/7	0.927	24AH	1.4	0.64	9.5	241	0.6	15	1.5	38	B
5827.100	Eagle	556.5	30/7	0.953	27AH	1.7	0.77	8.9	226	0.4	10	3.0	76	D
5827.100	Peacock	605.0	24/7	0.953	27AH	1.7	0.77	8.9	226	0.4	10	3.0	76	D
5827.100	Squab	605.0	26/7	0.966	27AH	1.7	0.77	8.9	226	0.4	10	3.0	76	D
5827.100	Swift	636.0	36/1	0.930	27AH	1.7	0.77	8.9	226	0.4	10	3.0	76	D
5827.100	Kingbird	636.0	18/1	0.940	27AH	1.7	0.77	8.9	226	0.4	10	3.0	76	D
5827.106	Teal	605.0	30/19	0.994	27AH	1.7	0.77	8.9	226	0.4	10	3.0	76	D
5827.106	Rook	636.0	24/7	0.977	27AH	1.7	0.77	8.9	226	0.4	10	3.0	76	D
5827.106	Grosbeak	636.0	26/7	0.990	27AH	1.7	0.77	8.9	226	0.4	10	3.0	76	D
5827.106	Egret	636.0	30/19	1.019	27AH	1.7	0.77	8.9	226	0.4	10	3.0	76	D
5827.106	Flamingo	666.6	24/7	1.000	27AH	1.7	0.77	8.9	226	0.4	10	3.0	76	D
5830.109	Stilt	715.5	24/7	1.036	30AH	2.4	1.09	10.3	260	0.5	13	3.0	76	D
5830.109	Starling	715.5	26/7	1.051	30AH	2.4	1.09	10.3	260	0.5	13	3.0	76	D
5830.109	Coot	795.0	36/1	1.040	30AH	2.4	1.09	10.3	260	0.5	13	3.0	76	D
5830.116	Redwing	715.5	30/19	1.081	30AH	2.3	1.04	10.5	267	0.5	12	3.0	76	D
5830.116	Tern	795.0	45/7	1.063	30AH	2.3	1.04	10.5	267	0.5	12	3.0	76	D
5830.116	Condor	795.0	54/7	1.093	30AH	2.3	1.04	10.5	267	0.5	12	3.0	76	D
5830.116	Drake	795.0	26/7	1.108	30AH	2.3	1.04	10.5	267	0.5	12	3.0	76	D
5830.116	Cuckoo	795.0	24/7	1.092	30AH	2.3	1.04	10.5	267	0.5	12	3.0	76	D
5830.122	Mallard	795.0	30/19	1.140	30AH	2.2	1.00	10.8	273	0.4	10	3.0	76	D

Terminal Connectors—5800 Series for ACSR Conductors, 90° (cont.)

TERMINAL CATALOG NUMBER	CODE WORD	CONDUCTOR			DIE SIZE	TOTAL WEIGHT		DIMENSION						PAD SIZE
		SIZE	STRANDING	DIA.	ALUMINUM HEX DIE			L		A		AB		
		KCMIL	AL/ST	IN		IN	MM	IN	MM	IN	MM			
5830.122	Ruddy	900.0	45/7	1.131	30AH	2.2	1.00	10.8	273	0.4	10	3.0	76	D
5830.122	Canary	900.0	54/7	1.162	30AH	2.2	1.00	10.8	273	0.4	10	3.0	76	D
5830.122	Catbird	954.0	36/1	1.140	30AH	2.2	1.00	10.8	273	0.4	10	3.0	76	D
5830.122	Rail	954.0	45/7	1.165	30AH	2.2	1.00	10.8	273	0.4	10	3.0	76	D
5830.125	Cardinal	954.0	54/7	1.196	30AH	2.2	1.00	10.9	276	0.4	10	3.0	76	D
5830.125	Tanager	1033.5	36/1	1.186	30AH	2.2	1.00	10.9	276	0.4	10	3.0	76	D
5834.128	Ortolan	1033.5	45/7	1.212	34AH	3.3	1.50	11.5	292	0.6	16	3.0	76	D
5834.134	Curlew	1033.5	54/7	1.244	34AH	3.2	1.45	11.5	292	0.6	15	3.0	76	D
5834.134	Bluejay	1113.0	45/7	1.259	34AH	3.2	1.45	11.5	292	0.6	15	3.0	76	D
5834.138	Finch	1113.0	54/19	1.293	34AH	3.1	1.41	11.5	292	0.6	15	3.0	76	D
5834.138	Bunting	1192.5	45/7	1.302	34AH	3.1	1.41	11.5	292	0.6	15	3.0	76	D
5936.144	Crackle	1192.5	54/19	1.333	36AH	3.5	1.6	12.1	308	0.6	15	3.0	76	D
5836.144	Bittern	1272.0	45/7	1.345	36AH	3.5	1.59	12.1	308	0.6	15	3.0	76	D
5836.147	Pheasant	1272.0	54/19	1.382	36AH	3.5	1.59	12.1	308	0.6	16	3.0	76	D
5836.147	Dipper	1351.5	45/7	1.386	36AH	3.5	1.59	12.1	308	0.6	16	3.0	76	D
5838.150	Martin	1351.5	54/19	1.424	38AH	4.2	1.91	12.6	321	0.8	20	3.0	76	D
5838.150	Bobolink	1431.0	45/7	1.427	38AH	4.2	1.91	12.6	321	0.8	20	3.0	76	D
5838.156	Plover	1431.0	54/19	1.465	38AH	4.2	1.91	13.6	346	0.7	17	3.0	76	D
5838.156	Nuthatch	1510.5	45/7	1.466	38AH	4.2	1.91	13.6	346	0.7	17	3.0	76	D
5840.162	Parrot	1510.5	54/19	1.506	40AH	4.7	2.13	13.3	338	0.7	17	3.0	76	D
5840.162	Lapwing	1590.0	45/7	1.504	40AH	4.7	2.13	13.3	338	0.7	17	3.0	76	D
5840.162	Falcon	1590.0	54/19	1.545	40AH	4.7	2.13	13.3	338	0.7	17	3.0	76	D
5842.178	Chukar	1780.0	84/19	1.602	42AH	5.5	2.49	14.5	368	0.7	17	4.0	102	E
5842.178	—	2034.0	72/7	1.681	42AH	5.5	2.49	14.5	368	0.7	17	4.0	102	E
5844.181	Kiwi	2167.0	72/7	1.737	44AH	6.7	3.04	14.6	371	0.7	18	4.0	102	E
5844.184	Bluebird	2156.0	84/19	1.762	44AH	6.6	2.99	14.8	375	0.7	18	4.0	102	E
5844.188	Thrasher	2312.0	76/19	1.802	44AH	6.6	2.99	15.1	384	0.7	18	4.0	102	E
5848.197	Joree	2515.0	76/19	1.880	48AH	8.5	3.86	16.4	416	0.8	21	4.0	102	E

Tee Connector—5500 Series for ACSR Conductors, Open Run

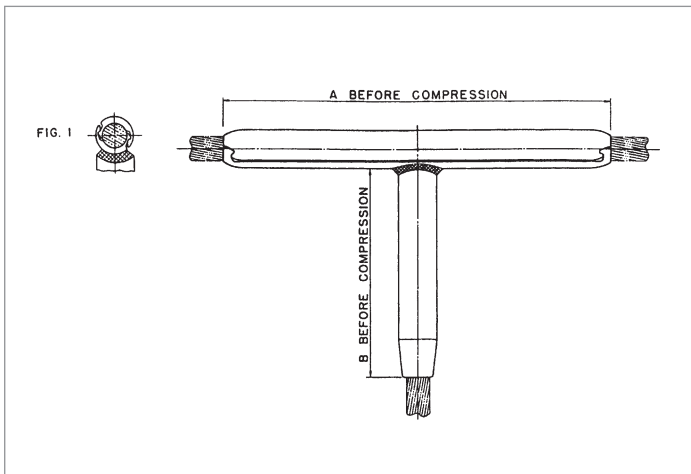

The 5500 Series Tee Connector is a permanent drop designed for ACSR conductors. The tee connector is fabricated from AFL seamless drawn aluminum.

The run portion incorporates an improved design of interlocking extrusions, providing a permanent grip on the conductor when compressed.

The branch portion of the tee connector is designed for limited tension use, maintaining a minimum of 40% of the ASTM rated strength of the conductor on which it is being used.

For die size sections 30AH and above, the end tapers of the compression portions of all compression accessories are supplied with a high voltage finish.

Ordering Instructions

Step 1: Determine Run Catalog Number

Determine the run catalog number based on the conductor being used.

Step 2: Determine Branch Catalog Number

Determine the branch catalog number based on the conductor being used.

Step 3: Assemble Catalog Number



Example:

For 795 Drake Conductor in both Run and Branch, the complete catalog number is:

5530.3 – 30.116

Notes:

1. AFL Filler Compound (AFC) requirements are on page 115.
2. Installation Instructions for Open Run Tee Connectors are on page 144.

Tee Connector—5500 Series for ACSR Conductors, Open Run (cont.)

CODE WORD	CONDUCTOR			CATALOG NUMBER		DIE SIZE	WEIGHT				DIMENSIONS			
	SIZE	STRANDING	DIA.	RUN CONDUCTOR	BRANCH CONDUCTOR	ALUMINUM HEX DIE	RUN		BRANCH		A		B	
	KCMIL	AL/ST	IN				LBS	KG	LBS	KG	IN	MM	IN	MM
Raven	1/0	6/1	0.398	5574	74.438	74AH	0.2	0.10	0.2	0.09	7.6	192	5.5	140
Quail	2/0	6/1	0.447	5574	74.438	74AH	0.2	0.10	0.2	0.09	7.6	192	5.5	140
Pigeon	3/0	6/1	0.502	5575	75.547	75AH	0.4	0.18	0.3	0.14	8.6	217	6.0	152
Penguin	4/0	6/1	0.563	5575	75.609	75AH	0.4	0.18	0.3	0.14	8.6	217	6.0	152
Waxwing	266.8	18/1	0.609	5576	76.656	76AH	0.7	0.30	0.5	0.23	10.0	254	6.5	165
Owl	266.8	6/7	0.633	5576	76.688	76AH	0.7	0.30	0.5	0.23	10.0	254	6.5	165
Partridge	266.8	26/7	0.642	5576	76.688	76AH	0.7	0.30	0.5	0.23	10.0	254	6.5	165
Ostrich	300.0	26/7	0.680	5576	76.719	76AH	0.7	0.30	0.5	0.23	10.0	254	6.5	165
Merlin	336.4	18/1	0.684	5576	76.719	76AH	0.7	0.30	0.5	0.23	10.0	254	6.5	165
Linnet	336.4	26/7	0.720	5576	76.781	76AH	0.7	0.30	0.5	0.23	10.0	254	6.5	165
Chickadee	397.5	18/1	0.743	5576	76.781	76AH	0.7	0.30	0.5	0.23	10.0	254	6.5	165
Linnet	336.4	26/7	0.720	5520.3	20.781	20AH	1.0	0.45	0.6	0.27	14.5	368	7.6	194
Oriole	336.4	30/7	0.741	5520.3	20.781	20AH	1.0	0.45	0.6	0.27	14.5	368	7.6	194
Chickadee	397.5	18/1	0.743	5520.3	20.781	20AH	1.0	0.45	0.6	0.27	14.5	368	7.6	194
Brant	397.5	24/7	0.772	5520.3	20.812	20AH	1.0	0.45	0.6	0.27	14.5	368	7.6	194
Ibis	397.5	26/7	0.783	5520.3	20.844	20AH	1.0	0.45	0.6	0.27	14.5	368	7.6	194
Lark	397.5	30/7	0.806	5520.3	20.844	20AH	1.0	0.45	0.6	0.27	14.5	368	7.6	194
Pelican	477.0	18/1	0.814	5524.3	24.875	24AH	1.7	0.77	0.8	0.36	15.5	394	8.3	210
Flicker	477.0	24/7	0.846	5524.3	24.938	24AH	1.7	0.77	0.8	0.36	15.5	394	8.3	210
Hawk	477.0	26/7	0.858	5524.3	24.938	24AH	1.7	0.77	0.8	0.36	15.5	394	8.3	210
Hen	477.0	30/7	0.883	5524.3	24.938	24AH	1.7	0.77	0.8	0.36	15.5	394	8.3	210
Osprey	556.5	18/1	0.879	5524.3	24.938	24AH	1.7	0.77	0.8	0.36	15.5	394	8.3	210
Parakeet	556.5	24/7	0.914	5524.3	24.969	24AH	1.7	0.77	0.8	0.36	15.5	394	8.3	210
Dove	556.5	26/7	0.927	5524.3	24.969	24AH	1.7	0.77	0.8	0.36	15.5	394	8.3	210
Eagle	556.5	30/7	0.953	5527.3	27.100	27AH	2.7	1.22	1.3	0.59	18.3	464	8.8	225
Peacock	605.0	24/7	0.953	5527.3	27.100	27AH	2.7	1.22	1.3	0.59	18.3	464	8.8	225
Squab	605.0	26/7	0.966	5527.3	27.100	27AH	2.7	1.22	1.3	0.59	18.3	464	8.8	225
Teal	605.0	30/19	0.994	5527.3	27.106	27AH	2.7	1.22	1.3	0.59	18.3	464	8.8	225
Swift	636.0	36/1	0.930	5527.3	27.100	27AH	2.7	1.22	1.3	0.59	18.3	464	8.8	225
Kingbird	636.0	18/1	0.940	5527.3	27.100	27AH	2.7	1.22	1.3	0.59	18.3	464	8.8	225
Rook	636.0	24/7	0.977	5527.3	27.106	27AH	2.7	1.22	1.3	0.59	18.3	464	8.8	225
Grosbeak	636.0	26/7	0.990	5527.3	27.106	27AH	2.7	1.22	1.3	0.59	18.3	464	8.8	225
Egret	636.0	30/19	1.019	5527.3	27.106	27AH	2.7	1.22	1.3	0.59	18.3	464	8.8	225
Flamingo	666.6	24/7	1.000	5527.3	27.106	27AH	2.7	1.22	1.3	0.59	18.3	464	8.8	225
Stilt	715.5	24/7	1.036	5530.3	30.109	30AH	3.3	1.50	1.7	0.77	19.1	486	9.4	240
Starling	715.5	26/7	1.051	5530.3	30.109	30AH	3.3	1.50	1.7	0.77	19.1	486	9.4	240
Redwing	715.5	30/19	1.081	5530.3	30.116	30AH	3.3	1.50	1.7	0.77	19.1	486	9.4	240
Coot	795.0	36/1	1.040	5530.3	30.109	30AH	3.3	1.50	1.7	0.77	19.1	486	9.4	240

Tee Connector—5500 Series for ACSR Conductors, Open Run (cont.)

CODE WORD	CONDUCTOR			CATALOG NUMBER		DIE SIZE	WEIGHT				DIMENSIONS			
	SIZE	STRANDING	DIA.	RUN CONDUCTOR	BRANCH CONDUCTOR	ALUMINUM HEX DIE	RUN		BRANCH		A		B	
	KCMIL	AL/ST	IN				LBS	KG	LBS	KG	IN	MM	IN	MM
Tern	795.0	45/7	1.063	5530.3	30.116	30AH	3.3	1.50	1.7	0.77	19.1	486	9.4	240
Condor	795.0	54/7	1.093	5530.3	30.116	30AH	3.3	1.50	1.7	0.77	19.1	486	9.4	240
Drake	795.0	26/7	1.108	5530.3	30.116	30AH	3.3	1.50	1.7	0.77	19.1	486	9.4	240
Mallard	795.0	30/19	1.140	5530.3	30.122	30AH	3.3	1.50	1.7	0.77	19.1	486	9.4	240
Cuckoo	795.0	24/7	1.092	5530.3	30.116	30AH	3.3	1.50	1.7	0.77	19.1	486	9.4	240
Ruddy	900.0	45/7	1.131	5530.3	30.122	30AH	3.3	1.50	1.7	0.77	19.1	486	9.4	240
Canary	900.0	54/7	1.162	5530.3	30.122	30AH	3.3	1.50	1.7	0.77	19.1	486	9.4	240
Catbird	954.0	36/1	1.140	5530.3	30.122	30AH	3.3	1.50	1.7	0.77	19.1	486	9.4	240
Rail	954.0	45/7	1.165	5530.3	30.122	30AH	3.3	1.50	1.7	0.77	19.1	486	9.4	240
Cardinal	954.0	54/7	1.196	5530.3	30.125	30AH	3.3	1.50	1.7	0.77	19.1	486	10.1	256
Tanager	1033.5	36/1	1.186	5530.3	30.125	30AH	3.3	1.50	1.7	0.77	19.1	486	10.1	256
Ortolan	1033.5	45/7	1.212	5534.3	34.128	34AH	4.5	2.04	2.2	1.00	20.1	511	10.1	256
Curlew	1033.5	54/7	1.244	5534.3	34.134	34AH	4.5	2.04	2.2	1.00	20.1	511	10.1	256
Bluejay	1113.0	45/7	1.259	5534.3	34.134	34AH	4.5	2.04	2.2	1.00	20.1	511	10.1	256
Bunting	1192.5	45/7	1.302	5534.3	34.138	34AH	4.5	2.04	2.2	1.00	20.1	511	10.1	256
Bittern	1272.0	45/7	1.345	5536.3	36.144	36AH	5.0	2.27	2.5	1.13	21.0	533	10.6	270
Pheasant	1272.0	54/19	1.382	5536.3	36.147	36AH	5.0	2.27	2.5	1.13	21.0	533	10.6	270
Dipper	1351.5	45/7	1.386	5536.3	36.147	36AH	5.0	2.27	2.5	1.13	21.0	533	10.6	270
Martin	1351.5	54/19	1.424	5538.3	38.150	38AH	5.9	2.68	3.0	1.36	21.9	556	11.2	284
Bobolink	1431.0	45/7	1.427	5538.3	38.150	38AH	5.9	2.68	3.0	1.36	21.9	556	11.2	284
Plover	1431.0	54/19	1.465	5538.3	38.156	38AH	5.9	2.68	3.0	1.36	21.9	556	11.2	284
Nuthatch	1510.5	45/7	1.466	5538.3	38.156	38AH	5.9	2.68	3.0	1.36	21.9	556	11.2	284
Parrot	1510.5	54/19	1.506	5540.3	40.162	40AH	6.6	2.99	3.4	1.54	22.8	578	11.8	298
Lapwing	1590.0	45/7	1.504	5540.3	40.162	40AH	6.6	2.99	3.4	1.54	22.8	578	11.8	298
Falcon	1590.0	54/19	1.545	5540.3	40.162	40AH	6.6	2.99	3.4	1.54	22.8	578	11.8	298
Chukar	1780.0	84/19	1.602	5542.3	42.178	42AH	7.7	3.49	3.9	1.77	23.6	600	12.4	314
—	2034.0	72/7	1.681	5544.3	44.175	44AH	6.8	3.08	4.0	1.81	24.5	622	12.0	305
Bluebird	2156.0	84/19	1.762	5544.3	44.184	44AH	6.8	3.08	4.0	1.81	24.5	622	12.0	305
Kiwi	2167.0	72/7	1.737	5544.3	44.181	44AH	6.8	3.08	4.0	1.81	24.5	622	12.0	305
Thrasher	2312.0	76/19	1.802	5544.3	44.188	44AH	6.8	3.08	4.0	1.81	24.5	622	12.0	305
Joree	2515.0	76/19	1.880	5548.3	48.197	48AH	9.1	4.13	5.2	2.36	24.5	622	14.0	356

Tee Tap—5300 Series for ACSR Conductors, Open Run

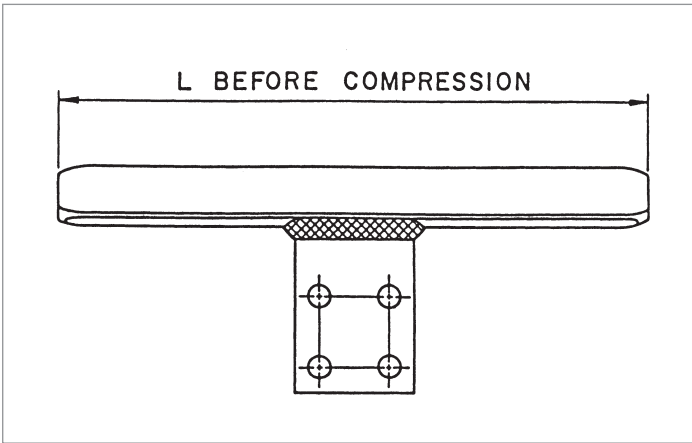

The 5300 Series Tee Tap is a permanent or temporary drop designed for ACSR conductors. It is fabricated from AFL seamless drawn aluminum.

The run portion incorporates an improved design of interlocking extrusions, providing a permanent grip on the conductor when compressed.

For die size sections 30AH and above, the end tapers of the compression portions of all compression accessories are supplied with a high voltage finish.

Ordering Instructions

Step 1: Catalog Number

Determine the catalog number based on the conductor being used.

Step 2: Extra High Voltage Finish

For Extra High Voltage Finish, use 'EHV'.

For Standard Finish, leave blank.

Step 3: Assemble Catalog Number.



Example:

For 795 Drake conductor with EHV finish, the complete catalog number is:

5330.3EHV

Notes:

1. Pad Dimensions are on page 117.
2. AFL Filler Compound (AFC) requirements are on page 115.
3. Bolt sizes and torque recommendations are on page 118.
4. Installation Instructions for Open Run Tee Taps are on page 144.

Tee Tap—5300 Series for ACSR Conductors, Open Run (cont.)

TEE TAP CATALOG NUMBER	CODE WORD	CONDUCTOR			DIE SIZE	TOTAL WEIGHT		DIMENSION A		PAD SIZE
		SIZE	STRANDING	DIA.		ALUMINUM HEX DIE	LBS	KG	IN	
		KCMIL	AL/ST	IN						
5374	Raven	1/0	6/1	0.398	74AH	0.5	0.20	7.6	192	B
5374	Quail	2/0	6/1	0.447	74AH	0.5	0.20	7.6	192	B
5375	Pigeon	3/0	6/1	0.502	75AH	0.7	0.34	8.6	217	B
5375	Penguin	4/0	6/1	0.563	75AH	0.7	0.34	8.6	217	B
5376	Waxwing	266.8	18/1	0.609	76AH	1.1	0.50	10.0	254	B
5376	Owl	266.8	6/7	0.633	76AH	1.1	0.50	10.0	254	B
5376	Partridge	266.8	26/7	0.642	76AH	1.1	0.50	10.0	254	B
5376	Ostrich	300.0	26/7	0.680	76AH	1.1	0.50	10.0	254	B
5376	Merlin	336.4	18/1	0.684	76AH	1.1	0.50	10.0	254	B
5376	Linnet	336.4	26/7	0.720	76AH	1.1	0.50	10.0	254	B
5376	Chickadee	397.5	18/1	0.743	76AH	1.1	0.50	10.0	254	B
5320.3	Linnet	336.4	26/7	0.720	20AH	1.2	0.54	12.5	318	B
5320.3	Oriole	336.4	30/7	0.741	20AH	1.2	0.54	12.5	318	B
5320.3	Chickadee	397.5	18/1	0.743	20AH	1.2	0.54	12.5	318	B
5320.3	Brant	397.5	24/7	0.772	20AH	1.2	0.54	12.5	318	B
5320.3	Ibis	397.5	26/7	0.783	20AH	1.2	0.54	12.5	318	B
5320.3	Lark	397.5	30/7	0.806	20AH	1.2	0.54	12.5	318	B
5324.3	Pelican	477.0	18/1	0.814	24AH	1.8	0.82	13.3	337	B
5324.3	Flicker	477.0	24/7	0.846	24AH	1.8	0.82	13.3	337	B
5324.3	Hawk	477.0	26/7	0.858	24AH	1.8	0.82	13.3	337	B
5324.3	Hen	477.0	30/7	0.883	24AH	1.8	0.82	13.3	337	B
5324.3	Osprey	556.5	18/1	0.879	24AH	1.8	0.82	13.3	337	B
5234.3	Parakeet	556.5	24/7	0.914	24AH	1.8	0.82	13.3	337	B
5324.3	Dove	556.5	26/7	0.927	24AH	1.8	0.82	13.3	337	B
5327.3	Eagle	556.5	30/7	0.953	27AH	3.0	1.36	15.3	387	D
5327.3	Peacock	605.0	24/7	0.953	27AH	3.0	1.36	15.3	387	D
5327.3	Squab	605.0	26/7	0.966	27AH	3.0	1.36	15.3	387	D
5327.3	Teal	605.0	30/19	0.994	27AH	3.0	1.36	15.3	387	D
5327.3	Swift	636.0	36/1	0.930	27AH	3.0	1.36	15.3	387	D
5327.3	Kingbird	636.0	18/1	0.940	27AH	3.0	1.36	15.3	387	D
5327.3	Rook	636.0	24/7	0.977	27AH	3.0	1.36	15.3	387	D
5327.3	Grosbeak	636.0	26/7	0.990	27AH	3.0	1.36	15.3	387	D
5327.3	Egret	636.0	30/19	1.019	27AH	3.0	1.36	15.3	387	D
5327.3	Flamingo	666.6	24/7	1.000	27AH	3.0	1.36	15.3	387	D
5330.3	Stilt	715.5	24/7	1.036	30AH	3.4	1.54	16.8	425	D
5330.3	Starling	715.5	26/7	1.051	30AH	3.4	1.54	16.8	425	D
5330.3	Redwing	715.5	30/19	1.081	30AH	3.4	1.54	16.8	425	D
5330.3	Coot	795.0	36/1	1.040	30AH	3.4	1.54	16.8	425	D
5330.3	Tern	795.0	45/7	1.063	30AH	3.4	1.54	16.8	425	D
5330.3	Condor	795.0	54/7	1.093	30AH	3.4	1.54	16.8	425	D

Tee Tap—5300 Series for ACSR Conductors, Open Run (cont.)

TEE TAP CATALOG NUMBER	CONDUCTOR				DIE SIZE	TOTAL WEIGHT		DIMENSION A		PAD SIZE
	CODE WORD	SIZE	STRANDING	DIA.		ALUMINUM HEX DIE	LBS	KG	IN	
		KCMIL	AL/ST	IN						
5330.3	Drake	795.0	26/7	1.108	30AH	3.4	1.54	16.8	425	D
5330.3	Mallard	795.0	30/19	1.140	30AH	3.4	1.54	16.8	425	D
5330.3	Cuckoo	795.0	24/7	1.092	30AH	3.4	1.54	16.8	425	D
5330.3	Ruddy	900.0	45/7	1.131	30AH	3.4	1.54	16.8	425	D
5330.3	Canary	900.0	54/7	1.162	30AH	3.4	1.54	16.8	425	D
5330.3	Catbird	954.0	36/1	1.140	30AH	3.4	1.54	16.8	425	D
5330.3	Rail	954.0	45/7	1.165	30AH	3.4	1.54	16.8	425	D
5330.3	Cardinal	954.0	54/7	1.196	30AH	3.4	1.54	16.8	425	D
5330.3	Tanager	1033.5	36/1	1.186	30AH	3.4	1.54	16.8	425	D
5334.3	Ortolan	1033.5	45/7	1.212	34AH	4.5	2.04	17.8	451	D
5334.3	Curlew	1033.5	54/7	1.244	34AH	4.5	2.04	17.8	451	D
5334.3	Bluejay	1113.0	45/7	1.259	34AH	4.5	2.04	17.8	451	D
5334.3	Bunting	1192.5	45/7	1.302	34AH	4.5	2.04	17.8	451	D
5336.3	Bittern	1272.0	45/7	1.345	36AH	4.7	2.13	18.5	470	D
5336.3	Pheasant	1272.0	54/19	1.382	36AH	4.7	2.13	18.5	470	D
5336.3	Dipper	1351.5	45/7	1.386	36AH	4.7	2.13	18.5	470	D
5338.3	Martin	1351.5	54/19	1.424	38AH	5.3	2.40	19.0	483	D
5338.3	Bobolink	1431.0	45/7	1.427	38AH	5.3	2.40	19.0	483	D
5338.3	Plover	1431.0	54/19	1.465	38AH	5.3	2.40	19.0	483	D
5338.3	Nuthatch	1510.5	45/7	1.466	38AH	5.3	2.40	19.0	483	D
5340.3	Parrot	1510.5	54/19	1.506	40AH	6.1	2.77	19.5	495	D
5340.3	Lapwing	1590.0	45/7	1.504	40AH	6.1	2.77	19.5	495	D
5340.3	Falcon	1590.0	54/19	1.545	40AH	6.1	2.77	19.5	495	D
5342.3	Chukar	1780.0	84/19	1.602	42AH	7.7	3.49	21.0	533	E
5344.3	—	2034.0	72/7	1.681	44AH	9.7	4.40	22.8	578	E
5344.3	Bluebird	2156.0	84/19	1.762	44AH	9.7	4.40	22.8	578	E
5344.3	Kiwi	2167.0	72/7	1.737	44AH	9.7	4.40	22.8	578	E
5344.3	Thrasher	2312.0	76/19	1.802	44AH	9.7	4.40	22.8	578	E
5348.3	Joree	2515.0	76/19	1.880	48AH	10.6	4.81	24.0	610	E
5344.3	Kiwi	2167.0	72/7	1.737	44AH	9.7	4.40	22.8	578	E
5344.3	Thrasher	2312.0	76/19	1.802	44AH	9.7	4.40	22.8	578	E
5348.3	Joree	2515.0	76/19	1.880	48AH	10.6	4.81	24.0	610	E

Compression Dead Ends—33100 Series for Extra High Strength ACSR Conductor, Eye Type, Single Tongue

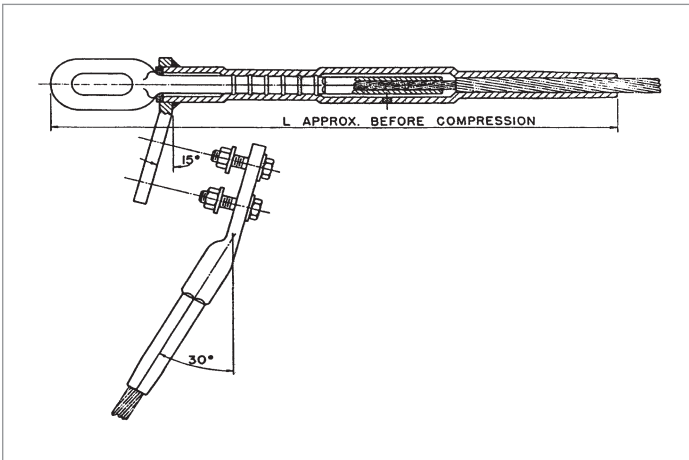

The 33100 Series Dead End Assembly is designed for Extra High Strength ACSR conductors (see page 19 for standard ACSR accessories). The aluminum body of the dead end is fabricated from AFL seamless drawn aluminum. The tongue and terminal pad are constructed with a 15° angle, which permits the terminal connector to be bolted in the straight or 30° position.

All dead ends are designed for full tension use, achieving a minimum of 95% of the ASTM rated strength of the conductor on which they are used. Each dead end assembly comes with a dead end body, steel eye, 15° terminal and aluminum hardware.

For die size sections 30AH and above, the end tapers of the compression portions of all compression accessories are supplied with a high voltage finish. Corona bolts are furnished as standard on 15° terminals for these section sizes.

The square edges of bolted pads on compression accessories could cause Corona in environments greater than or equal to 345 kV. Pads with edges and corners rounded can be supplied by adding the catalog suffix "EHV".

Ordering Instructions

Step 1: Assembly Catalog Number

Determine the assembly catalog number based on the conductor being used.

Step 2: Terminal Connector

For an assembly without a terminal connector, use 'NT'.
For an assembly with a terminal connector, leave blank.

Step 3: Extra High Voltage Finish

For Extra High Voltage Finish, use 'EHV'.
For Standard Finish, leave blank.

Step 4: Assemble Catalog Number.

Assy
Catalog
Number

+

Terminal
Connector

+

EHV
Finish

Example:

For 203.2 Brahma conductor with no terminal, the complete catalog number is:

E33193NT

Notes:

1. Eye Dimensions are on page 119.
2. Pad Dimensions are on page 117.
3. AFL Filler Compound (AFC) Requirements are on page 115.
4. Installation Instructions for Terminals are on page 134.

Compression Dead Ends—33100 Series for Extra High Strength ACSR Conductor, Eye Type, Single Tongue (cont.)

DEAD END ASSEMBLY CATALOG NUMBER	CODE WORD	CONDUCTOR			ALUMINUM BODY SINGLE TONGUE	STEEL EYE	15° TERMINAL CONNECTOR	DIE SIZE			TOTAL WEIGHT		DIMENSION L		PAD SIZE
		SIZE	STRANDING	DIA.				BODY	ALUMINUM HEX DIES	STEEL HEX DIES	LBS	KG	IN	MM	
		KCMIL	AL/ST	IN											
E33186	Petrel	101.8	12/7	0.461	8320.500	9110.295	5174.484	20AH	74AH	10SH	3.6	1.65	18.0	457	B
E33187	Minorca	110.8	12/7	0.481	8320.531	9110.302	5174.500	20AH	74AH	10SH	3.6	1.64	18.0	457	B
E33188	Leghorn	134.6	12/7	0.530	8324.552	9112.332	5175.547	24AH	75AH	12SH	4.9	2.19	19.5	495	B
E33189	Guinea	159.0	12/7	0.576	8324.625	9112.377	5175.609	24AH	75AH	12SH	4.6	2.08	19.5	495	B
E33190	Dotterel	176.9	12/7	0.607	8324.656	9112.386	5176.656	24AH	76AH	12SH	4.9	2.22	19.5	495	B
E33191	—	183.6	18/12	0.707	8330.750	9316.531	5176.750	30AH	76AH	16SH	8.2	3.74	21.4	545	B
E33192	Dorking	190.8	12/7	0.631	8324.688	9214.406	5176.688	24AH	76AH	14SH	5.5	2.49	20.3	514	B
E33193	Brahma	203.2	16/19	0.714	8330.750	9316.516	5176.750	30AH	76AH	16SH	8.2	3.74	21.4	545	B
E33194	Cochin	211.3	12/7	0.663	8324.719	9214.422	5176.719	24AH	76AH	14SH	5.4	2.43	20.3	514	B
E33195	—	261.1	12/19	0.737	8330.781	9314.453	5176.750	30AH	76AH	14SH	8.1	3.69	21.4	545	B

Compression Joints—43000 Series for Extra High Strength ACSR Conductors

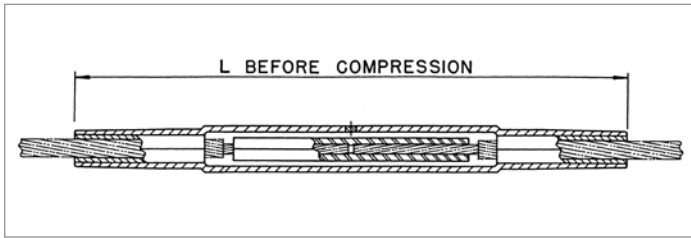

The 43000 Series Compression Joint Assembly is specifically designed for Extra High Strength ACSR conductors (see page 56 for standard ACSR Compression Joints). The joint is fabricated from AFL seamless drawn aluminum.

All compression joints are designed for full tension use, achieving a minimum of 95% of the ASTM rated strength of the conductor on which they are used. Each compression joint assembly comes with an aluminum joint and a steel sleeve.

For die size sections 30AH and above, the end tapers of the compression portions of all compression accessories are supplied with a high voltage finish.

JOINT ASSEMBLY CATALOG NUMBER	CODE NAME	CONDUCTOR			ALUMINUM JOINT CATALOG NUMBER	STEEL JOINT CATALOG NUMBER	DIE SIZE		WEIGHT		DIMENSION L	
		SIZE	STRANDING	DIA.			ALUMINUM HEX DIE	STEEL HEX DIE	LBS	KG	IN	MM
		KCMIL	AL/ST	IN								
43001	Petrel	101.8	12/7	0.461	8420.500	4010.295	20AH	10SH	7.8	6.63	15.3	387
43002	Minorca	110.8	12/7	0.481	8420.531	4010.302	20AH	10SH	1.9	0.82	16.5	419
43003	Leghorn	134.6	12/7	0.530	8424.562	4012.332	24AH	12SH	3.3	1.40	17.5	445
43004	Guinea	159.0	12/7	0.576	8424.625	4012.377	24AH	12SH	3.5	1.45	18.5	470
43005	Dotterel	176.9	12/7	0.607	8424.656	4012.386	24AH	12SH	3.3	1.40	19.3	489
43006	—	183.9	18/12	0.707	8430.750	4016.531	30AH	16SH	6.1	2.64	22.0	559
43007	Dorking	190.8	12/7	0.631	8424.688	4014.406	24AH	14SH	3.3	1.58	19.3	489
43008	Brahma	203.2	16/19	0.714	8430.750	4016.516	30AH	16SH	6.1	2.64	22.0	559
43009	Cochin	211.3	12/7	0.663	8424.719	4014.422	24AH	14SH	3.1	1.49	19.3	489
43010	—	219.9	8/7	0.608	8424.656	4010.295	20AH	10SH	2.2	0.91	16.3	413
43011	—	261.1	12/19	0.738	8430.781	4014.453	30AH	14SH	6.7	2.63	22.0	559

Ordering Instructions

Step 1: Assembly Catalog Number

Determine the assembly catalog number based on the conductor being used.

Example:

For 203.2 Brahma Conductor, the complete catalog number is:

43008

Notes:

1. AFL Filler Compound (AFC) Requirements are on page 115.
2. Installation Instructions for Joints are on page 141.

Compression Dead Ends—33500 Series for AAC Conductor, Eye or Clevis Type, Single Tongue

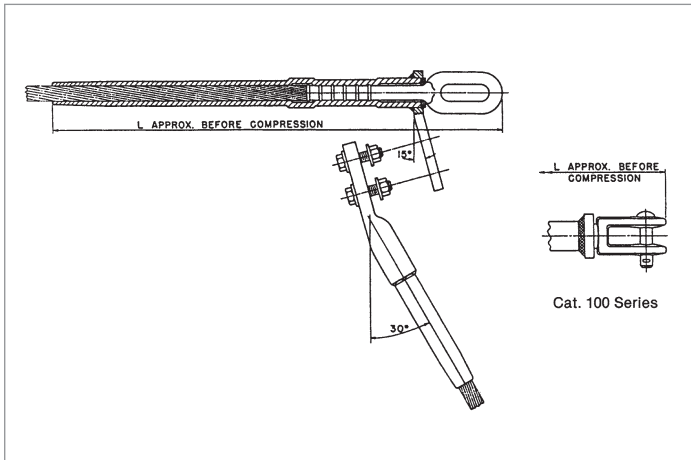

The 33500 Series Dead End Assembly is specifically designed for AAC conductors. The aluminum body of the dead end is fabricated from AFL seamless drawn aluminum. The tongue and terminal pad are constructed with a 15° angle, which permits the terminal connector to be bolted in the straight or 30° position.

All dead ends are designed for full tension use, achieving a minimum of 95% of the ASTM rated strength of the conductor on which they are used. Each dead end assembly comes with a dead end body, steel eye or clevis, 15° terminal and aluminum hardware.

For die size sections 30AH and above, the end tapers of the compression portions of all compression accessories are supplied with a high voltage finish. Corona bolts are furnished as standard on 15° terminals for these section sizes.

The square edges of bolted pads on compression accessories could cause Corona in environments greater than or equal to 345 kV. Pads with edges and corners rounded can be supplied by adding the catalog suffix "EHV".

Ordering Instructions

Step 1: Assembly Catalog Number

Determine the assembly catalog number based on the conductor being used.

Step 2: Terminal Connector

For an assembly without a terminal connector, use 'NT'.
For an assembly with a terminal connector, leave blank.

Step 3: Extra High Voltage Finish

For Extra High Voltage Finish, use 'EHV'.
For Standard Finish, leave blank.

Step 4: Assemble Catalog Number.

Assy
Catalog
Number

+

Terminal
Connector

+

EHV
Finish

Example:

For 795 Arbutus conductor with no terminal and EHV finish, the complete catalog number is:

E33516NTEHV

Notes:

1. Eye and Clevis Dimensions are on page 119.
2. Pad Dimensions are on page 117.
3. AFL Filler Compound (AFC) Requirements are on page 115.
4. Installation Instructions for Dead Ends are on page 133.
5. Installation Instructions for Terminals are on page 131.

Compression Dead Ends—33500 Series for AAC Conductor, Eye or Clevis Type, Single Tongue (cont.)

DEAD END ASSEMBLY CATALOG NUMBER	CONDUCTOR				ALUMINUM BODY SINGLE TONGUE	STEEL COMPONENT		15° TERMINAL CONNECTOR	DIE SIZE	TOTAL WEIGHT		DIMENSIONS L		PAD SIZE
	CODE WORD	SIZE	STRANDING	DIA.		STEEL EYE	STEEL CLEVIS			ALUMINUM HEX DIES	LBS	KG	IN	
		KCMIL	AL	IN										
C33501	Aster	2/0	7	0.414	7174.438	—	A100X	5174.438	74AH	2.1	0.97	10.8	275	B
C33501	Buttercup	2/0	19	0.419	7174.438	—	A100X	5174.438	74AH	2.1	0.97	10.8	275	B
C33502	Phlox	3/0	7	0.464	7174.484	—	A100X	5174.484	74AH	1.9	0.84	10.8	275	B
C33502	Primrose	3/0	19	0.470	7174.484	—	A100X	5174.484	74AH	1.9	0.84	10.8	275	B
C33503	Oxlip	4/0	7	0.522	7175.547	—	A102X	5175.547	75AH	3.5	1.56	12.4	316	B
C33503	Sunflower	4/0	19	0.528	7175.547	—	A102X	5175.547	75AH	3.5	1.56	12.4	316	B
C33504	Sneezewort	250.0	7	0.567	7175.609	—	A102X	5175.609	75AH	3.3	1.50	12.4	316	B
C33504	Valerian	250.0	19	0.575	7175.609	—	A102X	5175.609	75AH	3.3	1.50	12.4	316	B
C33504	Dandelion	250.0	37	0.575	7175.609	—	A102X	5175.609	75AH	3.3	1.50	12.4	316	B
C33504	Daisy	266.8	7	0.586	7175.609	—	A102X	5175.809	75AH	3.3	1.60	12.4	316	B
C33504	Laurel	266.8	19	0.593	7175.609	—	A102X	5175.609	75AH	3.5	1.50	12.4	318	B
C33505	Peony	300.0	19	0.629	7176.656	—	A101X	5176.656	76AH	3.0	1.77	14.1	357	B
C33505	Avgave	300.0	37	0.629	7176.656	—	A101X	5176.656	76AH	3.0	1.77	14.1	357	B
C33506	Tulip	336.4	19	0.666	7176.688	—	A103X	5176.688	76AH	3.6	1.62	14.1	357	B
E33507	Daffodil	350.0	19	0.681	7120.719	9100	—	5120.719	20AH	3.7	1.68	17.5	445	B
E33507	Gardenia	350.0	37	0.681	7120.719	9100	—	5120.719	20AH	3.7	1.68	17.5	445	B
C33508	Canna	397.5	19	0.724	7176.750	—	A103X	5176.750	76AH	3.4	1.56	14.1	357	B
E33509	Goldentuft	450.0	19	0.772	7120.812	9100	—	5120.812	20AH	3.6	1.62	17.5	445	B
E33509	Yarrow	450.0	37	0.772	7120.812	9100	—	5120.812	20AH	3.6	1.62	17.5	445	B
E33509	Cosmos	477.0	19	0.793	7120.812	9100	—	5120.812	20AH	3.6	1.62	17.5	445	B
E33509	Syringa	477.0	37	0.795	7120.812	9100	—	5120.812	20AH	3.6	1.62	17.5	445	B
E33510	Cosmos	477.0	19	0.793	7124.875	9100	—	5124.875	24AH	4.9	2.23	18.3	464	B
E33510	Syringa	477.0	37	0.795	7124.875	9100	—	5124.875	24AH	4.9	2.23	18.3	464	B
E33510	Zinna	500.0	19	0.811	7124.875	9100	—	5124.875	24AH	4.9	2.23	18.3	464	B
E33510	Hyacinth	500.0	37	0.813	7124.875	9100	—	5124.875	24AH	4.9	2.23	18.3	464	B
E33511	Dahlia	556.5	19	0.856	7124.938	9100	—	5124.938	24AH	4.7	2.13	18.3	464	B
E33511	Mistletoe	556.5	37	0.858	7124.938	9100	—	5124.938	24AH	4.7	2.13	18.3	464	B
E33512	Meadowsweet	600.0	37	0.891	7124.938C	9200	—	5124.938	24AH	5.1	2.32	18.4	467	B
E33512	Lotus	600.0	61	0.893	7124.938C	9200	—	5124.938	24AH	5.1	2.32	18.4	467	B
E33513	Orchid	636.0	37	0.918	7124.969	9200	—	5124.969	24AH	6.4	2.32	18.4	467	B
E33513	Heuchera	650.0	37	0.928	7124.969	9200	—	5124.969	24AH	6.3	2.32	18.4	467	B
E33514	Verbena	700.0	37	0.963	7127.100	9200	—	5127.100	27AH	6.7	3.09	20.6	524	D
E33514	Flag	700.0	61	0.964	7127.100	9200	—	5127.100	27AH	6.7	3.09	20.6	524	D
E33515	Violet	715.5	37	0.974	7127.106	9200	—	5127.106	27AH	7.4	3.04	20.6	524	D
E33515	Nasurtium	715.5	61	0.975	7127.106	9200	—	5127.106	27AH	7.4	3.04	20.6	524	D
E33515	Petunia	750.0	37	0.997	7127.106	9200	—	5127.106	27AH	7.4	3.04	20.6	524	D
E33515	Cattail	750.0	61	0.998	7127.106	9200	—	5127.106	27AH	7.4	3.04	20.6	524	D
E33516	Arbutus	795.0	37	1.026	7130.109	9300	—	5130.109	30AH	9.0	3.99	20.8	529	D

Compression Dead Ends—33500 Series for AAC Conductor, Eye or Clevis Type, Single Tongue (cont.)

DEAD END ASSEMBLY CATALOG NUMBER	CONDUCTOR				ALUMINUM BODY SINGLE TONGUE	STEEL COMPONENT		15° TERMINAL CONNECTOR	DIE SIZE	TOTAL WEIGHT		DIMENSIONS L		PAD SIZE
	CODE WORD	SIZE	STRANDING	DIA.		STEEL EYE	STEEL CLEVIS		ALUMINUM HEX DIES	LBS	KG	IN	MM	
		KCMIL	AL	IN										
E33516	—	800.0	37	1.031	7130.109	9300	—	5130.109	30AH	9.0	3.99	20.8	529	D
E33516	Heliotrope	800.0	61	1.031	7130.109	9300	—	5130.109	30AH	9.0	3.99	20.8	529	D
E33517	Cockscomb	900.0	37	1.092	7130.116	9300	—	5130.116	30AH	8.9	4.04	21.8	554	D
E33517	Snapdragon	900.0	61	1.094	7130.116	9300	—	5130.116	30AH	8.9	4.04	21.8	554	D
E33518	Magnolia	954.0	37	1.124	7130.122	9300	—	5130.122	30AH	8.8	3.99	23.1	586	D
E33518	Goldenrod	954.0	61	1.126	7130.122	9300	—	5130.122	30AH	8.8	3.99	23.1	586	D
E33518	Hawkweed	1000.0	37	1.150	7130.122	9300	—	5130.122	30AH	9.9	3.99	23.1	586	D
E33518	Camellia	1000.0	61	1.152	7130.122	9300	—	5130.122	30AH	9.9	3.99	23.1	586	D
E33519	Bluebell	1033.5	37	1.170	7130.122	9400	—	5130.122	30AH	10.4	4.31	23.2	589	D
E33519	Larkspur	1033.5	61	1.172	7130.122	9400	—	5130.122	30AH	10.4	4.31	23.2	589	D
E33520	Marigold	1113.0	61	1.216	7134.128	9400	—	5134.128	34AH	11.5	5.31	22.9	583	D
E33521	Hawthorn	1192.5	61	1.258	7134.134	9400	—	5134.134	34AH	11.7	5.18	23.4	595	D
E33522	Narcissus	1272.0	61	1.300	7134.134	E9500	—	5134.134	34AH	12.0	5.31	23.6	598	D
E33523	Columbine	1351.5	61	1.340	7136.144	E9500	—	5136.144	36AH	12.2	5.57	24.3	617	D
E33523	Carnation	1431.0	61	1.379	7136.144	E9500	—	5136.144	36AH	12.2	5.57	24.3	617	D
E33524	—	1500.0	91	1.412	7136.147	E9500	—	5136.147	36AH	12.6	5.53	24.3	617	D
E33524	Gladiolus	1510.5	61	1.417	7136.147	E9500	—	5136.147	36AH	14.5	5.53	24.3	617	D
E33525	Coreopsis	1590.0	61	1.454	7138.156	E9600	—	5138.156	38AH	16.8	6.31	24.6	624	D
E33525	Dogwood	1590.0	91	1.454	7138.156	E9600	—	5138.156	38AH	16.8	6.31	24.6	624	D
E33526	Jessamine	1750.0	61	1.525	7140.162	E9600	—	5140.162	40AH	18.8	7.57	24.6	624	E
E33527	Cowslip	2000.0	91	1.630	7142.178	E9700	—	5142.178	42AH	19.7	8.57	25.9	658	E
E33528	Sagebrush	2250.0	91	1.729	7144.181	E9800	—	5144.181	44AH	22.3	10.24	25.8	654	E
E33528	—	2300.0	61	1.750	7144.181	E9800	—	5144.181	44AH	24.8	10.24	25.8	654	E
E33528	—	2300.0	91	1.750	7144.181	E9800	—	5145.181	44AH	24.8	10.24	25.8	654	E
E33529	Lupine	2500.0	91	1.823	7144.188	E9800	—	5144.188	44AH	14.0	10.02	25.8	654	E
E33530	Bitterroot	2750.0	91	1.912	7148.197	E9800	—	5148.197	48AH	16.1	12.11	28.6	725	E

Compression Dead Ends—33600 Series for AAC Conductor, Eye or Clevis Type, Double Tongue

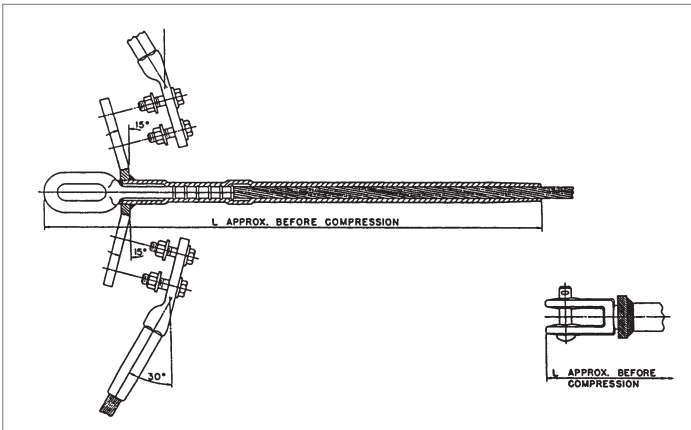

The 33600 Series Double Tongue Dead End Assembly is specifically designed for AAC conductors. The aluminum body of the dead end is fabricated from AFL seamless drawn aluminum. The tongue and terminal pad are constructed with a 15° angle, which permits the terminal connector to be bolted in the straight or 30° position.

All dead ends are designed for full tension use, achieving a minimum of 95% of the ASTM rated strength of the conductor on which they are used. Each dead end assembly comes with a dead end body, steel eye or clevis, two 15° terminals and aluminum hardware.

For die size sections 30AH and above, the end tapers of the compression portions of all compression accessories are supplied with a high voltage finish. Corona bolts are furnished as standard on 15° terminals for these section sizes.

The square edges of bolted pads on compression accessories could cause Corona in environments greater than or equal to 345 kV. Pads with edges and corners rounded can be supplied by adding the catalog suffix "EHV".

Ordering Instructions

Step 1: Assembly Catalog Number

Determine the assembly catalog number based on the conductor being used.

Step 2: Terminal Connector

For an assembly without a terminal connector, use 'NT'.
For an assembly with a terminal connector, leave blank.

Step 3: Extra High Voltage Finish

For Extra High Voltage Finish, use 'EHV'.
For Standard Finish, leave blank.

Step 4: Assemble Catalog Number.



Example:

For 795 Arbutus conductor with no terminal and EHV finish, the complete catalog number is:

E33616NTEHV

Notes:

1. Eye and Clevis Dimensions are on page 119.
2. Pad Dimensions are on page 117.
3. AFL Filler Compound (AFC) Requirements are on page 115.
4. Installation Instructions for Dead Ends are on page 133.
5. Installation Instructions for Terminals are on page 131.

Compression Dead Ends—33600 Series for AAC Conductor, Eye or Clevis Type, Double Tongue (cont.)

DEAD END ASSEMBLY CATALOG NUMBER	CONDUCTOR				ALUMINUM BODY DOUBLE TONGUE	STEEL COMPONENT		15° TERMINAL CONNECTOR	DIE SIZE	TOTAL WEIGHT		DIMENSIONS L		PAD SIZE
	CODE WORD	SIZE	STRANDING	DIA.		STEEL EYE	STEEL CLEVIS			ALUM. HEX DIES	LBS	KG	IN	
		KCMIL	AL	IN										
C33601	Aster	2/0	7	0.414	7274.438	—	A100X	5174.438	74AH	2.9	1.31	10.8	257	B
C33601	Buttercup	2/0	19	0.419	7274.438	—	A100X	5174.438	74AH	2.9	1.31	10.8	275	B
C33602	Phlox	3/0	7	0.464	7274.484	—	A100X	5174.484	74AH	2.6	1.17	10.8	275	B
C33602	Primrose	3/0	19	0.470	7274.484	—	A100X	5174.484	74AH	2.6	1.17	10.8	275	B
C33603	Oxlip	4/0	7	0.522	7275.547	—	A102X	5175.547	75AH	3.9	1.75	12.4	316	B
C33603	Sunflower	4/0	19	0.528	7275.547	—	A102X	5175.547	75AH	3.9	1.75	12.4	316	B
C33604	Sneezewort	250.0	7	0.567	7275.609	—	A102X	5175.609	75AH	3.7	1.68	12.4	316	B
C33604	Valerian	250.0	19	0.575	7275.609	—	A102X	5176.609	75AH	3.7	1.68	12.4	316	B
C33604	Dandelion	250.0	37	0.575	7276.609	—	A102X	5177.609	75AH	3.7	1.68	12.4	316	B
C33604	Daisy	266.8	7	0.586	7275.609	—	A102X	5175.809	75AH	3.7	1.68	12.4	316	B
C33604	Laurel	266.8	19	0.693	7275.609	—	A102X	5175.609	75AH	3.9	1.68	12.4	318	B
C33605	Peony	300.0	19	0.629	7276.656	—	A101X	5176.656	76AH	3.4	1.95	14.1	357	B
C33605	Avgave	300.0	37	0.629	7277.656	—	A101X	5177.656	76AH	3.4	1.95	14.1	357	B
C33606	Tulip	336.4	19	0.666	7276.688	—	A103X	5176.688	76AH	4.0	1.81	14.1	357	B
E33607	Daffodil	350.0	19	0.681	7220.719	9100	—	5120.719	20AH	4.2	1.90	17.5	445	B
E33607	Gardenia	350.0	37	0.681	7220.719	9100	—	5120.719	20AH	4.2	1.90	17.5	445	B
C33608	Canna	397.5	19	0.724	7276.750	—	A103X	5176.750	76AH	3.8	1.74	14.1	357	B
E33609	Goldentuft	450.0	19	0.772	7220.812	9100	—	5120.812	20AH	4.1	1.85	17.5	445	B
E33609	Yarrow	450.0	37	0.772	7220.812	9100	—	5120.812	20AH	4.1	1.85	17.5	445	B
E33609	Cosmos	477.0	19	0.793	7220.812	9100	—	5120.812	20AH	4.1	1.85	17.5	445	B
E33609	Syringa	477.0	37	0.795	7220.812	9100	—	5120.812	20AH	4.1	1.85	17.5	445	B
E33610	Cosmos	477.0	19	0.793	7224.875	9100	—	5124.875	24AH	5.4	2.45	18.3	464	B
E33610	Syringa	477.0	37	0.795	7224.875	9100	—	5124.875	24AH	5.4	2.45	18.3	464	B
E33610	Zinna	500.0	19	0.811	7224.875	9100	—	5124.875	24AH	5.4	2.45	18.3	464	B
E33610	Hyacinth	500.0	37	0.813	7224.875	9100	—	5124.875	24AH	5.4	2.45	18.3	464	B
E33611	Dahlia	556.5	19	0.856	7224.938	9100	—	5124.938	24AH	5.2	2.36	18.3	464	B
E33611	Mistletoe	556.5	37	0.858	7224.938	9100	—	5124.938	24AH	5.2	2.36	18.3	464	B
E33612	Meadowsweet	600.0	37	0.891	7224.938C	9200	—	5124.938	24AH	5.5	2.50	18.4	467	B
E33612	Lotus	600.0	61	0.893	7224.938C	9200	—	5124.938	24AH	5.5	2.50	18.4	467	B
E33613	Orchid	636.0	37	0.918	7224.969	9200	—	5124.969	24AH	5.5	2.50	18.4	467	B
E33613	Heuchera	650.0	37	0.928	7224.969	9200	—	5124.969	24AH	5.5	2.50	18.4	467	B
E33614	Verbena	700.0	37	0.963	7227.100	9200	—	5127.100	27AH	7.6	3.45	20.6	524	D
E33614	Flag	700.0	61	0.964	7227.100	9200	—	5127.100	27AH	7.6	3.45	20.6	524	D
E33615	Violet	715.5	37	0.974	7227.106	9200	—	5127.106	27AH	7.5	3.40	20.6	524	D
E33615	Nasurtium	715.5	61	0.975	7227.106	9200	—	5127.106	27AH	7.5	3.40	20.6	524	D
E33615	Petunia	750.0	37	0.997	7227.106	9200	—	5127.106	27AH	7.5	3.40	20.6	524	D
E33615	Cattail	750.0	61	0.998	7227.106	9200	—	5127.106	27AH	7.5	3.40	20.6	524	D
E33616	Arbutus	795.0	37	1.026	7230.109	9300	—	5130.109	30AH	9.7	4.40	20.8	529	D
E33616	Lilac	795.0	61	1.028	7230.109	9300	—	5130.109	30AH	9.7	4.40	20.8	529	D
E33616	—	800.0	37	1.031	7230.109	9300	—	5130.109	30AH	9.7	4.40	20.8	529	D
E33616	Heliotrope	800.0	61	1.031	7230.109	9300	—	5130.109	30AH	9.7	4.40	20.8	529	D

Compression Dead Ends—33600 Series for AAC Conductor, Eye or Clevis Type, Double Tongue (cont.)

DEAD END ASSEMBLY CATALOG NUMBER	CODE WORD	CONDUCTOR			ALUMINUM BODY DOUBLE TONGUE	STEEL COMPONENT		15° TERMINAL CONNECTOR	DIE SIZE	TOTAL WEIGHT		DIMENSIONS L		PAD SIZE
		SIZE	STRANDING	DIA.		STEEL EYE	STEEL CLEVIS		ALUM. HEX DIES	LBS	KG	IN	MM	
E33617	Cockscomb	900.0	37	1.092	7230.116	9300	—	5130.116	30AH	9.8	4.45	21.8	554	D
E33617	Snapdragon	900.0	61	1.094	7230.116	9300	—	5130.116	30AH	9.8	4.45	21.8	554	D
E33618	Magnolia	954.0	37	1.124	7230.122	9300	—	5130.122	30AH	9.7	4.40	23.1	586	D
E33618	Goldenrod	954.0	61	1.126	7230.122	9300	—	5130.122	30AH	9.7	4.40	23.1	586	D
E33618	Hawkweed	1000.0	37	1.152	7230.122	9300	—	5130.122	30AH	9.7	4.40	23.1	586	D
E33618	Camellia	1000.0	61	1.152	7230.122	9300	—	5130.122	30AH	9.7	4.40	23.1	586	D
E33619	Bluebell	1033.5	37	1.170	7230.122	9400	—	5130.122	30AH	10.4	4.72	23.2	589	D
E33619	Larkspur	1033.5	61	1.172	7230.122	9400	—	5130.122	30AH	10.4	4.72	23.2	589	D
E33620	Marigold	1113.0	61	1.216	7234.128	9400	—	5134.128	34AH	12.5	5.67	22.9	583	D
E33621	Hawthorn	1192.5	61	1.258	7234.134	9400	—	5134.134	34AH	12.2	5.54	23.4	595	D
E33622	Narcissus	1272.0	61	1.300	7234.134	E9500	—	5134.134	34AH	12.5	5.67	23.6	598	D
E33623	Columbine	1351.5	61	1.340	7236.144	E9500	—	5136.144	36AH	13.1	5.94	24.3	617	D
E33623	Carnation	1431.0	61	1.379	7236.144	E9500	—	5136.144	36AH	13.1	5.94	24.3	617	D
E33624	—	1500.0	91	1.412	7236.147	E9500	—	5136.147	36AH	13.0	5.89	24.3	617	D
E33624	Gladiolus	1510.5	61	1.417	7236.147	E9500	—	5136.147	36AH	13.0	5.89	24.3	617	D
E33625	Coreopsis	1590.0	61	1.454	7238.156	E9600	—	5138.156	38AH	14.8	6.72	24.6	624	D
E33625	Dogwood	1590.0	91	1.454	7238.156	E9600	—	5138.156	38AH	14.8	6.72	24.6	624	D
E33626	Jessamine	1750.0	61	1.525	7240.162	E9600	—	5140.162	40AH	18.5	8.39	24.6	624	E
E33627	Cowslip	2000.0	91	1.630	7242.178	E9700	—	5142.178	42AH	19.4	8.80	25.9	658	E
E33628	Sagebrush	2250.0	91	1.729	7244.181	E9800	—	5144.181	44AH	23.0	10.43	25.8	654	E
E33628	—	2300.0	61	1.750	7244.181	E9800	—	5144.181	44AH	23.0	10.43	25.8	654	E
E33628	—	2300.0	91	1.750	7245.181	E9801	—	5145.181	44AH	23.0	10.43	25.8	654	E
E33629	Lupine	2500.0	91	1.823	7244.188	E9800	—	5144.188	44AH	22.5	10.20	25.8	654	E
E33630	Bitterroot	2750.0	91	1.912	7248.197	E9800	—	5148.197	48AH	27.7	12.57	28.6	725	E

Compression Dead Ends—43200 Series for AAC Conductor, Adjustable Clevis Type, Single Tongue

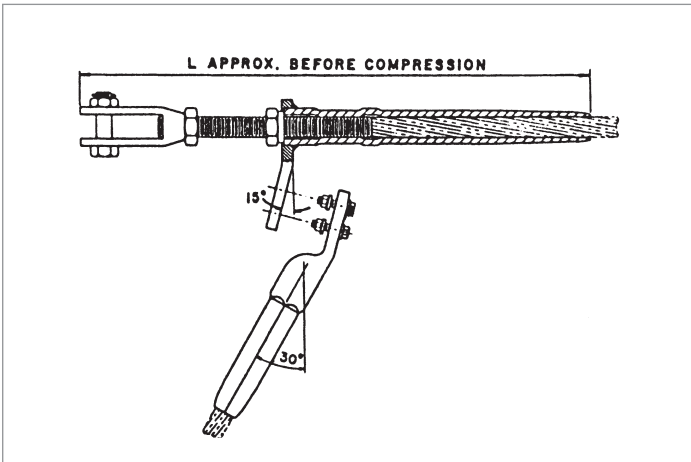

The 43200 Series Adjustable Clevis Dead End Assembly is specifically designed for AAC conductors. The aluminum body of the dead end is fabricated from AFL seamless drawn aluminum. The tongue and terminal pad are constructed with a 15° angle, which permits the terminal connector to be bolted in the straight of 30° position.

All dead ends are designed for full tension use, achieving a minimum of 95% of the ASTM rated strength of the conductor on which they are used. Each dead end assembly comes with a dead end body, adjustable steel clevis, 15° terminal and aluminum hardware.

For die size sections 30AH and above, the end tapers of the compression portions of all compression accessories are supplied with a high voltage finish. Corona bolts are furnished as standard on 15° terminals for these section sizes.

The square edges of bolted pads on compression accessories could cause Corona in environments greater than or equal to 345 kV. Pads with edges and corners rounded can be supplied by adding the catalog suffix "EHV".

Ordering Instructions

Step 1: Assembly Catalog Number

Determine the assembly catalog number based on the conductor being used.

Step 2: Terminal Connector

For an assembly without a terminal connector, use 'NT'.
For an assembly with a terminal connector, leave blank.

Step 3: Extra High Voltage Finish

For Extra High Voltage Finish, use 'EHV'.
For Standard Finish, leave blank.

Step 4: Assemble Catalog Number.



Example:

For 795 Arbutus conductor with no terminal and EHV finish, the complete catalog number is:

C43217NTEHV

Notes:

1. Adjustable Clevis Dimensions are on page 120.
2. Pad Dimensions are on page 117.
3. AFL Filler Compound (AFC) Requirements are on page 115.
4. Installation Instructions for Dead Ends are on page 133.
5. Installation Instructions for Terminals are on page 131.

Compression Dead Ends—43200 Series for AAC Conductor, Adjustable Clevis Type, Single Tongue (cont.)

DEAD END ASSEMBLY CATALOG NUMBER	CODE WORD	CONDUCTOR			ALUMINUM BODY SINGLE TONGUE	ADJUSTABLE STEEL CLEVIS	15° TERMINAL CONNECTOR	DIE SIZE	TOTAL WEIGHT		DIMENSION L		PAD SIZE
		SIZE	STANDING	DIA.					ALUMINUM HEX DIES	LBS	KG	IN	
		KCMIL	AL	IN									
C43210	Daffodil	350.0	19	0.681	7120.719	C6100	5120.719	20AH	6.0	2.72	24.3	616	B
C43210	Gardenia	350.0	37	0.681	7120.719	C6100	5120.719	20AH	6.0	2.72	24.3	616	B
C43211	Canna	397.5	19	0.724	7120.812	C6100	5120.812	20AH	5.9	2.66	24.3	616	B
C43211	Goldentuft	450.0	19	0.772	7120.812	C6100	5121.812	20AH	5.9	2.66	24.3	616	B
C43211	Yarrow	450.0	37	0.772	7120.812	C6100	5120.812	20AH	5.9	2.66	24.3	616	B
C43211	Cosmos	477.0	19	0.793	7120.812	C6100	5121.812	20AH	5.9	2.66	24.3	616	B
C43212	Syringa	477.0	37	0.795	7124.875	C6100	5124.875	24AH	7.2	3.27	25.0	635	B
C43212	Cosmos	477.0	19	0.793	7125.875	C6100	5125.875	24AH	7.2	3.27	25.0	635	B
C43212	Syringa	477.0	37	0.795	7124.875	C6100	5124.875	24AH	7.2	3.27	25.0	635	B
C43212	Zinna	500.0	19	0.811	7124.875	C6100	5124.875	24AH	7.2	3.27	25.0	635	B
C43212	Hyacinth	500.0	37	0.813	7124.875	C6200	5124.875	24AH	7.7	3.50	25.1	638	B
C43213	Dahlia	556.5	19	0.858	7124.938C	C6200	5125.938	24AH	7.7	3.50	25.1	638	B
C43213	Mistletoe	556.5	37	0.858	7124.938C	C6200	5124.938	24AH	7.7	3.50	25.1	638	B
C43213	Meadowsweet	600.0	37	0.891	7124.938C	C6200	5125.938	24AH	7.7	3.50	25.1	638	B
C43214	Lotus	600.0	61	0.893	7124.969C	C6200	5124.969	24AH	7.6	3.45	25.1	638	B
C43214	Orchid	636.0	37	0.918	7124.969C	C6200	5125.969	24AH	7.6	3.45	25.1	638	B
C43214	Heuchera	650.0	37	0.928	7124.969C	C6200	5124.969	24AH	7.6	3.45	25.1	638	B
C43215	Verbena	700.0	37	0.964	7127.100	C6200	5127.100	27AH	9.4	4.27	27.4	695	D
C43216	Violet	715.5	37	0.975	7127.106	C6200	5127.106	27AH	9.3	4.22	27.4	695	D
C43216	Nasurtium	715.5	61	0.975	7127.106	C6200	5127.106	27AH	9.3	4.22	27.4	695	D
C43216	Petunia	750.0	37	0.998	7127.106	C6200	5127.106	27AH	9.3	4.22	27.4	695	D
C43216	Cattail	750.0	61	0.998	7127.106	C6200	5127.106	27AH	9.3	4.22	27.4	695	D
C43217	Arbutus	795.0	37	1.028	7130.109	C6300	5130.109	30AH	14.3	6.48	29.8	757	D
C43217	Lilac	795.0	61	1.028	7130.109	C6300	5130.109	30AH	14.3	6.48	29.8	757	D
C43217	—	800.0	37	1.031	7130.109	C6300	5130.109	30AH	14.3	6.48	29.8	757	D
C43217	Heliotrope	800.0	61	1.031	7130.109	C6300	5130.109	30AH	14.3	6.48	29.8	757	D
C43218	Cockscomb	900.0	37	1.094	7130.116	C6300	5130.116	30AH	14.4	6.53	30.8	783	D
C43218	Snapdragon	900.0	61	1.094	7130.116	C6300	5130.116	30AH	14.4	6.53	30.8	783	D
C43219	Magnolia	954.0	37	1.126	7130.122	C6400	5130.122	30AH	15.1	6.85	32.2	818	D
C43219	Goldenrod	954.0	61	1.126	7130.122	C6400	5130.122	30AH	15.1	6.85	32.2	818	D
C43219	Hawkweed	1000.0	37	1.152	7130.122	C6400	5130.122	30AH	14.1	6.85	32.2	818	D
C43219	Camellia	1000.0	61	1.152	7130.122	C6400	5130.122	30AH	14.1	6.85	32.2	818	D
C43219	Bluebell	1033.5	37	1.172	7130.122	C6400	5130.122	30AH	15.1	6.85	32.2	818	D
C43219	Larkspur	1033.5	61	1.172	7130.122	C6400	5130.122	30AH	15.1	6.85	32.2	818	D

Compression Dead Ends—43200 Series for AAC Conductor, Adjustable Clevis Type, Single Tongue (cont.)

DEAD END ASSEMBLY CATALOG NUMBER	CODE WORD	CONDUCTOR			ALUMINUM BODY SINGLE TONGUE	ADJUSTABLE STEEL CLEVIS	15° TERMINAL CONNECTOR	DIE SIZE	TOTAL WEIGHT		DIMENSION L		PAD SIZE
		SIZE	STANDING	DIA.					ALUMINUM HEX DIES	LBS	KG	IN	
		KCMIL	AL	IN									
C43220	Marigold	1113.0	61	1.216	7134.128	C6400	5134.128	34AH	17.3	7.85	32.0	813	D
C43221	Hawthorn	1192.5	61	1.258	7134.134	C6400	5134.134	34AH	17.0	7.72	32.4	824	D
C43221	Narcissus	1272.0	61	1.300	7134.134	C6400	5134.134	34AH	17.0	7.72	32.4	824	D
C43222	Columbine	1351.5	61	1.340	7136.144	C6500	5136.144	36AH	18.7	8.47	33.4	848	D
C43222	Carnation	1431.0	61	1.379	7136.144	C6500	5136.144	36AH	18.7	8.47	33.4	848	D
C43223	—	1500.0	91	1.412	7136.147	C6500	5136.147	36AH	18.6	8.43	33.4	848	D
C43223	Gladiolus	1510.5	61	1.417	7136.147	C6500	5136.147	36AH	18.6	8.43	33.4	848	D
C43224	Coreopsis	1590.0	61	1.454	7138.156	C6500	5138.156	38AH	19.6	8.89	33.6	854	D
C43224	Dogwood	1590.0	91	1.454	7138.156	C6500	5138.156	38AH	19.6	8.89	33.6	854	D
C43225	Jessamine	1750.0	61	1.525	7140.162	C6600	5140.162	40AH	26.3	11.93	36.2	919	E
C43226	Cowslip	2000.0	91	1.630	7142.178C	C6700	5142.178	42AH	29.0	13.16	37.6	954	E
C43227	Sagebrush	2250.0	91	1.729	7144.181	C6700	5144.181	44AH	31.3	14.19	37.1	943	E
C43227	—	2300.0	61	1.750	7144.181	C6700	5144.181	44AH	31.1	14.19	37.1	943	E
C43227	—	2300.0	91	1.750	7144.181	C6700	5144.181	44AH	31.2	14.19	37.1	943	E
C43228	Lupine	2500.0	91	1.823	7144.188	C6700	5144.188	44AH	30.8	13.97	37.1	943	E
C43229	Bitterroot	2750.0	91	1.912	7148.197	C6800	5148.197	48AH	41.4	18.78	40.4	1027	E

Compression Dead Ends—43300 Series for AAC Conductor, Adjustable Clevis Type, Double Tongue

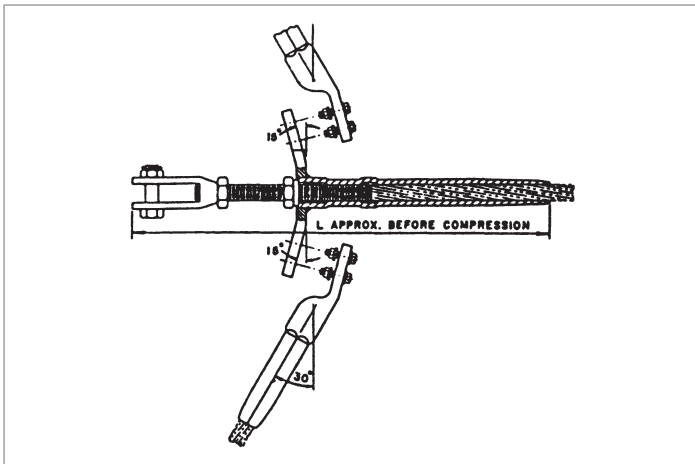

The 43300 Series Adjustable Clevis Dead End Assembly is specifically designed for AAC conductors. The aluminum body of the dead end is fabricated from AFL seamless drawn aluminum. The tongue and terminal pad are constructed with a 15° angle, which permits the terminal connector to be bolted in the straight of 30° position.

All dead ends are designed for full tension use, achieving a minimum of 95% of the ASTM rated strength of the conductor on which they are used. Each dead end assembly comes with a dead end body, adjustable steel clevis, two 15° terminals and aluminum hardware.

For die size sections 30AH and above, the end tapers of the compression portions of all compression accessories are supplied with a high voltage finish. Corona bolts are furnished as standard on 15° terminals for these section sizes.

The square edges of bolted pads on compression accessories could cause Corona in environments greater than or equal to 345 kV. Pads with edges and corners rounded can be supplied by adding the catalog suffix "EHV".

Ordering Instructions

Step 1: Assembly Catalog Number

Determine the assembly catalog number based on the conductor being used.

Step 2: Terminal Connector

For an assembly without a terminal connector, use 'NT'.
For an assembly with a terminal connector, leave blank.

Step 3: Extra High Voltage Finish

For Extra High Voltage Finish, use 'EHV'.
For Standard Finish, leave blank.

Step 4: Assemble Catalog Number.



Example:

For 795 Arbutus conductor with no terminal and EHV finish, the complete catalog number is:

C43317NTEHV

Notes:

1. Adjustable Clevis Dimensions are on page 120.
2. Pad Dimensions are on page 117.
3. AFL Filler Compound (AFC) Requirements are on page 115.
4. Installation Instructions for Dead Ends are on page 133.
5. Installation Instructions for Terminals are on page 131.

Compression Dead Ends—43300 Series for AAC Conductor, Adjustable Clevis Type, Double Tongue (cont.)

DEAD END ASSEMBLY CATALOG NUMBER	CODE WORD	CONDUCTOR			ALUMINUM BODY DOUBLE TONGUE	ADJUSTABLE STEEL CLEVIS	15° TERMINAL CONNECTOR	DIE SIZE	TOTAL WEIGHT		DIMENSION L		PAD SIZE
		SIZE	STRANDING	DIA.					ALUMINUM HEX DIE	LBS	KG	IN	
		KCMIL	AL	IN									
C43310	Daffodil	350.0	19	0.681	7220.719	C6100	5120.719	20AH	6.5	2.94	24.3	616	B
C43310	Gardenia	350.0	37	0.681	7220.719	C6100	5120.719	20AH	6.5	2.94	24.3	616	B
C43311	Canna	397.5	19	0.724	7220.812	C6100	5120.812	20AH	6.4	2.89	24.3	616	B
C43311	Goldentuft	450.0	19	0.772	7220.812	C6100	5120.812	20AH	6.4	2.89	24.3	616	B
C43311	Yarrow	450.0	37	0.772	7220.812	C6100	5120.812	20AH	6.4	2.89	24.3	616	B
C43311	Cosmos	477.0	19	0.795	7220.812	C6100	5120.812	20AH	6.4	2.89	24.3	616	B
C43311	Syringa	477.0	37	0.795	7224.875	C6100	5120.875	24AH	7.7	3.49	25.0	635	B
C43312	Cosmos	477.0	19	0.795	7224.875	C6100	5124.875	24AH	7.7	3.49	25.0	635	B
C43312	Syringa	477.0	37	0.795	7220.875	C6100	5124.875	24AH	7.7	3.49	25.0	635	B
C43312	Zinna	500.0	19	0.813	7224.875	C6100	5124.875	24AH	7.7	3.49	25.0	635	B
C43312	Hyacinth	500.0	37	0.813	7224.875	C6100	5124.875	24AH	8.1	3.68	25.1	638	B
C43313	Dahlia	556.5	19	0.858	7224.938C	C6200	5124.938	24AH	8.1	3.68	25.1	638	B
C43313	Mistletoe	556.5	37	0.858	7224.938C	C6200	5124.938	24AH	8.1	3.68	25.1	638	B
C43313	Meadowsweet	600.0	37	0.891	7224.938C	C6200	5124.938	24AH	8.1	3.68	25.1	638	B
C43314	Lotus	600.0	61	0.893	7224.938C	C6200	5124.938	24AH	8.0	3.63	25.1	638	B
C43314	Orchid	636.0	37	0.918	7224.969C	C6200	5124.969	24AH	8.0	3.63	25.1	638	B
C43314	Heuchera	650.0	37	0.928	7224.969C	C6200	5124.969	24AH	8.0	3.63	25.1	638	B
C43315	Verbena	700.0	37	0.963	7227.100	C6200	5127.100	27AH	10.2	4.63	27.4	695	D
C43316	Violet	715.5	37	0.975	7227.106	C6200	5127.106	27AH	10.1	4.58	27.4	695	D
C43316	Nasurtium	715.5	61	0.975	7227.106	C6200	5127.106	27AH	10.1	4.58	27.4	695	D
C43316	Petunia	750.0	37	0.998	7227.106	C6200	5127.106	27AH	10.1	4.58	27.4	695	D
C43316	Cattail	750.0	61	0.998	7227.106	C6200	5127.106	27AH	10.1	4.58	27.4	695	D
C43317	Arbutus	795.0	37	1.028	7230.109	C6300	5130.109	30AH	15.2	6.89	29.8	757	D
C43317	Lilac	795.0	61	1.028	7230.109	C6300	5130.109	30AH	15.2	6.89	29.8	757	D
C43317	—	800.0	37	1.031	7230.109	C6300	5130.109	30AH	15.2	6.89	29.8	757	D
C43317	Heliotrope	800.0	61	1.031	7230.109	C6300	5130.109	30AH	15.2	6.89	29.8	757	D
C43318	Cockscomb	900.0	37	1.094	7230.116	C6300	5130.116	30AH	15.3	6.94	30.8	783	D
C43318	Snapdragon	900.0	61	1.094	7230.116	C6300	5130.116	30AH	15.3	6.94	30.8	783	D
C43319	Magnolia	954.0	37	1.126	7230.122	C6400	5130.122	30AH	15.8	7.26	32.2	818	D
C43319	Goldenrod	954.0	61	1.126	7230.122	C6400	5130.122	30AH	15.8	7.26	32.2	818	D
C43319	Hawkweed	1000.0	37	1.152	7230.122	C6400	5130.122	30AH	15.0	7.26	32.2	818	D
C43319	Camellia	1000.0	61	1.152	7230.122	C6400	5130.122	30AH	15.0	7.26	32.2	818	D
C43319	Bluebell	1033.5	37	1.172	7230.122	C6400	5130.122	30AH	16.0	7.26	32.2	818	D
C43319	Larkspur	1033.5	61	1.172	7230.122	C6400	5130.122	30AH	16.0	7.26	32.2	818	D
C43320	Marigold	1113.0	61	1.216	7234.128	C6400	5134.128	34AH	18.1	8.21	32.0	813	D
C43321	Hawthorn	1192.5	61	1.258	7234.134	C6400	5134.134	34AH	17.8	8.08	32.4	824	D
C43321	Narcissus	1272.0	61	1.300	7234.134	C6400	5134.134	34AH	17.8	8.08	32.4	824	D
C43322	Columbine	1351.5	61	1.340	7236.144	C6500	5136.144	36AH	19.5	8.84	33.4	848	D
C43322	Carnation	1431.0	61	1.379	7236.144	C6500	5136.144	36AH	19.5	8.84	33.4	848	D
C43323	—	1500.0	91	1.412	7236.147	C6500	5136.147	36AH	19.4	8.79	33.4	848	D

Compression Dead Ends—43300 Series for AAC Conductor, Adjustable Clevis Type, Double Tongue (cont.)

DEAD END ASSEMBLY CATALOG NUMBER	CODE WORD	CONDUCTOR			ALUMINUM BODY DOUBLE TONGUE	ADJUSTABLE STEEL CLEVIS	15° TERMINAL CONNECTOR	DIE SIZE	TOTAL WEIGHT		DIMENSION L		PAD SIZE
		SIZE	STRANDING	DIA.					ALUMINUM HEX DIE	LBS	KG	IN	
		KCMIL	AL	IN									
C43323	Gladiolus	1510.5	61	1.417	7236.147	C6500	5136.147	36AH	19.4	8.79	33.4	848	D
C43324	Coreopsis	1590.0	61	1.454	7238.156	C6500	5138.156	38AH	20.5	9.30	33.6	854	D
C43324	Dogwood	1590.0	91	1.454	7238.156	C6500	5138.156	38AH	20.5	9.30	33.6	854	D
C43325	Jessamine	1750.0	61	1.525	7240.162	C6600	5140.162	40AH	28.1	12.75	36.2	919	E
C43326	Cowslip	2000.0	91	1.630	7242.178C	C6700	5142.178	42AH	29.5	13.39	37.6	954	E
C43327	Sagebrush	2250.0	91	1.729	7244.181	C6700	5144.181	44AH	31.7	14.38	37.1	943	E
C43327	—	2300.0	61	1.750	7244.181	C6700	5144.181	44AH	31.5	14.38	37.1	943	E
C43327	—	2300.0	91	1.750	7244.181	C6700	5144.181	44AH	31.5	14.38	37.1	943	E
C43328	Lupine	2500.0	91	1.823	7244.188	C6700	5144.188	44AH	31.2	14.15	37.1	943	E
C43329	Bitterroot	2750.0	91	1.912	7248.197	C6800	5148.197	48AH	42.4	19.24	40.4	1027	E

Compression Joints—7000 Series for AAC Conductors

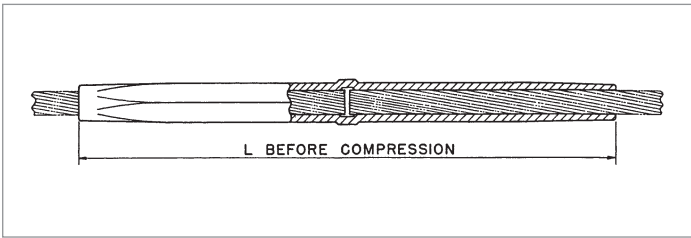

The 7000 Series Compression Joint is specifically designed for AAC conductors. The aluminum joint is fabricated from AFL seamless drawn aluminum.

All compression joints are designed for full tension use, achieving a minimum of 95% of the ASTM rated strength of the conductor on which they are used.

For die size sections 30AH and above, the end tapers of the compression portions of all compression accessories are supplied with a high voltage finish.

Ordering Instructions

Step 1: Assembly Catalog Number

Determine the assembly catalog number based on the conductor being used.

Example:

For 795 Arbutus Conductor, the complete catalog number is:

7030.109

ALUMINUM JOINT CATALOG NUMBER	CONDUCTOR				DIE SIZE	WEIGHT		DIMENSION L	
	CODE WORD	AWG OR KCMIL	STRANDING	DIA.	ALUMINUM HEX DIE	LBS	KG	IN	MM
			AL	IN					
7071.219	Peachbell	6	7	0.184	71AH	0.1	0.02	4.5	114
7071.250	Rose	4	7	0.232	71AH	0.1	0.02	5.0	127
7072.312	Iris	2	7	0.292	72AH	0.1	0.06	6.6	168
7073.391	Poppy	1/0	7	0.368	73AH	0.2	0.07	8.4	213
7074.438	Aster	2/0	7	0.414	74AH	0.4	0.17	10.1	257
7074.484	Phlox	3/0	7	0.464	74AH	0.4	0.16	10.1	257
7075.547	Oxlip	4/0	7	0.522	75AH	0.6	0.29	11.9	302
7075.609	Valerian	250.0	19	0.575	75AH	0.6	0.26	11.9	302
7075.609	Laurel	266.8	19	0.593	75AH	0.6	0.26	11.9	302
7076.656	Peony	300.0	19	0.629	76AH	1.0	0.45	15.1	384
7076.688	Tulip	336.4	19	0.666	76AH	1.0	0.44	15.1	384
7020.719	Daffodil	350.0	19	0.681	20AH	1.2	0.54	15.0	381
7076.750	Canna	397.5	19	0.724	76AH	0.9	0.40	15.1	384
7020.812	Goldentuft	450.0	19	0.772	20AH	1.0	0.45	15.0	381
7020.812	Yarrow	450.0	37	0.772	20AH	1.0	0.45	15.0	381
7020.812	Cosmos	477.0	19	0.793	20AH	1.0	0.45	15.0	381
7024.875	Syringa	477.0	37	0.795	24AH	1.8	0.82	16.0	406
7024.875	Zinna	500.0	19	0.811	24AH	1.8	0.82	16.0	406

Notes:

1. AFL Filler Compound (AFC) Requirements are on page 115.
2. Installation Instructions for Joints are on page 137.

Compression Joints—7000 Series for AAC Conductors (cont.)

ALUMINUM JOINT CATALOG NUMBER	CONDUCTOR				DIE SIZE ALUMINUM HEX DIE	WEIGHT		DIMENSION L	
	CODE WORD	AWG OR KCMIL	STRANDING	DIA.		LBS	KG	IN	MM
			AL	IN					
7024.875	Hyacinth	500.0	37	0.813	24AH	1.8	0.82	16.0	406
7024.938	Dahlia	556.5	19	0.856	24AH	1.6	0.73	16.0	406
7024.938	Mistletoe	556.5	37	0.858	24AH	1.6	0.73	16.0	406
7024.938	Meadowsweet	600.0	37	0.891	24AH	1.6	0.73	16.0	406
7024.969	Orchid	636.0	37	0.918	24AH	1.5	0.68	16.0	406
7024.969	Heuchera	650.0	37	0.928	24AH	1.5	0.68	16.0	406
7027.100	Flag	700.0	61	0.964	27AH	2.7	1.22	20.0	508
7027.106	Violet	715.5	37	0.974	27AH	2.5	1.13	20.0	508
7027.106	Nasurtium	715.5	61	0.975	27AH	2.5	1.13	20.0	508
7027.106	Petunia	750.0	37	0.997	27AH	2.5	1.13	20.0	508
7027.106	Cattail	750.0	61	0.998	27AH	2.5	1.13	20.0	508
7030.109	Arbutus	795.0	37	1.026	30AH	3.5	1.59	20.0	508
7030.109	Lilac	795.0	61	1.028	30AH	3.5	1.59	20.0	508
7030.109	—	800.0	37	1.031	30AH	3.5	1.59	20.0	508
7030.109	Heliotrope	800.0	61	1.031	30AH	3.5	1.59	20.0	508
7030.116	Snapdragon	900.0	61	1.094	30AH	3.4	1.54	22.0	559
7030.122	Magnolia	954.0	37	1.124	30AH	3.5	1.59	24.5	622
7030.122	Goldenrod	954.0	61	1.126	30AH	3.5	1.59	24.5	622
7030.122	Camellia	1000.0	61	1.152	30AH	3.5	1.59	24.5	622
7030.122	Bluebell	1033.5	37	1.170	30AH	3.5	1.59	24.5	622
7030.122	Larkspur	1033.5	61	1.172	30AH	3.5	1.59	24.5	622
7034.128	Marigold	1113.0	61	1.216	34AH	5.4	2.45	24.0	610
7034.134	Hawthorn	1192.5	61	1.258	34AH	5.3	2.40	25.0	635
7034.134	Narcissus	1272.0	61	1.300	34AH	5.3	2.40	25.0	635
7036.144	Columbine	1351.5	61	1.340	36AH	6.0	2.72	27.0	686
7036.144	Carnation	1431.0	61	1.379	36AH	6.0	2.72	27.0	686
7036.147	—	1500.0	91	1.412	36AH	5.8	2.63	27.0	686
7036.147	Gladiolus	1510.5	61	1.417	36AH	5.8	2.63	27.0	686
7038.156	Coreopsis	1590.0	61	1.454	38AH	6.3	2.86	27.0	686
7038.156	Dogwood	1590.0	91	1.454	38AH	6.3	2.86	27.0	686
7040.162	Jessamine	1750.0	61	1.525	40AH	7.3	3.31	27.0	686
7042.178	Cowslip	2000.0	91	1.630	42AH	8.9	4.04	29.0	737
7044.181	Sagebrush	2250.0	91	1.729	44AH	8.9	4.04	28.4	721
7044.181	—	2300.0	61	1.750	44AH	8.9	4.04	28.4	721
7044.181	—	2300.0	91	1.750	44AH	8.9	4.04	28.4	721
7044.188	Lupine	2500.0	91	1.823	44AH	8.4	3.81	28.4	721
7048.197	Bitterroot	2750.0	91	1.912	48AH	12.7	5.76	33.5	851

Repair Sleeves—5200 Series for AAC Conductors

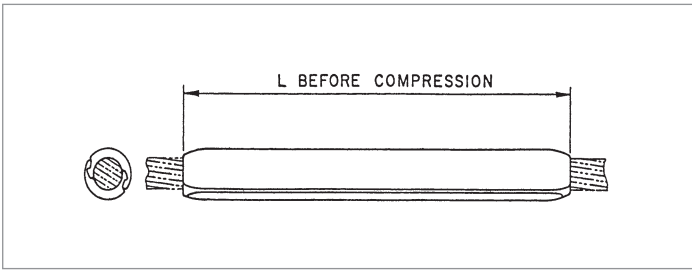

Ordering Instructions

Step 1: Assembly Catalog Number

Determine the assembly catalog number based on the conductor being used.

Example:

For 795 Arbutus conductor, the complete catalog number is:

5230.3

The 5200 Series Repair Sleeve is designed for AAC conductors. The repair sleeve incorporates an improved design of interlocking extrusions, providing a permanent grip on the conductor when compressed.

The repair sleeve will restore 95% of the rated strength of the conductor with up to one-third of the aluminum strands damaged.

REPAIR SLEEVE AFL NO.	CONDUCTOR				DIE SIZE ALUMINUM HEX DIE	WEIGHT		DIMENSION L	
	CODE NAME	SIZE	STRANDING	DIA.		LBS	KG	IN	MM
		KCMIL/AWG	AL	IN					
5274	Aster	2/0	7	0.414	74AH	0.2	0.10	7.6	192
5274	Phlox	3/0	7	0.464	74AH	0.2	0.10	7.6	192
5275	Oxlip	4/0	7	0.522	75AH	0.4	0.18	8.6	217
5275	Valerian	250.0	19	0.575	75AH	0.4	0.18	8.6	217
5275	Laurel	266.8	19	0.593	75AH	0.4	0.18	8.6	217
5276	Peony	300.0	19	0.629	76AH	0.7	0.30	10.0	254
5276	Tulip	336.4	19	0.666	76AH	0.7	0.30	10.0	254
5276	Daffodil	350.0	19	0.679	76AH	0.7	0.30	10.0	254
5276	Canna	397.5	19	0.724	76AH	0.7	0.30	10.0	254
5220.3	Goldentuft	450.0	19	0.770	20AH	1.0	0.45	14.5	368
5220.3	Yarrow	450.0	37	0.772	20AH	1.0	0.45	14.5	368
5220.3	Cosmos	477.0	19	0.793	20AH	1.0	0.45	14.5	368
5224.3	Syringa	477.0	37	0.795	24AH	1.7	0.77	15.5	394
5224.3	Cosmos	477.0	19	0.793	24AH	1.7	0.77	15.5	394
5224.3	Syringa	477.0	37	0.795	24AH	1.7	0.77	15.5	394
5224.3	Zinnia	500.0	19	0.811	24AH	1.7	0.77	15.5	394
5224.3	Hyacinth	500.0	37	0.813	24AH	1.7	0.77	15.5	394
5224.3	Dahlia	556.5	19	0.856	24AH	1.7	0.77	15.5	394
5224.3	Mistletoe	556.5	387	0.858	24AH	1.7	0.77	15.5	394
5224.3	Meadowsweet	600.0	37	0.891	24AH	1.7	0.77	15.5	394
5224.3	Orchid	636.0	37	0.918	24AH	1.7	0.77	15.5	394

Notes:

1. AFL Filler Compound (AFC) Requirements are on page 115.
2. Installation Instructions for Repair Sleeves are on page 142.

Repair Sleeves—5200 Series for AAC Conductors (cont.)

REPAIR SLEEVE AFL NO.	CONDUCTOR				DIE SIZE		WEIGHT		DIMENSION L	
	CODE NAME	SIZE	STRANDING	DIA.	ALUMINUM HEX DIE	LBS	KG	IN	MM	
		KCMIL/AWG	AL	IN						
5227.3	Heuchera	650.0	37	0.928	27AH	2.6	1.18	18.3	464	
5227.3	Flag	700.0	61	0.964	27AH	2.6	1.18	18.3	464	
5227.3	Violet	715.5	37	0.974	27AH	2.6	1.18	18.3	464	
5227.3	Nasturtium	715.5	61	0.975	27AH	2.6	1.18	18.3	464	
5227.3	Petunia	750.0	37	0.997	27AH	2.6	1.18	18.3	464	
5227.3	Cattail	750.0	61	0.998	27AH	2.6	1.18	18.3	464	
5230.3	Arbutus	795.0	37	1.026	30AH	3.0	1.36	19.1	486	
5230.3	Lilac	795.0	61	1.028	30AH	3.0	1.36	19.1	486	
5230.3	—	800.0	37	1.031	30AH	3.0	1.36	19.1	486	
5230.3	Heliotrope	800.0	61	1.031	30AH	3.0	1.36	19.1	486	
5230.3	Snapdragon	900.0	61	1.094	30AH	3.0	1.36	19.1	486	
5230.3	Magnolia	954.0	37	1.124	30AH	3.0	1.36	19.1	486	
5230.3	Goldenrod	954.0	61	1.126	30AH	3.0	1.36	19.1	486	
5230.3	Camellia	1000.0	61	1.152	30AH	3.0	1.36	19.1	486	
5230.3	Bluebell	1033.5	37	1.170	30AH	3.0	1.36	19.1	486	
5230.3	Larkspur	1033.5	61	1.172	30AH	3.0	1.36	19.1	486	
5234.3	Marigold	1113.0	61	1.216	34AH	4.2	1.91	20.1	511	
5234.3	Hawthorn	1192.5	61	1.258	34AH	4.2	1.91	20.1	511	
5234.3	Narcissus	1272.0	61	1.300	34AH	4.2	1.91	20.1	511	
5236.3	Columbine	1351.0	61	1.340	36AH	4.4	2.00	21.0	533	
5236.3	Carnation	1431.0	61	1.379	36AH	4.4	2.00	21.0	533	
5236.3	—	1500.0	91	1.412	36AH	4.4	2.00	21.0	533	
5236.3	Gladiolus	1510.5	61	1.416	36AH	4.4	2.00	21.0	533	
5238.3	Coreopsis	1590.0	61	1.453	38AH	5.2	2.36	21.9	556	
5238.3	Dogwood	1590.0	91	1.454	38AH	5.2	2.36	21.9	556	
5240.3	Jessamine	1750.0	61	1.525	40AH	6.1	2.77	22.8	578	
5242.3	Cowslip	2000.0	91	1.630	42AH	6.8	3.08	23.6	600	
5244.3	Sagebrush	2250.0	91	1.729	44AH	8.7	3.95	24.5	622	
5244.3	—	2300.0	61	1.750	44AH	8.7	3.95	24.5	622	
5244.3	—	2300.0	91	1.750	44AH	8.7	3.95	24.5	622	
5244.3	Lupine	2500.0	91	1.823	44AH	8.7	3.95	24.5	622	
5248.3	Bitterroot	2750.0	91	1.912	48AH	9.1	4.13	24.5	622	

Jumper Connectors—5000 Series for AAC Conductors

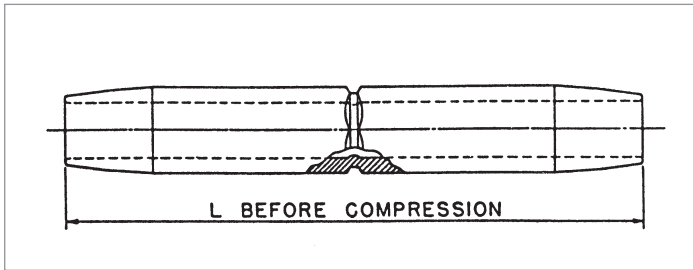

Ordering Instructions

Step 1: Assembly Catalog Number

Determine the assembly catalog number based on the conductor being used.

Example:

For 795 Arbutus conductor, the complete catalog number is:

5030.109

The 5000 Series Jumper Connector is designed for AAC conductors. The jumper connector is fabricated from AFL seamless drawn aluminum. All jumper connectors are designed for limited tension use, maintaining a minimum of 40% of the ASTM rated strength of the conductor on which it is being used.

For die size sections 30AH and above, the end tapers of the compression portions of all compression accessories are supplied with a high voltage finish.

JUMPER CONNECTOR CATALOG NUMBER	CONDUCTOR				DIE SIZE ALUMINUM HEX DIE	WEIGHT		DIMENSION L	
	CODE NAME	SIZE	STRANDING	DIA.		LBS	KG	IN	MM
		KCMIL	AL	IN					
5071.219	Peachbell	6.0	7	0.184	71AH	0.1	0.03	4.0	102
5071.250	Rose	4.0	7	0.232	71AH	0.1	0.02	4.0	102
5072.312	Iris	2.0	7	0.292	72AH	0.1	0.04	4.5	114
5073.391	Poppy	1/0	7	0.368	73AH	0.1	0.05	6.0	152
5074.438	Aster	2/0	7	0.414	74AH	0.3	0.11	7.0	178
5074.484	Phlox	3/0	7	0.464	74AH	0.2	0.10	7.0	178
5075.547	Oxlip	4/0	7	0.522	75AH	0.4	0.18	8.0	203
5075.609	Valerian	250.0	19	0.575	75AH	0.4	0.18	8.0	203
5075.609	Laurel	266.8	19	0.593	75AH	0.4	0.18	8.0	203
5076.656	Peony	300.0	19	0.629	76AH	0.7	0.31	9.0	229
5076.688	Tulip	336.4	19	0.666	76AH	0.7	0.29	9.0	229
5076.719	Daffodil	350.0	19	0.679	76AH	0.6	0.28	9.0	229
5076.750	Canna	397.5	19	0.724	76AH	0.6	0.27	9.0	229
5020.812	Goldentuft	450.0	19	0.770	20AH	0.7	0.31	10.0	254
5020.812	Yarrow	450.0	37	0.772	20AH	0.7	0.31	10.0	254
5020.812	Cosmos	477.0	19	0.793	20AH	0.7	0.31	10.0	254
5020.812	Syringa	477.0	37	0.795	20AH	0.7	0.31	10.0	254
5024.875	Cosmos	477.0	19	0.793	24AH	1.2	0.54	11.0	279

Notes:

1. AFL Filler Compound (AFC) Requirements are on page 115.
2. Installation Instructions for Jumper Connectors are on page 143.

Jumper Connectors—5000 Series for AAC Conductors (cont.)

JUMPER CONNECTOR CATALOG NUMBER	CONDUCTOR				DIE SIZE ALUMINUM HEX DIE	WEIGHT		DIMENSION L	
	CODE NAME	SIZE	STRANDING	DIA.		LBS	KG	IN	MM
		KCMIL	AL	IN					
5024.875	Syringa	477.0	37	0.795	24AH	1.2	0.54	11.0	279
5024.875	Zinnia	500.0	19	0.811	24AH	1.2	0.54	11.0	279
5024.875	Hyacinth	500.0	37	0.813	24AH	1.2	0.54	11.0	279
5024.938	Dahlia	556.5	19	0.856	24AH	1.1	0.50	11.0	279
5024.938	Mistletoe	556.5	37	0.858	24AH	1.1	0.50	11.0	279
5024.938	Meadowsweet	600.0	37	0.891	24AH	1.1	0.50	11.0	279
5024.969	Orchid	636.0	37	0.918	24AH	1.0	0.45	11.0	279
5024.969	Heuchera	650.0	37	0.928	24AH	1.0	0.45	11.0	279
5027.100	Flag	700.0	61	0.964	27AH	1.6	0.73	12.0	305
5027.106	Violet	715.5	37	0.974	27AH	1.5	0.68	12.0	305
5027.106	Nasturtium	715.5	61	0.975	27AH	1.5	0.68	12.0	305
5027.106	Petunia	750.0	37	0.997	27AH	1.5	0.68	12.0	305
5027.106	Cattail	750.0	61	0.998	27AH	1.5	0.68	12.0	305
5030.109	Arbutus	795.0	37	1.026	30AH	2.1	0.95	13.0	330
5030.109	Lilac	795.0	61	1.028	30AH	2.1	0.95	13.0	330
5030.109	—	800.0	37	1.031	30AH	2.1	0.95	13.0	330
5030.109	Heliotrope	800.0	61	1.031	30AH	2.1	0.95	13.0	330
5030.116	Snapdragon	900.0	61	1.094	30AH	2.0	0.91	13.0	330
5030.122	Magnolia	954.0	37	1.124	30AH	1.8	0.82	13.0	330
5030.122	Goldenrod	954.0	61	1.126	30AH	1.8	0.82	13.0	330
5030.122	Camellia	1000.0	61	1.152	30AH	1.8	0.82	13.0	330
5030.122	Bluebell	1033.5	37	1.170	30AH	1.8	0.82	13.0	330
5030.122	Larkspur	1033.5	61	1.172	30AH	1.8	0.82	13.0	330
5034.128	Marigold	1113.0	61	1.216	34AH	2.8	1.27	14.0	358
5034.134	Hawthorn	1192.5	61	1.258	34AH	2.6	1.18	14.0	358
5034.134	Narcissus	1272.0	61	1.300	34AH	2.6	1.18	14.0	358
5036.144	Columbine	1351.0	61	1.340	36AH	3.2	1.45	15.0	381
5036.144	Carnation	1431.0	61	1.379	36AH	3.2	1.45	15.0	381
5036.147	—	1500.0	91	1.412	36AH	3.1	1.41	15.0	381
5036.147	Gladiolus	1510.5	61	1.416	36AH	3.1	1.41	15.0	381
5038.156	Coreopsis	1590.0	61	1.453	38AH	3.8	1.72	16.0	406
5038.156	Dogwood	1590.0	91	1.454	38AH	3.8	1.72	16.0	406
5040.162	Jessamine	1750.0	61	1.525	40AH	4.5	2.04	17.0	432
5042.178	Cowslip	2000.0	91	1.630	42AH	4.6	2.09	17.0	432
5044.181	Sagebrush	2250.0	91	1.729	44AH	5.4	2.45	17.0	432
5044.181	—	2250.0	61	1.750	44AH	5.4	2.45	17.0	432
5044.181	—	2300.0	91	1.750	44AH	5.4	2.45	17.0	432
5044.188	Lupine	2500.0	91	1.823	44AH	5.0	2.27	17.0	432
5048.197	Bitterroot	2750.0	91	1.912	48AH	7.3	3.31	19.0	483

Terminal Connectors—5600 Series for AAC Conductors, Straight

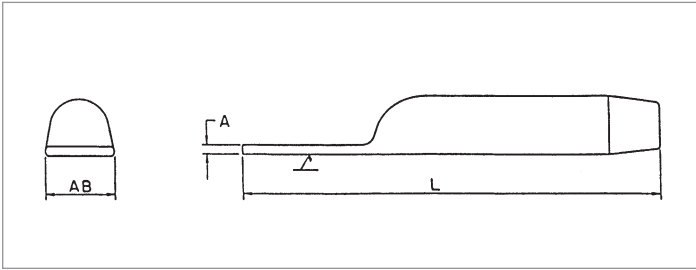

The 5600 Series Straight Terminal Connector is designed for AAC conductors. The terminal connector is fabricated from AFL seamless drawn aluminum.

When used with the dead end, the straight terminal connector allows drop at a 15° angle. All terminal connectors are designed for limited tension use, maintaining a minimum of 40% of the ASTM rated strength of the conductor on which it is being used.

Ordering Instructions

Step 1: Assembly Catalog Number

Determine the assembly catalog number based on the conductor being used.

Step 2: Extra High Voltage Finish

For Extra High Voltage Finish, use 'EHV'.

For Standard Finish, leave blank.

Step 3: Assemble Catalog Number.

Assy Catalog Number + **EHV Finish**

Example:

For 795 Arbutus conductor with an EHV finish, the complete catalog number is:

5630.109EHV

TERMINAL CATALOG NUMBER	CODE WORD	CONDUCTOR			DIE SIZE	TOTAL WEIGHT		DIMENSION						PAD SIZE
		SIZE	STRANDING	DIA.	ALUMINUM			L		A		AB		
		KCMIL	AL	IN	HEX DIE	LBS	KG	IN	MM	IN	MM	IN	MM	
5673.391	Poppy	1/0	7	0.368	73AH	0.1	0.06	7.6	194	0.2	5	1.0	25	B
5674.438	Aster	2/0	7	0.414	74AH	0.3	0.14	8.3	211	0.3	9	1.0	25	B
5674.484	Phlox	3/0	7	0.464	74AH	0.3	0.12	8.3	211	0.3	8	1.0	25	B
5675.547	Oxlip	4/0	7	0.522	75AH	0.5	0.23	9.5	241	0.5	13	1.0	25	B
5675.609	Valerian	250.0	19	0.575	75AH	0.5	0.20	9.8	248	0.5	12	1.0	25	B
5675.609	Laurel	266.8	19	0.593	75AH	0.5	0.20	9.8	248	0.5	12	1.0	25	B
5676.656	Peony	300.0	19	0.629	76AH	0.8	0.38	10.4	265	0.6	15	1.3	32	B
5676.688	Tulip	336.4	19	0.666	76AH	0.8	0.37	10.6	268	0.6	14	1.3	32	B
5620.719	Daffodil	350.0	19	0.679	20AH	0.9	0.41	10.8	275	0.5	12	1.3	32	B
5676.750	Canna	397.5	19	0.724	76AH	0.7	0.34	10.8	275	0.5	13	1.3	32	B
5620.812	Goldentuft	450.0	19	0.770	20AH	0.8	0.37	12.3	306	0.5	12	1.3	32	B
5620.812	Yarrow	450.0	37	0.772	20AH	0.8	0.37	12.3	306	0.5	12	1.3	32	B
5620.812	Cosmos	477.0	19	0.793	20AH	0.8	0.37	12.3	306	0.5	12	1.3	32	B
5620.812	Syringa	477.0	37	0.795	20AH	0.8	0.37	12.3	306	0.5	12	1.3	32	B
5624.875	Cosmos	477.0	19	0.793	24AH	1.4	0.64	12.6	319	0.6	16	1.5	38	B
5624.875	Syringa	477.0	37	0.795	24AH	1.4	0.64	12.6	319	0.6	16	1.5	38	B
5624.875	Zinnia	500.0	19	0.811	24AH	1.4	0.64	12.6	319	0.6	16	1.5	38	B

Notes:

1. Pad Dimensions are on page 117.
2. AFL Filler Compound (AFC) Requirements are on page 117.
3. Installation Instructions for Terminals are on page 131.
4. Bolts, nuts and washers are not supplied with the straight terminal connector.

Terminal Connectors—5600 Series for AAC Conductors, Straight (cont.)

TERMINAL CATALOG NUMBER	CODE WORD	CONDUCTOR			DIE SIZE	TOTAL WEIGHT		DIMENSION						PAD SIZE
		SIZE	STRANDING	DIA.	ALUMINUM	LBS	KG	L		A		AB		
		KCMIL	AL	IN	HEX DIE			IN	MM	IN	MM	IN	MM	
5624.875	Hyacinth	500.0	37	0.813	24AH	1.4	0.64	12.6	319	0.6	16	1.5	38	B
5624.938	Dahlia	556.5	19	0.856	24AH	1.3	0.59	12.8	324	0.6	15	1.5	38	B
5624.938	Mistletoe	556.5	387	0.858	24AH	1.3	0.59	12.8	324	0.6	15	1.5	38	B
5624.938	Meadowsweet	600.0	37	0.891	24AH	1.3	0.59	12.8	324	0.6	15	1.5	38	B
5624.969	Orchid	636.0	37	0.918	24AH	1.3	0.59	12.8	325	0.6	15	1.5	38	B
5624.969	Heuchera	650.0	37	0.928	24AH	1.3	0.59	12.8	325	0.6	15	1.5	38	B
5627.100	Flag	700.0	61	0.964	27AH	1.7	0.77	12.1	333	0.4	10	3.0	76	D
5627.106	Violet	715.5	37	0.974	27AH	1.7	0.77	12.1	333	0.4	10	3.0	76	D
5627.106	Nasturtium	715.5	61	0.975	27AH	1.7	0.77	12.1	333	0.4	10	3.0	76	D
5627.106	Petunia	750.0	37	0.997	27AH	1.7	0.77	12.1	333	0.4	10	3.0	76	D
5627.106	Cattail	750.0	61	0.998	27AH	1.7	0.77	12.1	333	0.4	10	3.0	76	D
5630.109	Arbutus	795.0	37	1.026	30AH	2.4	1.09	14.3	363	0.5	13	3.0	76	D
5630.109	Lilac	795.0	61	1.028	30AH	2.4	1.09	14.3	363	0.5	13	3.0	76	D
5630.109	—	800.0	37	1.031	30AH	2.4	1.09	14.3	363	0.5	13	3.0	76	D
5630.109	Heliotrope	800.0	61	1.031	30AH	2.4	1.09	14.3	363	0.5	13	3.0	76	D
5630.116	Snapdragon	900.0	61	1.094	30AH	2.3	1.04	14.6	370	0.5	12	3.0	76	D
5630.122	Magnolia	954.0	37	1.124	30AH	2.2	1.00	14.8	375	0.4	10	3.0	76	D
5630.122	Goldenrod	954.0	61	1.126	30AH	2.2	1.00	14.8	375	0.4	10	3.0	76	D
5630.122	Camellia	1000.0	61	1.152	30AH	2.2	1.00	14.8	375	0.4	10	3.0	76	D
5630.122	Bluebell	1033.5	37	1.170	30AH	2.2	1.00	14.8	375	0.4	10	3.0	76	D
5630.122	Larkspur	1033.5	61	1.172	30AH	2.2	1.00	14.8	375	0.4	10	3.0	76	D
5634.128	Marigold	1113.0	61	1.216	34AH	3.3	1.50	15.3	389	0.6	16	3.0	76	D
5634.134	Hawthorn	1192.5	61	1.258	34AH	3.2	1.45	15.8	4	0.6	15	3.0	76	D
5634.134	Narcissus	1272.0	61	1.300	34AH	3.2	1.45	15.8	4	0.6	15	3.0	76	D
5636.144	Columbine	1351.0	61	1.340	36AH	3.6	1.63	16.6	421	0.6	15	3.0	76	D
5636.144	Carnation	1431.0	61	1.379	36AH	3.6	1.63	16.6	421	0.6	15	3.0	76	D
5636.147	—	1500.0	91	1.412	36AH	3.5	1.59	16.1	409	0.6	16	3.0	76	D
5636.147	Gladiolus	1510.5	61	1.416	36AH	3.5	1.59	16.1	409	0.6	16	3.0	76	D
5638.156	Coreopsis	1590.0	61	1.453	38AH	4.2	1.91	17.9	454	0.7	17	3.0	76	D
5638.156	Dogwood	1590.0	91	1.454	38AH	4.2	1.91	17.9	454	0.7	17	3.0	76	D
5640.162	Jessamine	1750.0	61	1.525	40AH	4.8	2.18	17.6	446	0.7	17	3.0	76	D
5642.178	Cowslip	2000.0	91	1.630	42AH	5.3	2.40	19.0	483	0.7	17	4.0	102	E
5644.181	Sagebrush	2250.0	91	1.729	44AH	6.3	2.86	19.5	493	0.7	18	4.0	102	E
5644.181	—	2300.0	61	1.750	44AH	6.3	2.86	19.5	493	0.7	18	4.0	102	E
5644.181	—	2300.0	91	1.750	44AH	6.3	2.86	19.5	493	0.7	18	4.0	102	E
5644.188	Lupine	2500.0	91	1.823	44AH	6.1	2.77	19.6	498	0.7	18	4.0	102	E
5648.197	Bitterroot	2750.0	91	1.912	48AH	8.2	3.72	21.6	549	0.8	21	4.0	102	E

Terminal Connectors—5100 Series for AAC Conductors, 15°

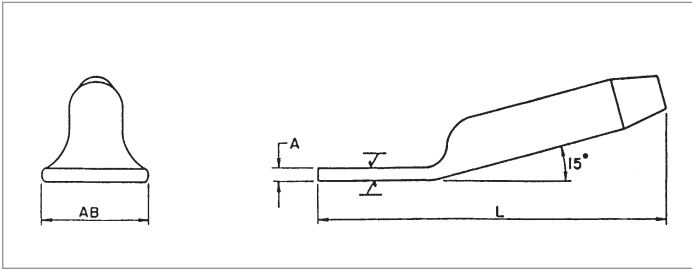

The 5100 Series 15° Terminal Connector is designed for AAC conductors. The terminal connector is fabricated from AFL seamless drawn aluminum.

When used with the dead end, the 15° terminal connector can be bolted in either the straight or 30° position. All terminal connectors are designed for limited tension use, maintaining a minimum of 40% of the ASTM rated strength of the conductor on which it is being used. Aluminum hardware is supplied with the 15° terminal connector.

Ordering Instructions

Step 1: Assembly Catalog Number

Determine the assembly catalog number based on the conductor being used.

Step 2: Extra High Voltage Finish

For Extra High Voltage Finish, use 'EHV'.
For Standard Finish, leave blank.

Step 3: Assemble Catalog Number.



Example:

For 795 Arbutus conductor with an EHV finish, the complete catalog number is:

5130.109EHV

TERMINAL CATALOG NUMBER	CODE WORD	CONDUCTOR			DIE SIZE	TOTAL WEIGHT		DIMENSION						PAD SIZE
		SIZE	STRANDING	DIA.	ALUMINUM			L		A		AB		
		KCMIL	AL	IN	HEX DIE	LBS	KG	IN	MM	IN	MM	IN	MM	
5173.391	Poppy	1/0	7	0.368	73AH	0.3	0.12	7.6	194	0.2	5	1.0	25	B
5174.438	Aster	2/0	7	0.414	74AH	0.4	0.20	8.3	211	0.3	9	1.0	25	B
5174.438		2/0	19	0.419	74AH	0.4	0.20	8.3	211	0.3	9	1.0	25	B
5174.484	Phlox	3/0	7	0.464	74AH	0.4	0.19	8.3	211	0.3	8	1.0	25	B
5174.484		3/0	19	0.470	74AH	0.4	0.19	8.3	211	0.3	8	1.0	25	B
5175.547	Oxlip	4/0	7	0.522	75AH	0.7	0.29	9.5	241	0.5	13	1.0	25	B
		4/0	19	0.528	75AH	0.7	0.29	9.5	241	0.5	13	1.0	25	B
5175.609	Valerian	250.0	19	0.575	75AH	0.6	0.27	9.8	248	0.5	12	1.0	25	B
5175.609	Daisy	266.8	7	0.586	75AH	0.6	0.27	9.8	248	0.5	12	1.0	25	B
5175.609	Laurel	266.8	19	0.593	75AH	0.6	0.27	9.8	248	0.5	12	1.0	25	B
5176.656	Peony	300.0	19	0.629	76AH	0.9	0.41	10.4	265	0.6	15	1.3	32	B
5176.688	Tulip	336.4	19	0.666	76AH	0.9	0.40	10.6	268	0.6	14	1.3	32	B

Notes:

1. Pad Dimensions are on page 117.
2. AFL Filler Compound (AFC) Requirements are on page 115.
3. Installation Instructions for Terminals are on page 131.
4. Supplied with aluminum hardware.

Terminal Connectors—5100 Series for AAC Conductors, 15° (cont.)

TERMINAL CATALOG NUMBER	CODE WORD	CONDUCTOR			DIE SIZE		TOTAL WEIGHT		DIMENSION						PAD SIZE
		SIZE	STRANDING	DIA.	ALUMINUM	HEX DIE			L		A		AB		
		KCMIL	AL	IN			IN	MM	IN	MM	IN	MM			
5120.719	Daffodil	350.0	19	0.679	76AH	0.9	0.39	10.7	272	0.5	13	1.3	32	B	
5176.750	Canna	397.5	19	0.724	76AH	0.8	0.38	10.8	275	0.5	13	1.3	32	B	
5120.812	Goldentuft	450.0	19	0.770	20AH	1.0	0.44	12.1	306	0.5	12	1.3	32	B	
5120.812	Yarrow	450.0	37	0.772	20AH	1.0	0.44	12.1	306	0.5	12	1.3	32	B	
5120.812	Cosmos	477.0	19	0.793	20AH	1.0	0.44	12.1	306	0.5	12	1.3	32	B	
5120.812	Syringa	477.0	37	0.795	20AH	1.0	0.44	12.1	306	0.5	12	1.3	32	B	
5124.875	Cosmos	477.0	19	0.793	24AH	1.6	0.73	12.6	319	0.6	16	1.5	38	B	
5124.875	Syringa	477.0	37	0.795	24AH	1.6	0.73	12.6	319	0.6	16	1.5	38	B	
5124.875	Zinnia	500.0	19	0.811	24AH	1.6	0.73	12.6	319	0.6	16	1.5	38	B	
5124.875	Hyacinth	500.0	37	0.813	24AH	1.6	0.73	12.6	319	0.6	16	1.5	38	B	
5124.938	Dahlia	556.5	19	0.856	24AH	1.5	0.68	12.8	324	0.6	15	1.5	38	B	
5124.938	Mistletoe	556.5	37	0.858	24AH	1.5	0.68	12.8	324	0.6	15	1.5	38	B	
5124.938	Meadowsweet	600.0	37	0.891	24AH	1.5	0.68	12.8	324	0.6	15	1.5	38	B	
5124.969	Orchid	636.0	37	0.918	24AH	1.5	0.68	12.8	325	0.6	15	1.5	38	B	
5124.969	Heuchera	650.0	37	0.928	24AH	1.5	0.68	12.8	325	0.6	15	1.5	38	B	
5127.100	Flag	700.0	61	0.964	27AH	1.9	0.86	12.3	313	0.4	10	3.0	76	D	
5127.106	Violet	715.5	37	0.974	27AH	1.9	0.86	12.3	313	0.4	10	3.0	76	D	
5127.106	Nasturtium	715.5	61	0.975	27AH	1.9	0.86	12.3	313	0.4	10	3.0	76	D	
5127.106	Petunia	750.0	37	0.997	27AH	1.9	0.86	12.3	313	0.4	10	3.0	76	D	
5127.106	Cattail	750.0	61	0.998	27AH	1.9	0.86	12.3	313	0.4	10	3.0	76	D	
5130.109	Arbutus	795.0	37	1.026	30AH	2.7	1.22	13.6	346	0.5	13	3.0	76	D	
5130.109	Lilac	795.0	61	1.028	30AH	2.7	1.22	13.6	346	0.5	13	3.0	76	D	
5130.109	—	800.0	37	1.031	30AH	2.7	1.22	13.6	346	0.5	13	3.0	76	D	
5130.109	Heliotrope	800.0	61	1.031	30AH	2.7	1.22	13.6	346	0.5	13	3.0	76	D	
5130.116	Snapdragon	900.0	61	1.094	30AH	2.6	1.18	13.9	354	0.5	12	3.0	76	D	
5130.122	Magnolia	954.0	37	1.124	30AH	2.5	1.13	14.3	362	0.4	10	3.0	46	D	
5130.122	Goldenrod	954.0	61	1.126	30AH	2.5	1.13	14.3	362	0.4	10	3.0	46	D	
5130.122	Camellia	1000.0	61	1.152	30AH	2.5	1.13	14.3	362	0.4	10	3.0	46	D	
5130.122	Bluebell	1033.5	37	1.170	30AH	2.5	1.13	14.3	362	0.4	10	3.0	46	D	
5130.122	Larkspur	1033.5	61	1.172	30AH	2.5	1.13	14.3	362	0.4	10	3.0	46	D	
5134.128	Marigold	1113.0	61	1.216	34AH	3.6	1.63	14.3	363	0.6	16	3.0	76	D	
5134.134	Hawthorn	1192.5	61	1.258	34AH	3.5	1.59	14.5	368	0.6	15	3.0	76	D	
5134.134	Narcissus	1272.0	61	1.300	34AH	3.5	1.59	14.5	368	0.6	15	3.0	76	D	
5136.144	Columbine	1351.0	61	1.340	36AH	3.8	1.72	15.3	389	0.6	15	3.0	76	D	

Terminal Connectors—5100 Series for AAC Conductors, 15° (cont.)

TERMINAL CATALOG NUMBER	CODE WORD	CONDUCTOR			DIE SIZE		TOTAL WEIGHT		DIMENSION						PAD SIZE
		SIZE	STRANDING	DIA.	ALUMINUM	HEX DIE			L		A		AB		
		KCMIL	AL	IN			IN	MM	IN	MM	IN	MM			
5136.144	Carnation	1431.0	61	1.379	36AH	3.8	1.72	15.3	389	0.6	15	3.0	76	D	
5136.147	—	1500.0	91	1.412	36AH	3.8	1.72	15.1	384	0.6	16	3.0	76	D	
5136.147	Gladiolus	1510.5	61	1.416	36AH	3.8	1.72	15.1	384	0.6	16	3.0	76	D	
5138.156	Coreopsis	1590.0	61	1.453	38AH	4.4	2.00	16.9	424	0.9	17	3.0	76	D	
5138.156	Dogwood	1590.0	91	1.454	38AH	4.4	2.00	16.9	424	0.9	17	3.0	76	D	
5140.162	Jessamine	1750.0	61	1.525	40AH	5.3	2.40	17.4	443	0.9	18	4.0	102	E	
5142.178	Cowslip	2000.0	91	1.630	42AH	5.7	2.59	18.5	470	0.7	17	4.0	102	E	
5144.181	Sagebrush	2250.0	91	1.729	44AH	6.8	3.08	18.5	470	0.7	18	4.0	102	E	
5144.181	—	2300.0	61	1.750	44AH	6.8	3.08	18.5	470	0.7	18	4.0	102	E	
5144.181	—	2300.0	91	1.750	44AH	6.8	3.08	18.5	470	0.7	18	4.0	102	E	
5144.188	Lupine	2500.0	91	1.823	44AH	6.6	2.99	18.6	473	0.7	18	4.0	102	E	
5148.197	Bitterroot	2750.0	91	1.912	48AH	8.7	3.95	20.3	514	0.8	21	4.0	102	E	

Terminal Connectors—5800 Series for AAC Conductors, 90°

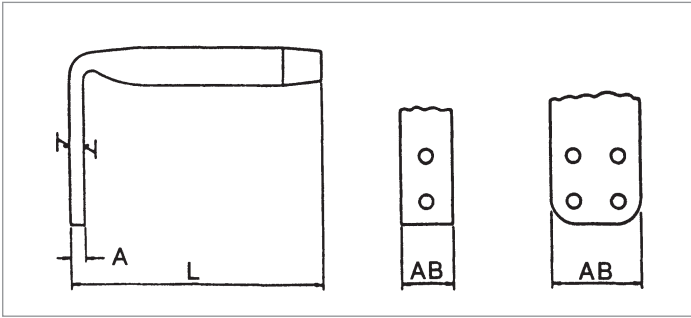

The 5800 Series 90° Terminal Connector is designed for AAC conductors. The terminal connector is fabricated from AFL seamless drawn aluminum.

All terminal connectors are designed for limited tension use, maintaining a minimum of 40% of the ASTM rated strength of the conductor on which it is being used.

Ordering Instructions

Step 1: Assembly Catalog Number

Determine the assembly catalog number based on the conductor being used.

Step 2: Extra High Voltage Finish

For Extra High Voltage Finish, use 'EHV'.
For Standard Finish, leave blank.

Step 3: Assemble Catalog Number.

Assy Catalog Number + **EHV Finish**

Example:

For 795 Arbutus conductor with an EHV finish, the complete catalog number is:

5830.109EHV

TERMINAL CATALOG NUMBER	CODE WORD	CONDUCTOR			DIE SIZE	TOTAL WEIGHT		DIMENSION						PAD SIZE
		SIZE	STRANDING	DIA.	ALUMINUM HEX DIE			L		A		AB		
						KCMIL	AL	IN	LBS	KG	IN	MM	IN	
5873.391	Poppy	1/0	7	0.368	73AH	0.2	0.07	3.9	99	0.2	5	1.0	25	B
5874.438	Aster	2/0	7	0.414	74AH	0.3	0.15	4.9	124	0.3	9	1.0	25	B
5874.484	Phlox	3/0	7	0.464	74AH	0.3	0.13	4.9	124	0.3	8	1.0	25	B
5875.547	Oxlip	4/0	7	0.522	75AH	0.5	0.24	6.0	152	0.5	13	1.0	25	B
5875.609	Valerian	250.0	19	0.575	75AH	0.5	0.22	6.3	159	0.5	12	1.0	25	B
5875.609	Laurel	266.8	19	0.593	75AH	0.5	0.22	6.3	159	0.5	12	1.0	25	B
5876.656	Peony	300.0	19	0.629	76AH	0.8	0.38	7.1	181	0.6	15	1.3	32	B
5876.688	Tulip	336.4	19	0.666	76AH	0.8	0.37	7.3	184	0.6	14	1.3	32	B
5820.719	Daffodil	350.0	19	0.679	76AH	0.8	0.36	7.3	184	0.5	13	1.3	32	B
5876.750	Canna	397.5	19	0.724	76AH	0.7	0.34	7.4	187	0.5	13	1.3	32	B
5820.812	Goldentuft	450.0	19	0.770	20AH	0.9	0.39	8.9	226	0.5	12	1.3	32	B
5820.812	Yarrow	450.0	37	0.772	20AH	0.9	0.39	8.9	226	0.5	12	1.3	32	B
5820.812	Cosmos	477.0	19	0.793	20AH	0.9	0.39	8.9	226	0.5	12	1.3	32	B
5820.812	Syringa	477.0	37	0.795	20AH	0.9	0.39	8.9	226	0.5	12	1.3	32	B
5824.875	Cosmos	477.0	19	0.793	24AH	1.5	0.68	9.4	238	0.6	16	1.5	38	B
5824.875	Syringa	477.0	37	0.795	24AH	1.5	0.68	9.4	238	0.6	16	1.5	38	B

Notes:

1. Pad Dimensions are on page 117.
2. AFL Filler Compound (AFC) Requirements are on page 115.
3. Installation Instructions for Terminals are on page 131.
4. Bolts, nuts and washers are not supplied with the 90° terminal connector.

Terminal Connectors—5800 Series for AAC Conductors, 90° (cont.)

TERMINAL CATALOG NUMBER	CODE WORD	CONDUCTOR			DIE SIZE	TOTAL WEIGHT		DIMENSION						PAD SIZE
		SIZE	STRANDING	DIA.	ALUMINUM HEX DIE	LBS	KG	L		A		AB		
								KCMIL	AL	IN	IN	MM	IN	
5824.875	Zinnia	500.0	19	0.811	24AH	1.5	0.68	9.4	238	0.6	16	1.5	38	B
5824.875	Hyacinth	500.0	37	0.813	24AH	1.5	0.68	9.4	238	0.6	16	1.5	38	B
5824.938	Dahlia	556.5	19	0.856	24AH	1.4	0.64	9.5	241	0.6	15	1.5	38	B
5824.938	Mistletoe	556.5	37	0.858	24AH	1.4	0.64	9.5	241	0.6	15	1.5	38	B
5824.938	Meadowsweet	600.0	37	0.891	24AH	1.4	0.64	9.5	241	0.6	15	1.5	38	B
5824.969	Orchid	636.0	37	0.918	24AH	1.4	0.64	9.5	241	0.6	15	1.5	38	B
5824.969	Heuchera	650.0	37	0.928	24AH	1.4	0.64	9.5	241	0.6	15	1.5	38	B
5827.100	Flag	700.0	61	0.964	27AH	1.7	0.77	8.9	226	0.4	10	3.0	76	D
5827.106	Violet	715.5	37	0.974	27AH	1.7	0.77	8.9	226	0.4	10	3.0	76	D
5827.106	Nasturtium	715.5	61	0.975	27AH	1.7	0.77	8.9	226	0.4	10	3.0	76	D
5827.106	Petunia	750.0	37	0.997	27AH	1.7	0.77	8.9	226	0.4	10	3.0	76	D
5827.106	Cattail	750.0	61	0.998	27AH	1.7	0.77	8.9	226	0.4	10	3.0	76	D
5830.109	Arbutus	795.0	37	1.026	30AH	2.4	1.09	10.3	260	0.5	13	3.0	76	D
5830.109	Lilac	795.0	61	1.028	30AH	2.4	1.09	10.3	260	0.5	13	3.0	76	D
5830.109	—	800.0	37	1.031	30AH	2.4	1.09	10.3	260	0.5	13	3.0	76	D
5830.109	Heliotrope	800.0	61	1.031	30AH	2.4	1.09	10.3	260	0.5	13	3.0	76	D
5830.116	Snapdragon	900.0	61	1.094	30AH	2.3	1.04	10.5	267	0.5	12	3.0	76	D
5830.122	Magnolia	954.0	37	1.124	30AH	2.2	1.00	10.8	273	0.4	10	3.0	76	D
5830.122	Goldenrod	954.0	61	1.126	30AH	2.2	1.00	10.8	273	0.4	10	3.0	76	D
5830.122	Camellia	1000.0	61	1.152	30AH	2.2	1.00	10.8	273	0.4	10	3.0	76	D
5830.122	Bluebell	1033.5	37	1.170	30AH	2.2	1.00	10.8	273	0.4	10	3.0	76	D
5830.122	Larkspur	1033.5	61	1.172	30AH	2.2	1.00	10.8	273	0.4	10	3.0	76	D
5834.128	Marigold	1113.0	61	1.216	34AH	3.3	1.50	11.5	292	0.6	16	3.0	76	D
5834.134	Hawthorn	1192.5	61	1.258	34AH	3.2	1.45	11.5	292	0.6	15	3.0	76	D
5834.134	Narcissus	1272.0	61	1.300	34AH	3.2	1.45	11.5	292	0.6	15	3.0	76	D
5836.144	Columbine	1351.0	61	1.340	36AH	3.5	1.59	12.1	308	0.6	15	3.0	76	D
5836.144	Carnation	1431.0	61	1.379	36AH	3.5	1.59	12.1	308	0.6	15	3.0	76	D
5836.147	—	1500.0	91	1.412	36AH	3.5	1.59	12.1	308	0.6	16	3.0	76	D
5836.147	Gladiolus	1510.5	61	1.416	36AH	3.5	1.59	12.1	308	0.6	16	3.0	76	D
5838.156	Coreopsis	1590.0	61	1.453	38AH	4.2	1.91	13.6	346	0.7	17	3.0	76	D
5838.156	Dogwood	1590.0	91	1.454	38AH	4.2	1.91	13.6	346	0.7	17	3.0	76	D
5840.162	Jessamine	1750.0	61	1.525	40AH	4.7	2.13	13.3	338	0.7	17	3.0	76	D
5842.178	Cowslip	2000.0	91	1.630	42AH	5.5	2.49	14.5	368	0.7	17	4.0	102	E
5844.181	Sagebrush	2250.0	91	1.729	44AH	6.7	3.04	14.6	371	0.7	18	4.0	102	E
5844.181	—	2300.0	61	1.750	44AH	6.7	3.04	14.6	371	0.7	18	4.0	102	E
5844.181	—	2300.0	91	1.750	44AH	6.7	3.04	14.6	371	0.7	18	4.0	102	E
5844.188	Lupine	2500.0	91	1.823	44AH	6.6	2.99	15.1	384	0.7	18	4.0	102	E
5848.197	Bitterroot	2750.0	91	1.912	48AH	8.5	3.86	16.4	416	0.8	21	4.0	102	E

Tee Connector—5500 Series for AAC Conductors, Open Run

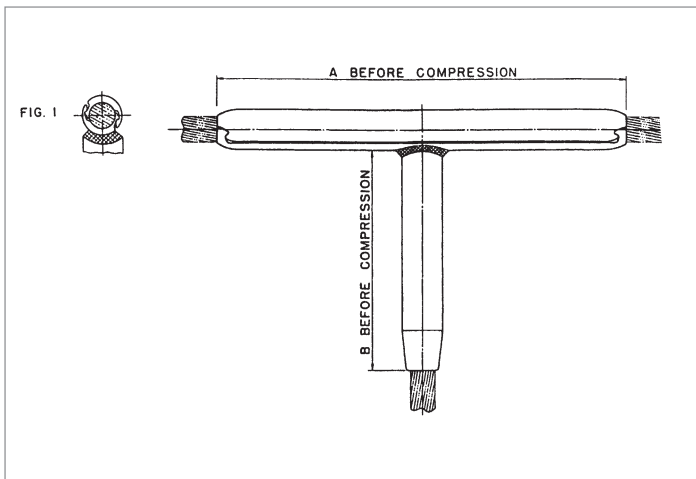

The 5500 Series Tee Connector is a permanent drop designed for AAC conductors. The tee connector is fabricated from AFL seamless drawn aluminum.

The run portion incorporates an improved design of interlocking extrusions, providing a permanent grip on the conductor when compressed.

The branch portion of the tee connector is designed for limited tension use, maintaining a minimum of 40% of the ASTM rated strength of the conductor on which it is being used.

For die size sections 30AH and above, the end tapers of the compression portions of all compression accessories are supplied with a high voltage finish.

Ordering Instructions

Step 1: Determine Run Catalog Number

Determine the run catalog number based on the conductor being used.

Step 2: Determine Branch Catalog Number

Determine the branch catalog number based on the conductor being used.

Step 3: Assemble Catalog Number



Example:

For 795 Arbutus conductor in both the Run and Branch, the complete catalog number is:

5530.3 – 30.109

Notes:

1. AFL Filler Compound (AFC) Requirements are on page 115.
2. Installation Instructions for Open Run Tee Connectors are on page 145.

Tee Connector—5500 Series for AAC Conductors, Open Run (cont.)

CODE WORD	CONDUCTOR			CATALOG NUMBER		DIE SIZE	WEIGHT				DIMENSIONS			
	SIZE	STRANDING	DIA.	RUN CONDUCTOR	BRANCH CONDUCTOR		RUN		BRANCH		A		B	
	KCMIL	AL	IN				LBS	KG	LBS	KG	IN	MM	IN	MM
Aster	2/0	7	0.414	5574	74.438	74AH	0.2	0.10	0.2	0.09	7.6	192	5.5	140
Phlox	3/0	7	0.464	5574	74.484	74AH	0.2	0.10	0.8	0.09	7.6	192	5.5	140
Oxlip	4/0	7	0.522	5575	75.547	75AH	0.4	0.18	0.3	0.14	8.6	217	6.0	152
Laurel	266.8	19	0.593	5575	75.609	75AH	0.4	0.18	0.3	0.14	8.6	217	6.0	152
Tulip	336.4	19	0.666	5576	76.688	76AH	0.7	0.30	0.5	0.23	10.0	254	6.5	165
Canna	397.5	19	0.724	5576	76.750	76AH	0.7	0.30	0.5	0.23	10.0	254	6.5	165
Goldentuft	450.0	19	0.770	5520.3	20.812	20AH	1.0	0.45	0.6	0.27	14.5	368	7.6	164
Yarrow	450.0	37	0.772	5520.3	20.812	20AH	1.0	0.45	0.6	0.27	14.5	368	7.6	164
Cosmos	477.0	19	0.793	5520.3	20.812	20AH	1.0	0.45	0.6	0.27	14.5	368	7.6	164
Syringa	477.0	37	0.795	5520.3	20.812	20AH	1.0	0.45	0.6	0.27	14.5	368	7.6	164
Cosmos	477.0	19	0.793	5524.3	24.875	24AH	1.7	0.77	0.8	0.36	15.5	394	8.3	210
Syringa	477.0	37	0.795	5524.3	24.875	24AH	1.7	0.77	0.8	0.36	15.5	394	8.3	210
Zinnia	500.0	19	0.811	5524.3	24.875	24AH	1.7	0.77	0.8	0.36	15.5	394	8.3	210
Hyacinth	500.0	37	0.813	5524.3	24.875	24AH	1.7	0.77	0.8	0.36	15.5	394	8.3	210
Dahlia	556.5	19	0.856	5524.3	24.938	24AH	1.7	0.77	0.8	0.36	15.5	394	8.3	210
Mistletoe	556.5	37	0.858	5524.3	24.938	24AH	1.7	0.77	0.8	0.36	15.5	394	8.3	210
Meadowsweet	600.0	37	0.891	5524.3	24.938	24AH	1.7	0.77	0.8	0.36	15.5	394	8.3	210
Orchid	636.0	37	0.918	5524.3	24.969	24AH	1.7	0.77	0.8	0.36	15.5	394	8.3	210
Heuchera	650.0	37	0.928	5524.3	24.969	24AH	1.7	0.77	0.8	0.36	15.5	394	8.3	210
Flag	700.0	61	0.964	5527.3	27.100	27AH	2.7	1.22	1.3	0.59	18.3	464	8.8	225
Violet	715.5	37	0.974	5527.3	27.106	27AH	2.7	1.22	1.3	0.59	18.3	464	8.8	225
Nasturtium	715.5	61	0.975	5527.3	27.106	27AH	2.7	1.22	1.3	0.59	18.3	464	8.8	225
Petunia	750.0	37	0.997	5527.3	27.106	27AH	2.7	1.22	1.3	0.59	18.3	464	8.8	225
Cattail	750.0	61	0.998	5527.3	27.106	27AH	2.7	1.22	1.3	0.59	18.3	464	8.8	225
Arbutus	795.0	37	1.026	5530.3	30.109	30AH	3.3	1.50	1.7	0.77	19.1	486	9.4	240
Lilac	795.0	61	1.028	5530.3	30.109	30AH	3.3	1.50	1.7	0.77	19.1	486	9.4	240
—	800.0	37	1.031	5530.3	30.109	30AH	3.3	1.50	1.7	0.77	19.1	486	9.4	240
Heliotrope	800.0	61	1.031	5530.3	30.109	30AH	3.3	1.50	1.7	0.77	19.1	486	9.4	240
Snapdragon	900.0	61	1.094	5530.3	30.116	30AH	3.3	1.50	1.7	0.77	19.1	486	9.4	240
Magnolia	954.0	37	1.124	5530.3	30.122	30AH	3.3	1.50	1.7	0.77	19.1	486	9.4	240
Goldenrod	954.0	61	1.126	5530.3	30.122	30AH	3.3	1.50	1.7	0.77	19.1	486	9.4	240
Camellia	1000.0	61	1.152	5530.3	30.122	30AH	3.3	1.50	1.7	0.77	19.1	486	9.4	240
Bluebell	1033.5	37	1.170	5530.3	30.122	30AH	3.3	1.50	1.7	0.77	19.1	486	9.4	240
Larkspur	1033.5	61	1.172	5530.3	30.122	30AH	3.3	1.50	1.7	0.77	19.1	486	9.4	240
Marigold	1113.0	61	1.216	5534.3	34.128	34AH	4.5	2.04	2.2	1.00	20.1	511	10.1	256
Hawthorn	1192.5	61	1.258	5534.3	34.134	34AH	4.5	2.04	2.2	1.00	20.1	511	10.1	256

Tee Connector—5500 Series for AAC Conductors, Open Run (cont.)

CODE WORD	CONDUCTOR			CATALOG NUMBER		DIE SIZE	WEIGHT				DIMENSIONS			
	SIZE	STRANDING	DIA.	RUN CONDUCTOR	BRANCH CONDUCTOR		RUN		BRANCH		A		B	
	KCMIL	AL	IN				LBS	KG	LBS	KG	IN	MM	IN	MM
Narcissus	1272.0	61	1.300	5534.3	34.134	34AH	4.5	2.04	2.2	1.00	20.1	511	10.1	256
Columbine	1351.0	61	1.340	5536.3	36.144	36AH	5.0	2.27	2.5	1.13	21.0	533	10.6	270
Carnation	1431.0	61	1.379	5536.3	36.144	36AH	5.0	2.27	2.5	1.13	21.0	533	10.6	270
—	1500.0	91	1.412	5536.3	36.147	36AH	5.0	2.27	2.5	1.13	21.0	533	10.6	270
Gladiolus	1510.5	61	1.187	5536.3	36.147	36AH	5.0	2.27	2.5	1.13	21.0	533	10.6	270
Coreopsis	1590.0	61	1.250	5538.3	38.156	38AH	5.9	2.68	3.0	1.36	21.9	556	11.2	284
Dogwood	1590.0	91	1.454	5538.3	38.156	38AH	5.9	2.68	3.0	1.36	21.9	556	11.2	284
Jessamine	1750.0	61	1.525	5540.3	40.162	40AH	6.6	2.99	3.4	1.54	22.8	578	11.8	298
Cowslip	2000.0	91	1.630	5542.3	42.178	42AH	7.7	3.49	3.9	1.77	23.6	600	12.4	314
Sagebrush	2250.0	91	1.729	5544.3	44.181	44AH	6.8	3.08	4.0	1.81	24.5	622	12.0	305
—	2300.0	61	1.750	5544.3	44.181	44AH	6.8	3.08	4.0	1.81	24.5	622	12.0	305
—	2300.0	91	1.750	5544.3	44.181	44AH	6.8	3.08	4.0	1.81	24.5	622	12.0	305
Lupine	2500.0	91	1.823	5544.3	44.188	44AH	6.8	3.08	4.0	1.81	24.5	622	12.0	305
Bitterroot	2750.0	91	1.912	5548.3	48.197	48AH	9.1	4.13	5.2	2.36	24.5	622	14.0	358

Tee Tap—5300 Series for AAC Conductors, Open Run

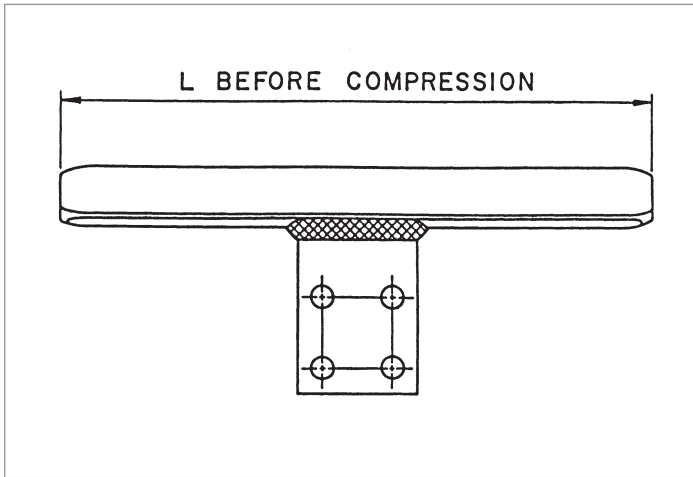

The 5300 Series Tee Tap is a permanent or temporary drop designed for AAC conductors. It is fabricated from AFL seamless drawn aluminum.

The run portion incorporates an improved design of interlocking extrusions, providing a permanent grip on the conductor when compressed.

For die size sections 30AH and above, the end tapers of the compression portions of all compression accessories are supplied with a high voltage finish.

Ordering Instructions

Step 1: Catalog Number

Determine the catalog number based on the conductor being used.

Step 2: Extra High Voltage Finish

For Extra High Voltage Finish, use 'EHV'.

For Standard Finish, leave blank.

Step 3: Assemble Catalog Number.

**Catalog
Number**

+

**EHV
Finish**

Example:

For 795 Arbutus conductor with EHV finish, the complete catalog number is:

5330.3EHV

Notes:

1. Pad Dimensions are on page 117.
2. AFL Filler Compound (AFC) Requirements are on page 115.
3. Bolt sizes and torque recommendations are on page 119.
4. Installation Instructions for Open Run Tee Taps are on page 144.

Tee Tap—5300 Series for AAC Conductors, Open Run (cont.)

TEE TAP CATALOG NUMBER	CONDUCTOR CODE WORD	CONDUCTOR			DIE SIZE ALUMINUM HEX DIE	TOTAL WEIGHT		DIMENSION A		PAD SIZE
		SIZE KCMIL	STRANDING AL	DIA. IN		LBS	KG	IN	MM	
		5374	Aster	2/0	7	0.414	74AH	0.5	0.20	
5374	Phlox	3/0	7	0.464	74AH	0.5	0.20	7.6	192	B
5375	Oxlip	4/0	7	0.522	75AH	0.7	0.34	8.6	217	B
5375	Valerian	250.0	19	0.575	75AH	0.7	0.34	8.6	217	B
5375	Laurel	266.8	19	0.593	75AH	0.7	0.34	8.6	217	B
5376	Peony	300.0	19	0.629	76AH	1.1	0.50	10.0	254	B
5376	Tulip	336.4	19	0.666	76AH	1.1	0.50	10.0	254	B
5376	Daffodil	350.0	19	0.679	76AH	1.1	0.50	10.0	254	B
5376	Canna	397.5	19	0.724	76AH	1.1	0.50	10.0	254	B
5320.3	Goldentuft	450.0	19	0.770	20AH	1.2	0.54	12.5	318	B
5320.3	Yarrow	450.0	37	0.772	20AH	1.2	0.54	12.5	318	B
5320.3	Cosmos	477.0	19	0.793	20AH	1.2	0.54	12.5	318	B
5320.3	Syringa	477.0	37	0.795	20AH	1.2	0.54	12.5	318	B
5324.3	Cosmos	477.0	19	0.793	24AH	1.8	0.82	13.3	337	B
5324.3	Syringa	477.0	37	0.795	24AH	1.8	0.82	13.3	337	B
5324.3	Zinnia	500.0	19	0.811	24AH	1.8	0.82	13.3	337	B
5324.3	Hyacinth	500.0	37	0.813	24AH	1.8	0.82	13.3	337	B
5324.3	Dahlia	556.5	19	0.856	24AH	1.8	0.82	13.3	337	B
5324.3	Mistletoe	556.5	387	0.858	24AH	1.8	0.82	13.3	337	B
5324.3	Meadowsweet	600.0	37	0.891	24AH	1.8	0.82	13.3	337	B
5324.3	Orchid	636.0	37	0.918	24AH	1.8	0.82	13.3	337	B
5324.3	Heuchera	650.0	37	0.928	24AH	1.8	0.82	13.3	337	B
5327.3	Flag	700.0	61	0.964	27AH	3.0	1.36	15.3	387	D
5327.3	Violet	715.5	37	0.974	27AH	3.0	1.36	15.3	387	D
5327.3	Nasturtium	715.5	61	0.975	27AH	3.0	1.36	15.3	387	D
5327.3	Petunia	750.0	37	0.997	27AH	3.0	1.36	15.3	387	D
5327.3	Cattail	750.0	61	0.998	27AH	3.0	1.36	15.3	387	D
5330.3	Arbutus	795.0	37	1.026	30AH	3.4	1.54	16.8	425	D
5330.3	Lilac	795.0	61	1.028	30AH	3.4	1.54	16.8	425	D
5330.3	—	800.0	37	1.031	30AH	3.4	1.54	16.8	425	D
5330.3	Heliotrope	800.0	61	1.031	30AH	3.4	1.54	16.8	425	D
5330.3	Snapdragon	900.0	61	1.094	30AH	3.4	1.54	16.8	425	D
5330.3	Magnolia	954.0	37	1.124	30AH	3.4	1.54	16.8	425	D
5330.3	Goldenrod	954.0	61	1.126	30AH	3.4	1.54	16.8	425	D
5330.3	Camellia	1000.0	61	1.152	30AH	3.4	1.54	16.8	425	D
5330.3	Bluebell	1033.5	37	1.170	30AH	3.4	1.54	16.8	425	D
5330.3	Larkspur	1033.5	61	1.172	30AH	3.4	1.54	16.8	425	D
5334.3	Marigold	1113.0	61	1.216	34AH	4.5	2.04	17.8	451	D
5334.3	Hawthorn	1192.5	61	1.258	34AH	4.5	2.04	17.8	451	D
5334.3	Narcissus	1272.0	61	1.300	34AH	4.5	2.04	17.8	451	D

Tee Tap—5300 Series for AAC Conductors, Open Run (cont.)

TEE TAP CATALOG NUMBER	CODE WORD	CONDUCTOR			DIE SIZE	TOTAL WEIGHT		DIMENSION A		PAD SIZE
		SIZE	STRANDING	DIA.	ALUMINUM HEX DIE	LBS	KG	IN	MM	
		KCMIL	AL	IN						
5336.3	Columbine	1351.0	61	1.340	36AH	4.7	2.13	18.5	470	D
5336.3	Carnation	1431.0	61	1.379	36AH	4.7	2.13	18.5	470	D
5336.3	—	1500.0	91	1.412	36AH	4.7	2.13	18.5	470	D
5336.3	Gladiolus	1510.5	61	1.417	36AH	4.7	2.13	18.5	470	D
5338.3	Coreopsis	1590.0	61	1.454	38AH	5.3	2.40	19.0	483	D
5338.3	Dogwood	1590.0	91	1.454	38AH	5.3	2.40	19.0	483	D
5340.3	Jessamine	1750.0	61	1.525	40AH	6.1	2.77	19.5	495	D
5342.3	Cowslip	2000.0	91	1.630	42AH	7.7	3.49	21.0	533	E
5344.3	Sagebrush	2250.0	91	1.729	44AH	9.7	4.40	22.8	576	E
5344.3	—	2300.0	61	1.750	44AH	9.7	4.40	22.8	576	E
5344.3	—	2300.0	91	1.750	44AH	9.7	4.40	22.8	576	E
5344.3	Lupine	2500.0	91	1.823	44AH	9.7	4.40	22.8	576	E
5348.3	Bitterroot	2750.0	91	1.912	48AH	10.6	4.81	24.0	610	E
5344.3	—	2300.0	91	1.750	44AH	9.7	4.40	22.8	576	E
5344.3	Lupine	2500.0	91	1.823	44AH	9.7	4.40	22.8	576	E
5348.3	Bitterroot	2750.0	91	1.913	48AH	10.6	4.81	24.0	610	E

Compression Dead Ends—33700 Series for AAC and ACAR Conductors, Eye Type, Single Tongue

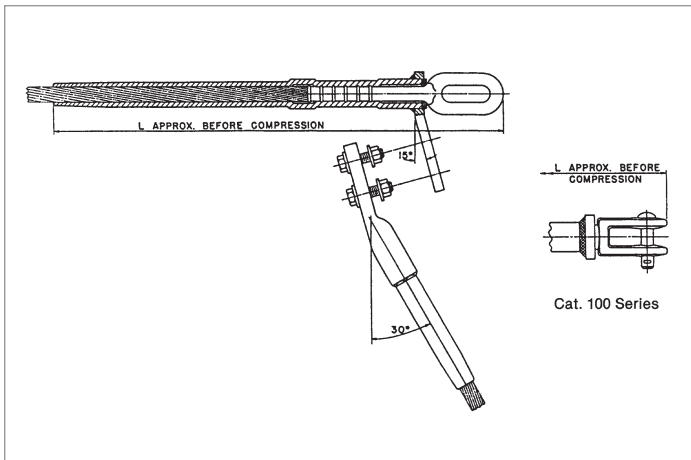

The 33700 Series Dead End Assembly is specifically designed for AAC and ACAR conductors. The aluminum body of the dead end is fabricated from AFL seamless drawn aluminum. The tongue and terminal pad are constructed with a 15° angle, which permits the terminal connector to be bolted in the straight or 30° position.

All dead ends are designed for full tension use, achieving a minimum of 95% of the ASTM rated strength of the conductor on which they are used. Each dead end assembly comes with a dead end body, steel eye, 15° terminal and aluminum hardware.

For die size sections 30AH and above, the end tapers of the compression portions of all compression accessories are supplied with a high voltage finish. Corona bolts are furnished as standard on 15° terminals for these section sizes.

The square edges of bolted pads on compression accessories could cause Corona in environments greater than or equal to 345 kV. Pads with edges and corners rounded can be supplied by adding the catalog suffix "EHV".

Ordering Instructions

Step 1: Assembly Catalog Number

Determine the assembly catalog number based on the conductor being used.

Step 2: Terminal Connector

For an assembly without a terminal connector, use 'NT'.
For an assembly with a terminal connector, leave blank.

Step 3: Extra High Voltage Finish

For Extra High Voltage Finish, use 'EHV'.
For Standard Finish, leave blank.

Step 4: Assemble Catalog Number.



Example:

For 927.2 Greeley conductor with no terminal, the complete catalog number is:

E33714NT

Notes:

1. Eye Dimensions are on page 119.
2. Pad Dimensions are on page 117.
3. AFL Filler Compound (AFC) Requirements are on page 115.
4. Installation Instructions for Dead Ends are on page 133.
5. Installation Instructions for Terminals are on page 131.

Compression Dead Ends—33700 Series for AAC and ACAR Conductors, Eye Type, Single Tongue (cont.)

DEAD END ASSEMBLY CATALOG NUMBER	CONDUCTOR				ALUMINUM BODY SINGLE TONGUE	STEEL COMPONENT		15° TERMINAL CONNECTOR	DIE SIZE		TOTAL WEIGHT		DIMENSION L		PAD SIZE
	CODE WORD	SIZE	STRANDING	DIA.		STEEL EYE	ALUMINUM HEX DIES		LBS	KG	IN	MM			
		KCMIL	AL	IN											
E33703	—	155.4	4/3	0.447	7612.484	9000	5112.484	12AH	2.6	1.16	16.0	406	B		
E33703	Anaheim	155.4	7	0.447	7612.484	9000	5112.484	12AH	2.6	1.16	16.0	406	B		
E33704	—	195.7	4/3	0.502	7613.542	9000	5113.542	13AH	3.0	1.38	16.0	406	B		
E33704	Amherst	195.7	7	0.502	7613.542	9000	5113.542	13AH	3.0	1.38	16.0	406	B		
E33705	—	246.9	4/3	0.563	7613.625	9100	5113.625	13AH	3.0	1.57	17.0	432	B		
E33705	Alliance	246.9	7	0.563	7613.625	9100	5113.625	13AH	3.0	1.57	17.0	432	B		
E33707	Butte	312.8	19	0.642	7614.719	9100	5114.719	14AH	4.0	1.81	17.8	451	B		
E33708	Canton	394.5	19	0.721	7624.781	9200	5124.781	24AH	6.1	2.77	20.3	516	B		
E33709	Cairo	465.4	19	0.783	7624.875C	9200	5124.875	24AH	5.9	2.68	21.6	548	B		
E33709	—	503.6	15/4	0.814	7624.875C	9200	5124.875	24AH	5.9	2.68	21.6	548	B		
E33710	Darlen	559.5	19	0.858	7627.906	9300	5127.906	27AH	8.0	3.63	23.3	591	D		
E33712	—	634.9	12/7	0.914	7627.100	9200	5127.100	27AH	7.2	3.27	23.3	592	D		
E33716	—	649.5	18/19	0.928	7627.100C	9300	5127.100	27AH	7.8	3.54	23.3	592	D		
E33716	—	649.5	24/13	0.928	7627.100C	9300	5127.100	27AH	7.8	3.54	23.3	592	D		
E33716	—	649.5	30/7	0.928	7627.100C	9300	5127.100	27AH	7.8	3.54	23.3	592	D		
E33713	Elgin	652.4	19	0.927	7630.109	9300	5130.109	30AH	9.7	4.40	24.8	629	D		
E33712	—	657.3	15/4	0.930	7627.100	9200	5127.100	27AH	7.2	3.29	23.3	592	D		
E33713	Flint	740.8	37	0.991	7630.109	9300	5130.109	30AH	9.7	4.40	24.8	629	D		
E33717	—	853.7	18/19	1.063	7630.116	9300	5130.116	30AH	8.9	4.04	21.6	548	D		
E33717	—	853.7	24/13	1.063	7630.116	9300	5130.116	30AH	8.9	4.04	21.6	548	D		
E33717	—	853.7	30/7	1.063	7630.116	9300	5130.116	30AH	8.9	4.04	21.6	548	D		
E33714	Greeley	927.2	37	1.108	7634.122	9300	5134.122	34AH	11.9	5.40	25.3	641	D		
E33714	—	927.2	18/19	1.108	7634.122	9300	5134.122	34AH	11.9	5.40	25.3	641	D		
E33714	—	927.2	24/13	1.108	7634.122	9300	5134.122	34AH	11.9	5.40	25.3	641	D		
E33714	—	927.2	30/7	1.108	7634.122	9300	5134.122	34AH	11.9	5.40	25.3	641	D		
E33714	—	1024.5	18/19	1.165	7634.122	9300	5134.122	34AH	11.9	5.40	25.3	641	D		
E33714	—	1024.5	24/13	1.165	7634.122	9300	5134.122	34AH	11.9	5.40	25.3	641	D		
E33714	—	1024.5	30/7	1.165	7634.122	9300	5134.122	34AH	11.9	5.40	25.3	641	D		
E33715	—	1080.6	18/19	1.196	7634.128	9400	5134.128	34AH	12.8	5.81	27.0	686	D		
E33715	—	1080.6	24/13	1.196	7634.128	9400	5134.128	34AH	12.8	5.81	27.0	686	D		
E33715	—	1080.6	30/7	1.196	7634.128	9400	5134.128	34AH	12.8	5.81	27.0	686	D		
E33715	—	1108.6	24/13	1.212	7634.128	9400	5134.128	34AH	12.8	5.81	27.0	686	D		
E33715	—	1172.3	18/19	1.246	7634.128	9400	5134.128	34AH	12.8	5.81	27.0	686	D		
E33715	—	1172.3	24/13	1.246	7634.128	9400	5134.128	34AH	12.8	5.81	27.0	686	D		
E33723	—	1127.0	42/19	1.222	7638.138	E9500	5138.138	38AH	14.6	6.62	23.9	607	D		
E33718	—	1534.0	42/19	1.427	7638.150	E9600	5138.150	38AH	14.2	6.44	24.3	617	D		
E33718	—	1534.0	54/7	1.427	7638.150	E9600	5138.150	38AH	14.2	6.44	24.3	617	D		
E33719	—	1700.0	42/19	1.502	7640.162	E9600	5140.162	40AH	16.5	7.48	24.3	617	E		
E33719	—	1700.0	54/7	1.502	7640.162	E9600	5140.162	40AH	16.5	7.48	24.3	617	E		
E33722	—	1691.0	—	1.498	7644.159	E9700	5144.159	44AH	23.2	10.52	25.6	649	E		
E33720	—	2303.5	54/37	1.750	7648.184	E9800	5148.184	48AH	26.1	11.83	27.3	694	E		
E33720	—	2303.5	63/28	1.750	7648.184	E9800	5148.184	48AH	26.1	11.83	27.3	694	E		
E33720	—	2338.0	42/19	1.762	7648.184	E9800	5148.184	48AH	26.1	11.83	27.3	694	E		

Compression Dead Ends—43100 Series for AAC and ACAR Conductors, Eye Type, Double Tongue

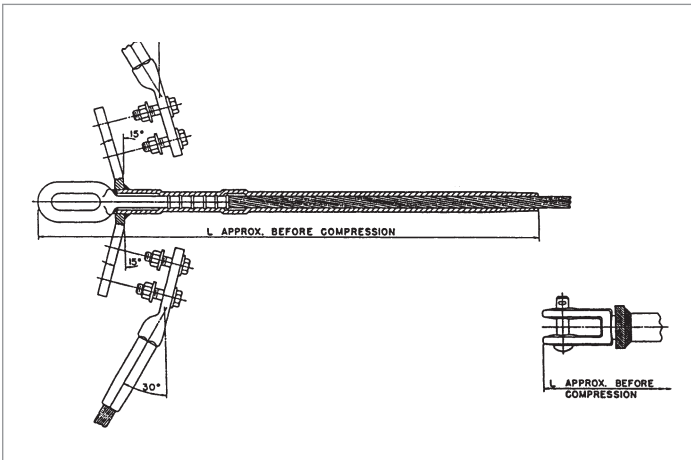

The 43100 Series Double Tongue Dead End Assembly is specifically designed for AAC and ACAR conductors. The aluminum body of the dead end is fabricated from AFL seamless drawn aluminum. The tongue and terminal pad are constructed with a 15° angle, which permits the terminal connector to be bolted in the straight or 30° position.

All dead ends are designed for full tension use, achieving a minimum of 95% of the ASTM rated strength of the conductor on which they are used. Each dead end assembly comes with a dead end body, steel eye, two 15° terminals and aluminum hardware.

For die size sections 30AH and above, the end tapers of the compression portions of all compression accessories are supplied with a high voltage finish. Corona bolts are furnished as standard on 15° terminals for these section sizes.

The square edges of bolted pads on compression accessories could cause Corona in environments greater than or equal to 345 kV. Pads with edges and corners rounded can be supplied by adding the catalog suffix "EHV".

Ordering Instructions

Step 1: Assembly Catalog Number

Determine the assembly catalog number based on the conductor being used.

Step 2: Terminal Connector

For an assembly without a terminal connector, use 'NT'.
For an assembly with a terminal connector, leave blank.

Step 3: Extra High Voltage Finish

For Extra High Voltage Finish, use 'EHV'.
For Standard Finish, leave blank.

Step 4: Assemble Catalog Number.

Assy
Catalog
Number

+

Terminal
Connector

+

EHV
Finish

Example:

For 927.2 Greeley conductor with no terminal, the complete catalog number is:

E43114NT

Notes:

1. Eye Dimensions are on page 119.
2. Pad Dimensions are on page 117.
3. AFL Filler Compound (AFC) Requirements are on page 115.
4. Installation Instructions for Dead Ends are on page 133.
5. Installation Instructions for Terminals are on page 131.

Compression Dead Ends—43100 Series for AAAC and ACAR Conductors, Eye Type, Double Tongue (cont.)

DEAD END ASSEMBLY CATALOG NUMBER	CONDUCTOR				ALUMINUM BODY DOUBLE TONGUE	STEEL EYE	15° TERMINAL CONNECTOR	DIE SIZE	TOTAL WEIGHT		DIMENSION L		PAD SIZE
	CODE WORD	SIZE	STRANDING	DIA.					ALUM. HEX DIES	LBS	KG	IN	
		KCMIL	AL	IN									
E43103	—	155.4	4/3	0.447	7712.484	9000	5112.484	12AH	2.9	1.30	16.0	406	B
E43103	Anaheim	155.4	7	0.447	7712.484	9000	5112.484	12AH	2.9	1.30	16.0	406	B
E43104	—	195.7	4/3	0.502	7713.542	9000	5113.542	13AH	3.3	1.51	16.0	406	B
E43104	Amherst	195.7	7	0.502	7713.542	9000	5113.542	13AH	3.3	1.51	16.0	406	B
E43105	—	246.9	4/3	0.563	7713.625	9100	5113.625	13AH	3.3	1.50	17.0	432	B
E43105	Alliance	246.9	7	0.563	7713.625	9100	5113.625	13AH	3.3	1.50	17.0	432	B
E43107	Butte	312.8	19	0.642	7714.719	9100	5114.719	14AH	4.5	2.04	17.8	451	B
E43108	Canton	394.5	19	0.721	7724.781	9200	5124.781	24AH	6.6	3.00	20.3	516	B
E43109	Cario	465.4	19	0.783	7724.875C	9200	5124.875	24AH	6.4	2.91	21.6	548	B
E43109	—	503.6	15/4	0.814	7724.875C	9200	5124.875	24AH	6.4	2.91	21.6	548	B
E43110	Darien	559.5	19	0.858	7727.906	9300	5127.906	27AH	8.5	3.85	23.3	591	D
E43112	—	634.9	12/7	0.914	7727.100	9200	5127.100	27AH	7.7	3.49	23.3	592	D
E43112	—	657.3	15/4	0.930	7727.100	9200	5127.100	27AH	7.7	3.51	23.3	592	D
E43113	Flint	740.8	37	0.991	7730.109	9300	5130.109	30AH	9.9	4.49	24.8	629	D
E43113	Elgin	652.4	19	0.927	7730.109	9300	5130.109	30AH	9.9	4.49	24.8	629	D
E43114	Greeley	927.2	37	1.108	7734.122	9300	5134.122	34AH	12.0	5.45	25.3	641	D
E43114	—	927.2	18/19	1.108	7734.122	9300	5134.122	34AH	12.0	5.45	25.3	641	D
E43114	—	927.2	24/13	1.108	7734.122	9300	5134.122	34AH	12.0	5.45	25.3	641	D
E43114	—	927.2	30/7	1.108	7734.122	9300	5134.122	34AH	12.0	5.45	25.3	641	D
E43114	—	1024.5	18/19	1.165	7734.122	9300	5134.122	34AH	12.0	5.45	25.3	641	D
E43114	—	1024.5	24/13	1.165	7734.122	9300	5134.122	34AH	12.0	5.45	25.3	641	D
E43114	—	1024.5	30/7	1.165	7734.122	9300	5134.122	34AH	12.0	5.45	25.3	641	D
E43115	—	1080.6	18/19	1.196	7734.128	9400	5134.128	34AH	12.9	5.85	27.0	686	D
E43115	—	1080.6	24/13	1.196	7734.128	9400	5134.128	34AH	12.9	5.85	27.0	686	D
E43115	—	1080.6	30/7	1.196	7734.128	9400	5134.128	34AH	12.9	5.85	27.0	686	D
E43115	—	1108.6	24/13	1.212	7734.128	9400	5134.128	34AH	12.9	5.85	27.0	686	D
E43115	—	1172.3	18/19	1.246	7734.128	9400	5134.128	34AH	12.9	5.85	27.0	686	D
E43115	—	1172.3	24/13	1.246	7734.128	9400	5134.128	34AH	12.9	5.85	27.0	686	D
E43116	—	649.5	18/19	0.928	7727.100C	9300	5127.100	27AH	8.3	3.76	23.3	592	D
E43116	—	649.5	24/13	0.928	7727.100C	9300	5127.100	27AH	8.3	3.76	23.3	592	D
E43116	—	649.5	30/7	0.928	7727.100C	9300	5127.100	27AH	8.3	3.76	23.3	592	D
E43117	—	853.7	24/13	1.063	7730.116	9300	5130.116	30AH	9.1	4.13	21.6	548	D
E43117	—	853.7	30/7	1.063	7730.116	9300	5130.116	30AH	9.1	6.13	21.6	548	D
E43117	—	853.7	18/19	1.063	7730.116	9300	5130.116	30AH	9.1	6.13	21.6	548	D

Compression Dead Ends—43100 Series for AAAC and ACAR Conductors, Eye Type, Double Tongue (cont.)

DEAD END ASSEMBLY CATALOG NUMBER	CONDUCTOR				ALUMINUM BODY DOUBLE TONGUE	STEEL EYE	15° TERMINAL CONNECTOR	DIE SIZE	TOTAL WEIGHT		DIMENSION L		PAD SIZE
	CODE WORD	SIZE	STRANDING	DIA.					ALUM. HEX DIES	LBS	KG	IN	
		KCMIL	AL	IN									
E43118	—	1534.0	42/19	1.427	7738.150	E9600	5138.150	38AH	15.3	6.49	24.3	617	D
E43118	—	1534.0	54/7	1.427	7738.150	E9600	5138.150	38AH	15.3	6.49	24.3	617	D
E43119	—	1700.0	42/19	1.502	7740.162	E9600	5140.162	40AH	18.3	8.30	24.3	617	D
E43119	—	1700.0	54/7	1.502	7741.162	E9600	5140.162	40AH	18.3	8.30	24.3	617	E
E43120	—	2303.5	54/37	1.750	7748.184	E9800	5148.184	48AH	27.1	12.29	27.3	694	E
E43120	—	2303.5	63/28	1.750	7748.184	E9800	5148.184	48AH	27.1	12.29	27.3	694	E
E43120	—	2338.0	42/19	1.762	7748.184	E9800	5148.184	48AH	27.1	12.29	27.3	694	E
E43120	—	2303.5	—	1.750	7748.184	E9800	5148.184	48AH	27.1	12.29	27.3	694	E
E43120	—	2303.5	—	1.750	7748.184	E9800	5148.184	48AH	27.1	12.29	27.3	694	E
E43120	—	2338.0	—	1.762	7748.184	E9800	5148.184	48AH	27.1	12.29	27.3	694	E
E43122	—	1691.0	—	1.498	7744.159	E9700	5144.159	44AH	23.6	10.71	25.6	649	E
E43122	—	1691.0	—	1.498	7744.159	E9700	5144.159	44AH	23.6	10.71	25.6	649	E
E43123	—	1127.0	42/19	1.222	7738.138	E9500	5138.138	38AH	15.5	7.03	23.9	607	D

Compression Dead Ends—43400 Series for AAC and ACAR Conductors, Adjustable Clevis Type, Single Tongue

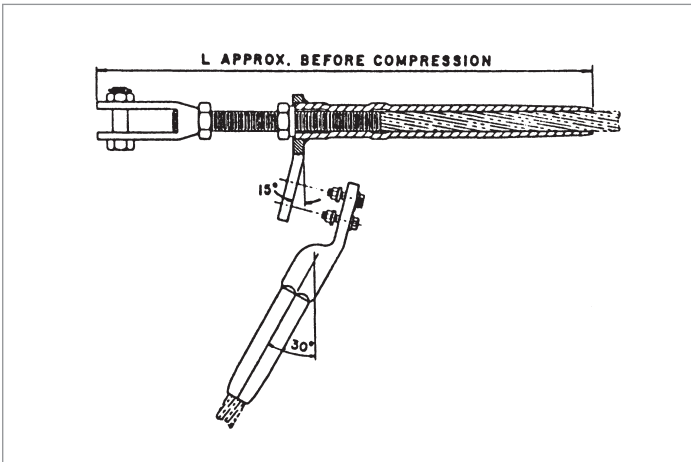

The 43400 Series Adjustable Clevis Dead End Assembly is specifically designed for AAC and ACAR conductors. The aluminum body of the dead end is fabricated from AFL seamless drawn aluminum. The tongue and terminal pad are constructed with a 15° angle, which permits the terminal connector to be bolted in the straight of 30° position.

All dead ends are designed for full tension use, achieving a minimum of 95% of the ASTM rated strength of the conductor on which they are used. Each dead end assembly comes with a dead end body, adjustable steel clevis, 15° terminal and aluminum hardware.

For die size sections 30AH and above, the end tapers of the compression portions of all compression accessories are supplied with a high voltage finish. Corona bolts are furnished as standard on 15° terminals for these section sizes.

The square edges of bolted pads on compression accessories could cause Corona in environments greater than or equal to 345 kV. Pads with edges and corners rounded can be supplied by adding the catalog suffix "EHV".

Ordering Instructions

Step 1: Assembly Catalog Number

Determine the assembly catalog number based on the conductor being used.

Step 2: Terminal Connector

For an assembly without a terminal connector, use 'NT'.
For an assembly with a terminal connector, leave blank.

Step 3: Extra High Voltage Finish

For Extra High Voltage Finish, use 'EHV'.
For Standard Finish, leave blank.

Step 4: Assemble Catalog Number.



Example:

For 394.5 Canton conductor with no terminal, the complete catalog number is:

C43408NT

Notes:

1. Adjustable Clevis Dimensions are on page 120.
2. Pad Dimensions are on page 117.
3. AFL Filler Compound (AFC) Requirements are on page 115.
4. Installation Instructions for Dead Ends are on page 133.
5. Installation Instructions for Terminals are on page 131.

Compression Dead Ends—43400 Series for AAAC and ACAR Conductors, Adjustable Clevis Type, Single Tongue (cont.)

DEAD END ASSEMBLY CATALOG NUMBER	CONDUCTOR				ALUMINUM BODY SINGLE TONGUE	ADJUSTABLE STEEL CLEVIS	15° TERMINAL CONNECTOR	DIE SIZE	TOTAL WEIGHT		DIMENSION L		PAD SIZE
	CODE WORD	SIZE	STRANDING	DIA.					ALUMINUM HEX DIES	LBS	KG	IN	
		KCMIL	AL	IN									
C43408	Canton	394.5	19	0.721	7624.781C	C6100	5124.781	24AH	8.2	3.58	27.1	687	B
C43409	Cairo	465.4	19	0.783	7624.875	C6100	5124.875	24AH	8.0	3.49	28.4	721	B
C43409	—	503.6	15/4	0.814	7624.875	C6100	5124.875	24AH	8.0	3.49	28.4	721	B
C43410	Darien	559.5	19	0.858	7627.906C	C6200	5127.906	27AH	10.6	4.54	30.0	762	D
C43412	—	634.9	12/7	0.914	7627.100	C6200	5127.100	27AH	9.9	4.45	30.2	768	D
C43416	—	649.5	18/19	0.928	7627.100C	C6200	5127.100	27AH	10.5	4.45	30.2	768	D
C43416	—	649.5	24/13	0.928	7627.100C	C6200	5127.100	27AH	10.5	4.45	30.2	768	D
C43416	—	649.5	30/7	0.928	7627.100C	C6200	5127.100	27AH	10.5	4.45	30.2	768	D
C43413	Elgin	652.4	19	0.927	7630.109C	C6300	5130.109	30AH	16.2	6.89	33.2	846	D
C43412	—	657.3	15/4	0.930	7627.100	C6200	5127.100	27AH	11.6	4.45	30.2	768	D
C43417	—	853.7	18/19	1.063	7630.116	C6300	5130.116	30AH	15.4	6.53	30.6	776	D
C43417	—	853.7	24/13	1.063	7630.116	C6300	5130.116	30AH	15.4	6.53	30.6	776	D
C43417	—	853.7	30/7	1.063	7630.116	C6300	5130.116	30AH	15.4	6.53	30.6	776	D
C43414	—	927.2	18/19	1.106	7634.122C	C6400	5134.122	34AH	19.1	8.26	34.6	878	D
C43414	—	927.2	24/13	1.106	7634.122C	C6400	5134.122	34AH	19.1	8.26	34.6	878	D
C43414	—	927.2	30/7	1.106	7634.122C	C6400	5134.122	34AH	19.1	8.26	34.6	878	D
C43414	—	1024.5	18/19	1.165	7634.122C	C6400	5134.122	34AH	18.1	8.26	34.6	878	D
C43414	—	1024.5	24/13	1.165	7634.122C	C6400	5134.122	34AH	18.1	8.26	34.6	878	D
C43414	—	1024.5	30/7	1.165	7634.122C	C6400	5134.122	34AH	18.1	8.26	34.6	878	D
C43415	—	1080.6	18/19	1.196	7634.128	C6400	5134.128	34AH	19.3	8.35	36.2	919	D
C43415	—	1080.6	24/13	1.196	7634.128	C6400	5134.128	34AH	19.3	8.35	36.2	919	D
C43415	—	1080.6	30/7	1.196	7634.128	C6400	5134.128	34AH	19.3	8.35	36.2	919	D
C43415	—	1108.6	24/13	1.212	7634.128	C6400	5134.128	34AH	20.1	8.35	36.2	919	D
C43415	—	1172.3	18/19	1.246	7634.128	C6400	5134.128	34AH	16.9	8.35	36.2	919	D
C43415	—	1172.3	24/13	1.246	7634.128	C6400	5134.128	34AH	16.9	8.35	36.2	919	D
C43418	—	1534.0	42/19	1.427	7638.150	C6500	5138.150	38AH	17.3	9.03	33.4	848	D
C43418	—	1534.0	54/7	1.427	7638.150	C6500	5138.150	38AH	17.3	9.03	33.4	848	D
C43419	—	1700.0	42/19	1.502	7640.162	C6600	5140.162	40AH	22.7	11.84	35.9	913	E
C43419	—	1700.0	54/7	1.502	7640.162	C6600	5140.162	40AH	22.7	11.84	35.9	913	E

Compression Dead Ends—43500 Series for AAC and ACAR Conductors, Adjustable Clevis Type, Double Tongue

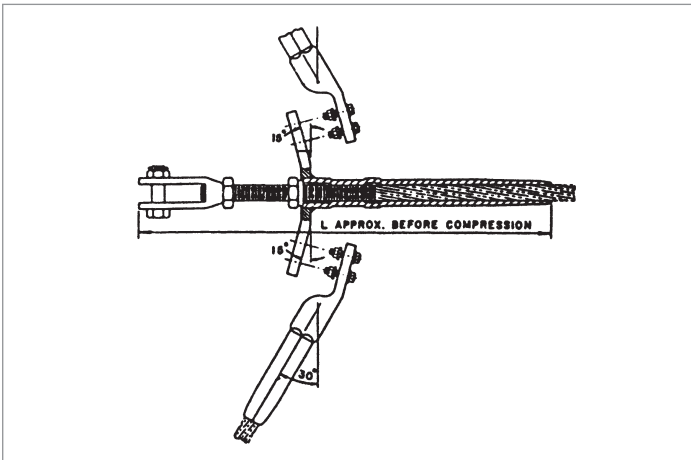

The 43500 Series Adjustable Clevis Dead End assembly is specifically designed for AAC and ACAR conductors. The aluminum body of the dead end is fabricated from AFL seamless drawn aluminum. The tongue and terminal pad are constructed with a 15° angle, which permits the terminal connector to be bolted in the straight of 30° position.

All dead ends are designed for full tension use, achieving a minimum of 95% of the ASTM rated strength of the conductor on which they are used. Each dead end assembly comes with a dead end body, adjustable steel clevis, two 15° terminals and aluminum hardware.

For die size sections 30AH and above, the end tapers of the compression portions of all compression accessories are supplied with a high voltage finish. Corona bolts are furnished as standard on 15° terminals for these section sizes.

The square edges of bolted pads on compression accessories could cause Corona in environments greater than or equal to 345 kV. Pads with edges and corners rounded can be supplied by adding the catalog suffix "EHV".

Ordering Instructions

Step 1: Assembly Catalog Number

Determine the assembly catalog number based on the conductor being used.

Step 2: Terminal Connector

For an assembly without a terminal connector, use 'NT'.
For an assembly with a terminal connector, leave blank.

Step 3: Extra High Voltage Finish

For Extra High Voltage Finish, use 'EHV'.
For Standard Finish, leave blank.

Step 4: Assemble Catalog Number.



Example:

For 652.4 Elgin conductor with no terminal and EHV finish, the complete catalog number is:

C43513NTEHV

Notes:

1. Adjustable Clevis Dimensions are on page 120.
2. Pad Dimensions are on page 117.
3. AFL Filler Compound (AFC) Requirements are on page 115.
4. Installation Instructions for Dead Ends are on page 133.
5. Installation Instructions for Terminals are on page 131.

Compression Dead Ends—43500 Series for AAAC and ACAR Conductors, Adjustable Clevis Type, Double Tongue (cont.)

DEAD END ASSEMBLY CATALOG NUMBER	CONDUCTOR				ALUMINUM BODY DOUBLE TONGUE	ADJUSTABLE STEEL CLEVIS	15° TERMINAL CONNECTOR	DIE SIZE	TOTAL WEIGHT		DIMENSION L		PAD SIZE
	CODE WORD	SIZE	STRANDING	DIA.				ALUMINUM HEX DIES	LBS	KG	IN	MM	
		KCMIL	AL	IN									
C43508	Canton	394.5	19	0.721	7724.781C	C6100	5124.781	24AH	8.7	3.81	27.1	687	B
C43509	Cairo	465.4	19	0.783	7724.875	C6100	5124.875	24AH	8.5	3.72	28.4	721	B
C43509	—	503.6	15/4	0.814	7724.875	C6100	5124.875	24AH	8.5	3.72	28.4	721	B
C43510	Darien	559.5	19	0.858	7727.906C	C6200	5127.906	27AH	11.1	4.76	30.0	762	D
C43512	—	634.9	12/7	0.914	7727.100	C6200	5127.100	27AH	10.3	4.67	30.2	768	D
C43516	—	649.5	18/19	0.928	7727.100C	C6200	5127.100	27AH	11.0	4.67	30.3	768	D
C43516	—	649.5	24/13	0.928	7727.100C	C6200	5127.100	27AH	11.0	4.67	30.3	768	D
C43516	—	649.5	30/7	0.928	7727.100C	C6200	5127.100	27AH	11.0	4.67	30.3	768	D
C43513	Elgin	652.4	19	0.927	7730.109C	C6300	5130.109	30AH	16.4	6.98	33.3	846	D
C43512	—	657.3	15/4	0.930	7727.100	C6200	5127.100	27AH	12.1	4.67	30.3	768	D
C43517	—	853.7	18/19	1.063	7730.116	C6300	5130.116	30AH	15.6	6.62	30.6	776	D
C43517	—	853.7	24/13	1.063	7730.116	C6300	5130.116	30AH	15.6	6.62	30.6	776	D
C43517	—	853.7	30/7	1.063	7730.116	C6300	5130.116	30AH	15.6	6.62	30.6	776	D
C43514	—	927.2	18/19	1.106	7734.122C	C6400	5134.122	34AH	18.2	8.31	34.6	878	D
C43514	—	927.2	24/13	1.106	7734.122C	C6400	5134.122	34AH	18.2	8.31	34.6	878	D
C43514	—	927.2	30/7	1.106	7734.122C	C6400	5134.122	34AH	18.2	8.31	34.6	878	D
C43514	—	1024.5	18/19	1.165	7734.122C	C6400	5134.122	34AH	18.2	8.31	34.6	878	D
C43514	—	1024.5	24/13	1.165	7734.122C	C6400	5134.122	34AH	18.2	8.31	34.6	878	D
C43514	—	1024.5	30/7	1.165	7734.122C	C6400	5134.122	34AH	18.2	8.31	34.6	878	D
C43515	—	1080.6	18/19	1.196	7734.128	C6400	5134.128	34AH	19.4	8.39	36.2	919	D
C43515	—	1080.6	24/13	1.196	7734.128	C6400	5134.128	34AH	19.4	8.39	36.2	919	D
C43515	—	1080.6	30/7	1.196	7734.128	C6400	5134.128	34AH	19.4	8.39	36.2	919	D
C43515	—	1108.6	24/13	1.212	7734.128	C6400	5134.128	34AH	20.2	8.39	36.2	919	D
C43515	—	1172.3	18/19	1.246	7734.128	C6400	5134.128	34AH	20.2	8.39	36.2	919	D
C43515	—	1172.3	24/13	1.246	7734.128	C6400	5134.128	34AH	20.2	8.39	36.2	919	D
C43515	—	1534.0	42/19	1.427	7734.128	C6400	5134.128	34AH	17.0	8.39	36.2	919	D
C43518	—	1534.0	54/7	1.427	7738.150	C6500	5138.150	38AH	17.4	9.08	33.4	848	D
C43518	—	1700.0	42/19	1.502	7738.150	C6500	5138.150	38AH	17.4	9.08	33.4	848	D
C43519	—	1700.0	54/7	1.502	7740.162	C6600	5140.162	40AH	24.5	12.66	35.9	913	E

Compression Joints – Jiffy Joints—7500 Series for AAC and ACAR Conductors

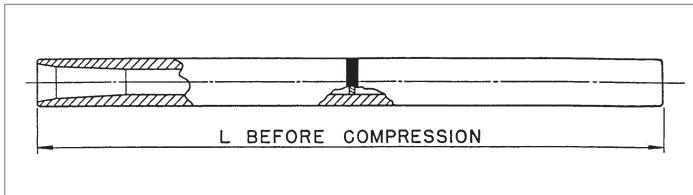

The 7500 Series Compression Joint (Jiffy Joint) is designed for AAC and ACAR conductors. The aluminum body is fabricated from AFL seamless drawn aluminum. The compression joint is a single piece unit without a steel sleeve and comes prefilled with AFL Filler Compound (AFC).

All compression joints are designed for full tension use, achieving a minimum of 95% of the ASTM rated strength of the conductor on which they are used.

For die size sections 30AH and above, the end tapers of the compression portions of all compression accessories are supplied with a high voltage finish.

Ordering Instructions

Step 1: Assembly Catalog Number

Determine the assembly catalog number based on the conductor being used.

Example:

For 312.8 Butte conductor, the complete catalog number is:

7514.719

JOINT CATALOG NUMBER	CONDUCTOR			DIE SIZE ALUMINUM HEX DIES	WEIGHT		COLOR CODE	DIMENSION L	
	CODE NAME	SIZE	DIA.		LBS	KG		IN	MM
		KCMIL	IN						
7506.250	Akron	30.58	0.198	06AH	0.2	0.08	Blue	10.5	267
7506.298	Alton	48.69	0.250	06AH	0.2	0.08	Orange	12.0	305
7509.375	Ames	77.47	0.316	09AH	0.3	0.15	Red	12.0	305
7511.453	Azuza	123.3	0.398	11AH	0.6	0.28	Yellow	14.0	356
7512.484	Anaheim	155.4	0.447	12AH	0.8	0.37	Gray	14.0	356
7513.542	Amherst	195.7	0.502	13AH	1.1	0.50	Black	14.0	356
7513.625	Alliance	246.9	0.563	13AH	1.1	0.50	Pink	16.0	406
7513.688	—	281.4	0.609	13AH	1.0	0.45	Clear	16.0	406
7514.719	Butte	312.8	0.642	14AH	1.6	0.73	Clear	15.6	395
7514.719	—	355.1	0.684	14AH	1.6	0.73	Clear	15.6	395
7524.781	Canton	394.5	0.721	24AH	2.8	1.27	Clear	19.6	497
7524.781	—	419.6	0.743	24AH	2.8	1.27	Clear	19.6	497
7524.875	Cairo	465.4	0.783	24AH	2.8	1.27	Clear	22.1	560
7524.875	—	503.6	0.814	24AH	2.8	1.27	Clear	22.1	560
7527.906	Darien	559.5	0.858	27AH	3.6	1.63	Clear	24.5	622
7527.906	—	561.1	0.862	27AH	3.6	1.63	Clear	24.5	622
7527.938	—	587.2	0.879	27AH	3.6	1.63	Clear	25.0	635
7530.109	Elgin	652.4	0.927	30AH	4.6	2.09	Clear	27.5	699
7530.109	Flint	740.8	0.991	30AH	4.6	2.09	Clear	27.5	699
7534.122	Greeley	927.2	1.108	34AH	6.2	2.81	Clear	28.5	724

Notes:

1. Joint are prefilled at factory.
2. Installation Instructions for Joints are on page 139.

Repair Sleeves—5200 Series for AAAC and ACAR Conductors

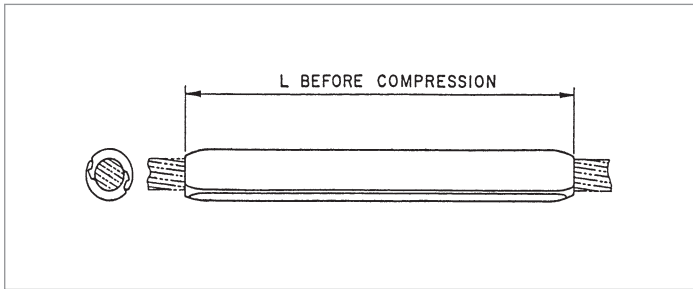

The 5200 Series Repair Sleeve is designed for AAAC and ACAR conductors. The repair sleeve incorporates an improved design of interlocking extrusions, providing a permanent grip on the conductor when compressed.

The repair sleeve will restore 95% of the rated strength of the conductor with up to one-third of the aluminum strands damaged.

Ordering Instructions

Step 1: Assembly Catalog Number

Determine the assembly catalog number based on the conductor being used.

Example:

For 652.4 Elgin conductor, the complete catalog number is:

5224.3

REPAIR SLEEVE AFL NO.	CONDUCTOR				DIE SIZE ALUMINUM HEX DIE	WEIGHT		DIMENSION L	
	CODE NAME	SIZE	STRANDING	DIA.		LBS	KG	IN	MM
		KCMIL	AL	IN					
5274	—	155.4	4/3	0.447	74AH	0.2	0.10	7.6	175
5274	Anaheim	155.4	7	0.447	74AH	0.2	0.10	7.6	175
5275	—	195.7	4/3	0.502	75AH	0.4	0.18	8.6	217
5275	Amherst	195.7	7	0.502	75AH	0.4	0.18	8.6	217
5275	—	246.9	4/3	0.563	75AH	0.4	0.18	8.6	217
5275	Alliance	246.9	7	0.563	75AH	0.4	0.18	8.6	217
5276	Butte	312.8	19	0.642	76AH	0.7	0.30	10.0	254
5220.3	Canton	394.5	19	0.721	20AH	1.0	0.45	14.5	368
5220.3	Cairo	465.4	19	0.783	20AH	1.0	0.45	14.5	368
5220.3	—	503.6	15/4	0.814	20AH	1.0	0.45	14.5	368
5224.3	Darlen	559.5	19	0.858	24AH	1.7	0.77	15.5	394
5224.3	—	634.9	12/7	0.914	24AH	1.7	0.77	15.5	394
5224.3	—	649.5	18/19	0.928	24AH	1.7	0.77	15.5	394
5224.3	—	649.5	24/13	0.928	24AH	1.7	0.77	15.5	394
5224.3	—	649.5	30/7	0.928	24AH	1.7	0.77	15.5	394
5224.3	Elgin	652.4	19	0.927	24AH	1.7	0.77	15.5	394

Notes:

1. AFL Filler Compound (AFC) Requirements are on page 115.
2. Installation Instructions for Repair Sleeves are on page 142.

Repair Sleeves—5200 Series for AAAC and ACAR Conductors (cont.)

REPAIR SLEEVE AFL NO.	CODE NAME	CONDUCTOR			DIE SIZE	WEIGHT		DIMENSION L	
		SIZE	STRANDING	DIA.	ALUMINUM HEX DIE	LBS	KG	IN	MM
		KCMIL	AL	IN					
5224.3	—	657.3	15/4	0.930	24AH	1.7	0.77	15.5	394
5227.3	Flint	740.8	37	0.991	27AH	2.6	1.18	18.3	464
5230.3	—	853.7	18/19	1.063	30AH	3.0	1.36	19.1	486
5230.3	—	853.7	24/13	1.063	30AH	3.0	1.36	19.1	486
5230.3	—	853.7	30/7	1.063	30AH	3.0	1.36	19.1	486
5230.3	Greeley	927.2	37	1.108	30AH	3.0	1.36	19.1	486
5230.3	—	927.2	18/19	1.108	30AH	3.0	1.36	19.1	486
5230.3	—	927.2	24/13	1.108	30AH	3.0	1.36	19.1	486
5230.3	—	927.2	30/7	1.108	30AH	3.0	1.36	19.1	486
5230.3	—	1024.5	18/19	1.165	30AH	3.0	1.36	19.1	486
5230.3	—	1024.5	24/13	1.165	30AH	3.0	1.36	19.1	486
5230.3	—	1024.5	30/7	1.165	30AH	3.0	1.36	19.1	486
5230.3	—	1080.6	18/19	1.196	30AH	3.0	1.36	19.1	486
5230.3	—	1080.6	24/13	1.196	30AH	3.0	1.36	19.1	486
5230.3	—	1080.6	30/7	1.196	30AH	3.0	1.36	19.1	486
5234.3	—	1108.6	24/13	1.212	34AH	4.2	1.91	20.1	511
5234.3	—	1172.3	18/19	1.246	34AH	4.2	1.91	20.1	511
5234.3	—	1172.3	24/13	1.246	34AH	4.2	1.91	20.1	511
5234.3	—	1127.0	42/19	1.222	34AH	4.2	1.91	20.1	511
5238.3	—	1534.0	42/19	1.427	38AH	5.2	2.36	21.9	556
5238.3	—	1534.0	54/7	1.427	38AH	5.2	2.36	21.9	556
5240.3	—	1700.0	42/19	1.502	40AH	6.1	2.77	22.8	578
5240.3	—	1700.0	54/7	1.502	40AH	6.1	2.77	22.8	578
5240.3	—	1691.0		1.498	40AH	6.1	2.77	22.8	578
5244.3	—	2303.5	54/37	1.750	44AH	8.7	3.95	24.5	622
5244.3	—	2303.5	63/28	1.750	44AH	8.7	3.95	24.5	622
5244.3	—	2338.0	42/19	1.762	44AH	8.7	3.95	24.5	622

Terminal Connectors—5100 Series for AAAC and ACAR Conductors, 15°

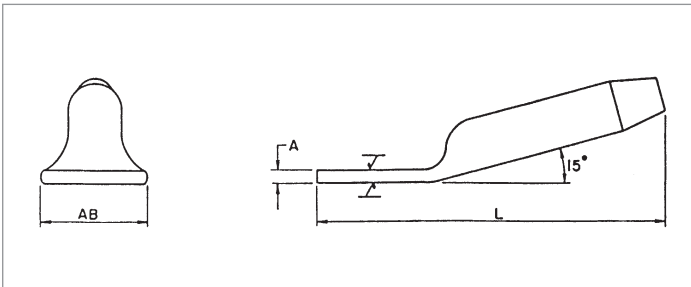

The 5100 Series 15° Terminal Connector is designed for AAAC and ACAR conductors. The terminal connector is fabricated from AFL seamless drawn aluminum.

When used with the dead end, the 15° terminal connector can be bolted in either the straight or 30° position. All terminal connectors are designed for limited tension use, maintaining a minimum of 40% of the ASTM rated strength of the conductor on which it is being used. Aluminum hardware is supplied with the 15° terminal connector.

Ordering Instructions

Step 1: Assembly Catalog Number

Determine the assembly catalog number based on the conductor being used.

Step 2: Extra High Voltage Finish

For Extra High Voltage Finish, use 'EHV'.
For Standard Finish, leave blank.

Step 3: Assemble Catalog Number.

Assy Catalog Number + **EHV Finish**

Example:

For 927.2 Greeley conductor with an EHV finish, the complete catalog number is:

5134.122EHV

TERMINAL CATALOG NUMBER	CONDUCTOR					TOTAL WEIGHT		DIMENSIONS						PAD SIZE
	CODE WORD	SIZE	STRANDING	DIA.	DIE SIZE			L		A		AB		
		KCMIL		IN		IN	MM	IN	MM	IN	MM			
5112.484	—	155.4	4/3	0.447	12AH	0.7	0.32	9.6	244	0.5	13	1.0	25	B
5112.484	Anaheim	155.4	7	0.447	12AH	0.7	0.32	9.6	244	0.5	13	1.0	25	B
5113.542	—	195.7	4/3	0.502	13AH	0.9	0.40	10.8	273	0.5	13	1.3	32	B
5113.542	Amherst	195.7	7	0.502	13AH	0.9	0.40	10.8	273	0.5	13	1.3	32	B
5113.625	—	246.9	4/3	0.563	13AH	0.9	0.39	11.2	284	0.4	11	1.3	32	B
5113.625	Alliance	246.9	7	0.563	13AH	0.9	0.39	11.2	284	0.4	11	1.3	32	B
5114.719	Butte	312.8	19	0.642	14AH	1.0	0.45	10.8	275	0.5	12	1.3	32	B
5124.781	Canton	394.5	19	0.721	24AH	1.8	0.82	12.4	314	0.7	18	1.5	38	B
5124.875	Cairo	465.4	19	0.783	24AH	1.6	0.73	12.6	319	0.6	16	1.5	38	B
5124.875	—	503.6	15/4	0.814	24AH	1.6	0.73	12.6	319	0.6	16	1.5	38	B

Notes:

1. Pad Dimensions are on page 117.
2. AFL Filler Compound (AFC) Requirements are on page 115.
3. Installation Instructions for Terminals are on page 131.
4. Supplied with aluminum hardware.

Terminal Connectors—5100 Series for AAAC and ACAR Conductors, 15° (cont.)

TERMINAL CATALOG NUMBER	CONDUCTOR				DIE SIZE	TOTAL WEIGHT		DIMENSIONS						PAD SIZE
	CODE WORD	SIZE	STRANDING	DIA.		LBS	KG	L		A		AB		
		KCMIL		IN				IN	MM	IN	MM	IN	MM	
5127.906	Darien	559.5	19	0.858	27AH	2.1	0.95	12.3	313	0.4	10	3.0	76	D
5127.100	—	634.9	12/7	0.914	27AH	1.9	0.86	12.3	313	0.4	10	3.0	76	D
5127.100	—	649.5	18/19	0.928	27AH	1.9	0.86	12.3	313	0.4	10	3.0	76	D
5127.100	—	649.5	24/13	0.928	27AH	1.9	0.86	12.3	313	0.4	10	3.0	76	D
5127.100	—	649.5	30/7	0.928	27AH	1.9	0.86	12.3	313	0.4	10	3.0	76	D
5130.109	Elgin	652.4	19	0.927	30AH	2.7	1.23	13.6	346	0.5	13	3.0	76	D
5127.100	—	657.3	15/4	0.930	27AH	1.9	0.86	12.3	313	0.4	10	3.0	76	D
5130.109	Flint	740.8	37	0.991	30AH	2.7	1.23	13.6	346	0.5	13	3.0	76	D
5130.116	—	853.7	18/19	1.063	30AH	2.6	1.18	13.9	354	0.5	12	3.0	76	D
5130.116	—	853.7	24/13	1.063	30AH	2.6	1.18	13.9	354	0.5	12	3.0	76	D
5130.116	—	853.7	30/7	1.063	30AH	2.6	1.18	13.9	354	0.5	12	3.0	76	D
5134.122	Greeley	927.2	37	1.108	34AH	3.7	1.68	14.1	359	0.7	18	3.0	76	D
5134.122	—	927.2	18/19	1.108	34AH	3.7	1.68	14.1	359	0.7	18	3.0	76	D
5134.122	—	927.2	24/13	1.108	34AH	3.7	1.68	14.1	359	0.7	18	3.0	76	D
5134.122	—	927.2	30/7	1.108	34AH	3.7	1.68	14.1	359	0.7	18	3.0	76	D
5134.122	—	1024.5	18/19	1.165	34AH	3.7	1.68	14.1	359	0.7	18	3.0	76	D
5134.122	—	1024.5	24/13	1.165	34AH	3.7	1.68	14.1	359	0.7	18	3.0	76	D
5134.122	—	1024.5	30/7	1.165	34AH	3.7	1.68	14.1	359	0.7	18	3.0	76	D
5134.128	—	1080.6	18/19	1.196	34AH	3.6	1.64	14.3	363	0.6	16	3.0	76	D
5134.128	—	1080.6	24/13	1.196	34AH	3.6	1.64	14.3	363	0.6	16	3.0	76	D
5134.128	—	1080.6	30/7	1.196	34AH	3.6	1.64	14.3	363	0.6	16	3.0	76	D
5138.138	—	1127.0	42/19	1.222	34AH	3.4	1.55	14.6	370	0.6	15	3.0	76	D
5134.128	—	1172.3	18/19	1.246	34AH	3.6	1.64	14.3	363	0.6	16	3.0	76	D
5134.128	—	1172.3	24/13	1.246	34AH	3.6	1.64	14.3	363	0.6	16	3.0	76	D
5134.128	—	1180.6	24/13	1.212	34AH	3.6	1.64	14.3	363	0.6	16	3.0	76	D
5138.150	—	1534.0	42/19	1.427	38AH	4.5	2.05	15.8	400	0.8	20	3.0	76	D
5138.150	—	1534.0	54/7	1.427	38AH	4.5	2.05	15.8	400	0.8	20	3.0	76	D
5144.159	—	1691.0	--	1.498	44AH	7.4	3.36	18.0	457	0.8	20	4.0	102	E
5140.162	—	1700.0	42/19	1.502	40AH	5.3	2.41	17.4	443	0.7	18	4.0	102	E
5140.162	—	1700.0	54/7	1.502	40AH	5.3	2.41	17.4	443	0.7	18	4.0	102	E
5148.184	—	2303.5	54/37	1.750	48AH	9.0	4.09	20.0	508	0.9	22	4.0	102	E
5148.184	—	2303.5	63/28	1.750	48AH	9.0	4.09	20.0	508	0.9	22	4.0	102	E
5148.184	—	2338.0	42/19	1.762	48AH	9.0	4.09	20.0	508	0.9	22	4.0	102	E

Compression Dead Ends—33200 Series for AWAC Conductor, Clevis Type, Single Tongue

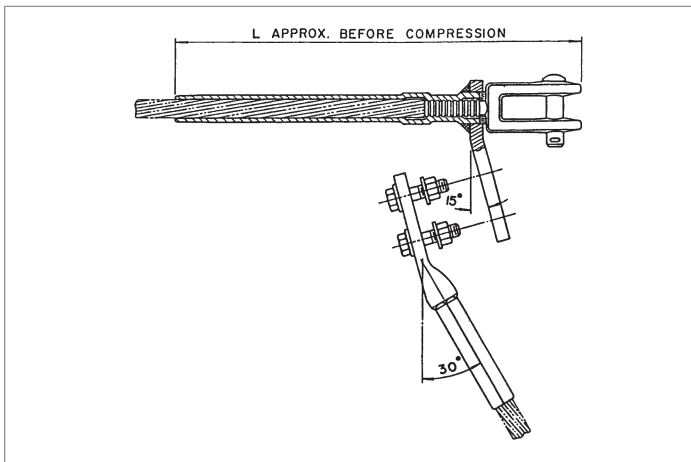

The 33200 Series Dead End Assembly is specifically designed for AWAC conductors. The aluminum body of the dead end is fabricated from AFL seamless drawn aluminum. The tongue and terminal pad are constructed with a 15° angle, which permits the terminal connector to be bolted in the straight or 30° position.

All dead ends are designed for full tension use, achieving a minimum of 95% of the ASTM rated strength of the conductor on which they are used. Each dead end assembly comes with a dead end body, steel clevis, 15° terminal and aluminum hardware.

For die size sections 30AH and above, the end tapers of the compression portions of all compression accessories are supplied with a high voltage finish. Corona bolts are furnished as standard on 15° terminals for these section sizes.

The square edges of bolted pads on compression accessories could cause Corona in environments greater than or equal to 345 kV. Pads with edges and corners rounded can be supplied by adding the catalog suffix "EHV".

Ordering Instructions

Step 1: Assembly Catalog Number

Determine the assembly catalog number based on the conductor being used.

Step 2: Terminal Connector

For an assembly without a terminal connector, use 'NT'.
For an assembly with a terminal connector, leave blank.

Step 3: Extra High Voltage Finish

For Extra High Voltage Finish, use 'EHV'.
For Standard Finish, leave blank.

Step 4: Assemble Catalog Number.



Example:

For 1/0 6/1 conductor with no terminal, the complete catalog number is:

C33210NT

Notes:

1. Clevis Dimensions are on page 120.
2. Pad Dimensions are on page 117.
3. AFL Filler Compound (AFC) Requirements are on page 115.
4. Installation Instructions for Dead Ends are on page 133.
5. Installation Instructions for Terminals are on page 131.

Compression Dead Ends—33200 Series for AWAC Conductor, Clevis Type, Single Tongue (cont.)

DEAD END ASSEMBLY CATALOG NUMBER	CONDUCTOR			ALUMINUM BODY SINGLE TONGUE	STEEL CLEVIS	15° TERMINAL CONNECTOR	DIE SIZE	TOTAL WEIGHT		DIMENSION L		PAD SIZE
	SIZE	STRANDING	DIA.					ALUMINUM HEX DIES	LBS	KG	IN	
	KCMIL	AL/AW	IN				LBS		KG	IN	MM	
C33210	1/0	6/1	0.390	8611.453	A100X	5111.453	11AH	2.09	0.94	14.12	359	B
C33211	1/0	5/2	0.416	8612.516	A100X	5112.516	12AH	2.53	1.15	14.12	359	B
C33212	1/0	4/3	0.447	8613.531	A102X	5113.531	13AH	3.79	1.72	15.38	391	B
C31213	2/0	6/1	0.438	8612.484	A100X	5112.484	12AH	2.55	1.16	14.12	359	B
C33214	2/0	5/2	0.467	8613.542	A102X	5113.542	13AH	3.78	1.72	15.38	391	B
C33215	2/0	4/3	0.502	8676.594	A102X	5176.594	76AH	4.05	1.84	17.38	441	B
C33216	4/0	6/1	0.552	8613.625	A102X	5113.625	13AH	3.66	1.66	15.38	391	B
C33217	4/0	15/4	0.575	8676.656	A102X	5176.656	76AH	3.91	1.78	17.38	441	B
C33218	336.4	18/1	0.679	8676.719	A101X	5176.719	76AH	3.57	1.61	17.38	441	B

Compression Joints—7500 and 8500 Series for AWAC Conductors

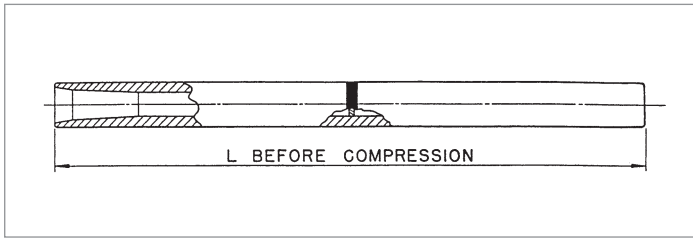

Ordering Instructions

Step 1: Assembly Catalog Number

Determine the assembly catalog number based on the conductor being used.

Example:

For 336.4 18/1 AWAC, the complete catalog number is:

8576.719

The 7500 and 8500 Series Compression Joints are specifically designed for AWAC conductors. The aluminum joint is fabricated from AFL seamless drawn aluminum.

All compression joints are designed for full tension use, achieving a minimum of 95% of the ASTM rated strength of the conductor on which they are used.

For die size sections 30AH and above, the end tapers of the compression portions of all compression accessories are supplied with a high voltage finish.

JOINT CATALOG NUMBER	CONDUCTOR		DIA. IN	DIE SIZE ALUMINUM HEX DIES	WEIGHT		COLOR CODE	DIMENSION L	
	SIZE	STRANDING			LBS	KG		IN	MM
7500 SERIES									
7506.298	4	6/1	0.245	06AH	0.2	0.08	Orange	12.0	305
7509.375	2	6/1	0.309	09AH	0.3	0.15	Red	12.0	305
7511.453	1/0	6/1	0.390	11AH	0.6	0.28	Yellow	14.0	356
7512.484	2/0	6/1	0.438	12AH	0.8	0.37	Gray	14.0	356
7513.625	4/0	6/1	0.552	13AH	1.0	0.45	Pink	16.0	406
8500 SERIES									
8508.312	4	5/2	0.261	08AH	0.2	0.10	Red	9.4	238
8510.344	4	4/3	0.281	10AH	0.5	0.23	Red	12.3	313
8510.438	2	5/2	0.330	10AH	0.4	0.20	Red	12.3	313
8511.438	2	4/3	0.355	11AH	0.6	0.27	Yellow	13.0	330
8512.516	1/0	5/2	0.416	12AH	0.7	0.32	Clear	12.8	324
8513.531	1/0	4/3	0.447	13AH	1.3	0.59	Clear	16.8	425
8513.542	2/0	5/2	0.467	13AH	1.3	0.59	Clear	16.8	425
8576.594	2/0	4/3	0.502	76AH	1.7	0.77	Clear	20.5	521
8576.656	4/0	15/4	0.575	76AH	1.6	0.73	Clear	20.5	521
8576.719	336.4m	18/1	0.679	76AH	1.4	0.64	Clear	20.5	521

Notes:

1. Joints are lined with compound
2. Installation Instructions for Joints are on page 140.

Compression Dead Ends—4500 Series for Alumoweld® and Steel Ground Wire, Eye or Clevis Type, Single Tongue

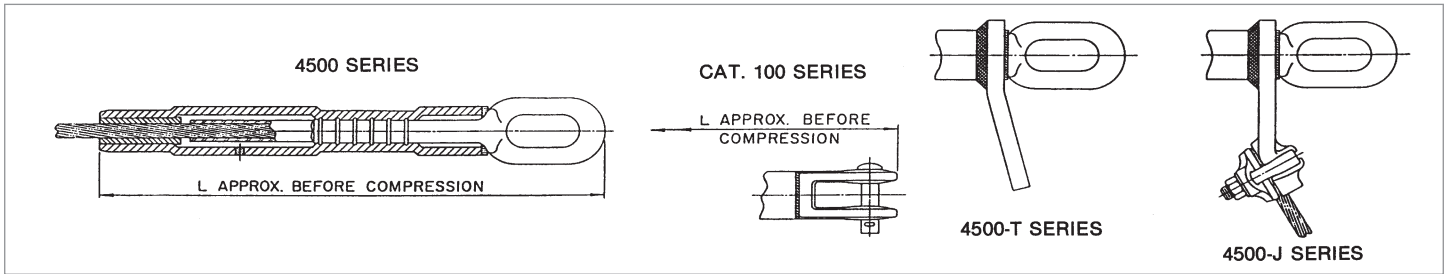

DEAD END ASSEMBLY CATALOG NUMBER	CONDUCTOR			STEEL DEAD END		DIM. L		JUMPER RANGE J SERIES		DIE SIZE		WEIGHT								TERMINAL CONNECTOR CATALOG NUMBER				
	SIZE	STRANDING	DIA. IN	STEEL EYE	STEEL CLEVIS	IN	MM	IN	MM	ALUM. HEX DIES	STEEL HEX DIES	4500 SERIES		4500-T SERIES				4500-J SERIES						
												ALUM.	TOTAL	ALUM.	TOTAL	ALUM.	TOTAL	ALUM.	TOTAL					
ALUMOWELD STRAND																								
E4514.35	3 No. 5	3	0.392	9314.406	—	18.3	465	.312-.625	7.9-15.9	27AH	14SH	1.9	0.86	4.9	2.22	2.3	1.04	5.3	2.4	3.0	1.36	6.0	2.72	5174.438
E4512.36	3 No. 6	3	0.349	9112.377	—	16.9	429	.312-.625	7.9-15.9	20AH	12SH	0.8	0.36	2.5	1.13	1.3	0.59	3.0	1.36	2.0	0.91	3.7	1.68	5109.375
E4510.37	3 No. 7	3	0.311	9110.332	—	16.9	429	.312-.625	7.9-15.9	20AH	10SH	0.9	0.41	2.5	1.13	1.3	0.59	2.9	1.32	2.1	0.95	3.7	1.68	5109.344
E4510.38	3 No. 8	3	0.277	9110.295	—	16.9	429	.312-.625	7.9-15.9	20AH	10SH	0.9	0.41	2.5	1.13	1.3	0.59	3.0	1.36	2.1	0.95	3.8	1.72	5106.312
C4576.39	3 No. 9	3	0.247	—	103.26	11.9	302	.162-.327	4.1-8.3	76AH	76SH	0.5	0.23	2.5	1.13	1.0	0.45	3.0	1.36	0.8	0.36	2.1	0.95	5172.281
C4576.310	3 No. 10	3	0.220	—	103.25	11.9	302	.162-.327	4.1-8.3	76AH	76SH	0.5	0.23	2.5	1.13	1.0	0.45	3.0	1.36	0.8	0.36	2.1	0.95	5172.281
E4518.75	7 No. 5	7	0.546	E9718.578	—	19.2	487	.464-.743	11.8-18.9	34AH	18SH	2.6	1.18	7.9	3.58	4.0	1.81	9.2	4.17	3.5	1.59	8.8	3.99	5175.609
E4516.76	7 No. 6	7	0.486	9416.516	—	18.2	462	.312-.625	7.9-15.9	30AH	16SH	2.2	1.00	6.0	2.72	2.6	1.18	6.4	2.9	3.2	1.45	7.0	3.18	5175.547
E4516.77	7 No. 7	7	0.433	9316.453	—	18.3	465	.312-.625	7.9-15.9	27AH	16SH	1.9	0.86	5.0	2.27	2.3	1.04	5.4	2.45	3.0	1.36	8.1	2.77	5174.484
E4514.78	7 No. 8	7	0.385	9314.406	—	18.3	465	.312-.625	7.9-15.9	27AH	14SH	1.9	0.86	5.0	2.27	2.3	1.04	5.4	2.45	3.0	1.36	6.1	2.77	5174.438
E4512.79	7 No. 9	7	0.343	9112.359	—	16.9	429	.312-.625	7.9-15.9	20AH	12SH	0.8	0.36	2.6	1.18	1.3	0.59	3.1	1.41	2.0	0.91	3.8	1.72	5173.391
E4512.710	7 No. 10	7	0.306	9112.332	—	16.9	429	.312-.625	7.9-15.9	20AH	12SH	0.9	0.41	2.6	1.18	1.3	0.59	3.0	1.36	2.1	0.95	3.8	1.72	5106.344
E4518.191	19 No. 10	19	0.509	E9718.546	—	19.9	505	.464-.743	11.8-18.9	34AH	18SH	2.6	1.18	8.1	3.67	4.0	1.81	9.5	4.31	3.5	1.59	9.0	4.08	5175.547
STEEL GROUND WIRE																								
E 4512.10	5/16 EHS GW	7	0.312	9112.332	—	16.9	429	.312-.625	7.9-15.9	20AH	12SH	0.9	0.41	2.5	1.13	1.3	0.59	3.0	1.36	2.1	0.95	3.8	1.72	5173.357
E4514.12	3/8 EHS GW	7	0.360	9214.377	—	18.1	460	.312-.625	7.9-15.9	27AH	14SH	1.9	0.86	4.0	1.81	2.3	1.04	4.4	2.0	3.0	1.36	5.1	2.31	5173.391
E4516.14	7/16 EHS GW	7	0.435	9316.453	—	18.3	465	.312-.625	7.9-15.9	27AH	16SH	1.9	0.86	5.0	2.27	2.3	1.04	5.4	2.45	3.0	1.36	6.1	2.77	5175.547
E4518.16	1/2 EHS GW	7	0.495	E9718.516	—	19.9	505	.464-.743	11.8-18.9	34AH	18SH	2.6	1.18	7.9	3.58	4.0	1.81	9.3	4.22	3.5	1.59	8.8	3.99	5175.547

Ordering Instructions

Select the catalog number based on the conductor being used. Terminals are to ordered separately.

Options

To order a Dead End with a single tongue, put a "T" at the end of the catalog number. **EXAMPLE: E4516.77T**

To order a Dead End with a bolted jumper, put a "J" at the end of the catalog number. **EXAMPLE: E4516.77J**

Notes:

1. Eye and Clevis Dimensions are on page 119.
2. Pad Dimensions are on page 117.
3. AFL Filler Compound (AFC) Requirements are on page 115.
4. Installation Instructions for Dead Ends are on page 134.
5. Installation Instructions for Terminals are on page 131.
6. The 4500-T Series Dead Ends are supplied with a "B" pad size.

Compression Joints—4900 Series for Alumoweld® and Steel Ground Wire

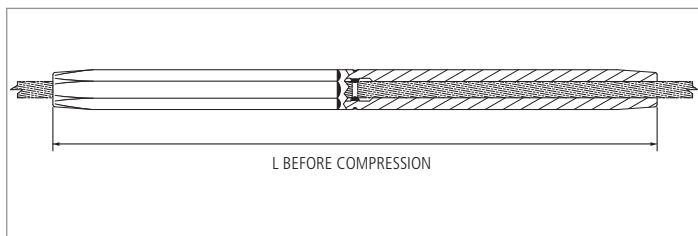

The 4900 Series Compression Joint is specifically designed for Alumoweld and steel ground wires. The aluminum joint is fabricated from AFL seamless drawn aluminum. The 4900 series compression joint consists of only an aluminum sleeve and has no steel sleeve.

The 4900 Series compression joints are designed for full tension use, achieving a minimum of 95% of the ASTM rated breaking strength of the conductor on which they are used.

Ordering Instructions

Step 1: Assembly Catalog Number

Determine the assembly catalog number based on the conductor being used.

Example:

For 7 No. 7 Alumoweld, the complete catalog number is:

4916.484

Alumoweld Strand:

JOINT CATALOG NUMBER	CONDUCTOR			DIE SIZE	WEIGHT		DIMENSION L	
	SIZE	DIAMETER			STEEL HEX DIES	LBS	KG	IN
		IN	MM					
4910.251	3 No. 10	.220	5.6	10SH	0.1	0.05	7.3	184
4910.281	3 No. 9	.247	6.3	10SH	0.1	0.05	7.3	184
4910.295	3 No. 8	.277	7.0	10SH	0.2	0.09	7.5	191
4910.324	3 No. 7	.311	7.9	10SH	0.2	0.09	8.5	216
4912.351	3 No. 6	.349	8.9	12SH	0.3	0.14	9.0	229
4914.406	3 No. 5	.392	10.0	14SH	0.5	0.23	11.0	279
4912.330	7 No. 10	.306	7.8	12SH	0.49	0.22	9.0	356
4912.359	7 No. 9	.343	8.7	12SH	0.3	0.14	9.0	229
4914.406	7 No. 8	.385	9.8	14SH	0.5	0.23	11.0	279
4916.484	7 No. 7	.433	11.0	16SH	0.6	0.27	11.0	279
4916.531	7 No. 6	.486	12.3	16SH	0.6	0.27	11.0	381
4918.594	7 No. 5	.546	13.9	18SH	0.8	0.36	11.0	381
4918.530	19 No. 10	.509	12.9	18SH	1.3	0.59	11.0	431
4920.625	19 No. 9	.572	14.5	20SH	1.1	0.5	12.0	305

Notes:

1. Joints are lined with a compound made up of 60% silicon carbide and 40% CF-1.
2. Installation Instructions for Joints are on page 140.

Compression Joints—4900 Series for Alumoweld® and Steel Ground Wire (cont.)

Steel Ground Wire:

JOINT CATALOG NUMBER	CONDUCTOR				DIE SIZE	WEIGHT		DIMENSION L	
	SIZE	STRANDING	DIAMETER		STEEL HEX DIE	LBS	KG	IN	MM
		STEEL	IN	MM					
4912.332	5/16 EHS G.W.	7	0.312	7.9	12SH	0.5	0.22	14.0	356
4914.386	3/8 EHS G.W.	7	0.360	9.1	14SH	0.6	0.28	13.0	330
4916.453	7/16 EHS G.W.	7	0.435	11.0	16SH	0.9	0.42	15.0	381
4918.531	1/2 EHS G.W.	7	0.495	12.6	18SH	1.3	0.59	17.0	431

Jumper Connectors—5000 Series for Alumoweld® and Steel Ground Wire

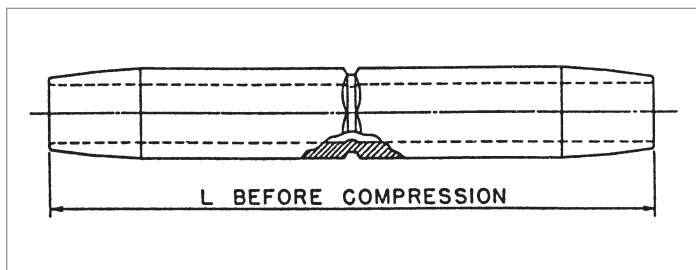

Ordering Instructions

Step 1: Assembly Catalog Number

Determine the assembly catalog number based on the conductor being used.

Example:

For 7 No. 7 Alumoweld, the complete catalog number is:

5074.484

The 5000 Series Jumper Connector is designed for Alumoweld® and steel ground wire. The jumper connector is fabricated from AFL seamless drawn aluminum. All jumper connectors are designed for limited tension use, maintaining a minimum of 40% of the ASTM rated strength of the conductor on which it is being used.

JUMPER CONNECTOR CATALOG NUMBER	CONDUCTOR		DIE SIZE	TOTAL WEIGHT		DIMENSION L	
	SIZE	DIA. IN	ALUMINUM HEX DIE	LBS	KG	IN	MM
ALUMOWELD							
5072.281	3 No. 10	0.220	72AH	0.8	0.04	4.5	114
5072.281	3 No. 9	0.247	72AH	0.8	0.04	4.5	114
5072.312	3 No. 8	0.277	72AH	0.7	0.03	4.5	114
5009.344	3 No. 7	0.311	09AH	0.1	0.05	4.4	111
5009.375	3 No. 6	0.349	09AH	0.1	0.05	4.4	111
5074.438	3 No. 5	0.392	74AH	0.3	0.11	7.0	178
5009.344	7 No. 10	0.306	09AH	0.1	0.05	4.4	111
5073.391	7 No. 9	0.343	73AH	0.1	0.05	6.0	152
5074.438	7 No. 8	0.385	74AH	0.3	0.11	7.0	178
5074.484	7 No. 7	0.433	74AH	0.2	0.10	7.0	178
5075.547	7 No. 6	0.486	75AH	0.4	0.20	8.0	203
5075.609	7 No. 5	0.546	75AH	0.4	0.18	8.0	203
5076.656	19 No. 9	0.572	76AH	0.7	0.31	9.0	229
STEEL GROUND WIRE							
5073.357	5/16-7 Str.	0.312	73AH	0.1	0.05	6.0	152
5074.438	3/8-7 Str.	0.360	74AH	0.3	0.11	7.0	178
5075.547	7/16-7 Str.	0.435	75AH	0.4	0.20	8.0	203
5075.547	1/2-7 Str.	0.495	75AH	0.4	0.20	8.0	203

Notes:

1. AFL Filler Compound (AFC) Requirements are on page 115.
2. Installation Instructions for Jumper Connectors are on page 143.

Terminal Connectors—5600 Series for Alumoweld® and Steel Ground Wire, Straight

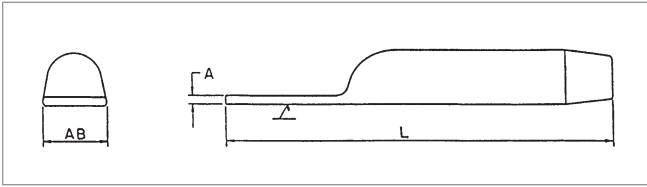

The 5600 Series Straight Terminal Connector is designed for Alumoweld and steel ground wire. The terminal connector is fabricated from AFL seamless drawn aluminum.

When used with the dead end, the straight terminal connector allows drop at a 15° angle. All terminal connectors are designed for limited tension use, maintaining a minimum of 40% of the ASTM rated strength of the conductor on which it is being used.

Ordering Instructions

Step 1: Assembly Catalog Number

Determine the assembly catalog number based on the conductor being used.

Example:

For 7 No. 7 Alumoweld, the complete catalog number is:

5674.484

TERMINAL CONNECTOR CATALOG NUMBER	CONDUCTOR		DIE SIZE	TOTAL WEIGHT		DIMENSION						PAD SIZE
	SIZE	DIA.	ALUMINUM HEX DIE	LBS	KG	L		A		AB		
		IN				IN	MM	IN	MM	IN	MM	
ALUMOWELD												
5672.281	3 No 10	0.220	72AH	0.1	0.06	7.4	189	0.2	5	1.0	25	B
5672.281	3 No 9	0.247	72AH	0.1	0.06	7.4	189	0.2	5	1.0	25	B
5606.312	3 No 8	0.277	06AH	0.3	0.13	7.2	183	0.1	3	1.0	25	B
5609.344	3 No 7	0.311	09AH	0.2	0.09	7.8	197	0.3	7	1.0	25	B
5609.375	3 No 6	0.349	09AH	0.2	0.09	7.8	198	0.3	6	1.0	25	B
5674.438	3 No 5	0.392	74AH	0.3	0.14	8.3	211	0.3	9	1.0	25	B
5606.344	7 No 10	0.306	06AH	0.2	0.09	7.3	185	0.1	3	1.0	25	B
5673.391	7 No 9	0.343	73AH	0.1	0.06	7.6	194	0.2	5	1.0	25	B
5674.438	7 No 8	0.385	74AH	0.3	0.14	8.3	211	0.3	9	1.0	25	B
5674.484	7 No 7	0.433	74AH	0.3	0.12	8.3	211	0.3	8	1.0	25	B
5675.547	7 No 6	0.486	75AH	0.5	0.23	9.5	241	0.5	13	1.0	25	B
5675.609	7 No 5	0.546	75AH	0.5	0.20	9.8	248	0.5	12	1.0	25	B
5676.656	19 No 9	0.572	76AH	0.8	0.38	10.4	265	0.6	15	1.3	32	B
STEEL GROUND WIRE												
5673.357	5/16	0.312	73AH	0.1	0.06	7.4	189	0.2	5	1.0	25	B
5673.391	3/8	0.360	73AH	0.1	0.06	7.6	194	0.2	5	1.0	25	B
5675.547	7/16	0.435	75AH	0.5	0.23	9.5	241	0.5	13	1.0	25	B
5675.547	1/2	0.495	75AH	0.5	0.23	9.5	241	0.5	13	1.0	25	B

Notes:

1. Pad Dimensions are on page 117.
2. AFL Filler Compound (AFC) Requirements are on page 115.
3. Installation Instructions for Terminals are on page 131.
4. Bolts, nuts and washers are not supplied with the straight terminal connector.

Terminal Connectors—5100 Series for Alumoweld® and Steel Ground Wire, 15°

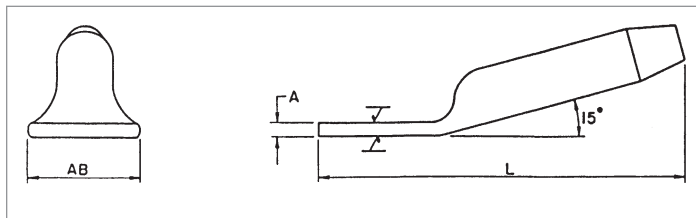

Ordering Instructions

Step 1: Assembly Catalog Number

Determine the assembly catalog number based on the conductor being used.

Example:

For 7 No. 7 Alumoweld, the complete catalog number is:

5174.484

The 5100 Series Straight Terminal Connector is designed for Alumoweld and steel ground wire. The terminal connector is fabricated from AFL seamless drawn aluminum.

When used with the dead end, the 15° terminal connector can be bolted in either the straight or 30° position. All terminal connectors are designed for limited tension use, maintaining a minimum of 40% of the ASTM rated strength of the conductor on which it is being used. Aluminum hardware is supplied with the 15° terminal connector.

TERMINAL CONNECTOR CATALOG NUMBER	CONDUCTOR		DIE SIZE	TOTAL WEIGHT		DIMENSION						PAD SIZE
	SIZE	DIA. IN	ALUMINUM HEX DIE			L		A		AB		
				LBS	KG	IN	MM	IN	MM	IN	MM	
ALUMOWELD												
5172.281	3 No 10	0.220	72AH	0.3	0.12	7.4	189	0.2	5	1.0	25	B
5172.281	3 No 9	0.247	72AH	0.3	0.12	7.4	189	0.2	5	1.0	25	B
5106.312	3 No 8	0.277	06AH	0.3	0.15	7.2	183	0.1	3	1.0	25	B
5109.344	3 No 7	0.311	09AH	0.3	0.15	7.8	197	0.3	7	1.0	25	B
5109.375	3 No 6	0.349	09AH	0.3	0.15	7.8	198	0.3	6	1.0	25	B
5174.438	3 No 5	0.392	74AH	0.4	0.20	8.3	211	0.3	9	1.0	25	B
5106.344	7 No 10	0.306	06AH	0.3	0.15	7.3	185	0.1	3	1.0	25	B
5173.391	7 No 9	0.343	73AH	0.3	0.12	7.6	194	0.2	5	1.0	25	B
5174.438	7 No 8	0.385	74AH	0.4	0.20	8.3	211	0.3	9	1.0	25	B
5174.484	7 No 7	0.433	74AH	0.4	0.19	8.3	211	0.3	8	1.0	25	B
5175.547	7 No 6	0.486	75AH	0.7	0.29	9.5	241	0.5	13	1.0	25	B
5175.609	7 No 5	0.546	75AH	0.6	0.27	9.8	248	0.5	12	1.0	25	B
5176.656	19 No 9	0.572	76AH	0.9	0.42	10.4	265	0.6	15	1.3	32	B
STEEL GROUND WIRE												
5173.357	5/16	0.312	73AH	0.3	0.13	7.4	189	0.2	5	1.0	25	B
5173.391	3/8	0.360	73AH	0.3	0.12	7.6	194	0.2	5	1.0	25	B
5175.547	7/16	0.435	75AH	0.7	0.29	9.5	241	0.5	13	1.0	25	B
5175.547	1/2	0.495	75AH	0.7	0.29	9.5	241	0.5	13	1.0	25	B

Notes:

1. Pad Dimensions are on page 117.
2. AFL Filler Compound (AFC) Requirements are on page 115.
3. Installation Instructions for Terminals are on page 131.
4. Supplied with aluminum hardware.

Terminal Connectors—5800 Series for Alumoweld® and Steel Ground Wire, 90°

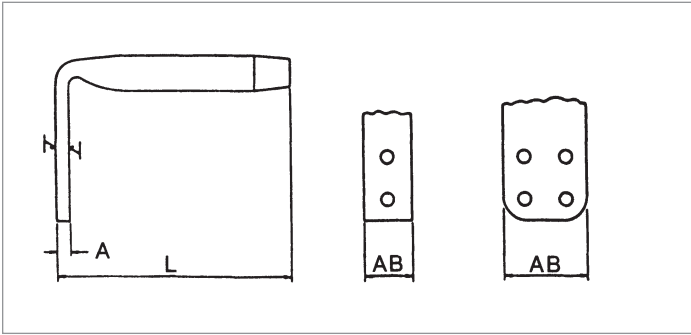

The 5800 Series Terminal Connector is designed for Alumoweld and steel ground wire. The terminal connector is fabricated from AFL seamless drawn aluminum.

All terminal connectors are designed for limited tension use, developing a minimum of 40% of the ASTM rated breaking strength of the cable being used.

Ordering Instructions

Step 1: Assembly Catalog Number

Determine the assembly catalog number based on the conductor being used.

Example:

For 7 No. 7 Alumoweld, the complete catalog number is:

5874.484

TERMINAL CONNECTOR CATALOG NUMBER	CONDUCTOR		DIE SIZE ALUMINUM HEX DIE	TOTAL WEIGHT		DIMENSION						PAD SIZE
	SIZE	DIA. IN		LBS	KG	L		A		AB		
			IN			MM	IN	MM	IN	MM		
ALUMOWELD												
5872.281	3 No 10	0.220	72AH	0.14	0.06	3.8	95	0.19	5	1.0	25	B
5872.281	3 No 9	0.247	72AH	0.14	0.06	3.8	95	0.19	5	1.0	25	B
5806.312	3 No 8	0.277	06AH	0.20	0.09	3.4	86	0.12	3	1.0	25	B
5809.344	3 No 7	0.311	09AH	0.22	0.10	4.4	111	0.28	7	1.0	25	B
5809.375	3 No 6	0.349	09AH	0.21	0.10	4.4	111	0.25	6	1.0	25	B
5873.438	3 No 5	0.392	74AH	0.32	0.15	4.9	124	0.34	9	1.0	25	B
5874.438	3 No 5		74AH	0.32	0.15	4.9	124	0.34	9	1.0	25	B
5806.344	7 No 10	0.306	06AH	0.19	0.09	3.5	89	0.12	3	1.0	25	B
5873.391	7 No 9	0.343	73AH	0.14	0.06	4.0	101	0.19	5	1.0	25	B
5873.438	7 No 8	0.385	74AH	0.32	0.15	4.9	124	0.34	9	1.0	25	B
5874.438	7 No 8		74AH	0.32	0.15	4.9	124	0.34	9	1.0	25	B
5874.484	7 No 7	0.433	74AH	0.29	0.13	4.9	124	0.31	8	1.0	25	B
5875.547	7 No 6	0.486	75AH	0.54	0.24	6.0	152	0.50	13	1.0	25	B
5875.609	7 No 5	0.546	75AH	0.49	0.22	6.3	159	0.47	12	1.0	25	B
5875.547	19 No 10		75AH	0.54	0.24	6.0	152	0.50	13	1.0	25	B
5876.656	19 No 9	0.572	76AH	0.83	0.38	7.1	181	0.59	15	1.3	32	B
STEEL GROUND WIRE												
5873.357	5/16	0.312	73AH	0.15	0.07	3.9	99	0.19	5	1.0	25	B
5873.391	3/8	0.360	73AH	0.14	0.06	4.0	101	0.19	5	1.0	25	B
5875.547	7/16	0.435	75AH	0.54	0.24	6.0	152	0.50	13	1.0	25	B
5875.547	1/2	0.495	75AH	0.54	0.24	6.0	152	0.50	13	1.0	25	B

Notes:

1. Pad Dimensions are on page 117.
2. AFL Filler Compound (AFC) Requirements are on page 115.
3. Installation Instructions for Terminals are on page 131.
4. Bolts, nuts and washers are not supplied with the 90° terminal connector.

AFL Filler Compound (AFC) Required for Compression Accessories

CATALOG SERIES	4500		4600		5000 18000		5100 5600 5800		5200 5300 5500*		5400* 5700		7000 19300		7100 7200		7600 7700	
	LBS	G	LBS	G	LBS	G	LBS	G	LBS	G	LBS	G	LBS	G	LBS	G	LBS	G
71	—	—	—	—	.01	5	—	—	—	—	—	—	.01	5	—	—	—	—
72	—	—	—	—	.01	5	.01	5	—	—	—	—	.01	5	—	—	—	—
73	—	—	—	—	.02	9	.01	5	—	—	—	—	.02	9	—	—	—	—
74	—	—	—	—	.03	14	.02	9	.03	14	—	—	.03	14	.02	9	—	—
75	—	—	—	—	.04	18	.02	9	.05	23	—	—	.05	23	.03	14	—	—
76	.10	45	.10	45	.05	23	.02	9	.07	32	—	—	.07	37	.04	18	—	—
06	—	—	—	—	—	—	.02	9	—	—	—	—	—	—	—	—	—	—
09	—	—	—	—	.03	14	.02	9	—	—	—	—	—	—	—	—	—	—
10	.20	91	—	—	—	—	—	—	—	—	—	—	—	—	—	—	—	—
11	—	—	—	—	—	—	.03	14	—	—	—	—	—	—	—	—	—	—
12	.20	91	—	—	—	—	.03	14	—	—	—	—	—	—	—	—	.01	5
13	—	—	—	—	—	—	.03	14	—	—	—	—	—	—	—	—	.03	14
14	.30	136	—	—	—	—	—	—	—	—	—	—	—	—	—	—	.03	14
16	.50	227	—	—	—	—	—	—	—	—	—	—	—	—	—	—	—	—
18	.45	204	—	—	—	—	—	—	—	—	—	—	—	—	—	—	—	—
20	.30	136	.20	91	.07	32	.03	14	.08	36	.20	91	.08	36	.05	23	—	—
24	—	—	—	—	.09	41	.05	23	.13	59	.30	136	.13	59	.06	27	.04	18
27	—	—	.30	136	.12	54	.06	27	.19	86	.34	154	.17	86	.10	45	.08	36
30	—	—	.50	227	.19	86	.09	41	.32	145	.60	272	.32	145	.15	68	.11	50
34	—	—	.35	159	.25	113	.12	54	.41	186	.93	422	.41	186	.20	91	.32	145
36	—	—	—	—	.28	127	.15	68	.52	236	.96	435	.52	236	.26	118	—	—
38	—	—	—	—	.35	159	.17	77	.58	263	1.1	499	.58	263	.27	122	.27	122
40	—	—	—	—	.40	181	.20	91	.70	318	1.1	499	.70	318	.37	168	.37	168
42	—	—	—	—	.54	245	.24	109	.84	381	1.4	635	.84	381	.45	204	—	—
44	—	—	—	—	.67	304	.28	127	1.2	544	1.5	680	1.2	544	.55	249	—	—
48	—	—	—	—	.78	354	.32	145	1.6	590	1.6	726	1.3	590	.69	313	.62	281

AFL Filler Compound (AFC) Required for Compression Accessories (cont.)

CATALOG SERIES	8000		8100 8200		8300		8400		8600	
	LBS	G	LBS	G	LBS	G	LBS	G	LBS	G
71	—	—	—	—	—	—	—	—	—	—
72	.01	5	—	—	—	—	—	—	—	—
73	.02	9	—	—	—	—	—	—	—	—
74	.03	14	.02	9	—	—	—	—	—	—
75	.05	23	.04	18	—	—	—	—	—	—
76	.09	41	.07	32	—	—	—	—	.09	41
06	—	—	—	—	—	—	—	—	—	—
09	—	—	—	—	—	—	—	—	—	—
10	—	—	—	—	—	—	—	—	—	—
11	—	—	—	—	—	—	—	—	.03	14
12	—	—	—	—	—	—	—	—	.05	23
13	—	—	—	—	—	—	—	—	.06	27
14	—	—	—	—	—	—	—	—	—	—
16	—	—	—	—	—	—	—	—	—	—
18	—	—	—	—	—	—	—	—	—	—
20	.20	91	.14	64	.19	86	.27	122	—	—
24	.30	136	.22	100	.20	91	.26	118	—	—
27	.34	154	.34	154	—	—	—	—	—	—
30	.60	272	.47	213	.40	181	.57	259	—	—
34	.93	422	.56	254	—	—	—	—	—	—
36	.96	435	.62	281	—	—	—	—	—	—
38	1.1	499	.80	363	—	—	—	—	—	—
40	1.1	499	.90	408	—	—	—	—	—	—
42	1.4	635	1.1	499	—	—	—	—	—	—
44	1.5	680	1.2	544	—	—	—	—	—	—
48	1.6	726	.90	408	—	—	—	—	—	—

Notes:

The amount of AFC shown in the tabulation is for the purpose of estimating the amount of compound necessary for a construction project. The tabulated weights of filler compound shown in the above tables for the Catalog 5100, 5600, and 5800 terminals does not include sufficient quantity to fill the cavity area at the transition of the barrel and flat pad. If the terminal is installed with the barrel in the upright position, it is imperative that an additional quantity of AFC be used to fill the cavity area.

NEMA Standard Pad Sizes for Standard Compression Accessories

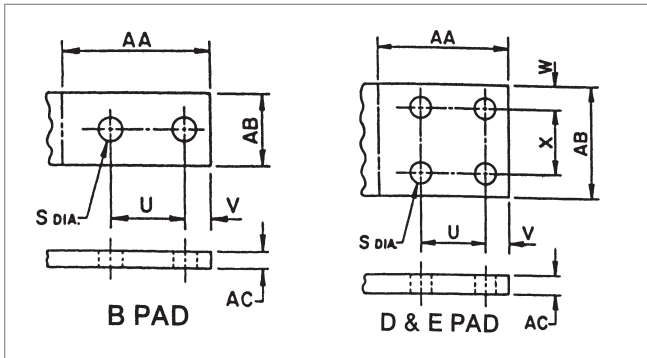

PAD LETTER	DIMENSIONS													
	S		U		V		W		X		AA		AB	
	IN	MM	IN	MM	IN	MM	IN	MM	IN	MM	IN	MM	IN	MM
B	0.56	14	1.75	44	0.62	16	--	--	--	--	3.50	89	1.75	44
D	0.56	14	1.75	44	0.62	16	0.62	16	1.75	44	3.50	89	3.00	76
E	0.56	14	1.75	44	1.12	29	1.12	29	1.75	44	4.50	114	4.00	102

CATALOG SERIES	4500 & 4600				5300				5700				7100, 7200, 8100, 8200,			
	AB		AC		AB		AC		AB		AC		AB		AC	
	IN	MM	IN	MM	IN	MM	IN	MM	IN	MM	IN	MM	IN	MM	IN	MM
74	—	—	—	—	1.75	44	△	△	—	—	—	—	1.75	44	0.50	13
75	—	—	—	—	1.75	44	0.44	11	—	—	—	—	2.25	57	0.50	13
76	2.25	57	0.38	10	1.75	44	0.50	13	—	—	—	—	2.25	57	0.50	13
11	—	—	—	—	—	—	—	—	—	—	—	—	—	—	—	—
12	—	—	—	—	—	—	—	—	—	—	—	—	—	—	—	—
13	—	—	—	—	—	—	—	—	—	—	—	—	—	—	—	—
14	—	—	—	—	—	—	—	—	—	—	—	—	—	—	—	—
20	2.25	57	0.38	10	1.75	44	0.50	13	1.75	44	0.50	13	2.25	57	0.50	13
24	—	—	—	—	1.75	44	0.50	13	1.75	44	0.50	13	2.25	57	0.50	13
27	2.25	57	0.38	10	3.00	76	0.62	16	3.00	76	0.62	16	3.00	76	0.62	16
30	2.38	60	0.38	10	3.00	76	0.62	16	3.00	76	0.62	16	3.00	76	0.62	16
34	3.50	89	0.62	16	3.00	76	0.62	16	3.00	76	0.62	16	3.00	76	0.62	16
36	—	—	—	—	3.00	76	0.62	16	3.00	76	0.62	16	3.00	76	0.62	16
38	—	—	—	—	3.00	76	0.62	16	3.00	76	0.62	16	3.00	76	0.62	16
40	—	—	—	—	3.00	76	0.62	16	3.00	76	0.62	16	4.00	102	0.75	19
42	—	—	—	—	4.00	102	0.75	19	4.00	102	0.75	19	4.00	102	0.75	19
44	—	—	—	—	4.00	102	0.75	19	4.00	102	0.75	19	4.00	102	0.75	19
48	—	—	—	—	4.00	102	0.75	19	4.00	102	0.75	19	4.00	102	0.75	19
74	—	—	—	—	—	—	—	—	—	—	—	—	—	—	—	—
75	—	—	—	—	—	—	—	—	—	—	—	—	—	—	—	—

△ 5374.0 - AC: .44 in (11 mm)
 5374.1 - AC: .50 in (13 mm)
 5374.2 - AC: .50 in (13 mm)

Notes:

1. If catalog number has "EHV" suffix, the pad will be furnished with rounded corners.
2. 15° terminal connectors and dead end tongues are finished on both sides.

NEMA Standard Pad Sizes for Standard Compression Accessories (cont.)

CATALOG SERIES	4500 & 4600				5300				5700				7100, 7200, 8100, 8200,			
	AB		AC		AB		AC		AB		AC		AB		AC	
	IN	MM	IN	MM	IN	MM	IN	MM	IN	MM	IN	MM	IN	MM	IN	MM
76	—	—	—	—	—	—	—	—	—	—	—	—	2.25	57	0.38	10
11	—	—	—	—	—	—	—	—	—	—	—	—	1.75	44	0.38	10
12	2.25	57	0.38	10	2.25	57	0.38	10	—	—	—	—	2.25	57	0.38	10
13	2.25	57	0.38	10	2.25	57	0.38	10	—	—	—	—	2.25	57	0.38	10
14	2.25	57	0.50	13	2.25	57	0.50	13	—	—	—	—	—	—	—	—
20	—	—	—	—	—	—	—	—	2.25	57	0.50	13	—	—	—	—
24	2.25	57	0.50	13	2.25	57	0.50	13	2.25	57	0.50	13	—	—	—	—
27	3.00	76	0.50	13	3.00	76	0.50	13	—	—	—	—	—	—	—	—
30	3.00	76	0.62	16	3.00	76	0.50	13	2.62	67	0.62	16	—	—	—	—
34	3.00	76	0.62	16	3.00	76	0.50	13	—	—	—	—	—	—	—	—
36	—	—	—	—	—	—	—	—	—	—	—	—	—	—	—	—
38	3.00	76	0.62	16	3.00	76	*	*	—	—	—	—	—	—	—	—
40	4.00	102	0.75	19	4.00	102	0.75	19	—	—	—	—	—	—	—	—
42	—	—	—	—	—	—	—	—	—	—	—	—	—	—	—	—
44	4.00	102	0.75	19	4.00	102	0.75	19	—	—	—	—	—	—	—	—
48	4.00	102	0.75	19	4.00	102	0.75	19	—	—	—	—	—	—	—	—

* 7738.138 - AC: .62 in (16 mm)
7738.150 - AC: .50 in (13 mm)

Recommended Tightening Torque for Bolts

Recommended tightening torque for aluminum bolts with Alumilite 205 finish and lubricant coating

BOLT DIAMETER	TORQUE	
	LBF-FT	N.M
5/16	10	14
3/8	15	20
7/16	20	27
1/2	25	34
5/8	40	54
3/4	60	81

Recommended tightening torque for galvanized steel bolts with lubricant coating

BOLT DIAMETER	TORQUE	
	LBF-FT	N.M
5/16	15	20
3/8	25	34
1/2	40	54
5/8	60	81
3/4	75	102

Steel Dead End Dimensions for Standard Compression Accessories

9000 Series Eyes

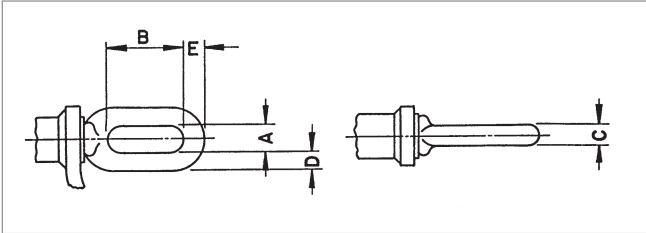

EYE CATALOG SERIES NUMBER	DIMENSIONS									
	A		B		C		D		E	
	IN	MM	IN	MM	IN	MM	IN	MM	IN	MM
9000	0.88	22	2.50	64	0.47	12	0.47	12	0.59	15
9100	0.88	22	2.50	64	0.62	16	0.62	16	0.69	18
9200	0.88	22	2.50	64	0.69	18	0.62	16	0.81	21
9300	1.25	32	2.69	68	0.75	19	0.69	18	0.88	22
9400	1.25	32	2.69	68	0.75	19	0.69	18	0.94	24
E9500	1.25	32	2.62	67	0.78	20	0.78	20	0.91	23
E9600	1.25	32	2.62	67	0.88	22	0.88	22	1.00	25
E9700	1.25	32	2.62	67	1.00	25	1.00	25	1.12	28
E9800	1.31	33	2.62	67	1.00	25	0.97	25	1.25	32

100 Series - Clevis

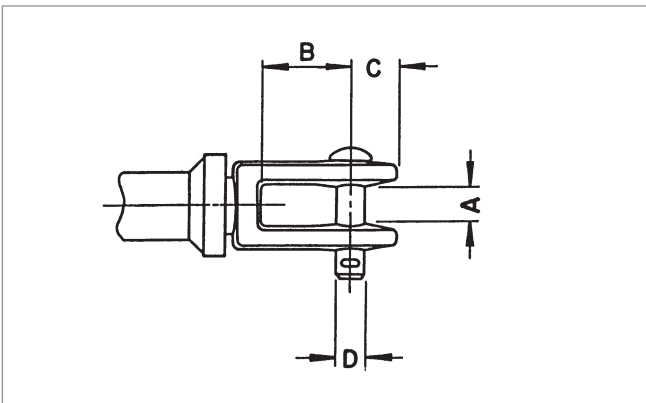

CLEVIS CATALOG SERIES NUMBER	DIMENSIONS							
	A		B		C		D	
	IN	MM	IN	MM	IN	MM	IN	MM
A100X	0.72	18	1.62	41	0.75	19	0.62	16
A101X	0.84	21	2.06	52	1.00	25	0.62	16
A102X	0.84	21	2.06	52	1.00	25	0.62	16
A103X	0.84	21	2.06	52	1.00	25	0.62	16

Steel Dead End Dimensions for Standard Compression Accessories

C6000 Series - Adjustable Clevis

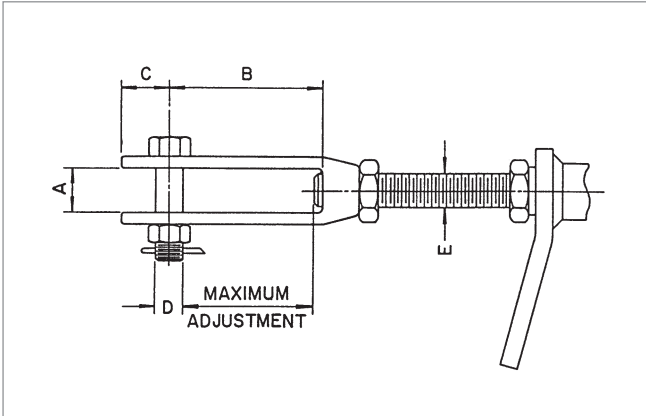

CLEVIS CATALOG SERIES NUMBER	DIMENSIONS										MAXIMUM ADJUSTMENT	
	A		B		C		D		E			
	IN	MM	IN	MM	IN	MM	IN	MM	UNC	IN	MM	
C6100	0.88	22	4.00	102	1.25	32	0.62	16	3/4-10 UNC	3.38	86	
C6200	1.00	25	4.00	102	1.25	32	0.75	19	7/8-9 UNC	3.38	86	
C6300	1.38	35	5.00	127	1.50	38	1.00	25	1-8 UNC	4.25	108	
C6400	1.38	35	5.00	127	1.50	38	1.00	25	1 1/8-7 UNC	4.25	108	
C6500	1.38	35	5.00	127	1.50	38	1.00	25	1 1/4-7 UNC	4.25	108	
C6600	1.62	41	6.00	152	1.75	44	1.12	28	1 3/8-6 UNC	5.12	130	
C6700	1.62	41	6.00	152	1.75	44	1.12	28	1 1/2-6 UNC	5.12	130	
C6800	2.00	51	6.00	152	2.00	51	1.12	28	1 5/8-8 UNC	5.12	130	

Conductor Information for ACSR Conductors

CODE NAME	SIZE	STRANDING	DIAMETER (INCHES)				WEIGHT PER 1000 FT	RATED STRENGTH	RESISTANCE OHMS PER 1000 FT		ALLOWABLE AMPACITY ¹	SAG10® CHART NO.
			INDIVIDUAL WIRES		STEEL CORE	COMPLETE CABLE			DC @ 20°C	AC @ 75°C		
	KCMIL	AL/ST	AL	ST			LBS	LBS			AMPS	
Turkey	6	6/1	0.066	0.066	0.066	0.198	36	1,190	0.641	0.806	105	1-1023
Swan	4	6/1	0.083	0.083	0.083	0.250	57	1,860	0.403	0.515	140	1-1023
Swanate	4	7/1	0.077	0.103	0.103	0.257	67	2,360	0.399	0.519	140	1-670
Sparrow	2	6/1	0.105	0.105	0.105	0.316	91	2,850	0.254	0.332	184	1-1023
Sparate	2	7/1	0.097	0.130	0.130	0.325	107	3,460	0.251	0.338	184	1-670
Robin	1	6/1	0.118	0.118	0.118	0.354	115	3,550	0.201	0.268	212	1-938
Raven	1/0	6/1	0.133	0.133	0.133	0.398	145	4,380	0.159	0.217	242	1-938
Quail	2/0	6/1	0.149	0.149	0.149	0.447	183	5,310	0.126	0.176	276	1-938
Pigeon	3/0	6/1	0.167	0.167	0.167	0.502	231	6,620	0.100	0.144	315	1-938
Penguin	4/0	6/1	0.188	0.188	0.188	0.563	291	8,350	0.080	0.119	357	1-938
Waxwing	266.8	18/1	0.122	0.122	0.122	0.609	289	6,880	0.064	0.079	449	1-844
Partridge	266.8	26/7	0.101	0.079	0.236	0.642	367	11,300	0.064	0.078	475	1-782
Ostrich	300	26/7	0.107	0.084	0.251	0.680	412	12,700	0.057	0.069	492	1-782
Merlin	336.4	18/1	0.137	0.137	0.137	0.684	365	8,680	0.051	0.063	519	1-844
Linnet	336.4	26/7	0.114	0.089	0.265	0.720	462	14,100	0.051	0.062	529	1-782
Oriole	336.4	30/7	0.106	0.106	0.318	0.741	526	17,300	0.050	0.061	535	1-773
Chickadee	397.5	18/1	0.149	0.149	0.149	0.743	431	9,940	0.043	0.053	576	1-844
Brant	397.5	24/7	0.129	0.086	0.257	0.772	511	14,600	0.043	0.053	584	1-889
Ibis	397.5	26/7	0.124	0.096	0.289	0.783	546	16,300	0.043	0.052	587	1-782
Lark	397.5	30/7	0.115	0.115	0.345	0.806	622	20,300	0.043	0.052	594	1-773
Pelican	477	18/1	0.163	0.163	0.163	0.814	517	11,800	0.036	0.044	646	1-844
Flicker	477	24/7	0.141	0.094	0.282	0.846	614	17,200	0.036	0.044	655	1-889
Hawk	477	26/7	0.135	0.105	0.316	0.858	656	19,500	0.036	0.044	659	1-782
Hen	477	30/7	0.126	0.126	0.378	0.883	746	23,800	0.035	0.043	666	1-773
Osprey	556.5	18/1	0.176	0.176	0.176	0.879	603	13,700	0.031	0.038	711	1-844
Parakeet	556.5	24/7	0.152	0.102	0.305	0.914	716	19,800	0.031	0.038	721	1-889
Dove	556.5	26/7	0.146	0.114	0.341	0.927	765	22,600	0.031	0.038	726	1-782
Eagle	556.5	30/7	0.136	0.136	0.409	0.953	871	27,800	0.030	0.037	734	1-773
Peacock	605	24/7	0.159	0.106	0.318	0.953	779	21,600	0.028	0.035	760	1-889
Squab	605	26/7	0.153	0.119	0.356	0.966	832	24,300	0.028	0.035	765	1-782
Wood Duck	605	30/7	0.142	0.142	0.426	0.994	946	28,900	0.028	0.034	774	—
Teal	605	30/19	0.142	0.085	0.426	0.994	939	30,000	0.028	0.034	773	1-757
Kingbird	636	18/1	0.188	0.188	0.188	0.940	690	15,700	0.027	0.033	773	1-844
Swift	636	36/1	0.133	0.133	0.133	0.930	643	13,690	0.027	0.033	769	1-898
Rook	636	24/7	0.163	0.109	0.326	0.977	818	22,000	0.027	0.033	784	1-889
Grosbeak	636	26/7	0.156	0.122	0.365	0.991	874	25,200	0.027	0.033	789	1-782

continued
→

Conductor Information for ACSR Conductors (cont.)

CODE NAME	SIZE	STRANDING	DIAMETER (INCHES)				WEIGHT PER 1000 FT	RATED STRENGTH	RESISTANCE OHMS PER 1000 FT		ALLOWABLE AMPACITY ¹	SAG10® CHART NO.
			INDIVIDUAL WIRES		STEEL CORE	COMPLETE CABLE			DC @ 20°C	AC @ 75°C		
	KCMIL	AL/ST	AL	ST			LBS	LBS			AMPS	
Scoter	636	30/7	0.146	0.146	0.437	1.019	995	30,400	0.026	0.033	798	—
Egret	636	30/19	0.146	0.087	0.437	1.019	987	31,500	0.027	0.033	798	1-757
Flamingo	666.6	24/7	0.167	0.111	0.333	1.000	858	23,700	0.026	0.032	807	1-889
Gannet	666.6	26/7	0.160	0.125	0.374	1.014	916	26,400	0.026	0.031	812	1-782
Stilt	715.5	24/7	0.173	0.115	0.345	1.036	920	25,500	0.024	0.029	844	1-889
Starling	715.5	26/7	0.166	0.129	0.387	1.051	984	28,400	0.024	0.029	849	1-537
Redwing	715.5	30/19	0.154	0.093	0.463	1.081	1,110	34,600	0.024	0.029	859	1-757
Coot	795	36/1	0.149	0.149	0.149	1.040	804	16,710	0.022	0.027	884	1-898
Drake	795	26/7	0.175	0.136	0.408	1.107	1,093	31,500	0.021	0.026	907	1-537
Tern	795	45/7	0.133	0.089	0.266	1.063	895	22,100	0.022	0.027	887	1-955
Condor	795	54/7	0.121	0.121	0.364	1.092	1,023	28,200	0.022	0.027	889	1-838
Mallard	795	30/19	0.163	0.098	0.488	1.140	1,233	38,400	0.021	0.026	918	1-757
Ruddy	900	45/7	0.141	0.094	0.283	1.131	1,013	24,400	0.019	0.024	958	1-955
Canary	900	54/7	0.129	0.129	0.387	1.162	1,158	31,900	0.019	0.024	961	1-838
Rail	954	45/7	0.146	0.097	0.291	1.165	1,074	25,900	0.018	0.023	993	1-955
Cardinal	954	54/7	0.133	0.133	0.399	1.196	1,227	33,800	0.018	0.023	996	1-838
Ortolan	1033.5	45/7	0.152	0.101	0.303	1.212	1,163	27,700	0.017	0.021	1043	1-957
Curlew	1033.5	54/7	0.138	0.138	0.415	1.245	1,330	36,600	0.017	0.021	1047	1-838
Bluejay	1113	45/7	0.157	0.105	0.315	1.258	1,253	29,800	0.016	0.019	1092	1-957
Finch	1113	54/19	0.144	0.086	0.431	1.292	1,429	39,100	0.015	0.020	1093	1-1009
Bunting	1192.5	45/7	0.163	0.109	0.326	1.302	1,342	32,000	0.014	0.018	1139	1-957
Grackle	1192.5	54/19	0.149	0.089	0.446	1.337	1,531	41,900	0.014	0.018	1140	1-1009
Bittern	1272	45/7	0.168	0.112	0.336	1.345	1,432	34,100	0.014	0.017	1184	1-957
Pheasant	1272	54/19	0.154	0.092	0.461	1.381	1,633	34,600	0.014	0.017	1187	1-1009
Dipper	1351.5	45/7	0.173	0.116	0.347	1.386	1,521	36,200	0.013	0.016	1229	1-957
Martin	1351.5	54/19	0.158	0.095	0.475	1.424	1,735	46,300	0.013	0.016	1232	1-1009
Bobolink	1431	45/7	0.178	0.119	0.357	1.427	1,611	38,300	0.012	0.015	1272	1-957
Lapwing	1590	45/7	0.188	0.125	0.376	1.504	1,790	42,200	0.011	0.014	1354	1-1019
Falcon	1590	54/19	0.172	0.103	0.515	1.544	2,041	54,500	0.011	0.014	1359	1-1009
Chukar	1780	84/19	0.146	0.087	0.437	1.602	2,071	51,000	0.010	0.013	1453	1-1020
Bluebird	2156	84/19	0.160	0.096	0.481	1.762	2,509	60,300	0.008	0.011	1623	1-020
Kiwi	2167	72/7	0.174	0.116	0.347	1.735	2,300	49,800	0.008	0.011	1607	1-1053

Note:
Conductor temperature at 75°, ambient temperature 25°C, emissivity 0.5, wind 2 ft/sec, in sun.

continued
→

Conductor Information for AAC Conductors

CODE NAME	SIZE	STRANDING	DIAMETER (INCHES)	WEIGHT PER 1000 FT	RATED STRENGTH	RESISTANCE OHMS PER 1000 FT		ALLOWABLE AMPACITY ¹	SAG10 [®] CHART NO.
	KCMIL	AL	COMPLETE CABLE	LBS	LBS	DC @ 20°C	AC @ 75°C	AMPS	
Peachbell	6	7	0.184	25	563	0.658	0.805	103	1-918
Rose	4	7	0.232	39	881	0.414	0.506	138	1-918
Iris	2	7	0.292	62	1,350	0.260	0.318	185	1-918
Pansy	1	7	0.328	78	1,640	0.207	0.252	214	1-918
Poppy	1/0	7	0.368	99	1,990	0.164	0.200	247	1-918
Aster	2/0	7	0.414	125	2,510	0.130	0.159	286	1-918
Phlox	3/0	7	0.464	157	3,040	0.103	0.126	331	1-918
Oxlip	4/0	7	0.522	198	3,830	0.082	0.100	383	1-918
Sneezewort	250.0	7	0.567	234	4,520	0.069	0.085	425	1-918
Valerian	250.0	19	0.574	234	4,660	0.069	0.085	426	1-945
Daisy	266.8	7	0.586	250	4,830	0.065	0.079	443	1-918
Laurel	266.8	19	0.592	250	4,970	0.065	0.079	444	1-945
Peony	300.0	19	0.628	281	5,480	0.058	0.071	478	1-945
Tulip	336.4	19	0.665	315	6,150	0.051	0.063	513	1-945
Daffodil	350.0	19	0.679	328	6,390	0.049	0.061	526	1-945
Canna	397.5	19	0.723	373	7,110	0.044	0.053	570	1-945
Goldentuft	450.0	19	0.769	422	7,890	0.038	0.043	616	1-945
Cosmos	477.0	19	0.792	447	8,360	0.036	0.045	639	1-945
Syringa	477.0	37	0.795	447	8,690	0.036	0.045	639	1-1049
Zinnia	500.0	19	0.811	469	8,760	0.035	0.043	658	1-945
Hyacinth	500.0	37	0.814	469	9,110	0.035	0.043	658	1-1049
Dahlia	556.5	19	0.856	522	9,750	0.031	0.038	703	1-945
Mistletoe	556.5	37	0.858	522	9,940	0.031	0.038	704	1-1049
Meadowsweet	600.0	37	0.891	562	10,700	0.023	0.036	738	1-1049
Orchid	636.0	37	0.918	596	11,400	0.027	0.036	765	1-1049
Heuchera	650.0	37	0.928	609	11,600	0.027	0.033	775	1-1049
Verbena	700.0	37	0.963	656	12,500	0.025	0.031	812	1-1049
Flag	700.0	61	0.964	656	12,900	0.025	0.031	812	1-1010
Violet	715.5	37	0.973	671	12,800	0.024	0.030	823	1-1049
Nasturtium	715.5	61	0.975	671	13,100	0.024	0.030	823	1-1010
Petunia	750.0	37	0.997	703	13,100	0.023	0.029	847	1-1049
Cattail	750.0	61	0.998	703	13,500	0.023	0.029	847	1-1010
Arbutus	795.0	37	1.026	745	13,900	0.022	0.027	878	1-1049
Lilac	795.0	61	1.027	745	14,300	0.022	0.027	879	1-1010
Cockscomb	900.0	37	1.092	844	15,400	0.019	0.024	948	1-1049
Snapdragon	900.0	61	1.093	844	15,900	0.019	0.024	948	1-1010

continued
→

Conductor Information for AAC Conductors (cont.)

CODE NAME	SIZE	STRANDING	DIAMETER (INCHES)	WEIGHT PER 1000 FT	RATED STRENGTH	RESISTANCE OHMS PER 1000 FT		ALLOWABLE AMPACITY ¹	SAG10 [®] CHART NO.
			COMPLETE CABLE			LBS	LBS	DC @ 20°C	
Magnolia	954.0	37	1.124	894	16,400	0.018	0.023	982	1-1049
Goldenrod	954.0	61	1.125	894	16,900	0.018	0.023	983	1-1010
Hawkweed	1000.0	37	1.151	937	17,200	0.017	0.022	1,010	1-1049
Camellia	1000.0	61	1.152	937	17,700	0.071	0.022	1,011	1-1010
Bluebell	1033.5	37	1.170	969	17,700	0.017	0.021	1,031	1-1049
Larkspur	1033.5	61	1.171	969	18,300	0.017	0.021	1,032	1-1010
Marigold	1113.0	61	1.216	1,043	19,700	0.016	0.020	1,079	1-1010
Hawthorn	1192.5	61	1.258	1,118	21,100	0.015	0.018	1,124	1-1010
Narcissus	1272.0	61	1.300	1,192	22,000	0.014	0.017	1,169	1-1010
Columbine	1351.5	61	1.340	1,267	23,400	0.013	0.016	1,212	1-1010
Carnation	1431.0	61	1.378	1,341	24,300	0.012	0.016	1,253	1-1010
Gladiolus	1510.5	61	1.416	1,416	25,600	0.014	0.015	1,294	1-1010
Coreopsis	1590.0	61	1.453	1,490	27,000	0.011	0.014	1,333	1-1010
Jessamine	1750.0	61	1.524	1,640	29,700	0.010	0.013	1,408	1-1010
Cowslip	2000.0	91	1.631	1,875	34,200	0.009	0.012	1,518	1-1157
Sagebrush	2250.0	91	1.730	2,130	37,500	0.008	0.011	1,612	1-1157
Lupine	2500.0	91	1.823	2,366	41,900	0.007	0.010	1,706	1-1157
Bitterroot	2750.0	91	1.912	2,603	46,100	0.006	0.009	1,793	1-1157
Trillium	3000.0	127	1.998	2,839	50,300	0.006	0.008	1,874	1-1032
Bluebonnet	3500.0	127	2.158	3,345	58,700	0.005	0.008	2,024	1-1032

Note:
Conductor temperature at 75°, ambient temperature 25°C, emissivity 0.5, wind 2 ft/sec, in sun.

continued
→

Conductor Information for AAAC Conductors

CODE NAME	SIZE	STRANDING	DIAMETER	WEIGHT PER 1000 FT	RATED STRENGTH	RESISTANCE OHMS PER 1000 FT		ALLOWABLE AMPACITY ¹	SAG10 [®] CHART NO.
	KCMIL	AL	IN	LBS	LBS	DC @ 20°C	AC @ 75°C	AMPS	
Akron	30.58	7	0.198	29	1,110	0.659	0.785	107	1-1068
Alton	48.69	7	0.250	45	1,760	0.414	0.493	143	1-1068
Ames	77.47	7	0.316	72	2,800	0.260	0.310	191	1-1068
Azusa	123.3	7	0.398	115	4,460	0.163	0.195	256	1-1068
Anaheim	155.4	7	0.447	145	5,390	0.130	0.154	296	1-1068
Amherst	195.7	7	0.502	183	6,790	0.103	0.123	342	1-1068
Alliance	246.9	7	0.563	230	8,560	0.082	0.097	395	1-1068
Butte	312.8	19	0.642	292	11,000	0.064	0.077	460	1-1056
Canton	394.5	19	0.720	368	13,300	0.051	0.061	532	1-1056
Cairo	465.4	19	0.783	434	15,600	0.043	0.052	590	1-1056
Darien	559.5	19	0.858	522	18,800	0.036	0.043	663	1-1056
Elgin	652.4	19	0.927	608	21,900	0.031	0.037	729	1-1056
Flint	740.8	37	0.990	691	24,400	0.027	0.033	790	1-1155
Greeley	927.2	37	1.108	865	30,500	0.022	0.026	908	1-1155

Note:
 Conductor temperature at 75°, ambient temperature 25°C, emissivity 0.5, wind 2 ft/sec, in sun.

continued
 →

Conductor Information for ACAR Conductors

SIZE	STRANDING	DIAMETER	WEIGHT PER 1000 FT	RATED STRENGTH	RESISTANCE		ALLOWABLE AMPACITY ¹	SAG10 [®] CHART NO.
					OHMS PER 1000 FT			
KCMIL	AAC/AAAC	IN	LBS	LBS	DC @ 20°C	AC @ 75°C	AMPS	
355.0	12/7	0.683	332	8,500	0.051	0.062	519	1-1196
465.9	12/7	0.783	436	11,000	0.039	0.048	616	1-1196
503.6	12/7	0.814	471	11,900	0.036	0.044	646	1-1196
653.1	12/7	0.927	611	15,400	0.028	0.034	760	1-1196
739.8	30/7	0.990	693	15,300	0.024	0.030	831	1-1203
739.8	18/19	0.990	692	18,800	0.025	0.031	814	1-1206
853.7	30/7	1.063	799	17,500	0.021	0.026	907	1-1203
853.7	18/19	1.063	798	21,500	0.022	0.027	890	1-1206
927.2	30/7	1.108	868	19,000	0.019	0.024	955	1-1203
927.2	18/19	1.108	867	23,400	0.020	0.025	936	1-1206
1024.5	30/7	1.165	959	20,900	0.017	0.022	1,015	1-1203
1024.5	18/19	1.165	958	25,800	0.018	0.023	995	1-1206
1081.0	30/7	1.196	1,012	22,100	0.016	0.021	1,048	1-1203
1081.0	18/19	1.196	1,011	27,200	0.017	0.021	1,028	1-1206
1109.0	30/7	1.212	1,038	22,700	0.016	0.020	1,065	1-1203
1109.0	18/19	1.212	1,037	27,900	0.017	0.021	1,044	1-1206
1172.0	30/7	1.246	1,097	24,000	0.015	0.019	1,101	1-1203
1172.0	18/19	1.246	1,096	29,500	0.016	0.020	1,080	1-1206
1197.0	30/7	1.259	1,121	24,500	0.015	0.019	1,115	1-1203
1197.0	18/19	1.259	1,119	30,200	0.016	0.019	1,094	1-1206
1280.0	30/7	1.302	1,199	26,200	0.014	0.018	1,160	1-1203
1280.0	18/19	1.302	1,197	32,200	0.015	0.018	1,139	1-1206
1361.0	42/19	1.344	1,274	30,300	0.013	0.017	1,196	1-1125
1527.0	42/19	1.424	1,429	33,600	0.012	0.015	1,314	1-1125
1703.0	42/19	1.504	1,594	37,500	0.011	0.014	1,363	1-1125
1933.0	42/19	1.602	1,809	42,500	0.009	0.012	1,465	1-1125
2267.0	42/19	1.735	2,142	49,900	0.008	0.011	1,594	1-1125
2339.0	42/19	1.762	2,210	51,500	0.008	0.011	1,622	1-1125
2493.0	72/19	1.821	2,357	50,400	0.007	0.010	1,687	1-1235
2493.0	54/37	1.821	2,355	57,600	0.007	0.010	1,670	1-1105

Note:
 Conductor temperature at 75°, ambient temperature 25°C, emissivity 0.5, wind 2 ft/sec, in sun.

Installation Instructions

Standard Compression Dead End for ACSR and ACSS Conductor

CAUTION: ACSR Dead Ends Cannot Be Used on ACSS HT Conductor

1. Mark the conductor a distance of $\frac{3}{4}$ the length of the aluminum body (**Figure 1**).
2. Prior to making connection, the outer strands of the conductor must be cleaned with a wire brush or abrasive cloth (**Figure 2**).
3. Prior to any strand cutting, tape the end of the conductor to help maintain the round contour.
4. Slide the aluminum dead end body over conductor until sufficient working length protrudes from tongue end. (**Figure 3**).
5. Cut back aluminum strands equal to the depth of the steel forging barrel plus 1 inch (25.4 mm). Do not nick the steel strands. File burrs, if present. (**Figure 4**). Use of a cable trimming tool is recommended. (**Figure 4a, 4b**).
6. Insert steel core into steel barrel to full length of bore. (**Figure 5**).
7. Using the proper SH die set, compress steel barrel full length making initial compression adjacent to rib closest to barrel. Overlap each successive compression by at least $\frac{1}{4}$ inch (6.4 mm). Complete die closure is required on all compressions. (**Figure 5a, 5b**).
8. Slide the aluminum body over the steel forging until the tongue end butts solidly against felt washer and shoulder of steel eye. Align eye with tongue to desired orientation for attachment to insulator string. (**Figure 6**).



FIGURE 1: Mark the conductor and clean $\frac{3}{4}$ the length of the aluminum body.

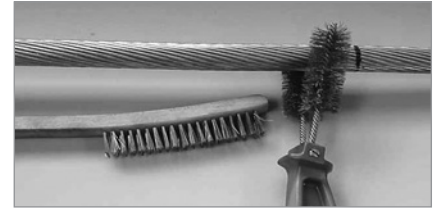

FIGURE 2: Clean a distance of at least $\frac{3}{4}$ the distance of the aluminum dead end body.



FIGURE 3: Slide aluminum dead end body over conductor.

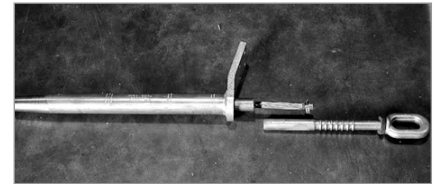

FIGURE 4:



FIGURE 4a:



FIGURE 4b:



FIGURE 5:



FIGURE 5a:



FIGURE 5b:



FIGURE 6:

Installation Instructions (cont.)

Standard Compression Dead End for ACSR and ACSS Conductor

- Inject filler compound (AFC or AFCHT for HiTemp®) into filler hole until compound emerges at felt washer and tapered end of aluminum body. (**Figure 6a**).

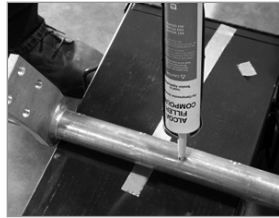

FIGURE 6a:

- Insert and drive filler plug (cavity up) into hole and peen edge of hole over top surface of plug. (**Figure 7**). Leaving the filler plug in the small plastic bag makes it easier to insert when working with gloves. (**Figure 7a**).

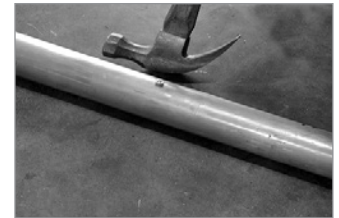

FIGURE 7:

- Using the proper AH die set, make the initial compression on the aluminum body beginning at the “start” mark nearest the tongue. Overlap each successive compression by at least ¼ inch (6.4 mm). Press only to the “stop” mark. Complete die closure is required for each compression. (**Figure 8**).



FIGURE 7a:



FIGURE 8:

Note: A light oil coating on the die grooves and aluminum sleeve is recommended.

- To press the dead end body over the conductor, use the same die used in step 11. Begin compressing at the “start” mark about centrally located. Overlap each successive compression by at least ¼ inch (6.4 mm). Press to the end of the body, including the tapered portion. Complete die closure is required on each compression. (**Figure 9**).

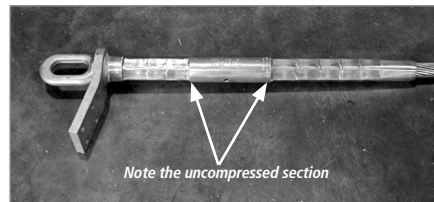

FIGURE 9:

During this compression sequence, the plastic bag in which the dead end assembly was received can be used as a medium between the aluminum body and dies (instead of oil as mentioned in step 11).



FIGURE 10:

- Compressed portion of dead end body should have a smooth uniform appearance. (**Figure 10**). If die flash is present, remove with a file or emery cloth.
- Remove any excess filler compound which may have been forced out the end of the dead end body.

Installation Instructions

Adjustable Compression Dead Ends on ACSR Conductors

1. Prior to making connections, the outer strand on all conductors (even new conductors) must be cleaned with a wire brush or abrasive cloth. If the conductor is weathered or blackened, carefully unlay aluminum strands for a distance equal to or greater than 3/4 the length of the aluminum dead end body and clean strands thoroughly with wire brush or abrasive cloth. Check accessory bore for foreign particles, removing if present.
2. Serve the conductor, prior to cutting, with tape to help maintain the round contour making it easier to slide the end through the aluminum dead end.
3. Straighten several feet of conductor removing set caused by reel (if necessary).
4. If a comealong is being used, it should be located at least ten (10) feet from end of conductor.
5. Slide dead end body over conductor until sufficient working length protrudes from tongue end.
6. Cut back aluminum strands a distance equal to the depth of the bore of the steel forging barrel plus 1 inch. Do not nick steel strands. File burrs as necessary for ease of insertion.
7. Insert steel core into steel barrel to full length of bore.
8. Select die size for compressing steel barrel. The die size on the die and die size marked on steel barrel must be the same.
9. Compress steel barrel full length making initial compression adjacent to corrugations. Overlap each successive compression by approximately 1/4 die bite. Complete die closure is required for each compression.
10. Remove any remaining tape from the aluminum strands and slide aluminum dead end body over steel forging until tongue end butts solidly against felt washer and shoulder of steel dead end. Align clevis or eye with tongue of dead end to ensure proper positioning when dead end is fastened to insulator hardware.
11. Inject AFL Filler Compound (AFC) into filler hole until compound emerges at the felt washer and the tapered end of the body. Insert and drive filler plug into hole and peen edge of hole over top surface of plug.
12. Select die size to compress aluminum dead end body. Die size for aluminum dead end body and die size marked on die must be the same.
13. It is recommended that die grooves be well lubricated with a light weight oil. Oil coating should be maintained during entire compression operation.
14. Make the initial compression on the dead end body over the steel shank beginning at the "start knurl" nearest the dead end tongue. Continue making compressions to the "stop knurl", overlapping the previous compression by approximately 1/4 die bite. Complete die closure is required for each compression.
15. To press the dead end body over the conductor, use the same die used in step 13. Make the initial compression at the "start knurl" and proceed with compression. Continue making compressions to the end of the dead end body, overlapping the previous compression by approximately 1/4 die bite. Complete die closure is required for each compression.
16. Note there should be an uncompressed area on the dead end body where it covers the compressed barrel of the steel forging (area of the filler plug).
17. Compressed portion of the dead end should have a smooth uniform appearance. Remove flash, if present, with file or emery cloth.

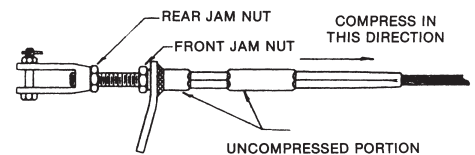
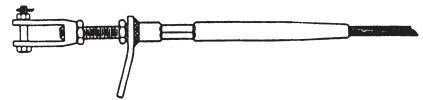
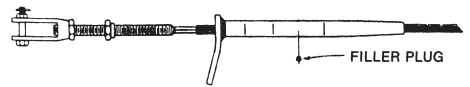
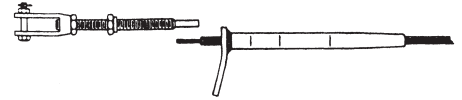
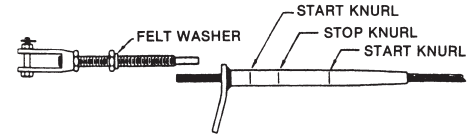

CAUTION: Follow installation instructions carefully. Improper installation can result in mechanical failure of the cable system and possible injury to persons handling or in the vicinity of the cable systems.

SAFETY: Consult your safety training department to ensure that the installation procedure adopted is in compliance with your company's standard procedure.

Installation Instructions

Clevis Adjustment of Adjustable Compression Dead Ends on ACSR Conductors

Standard Method

1. Loosen rear jam nut.
2. Rotate clevis for proper sag and tension.
3. Tighten rear jam nut.

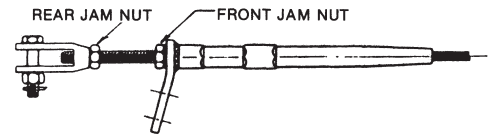

CAUTION: Follow installation instructions carefully. Improper installation can result in mechanical failure of the cable system and possible injury to persons handling or in the vicinity of the cable systems.

SAFETY: Consult your safety training department to ensure that the installation procedure adopted is in compliance with your company's standard procedure.

Installation Instructions

Standard Compression Terminals

(These instructions are not for HiTemp® Conductors)

1. Prior to making any connections, the conductor must be clean. For new conductor, the outside diameter shall be wire brushed to remove the aluminum oxidation. If the conductor is weathered or blackened, carefully unlay the aluminum strands for a distance equal to the compression length of the terminal. Clean all of the aluminum strands thoroughly with a wire brush.
2. Mark the conductor from the end, a distance equal to the compression length of the terminal.

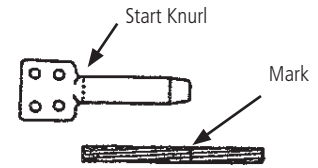

Quick Compress:

- 3a. Insert the conductor into the terminal. Be sure the conductor is inserted to the mark on the conductor. The terminal comes pre-filled with compound from the factory.

Standard Compression:

- 3b. Inject sufficient AFL Filler Compound (AFC) in the end of the terminal bore and on the conductor to ensure that excess compound will be visible at terminal end when barrel is completely compressed. See chart below for proper amount of AFC required for each terminal size.



AFC Filler Compound Required

PARTIAL TERMINAL CATALOG NUMBER	LB.	GRAMS (G)
5172., 5672., 5872.	0.01	5
5173., 5673., 5873.	0.01	5
5174., 5674., 5874.	0.02	9
5175., 5675., 5875.	0.02	9
5176., 5676., 5876.	0.02	9
5106., 5606., 5806.	0.02	9
5109., 5609., 5809.	0.02	9
5110., 5610., 5810.	0.03	14
5111., 5611., 5811.	0.03	14
5112., 5612., 5812.	0.03	14
5113., 5613., 5813.	0.03	14
5120., 5620., 5820.	0.04	18
5124., 5624., 5824.	0.05	23
5127., 5627., 5827.	0.06	27
5130., 5630., 5830.	0.09	41
5134., 5634., 5834.	0.12	54
5136., 5636., 5836.	0.15	68
5138., 5638., 5838.	0.17	77
5140., 5640., 5840.	0.2	91
5142., 5642., 5842.	0.24	109
5144., 5644., 5844.	0.28	127
5148., 5648., 5848.	0.32	145

CAUTION: Follow installation instructions carefully. Improper installation can result in mechanical failure of the cable system and possible injury to persons handling or in the vicinity of the cable systems.

Installation Instructions (cont.)

Standard Compression Terminals

(These instructions are not for HiTemp® Conductors)

4. To compress, select the proper die size as stamped on the jumper connector.
5. Compress the terminal, beginning at the "start knurl." Continue compressing toward the end of the terminal. Complete die closure is required for each compression. Overlap the previous compression by approximately 1/4 die bite. It is recommended that die grooves be well lubricated with a lightweight oil. Oil coating should be maintained during entire compression operation. (Other acceptable mediums that can be used instead of oil are wax, soap or plastic bag the terminal was shipped in.)
6. Remove flash, if any, with a file or an abrasive cloth.

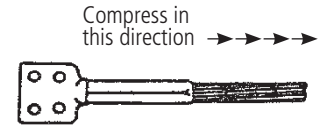

To Attach Terminal Connector to Dead End or Tee Tap

7. Clean contact surface of pads to be connected by wire brushing thoroughly and immediately coating with a thin film of No. 2 Electrical Joint Compound (EJC). Do not use AFC.
8. Bolt terminal to dead end pad. Partially tighten all bolts and then re-tighten each bolt to the recommended torque:

Aluminum 1/2" bolts - 25 lb-ft (34 N.m)
Stainless Steel 1/2" bolts - 40 lb-ft (54 N.m)

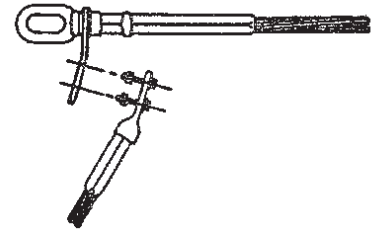

CAUTION: Follow installation instructions carefully. Improper installation can result in mechanical failure of the cable system and possible injury to persons handling or in the vicinity of the cable systems.

Installation Instructions

Adjustable and Non-Adjustable Compression Dead Ends on AAC, AAAC, ACAR and AWAC Conductors

- Prior to making connections, the conductor must be wire brushed and accessory bore must be clean. If the conductor is weathered or blackened, carefully unlay aluminum strands for a distance equal to or greater than 1/4 the length of the aluminum dead end body and clean strands thoroughly with wire brush or abrasive cloth. Check accessory bore for foreign particles and remove if present.
- Straighten several feet of conductor removing set caused by reel.
- Coat the steel dead end shank with a liberal quantity of AFL Filler Compound (AFC).
- Insert steel dead end shank into tongue end of aluminum body until the felt washer butts solidly against the front jam nut on the clevis rod of the adjustable clevis or shoulder of non-adjustable steel dead end.
- For non-adjustable steel dead ends, align the steel eye or clevis with the tongue of the aluminum dead end body to ensure that the tongue will be in proper position when the dead end is fastened to insulator hardware.
- Select die size to compress aluminum dead end body. Die size for aluminum dead end and die size marked on die must be the same.
- It is recommended that die grooves be well lubricated with a light weight oil. Oil coating should be maintained during entire compression operation.
- Make the initial compression on the dead end body over the steel shank beginning at the "start knurl" nearest the dead end tongue. Continue making compressions to the "stop knurl", overlapping the previous compression by approximately 1/4 die bite. Complete die closure is required for each compression.
- Insert conductor full depth into dead end body and mark conductor at end of barrel. Remove conductor after marking.
- Inject sufficient AFL Filler Compound (AFC) In the end of the dead end bore and on the conductor to ensure that excess compound will be visible at the end of the dead end body when the barrel, is completely compressed.
- Insert clean end of the conductor into the dead end body to the mark on the conductor.
- The dead end will bow during compression unless reasonable care is taken to have about 15 ft. (4.5 m) of the conductor supported straight out from the end of the dead end such that the weight of the conductor does not hang unsupported from the end of the dead end when compressing.
- To press the dead end body over the conductor, use the same die used in step 8. Make the initial compression at the "start knurl" nearest the end of the dead end body. Continue making compressions to the end of the dead end body, overlapping the previous compression by approximately 1/4 die bite. Complete die closure is required for each compression.
- Compressed portion of the dead end should have a smooth uniform appearance. Remove flash, if present, with file or emery cloth.

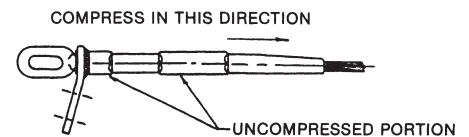
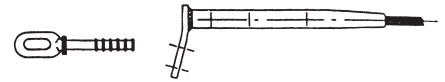
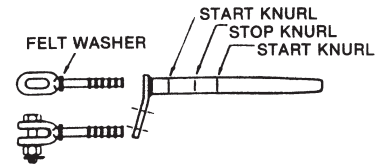

CAUTION: Follow installation instructions carefully. Improper installation can result in mechanical failure of the cable system and possible injury to persons handling or in the vicinity of the cable systems.

SAFETY: Consult your safety training department to ensure that the installation procedure adopted is in compliance with your company's standard procedure.

Installation Instructions

Compression Dead Ends on EHS ACSR, Alumoweld® and Steel Ground Wire

1. Serve the conductor, prior to cutting, to help maintain the round contour. File burrs or shape edges off the conductor as necessary for ease of insertion.
2. Straighten several feet of conductor removing set caused by reel.
3. Slide the aluminum filler sleeve over conductor.
4. Slide the aluminum dead end body over conductor; tapered end first.
5. Select the die size for compressing the steel barrel. The die size marked on the die and the die size marked on the steel dead end must be the same.
6. Insert the conductor into the bore of the steel dead end.
7. Compress the steel barrel full length making initial compression adjacent to the corrugations. Overlap each successive compression by approximately 1/4 die bite. Complete die closure is required for proper compression.
8. Slide the aluminum dead end body over steel forging until the end butts solidly against the felt washer.
9. Slide the aluminum filler sleeve into the aluminum dead end body until the ends of the filler sleeve and the aluminum dead end body are flush.
10. Inject AFL Filler Compound (AFC) into filler hole until compound emerges at the felt washer. Insert and drive filler plug into hole andpeen edge of hole over top surface of plug.
11. Select the die size to compress the aluminum dead end body. The die size for the aluminum dead end body and the size marked on the die must be the same.
12. It is recommended that die grooves be well lubricated with a light weight oil. Oil costing should be maintained during entire compression operation.
13. Make the initial compression on the dead end body over the steel shank beginning at the "start knurl" nearest the eye or clevis. Continue making compressions to the "stop knurl" overlapping the previous compression by 1/4 die bite. Complete die closure is required for each compression.
13. To press the dead end body and filler sleeve over the conductor, use the same die used in step 13. Make the initial compression at the "start knurl" nearest the end of the dead end body. Complete die closure is required for each compression.
14. The compressed portion of the dead end should have a smooth uniform appearance. Remove flash, if present, with file or emery cloth.

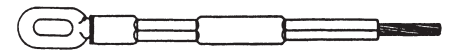
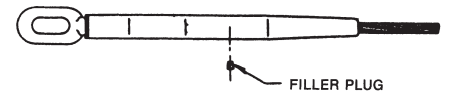
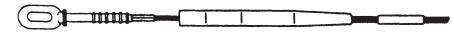
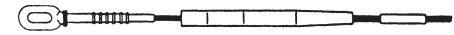
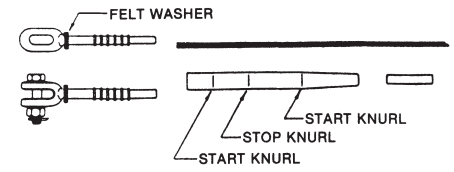

CAUTION: Follow installation instructions carefully. Improper installation can result in mechanical failure of the cable system and possible injury to persons handling or in the vicinity of the cable systems.

Installation Instructions

Bolted Jumper Connectors on Alumoweld® and Steel Ground Wire

Standard Method

1. Clean conductor and grooves of the bolted jumper. If installation is to be made on old cable, clean strands with a wire brush or emery cloth.
2. Coat the clamp groove and conductor liberally with No. 2 Electrical Joint Compound (EJC). DO NOT USE AFL FILLER COMPOUND (AFC).
3. Bolt conductor in groove, partially tighten nuts, then re-tighten each nut to recommended torque. (3/8" bolt-15 lbf-ft (20 N.m); 1/2" bolt-25 lbf-ft (34 N.m))
4. DO NOT remove the EJC that squeezes out when clamp is tightened.

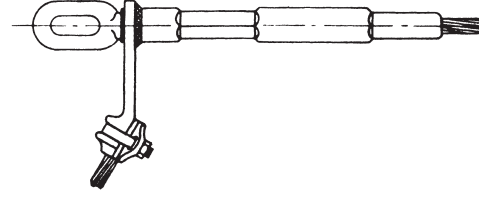

CAUTION: Follow installation instructions carefully. Improper installation can result in mechanical failure of the cable system and possible injury to persons handling or in the vicinity of the cable systems.

Installation Instructions

Terminal Connectors on Alumoweld® and Steel Ground Wire

Standard Method

1. Insert conductor full depth into terminal bore and mark conductor at end of barrel. Remove conductor after marking.
2. Inject sufficient AFL Filler Compound (AFC) in the end of the terminal bore and on the conductor to ensure that excess compound will be visible at terminal and when barrel is completely compressed.
3. Insert clean end of the conductor into the terminal barrel to the mark on the conductor.
4. Select die size for compressing aluminum terminal. The die size on die and die size marked on the terminal must be the same.
5. Make initial compression starting at "start knurl". Continue making compressions to the mouth of the terminal overlapping the previous compression by approximately 1/4 die bite. Complete die closure is required for each compression. Compressed portion of the terminal should have a smooth uniform appearance. Remove flash, if present, with file or emery cloth.
6. Clean contact surface of terminal and of dead end pad by wire brushing through No. 2 Electrical Joint Compound (EJC). DO NOT USE AFL FILLER COMPOUND (AFC).
7. Bolt terminal to dead end pad. Partially tighten all bolts and then re-tighten each bolt to recommended torque. 1/2" bolt-25 lbf-ft (34 N.m); 5/8" bolt-40 lbf-ft (54 N.m)

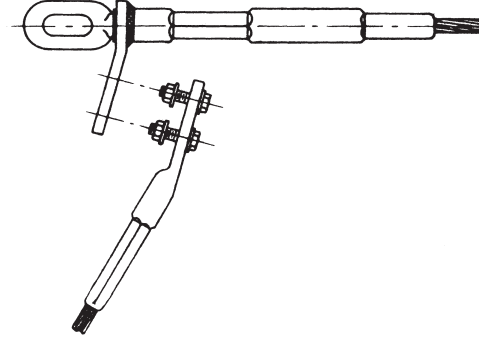

CAUTION: Follow installation instructions carefully. Improper installation can result in mechanical failure of the cable system and possible injury to persons handling or in the vicinity of the cable systems.

Installation Instructions

Standard Compression Splice for ACSR

1. Mark the conductor a distance of $\frac{1}{2}$ the length of the aluminum sleeve (**Figure 1**).
2. Prior to making connection, the outer strands of the conductor should be cleaned with a wire brush or abrasive cloth (**Figure 2**).
3. Remark each conductor half the length of the aluminum sleeve, if the mark was removed during wire brushing. Prior to any strand cutting, tape the end of each conductor to help maintain the round contour (**Figure 3**).
4. Slide the aluminum sleeve over one conductor until sufficient working length protrudes from end (**Figure 4**).
5. Cut back aluminum strands of both conductors $\frac{1}{2}$ the length of the steel sleeve plus 1 inch (25.4 mm). Do not nick the steel strands. File any burrs, if present (**Figure 5a**). Use of a cable trimming tool is recommended (**Figure 5b**).
6. Insert ends of steel core into steel sleeve making sure the ends butt solidly against center stop (**Figure 6**).
7. Using the proper SH die set, compress steel sleeve full length making initial compression over center of sleeve (**Figure 7a**), Overlap each successive compression by at least $\frac{1}{4}$ inch (6.4 mm) (**Figure 7b**). Complete die closure is required on all compressions.



FIGURE 1: Mark the conductor and clean 1/2 the length of the sleeve.

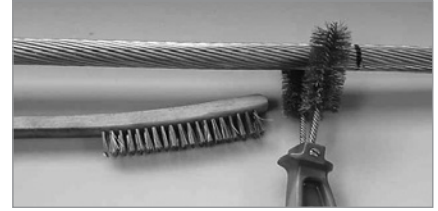

FIGURE 2: Clean the outer strands of the conductor with a wire brush.

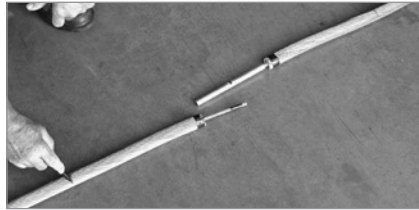

FIGURE 3: Re-mark the conductors after cleaning if needed.

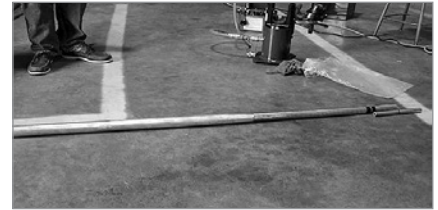

FIGURE 4: Slide sleeve over one conductor so it protrudes out the end.

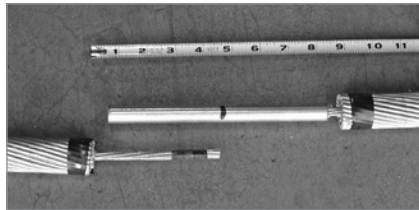

FIGURE 5a: Cut back the Aluminum strands on both conductors 1/2 the length of the Steel sleeve plus 1 inch (25.4 mm).

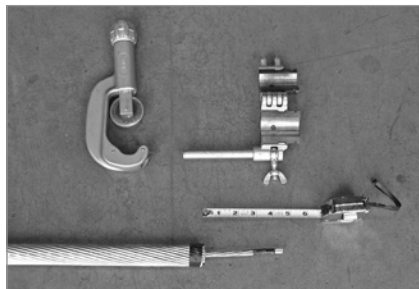
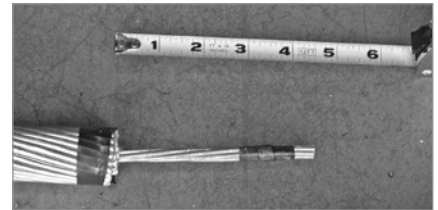

FIGURE 5b: Use of a cable trimming tool is recommended.



FIGURE 6: Slide sleeve over one conductor so it protrudes out the end.

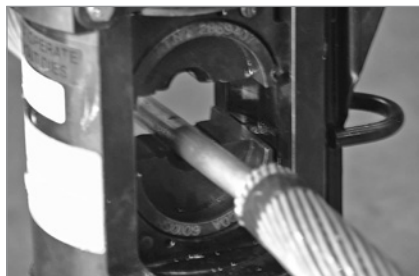

FIGURE 7a: Make the initial compression on center of Steel sleeve.



FIGURE 7b: Overlap each compression on Steel sleeve 1/4 inch (6.4 mm).

Installation Instructions (cont.)

Standard Compression Splice for ACSR

8. Slide the aluminum sleeve over the installed steel sleeve, centering between the two marks that were made in **Step 3 (Figure 8a & 8b)**.
9. Inject AFC filler compound into the filler hole until compound emerges from both ends of aluminum sleeve (**Figure 9**).
10. Insert and drive filler plug (cavity up) into hole and peen edge of hole over top surface of plug. Leaving the filler plug in the small plastic bag makes it easier to insert when working with gloves (**Figure 10a, 10b & 10c**).
11. Using the proper AH die set, make the initial compression at the "start" mark on one side of center (**Figure 11a**). The second compression should be made at the other "start" mark on opposite side of center. Continue making compressions to the end, overlapping each by at least 1/4 inch (6.4 mm) (**Figure 11b**). Repeat this on opposite side of joint (**Figure 11c**). Complete die closure is required for each compression.

Note: A light oil coating on the die grooves and aluminum sleeve is recommended.

12. Compressed portion of splice sleeve should have a smooth uniform appearance. If die flash is present, remove with a file or emery cloth (**Figure 12**). Remove any excess filler compound which may have been forced out the ends of the splice.

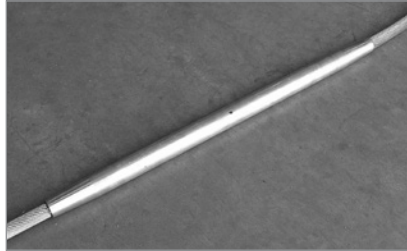

FIGURE 8a: Slide the Aluminum sleeve over the installed Steel sleeve.

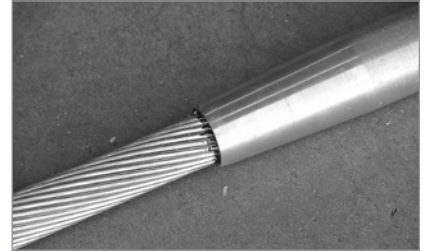

FIGURE 8b: Center the Aluminum sleeve between the marks.



FIGURE 9: Inject AFC Filler Compound into the filler hole.



FIGURE 10a: Peen edge of filler hole over top surface of plug.

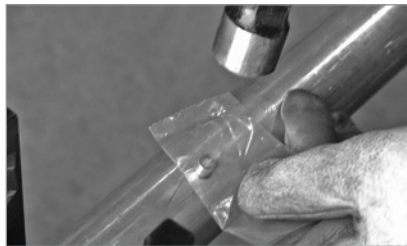

FIGURE 10b: Filler plug left in plastic bag is easier to insert with gloves.

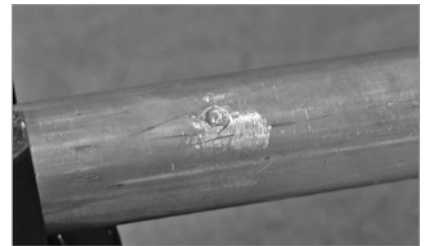

FIGURE 10c: Peen edge of filler hole over top surface of plug.



FIGURE 11a: Make the initial compression at the "start" mark.



FIGURE 11b: Overlap each compression by 1/4 inch (6.4 mm).



FIGURE 11c: Completed compression splice.

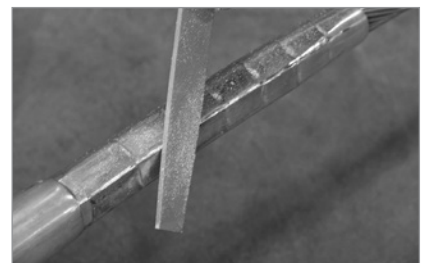
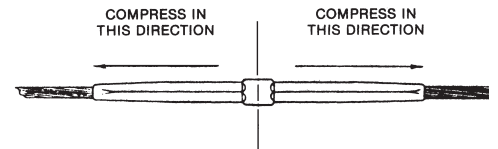
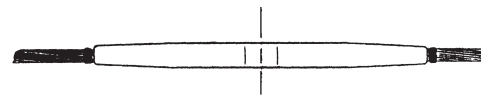
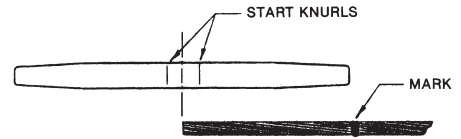

FIGURE 12: If die flash is present, remove with a file or emery cloth.

Installation Instructions

Compression Joints on AAC, AAAC, ACAR and AWAC Conductors

1. Measure back from each conductor end and mark at a distance equal to $\frac{1}{2}$ the length of the aluminum joint.
2. File burrs or sharp edges off the aluminum strands as necessary for ease of insertion.
3. Prior to making connections, the conductor must be wire brushed and accessory bores must be clean. If the conductor is weathered or blackened, carefully unlay aluminum strands for a distance equal to or greater than $\frac{1}{2}$ the length of the aluminum joint and clean strands thoroughly with wire brush or abrasive cloth. Check accessory bore for foreign particles, removing if present.
4. Straighten several feet of conductor removing Set caused by reel.
5. Inject AFL Filler Compound (AFC) into each end of joint and on the conductor to ensure that excess compound will be forced from the barrel when compressions are completed. Insert conductor ends into the joint. If the mark on the conductor is not at end of the joint, and there is resistance to further entry, twist the joint on the conductor. This will work the compound between conductor strands and bleed air from the joint.
6. Select die size for compressing joint. The die size on die and die size marked on aluminum joint must be the same.
7. The joint will bow during compression unless reasonable care is taken to have about 15 ft. (4.5 m) of the conductor supported straight out from both ends of the joint such that the weight of the conductor does not hang unsupported from the end of the joint when compressing.
8. Make initial compression on either side of joint starting at the "start knurl". Make the second compression on the opposite end of the joint at the other "start knurl". Continue making compressions to one end of joint overlapping the previous compression by approximately $\frac{1}{4}$ die bite. Complete die closure is required for each compression. Go back and complete the compressions on the opposite end. The center portion of the joint, approximately one inch, is not compressed. It is recommended that die grooves be well lubricated with a light weight oil. Oil coating should be maintained during entire compression operation.
9. Compressed portion of the joint should have a smooth uniform appearance. Remove flash, if present, with file or emery cloth.



CAUTION: Follow installation instructions carefully. Improper installation can result in mechanical failure of the cable system and possible injury to persons handling or in the vicinity of the cable systems.

Installation Instructions

Compression Joints on AWAC, Alumoweld® and Steel Ground Wire

1. Measure back from each conductor end and mark at a distance equal to $\frac{1}{2}$ the length of the aluminum joint.
2. File burrs or sharp edges off the conductor strands as necessary for ease of insertion.
3. Prior to making connections, the conductor must be clean. If the conductor is weathered or blackened, clean strands thoroughly with wire brush or abrasive cloth.
4. Straighten several feet of conductor, removing set caused by reel.
5. Insert conductor ends into the joint. If the mark on the conductor is not at the end of the joint, and there is resistance to further entry, twist the joint on the conductor. This will work the compound between conductor strands and bleed air from the joint. (Joints are prefilled so additional AFL Filler Compound (AFC) should not be required.)
6. Select die size for compressing joint. Die size on die and die size marked on aluminum joint must be the same.
7. The joint will bow during compression unless reasonable care is taken to have about 15 ft. (4.5 m) of the conductor supported straight out from both ends of the joint such that the weight of the conductor does not hang unsupported from the end of the joint when compressing.
8. Make initial compression on either side of the joint starting at the "start knurl". Make the second compression on the opposite end of the joint at the other "start knurl". Continue making compressions to one end of joint overlapping the previous compression by approximately $\frac{1}{4}$ die bite. Complete die closure is required for each compression. Go back and complete the compressions on the opposite end. The center portion of the joint, approximately one inch, is not compressed. It is recommended that die grooves be well lubricated with a light weight oil. Oil coating should be maintained during entire compression operation.
9. Compressed portion of the joint should have a smooth appearance. Remove flash, if present, with file or emery cloth.
10. Single piece compression joints (jiffy joints) for ACSR, ACAR, AWAC and alloy conductors follow the procedure above.

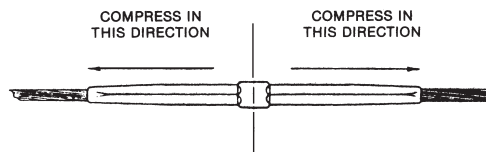
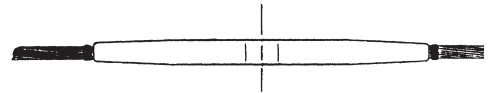
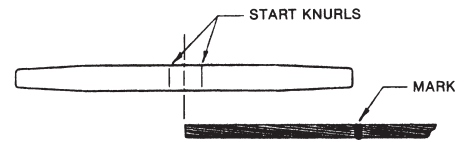

CAUTION: Follow installation instructions carefully. Improper installation can result in mechanical failure of the cable system and possible injury to persons handling or in the vicinity of the cable systems.

Installation Instructions

Compression Joints on Extra High Strength ACSR Conductors

1. Measure back from each conductor end and mark at a distance equal to $\frac{1}{2}$ the length of the aluminum joint.
2. Prior to making connections, the conductor must be wire brushed and accessory bore must be clean. If the conductor is weathered or blackened, carefully unlay aluminum strands for a distance equal to or greater than $\frac{1}{2}$ the length of the aluminum joint and clean strands thoroughly with wire brush or abrasive cloth. Check accessory bore for foreign particles, removing if present.
3. Prior to cutting, serve the conductor with tape to help maintain the round contour making it easier to slide the end through the joint and filler sleeve.
4. Straighten several feet of conductor removing set caused by reel.
5. Slide the aluminum filler sleeve over conductor end beyond mark.
6. Slide the aluminum joint over other conductor end beyond mark. End with staked if filler sleeve first.
7. Cutback aluminum strands on each conductor end a distance equal to $\frac{1}{2}$ the length of the steel joint plus one inch (25.4 mm). Do not nick steel strands. File burrs as necessary for ease of insertion.
8. Insert ends of steel core into the steel joint making sure the ends butt solidly against center stop.
9. Select die size for compression steel joint. The die size on die and die size marked on steel joint must be the same.
10. Compress steel joint full length making initial compression over center stop. Overlap each successive compression by approximately $\frac{1}{4}$ die bits. Complete die closure is required for each compression.
11. Remove tape from ends of aluminum strands. Slide the aluminum joint over the installed steel joint and center between the two marks on the cable.
12. Slide the aluminum filler sleeve into the aluminum joint until ends of the filler sleeve and aluminum joint are flush.
13. Inject AFL Filler Compound (AFC) into filler hole at end of joint until compound is visible at both ends of joint. Insert drive filler plug into hole and peen edge of hole over top surface of plug.
14. Select die size to compress aluminum joint. Die size for aluminum joint and die size marked on die must be the same.
15. The joint will bow during compression unless reasonable care is taken to have about 15 ft. (4.5 m) of the conductor supported straight out from both ends of the joint such that the weight of the conductor does not hang unsupported from the end of the joint when compressing.
16. Make initial compression on either side of joint starting at the "start knurl". Make the second compression on the opposite end of the joint at the other "start knurl". Continue making compressions to one end of the joint overlapping the previous compression by approximately $\frac{1}{4}$ die bite. Complete die closure is required for each compression. Go back and complete the compression on the opposite end. The center portion of the joint is not compressed. It is recommended that die grooves be well lubricated with a light weight oil. Oil coating should be maintained during entire compression operation.
17. Compressed portion of the joint should have a smooth uniform appearance. Remove flash, if present, with file or emery cloth.

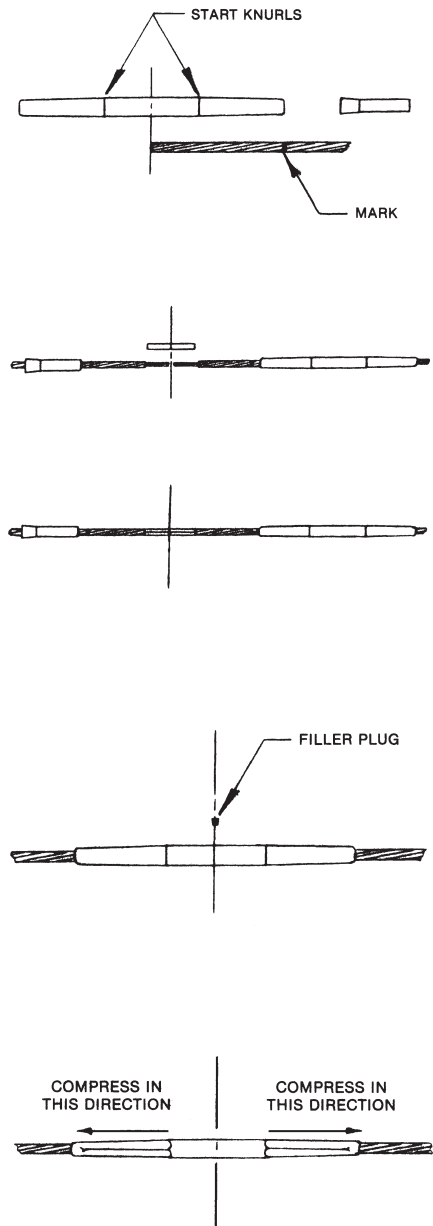

CAUTION: Follow installation instructions carefully. Improper installation can result in mechanical failure of the cable system and possible injury to persons handling or in the vicinity of the cable systems.

Installation Instructions

Standard Compression Repair Sleeves on ACSR, AAC, AAAC and ACAR Conductors

1. Compression Repair Sleeves can be used to restore the electrical and mechanical integrity of a conductor when no more than 1/3 of the aluminum strands are damaged.
2. Mark the conductor from the damaged area 1/2 the length of the repair sleeve.
3. Select die size for compressing the repair sleeve. The die size on the die and the die size marked on the repair sleeve must be the same.
4. Prior to making connections, the groove of the aluminum accessories and the conductor must be clean. If the conductor is weathered or blackened, clean strands thoroughly with wire brush. Check accessory groove for foreign particles, removing if present.
5. Coat the aluminum conductor with AFL Filler Compound (AFC) over the length to be covered by the repair sleeve.
6. Place the repair sleeve groove on the conductor adjacent to damaged area and slide other half (keeper) in place.
7. Slide repair sleeve assembly over the damaged area to the mark on the conductor.
8. Make the initial compression over the center portion of the repair sleeve. Make the second compression on one end overlapping the initial compression by 1/4 die bite. Make the third compression on the opposite end, overlapping the initial compression by 1/4 die bite. Continue making compressions to one end of the repair sleeve overlapping the previous compression by 1/4 die bite. Complete die closure is required for each compression. Go back and complete the compression on the opposite end.
9. The compressed repair sleeve should have a smooth uniform appearance. Remove flash, if present, with file or emery cloth.

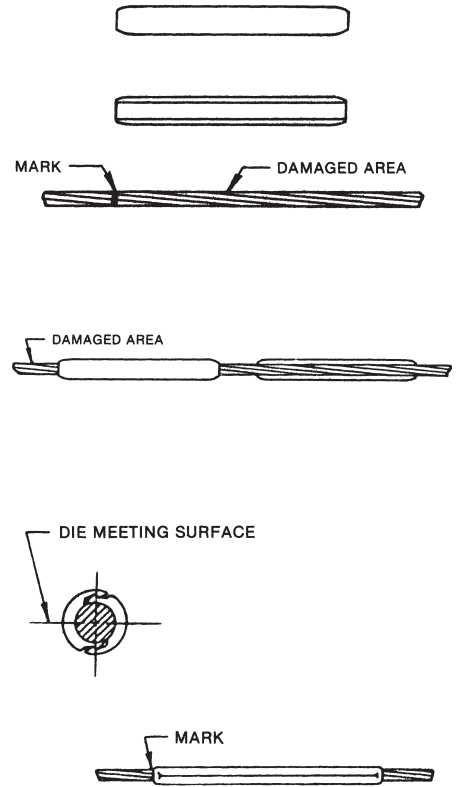

CAUTION: Follow installation instructions carefully. Improper installation can result in mechanical failure of the cable system and possible injury to persons handling or in the vicinity of the cable systems.

Installation Instructions

Standard Compression and Quick Compress® Jumper Connectors on ACSR, AAC, AAAC, ACAR, Alumoweld® and Steel Ground Wire Conductor

1. Measure back from each conductor end and mark at a distance equal to 1/2 the length of the aluminum jumper connector.
2. File burrs or sharp edges off the aluminum strands as necessary for ease of insertion.
3. Prior to making connections, the conductor must be wire brushed and accessory bores must be clean. If the conductor is weathered or blackened, carefully unlay aluminum strands for a distance equal to or greater than 1/2 the length of the aluminum jumper connector and clean strands thoroughly with wire brush. An alternate way to thoroughly clean the aluminum oxidation from the conductor is to use the ConductaClean® system. Check accessory bore for foreign particles, removing if present.
4. Inject AFL Filler Compound (AFC) into each end of jumper connector and on the conductor to insure that excess compound will be forced from the jumper connector when compressions are completed. Insert conductor ends into the jumper connector. If the mark on the conductor is not at the end of the jumper connector, and there is resistance to further entry, twist the jumper connector on the conductor. This will work the compound between conductor strands and bleed air from the jumper connector.
5. Select die size for compressing jumper connector. The die size on die and die size marked on aluminum jumper connector must be the same.
6. The jumper connector will bow during compression unless reasonable care is taken to have about 15 ft. (4.5 m) of the conductor supported straight out from both ends of the jumper connector such that the weight of the conductor does not hang unsupported from the end of the jumper connector when compressing.
7. Compress jumper connector full length making initial compression over center stop. Overlap each successive compression by approximately 1/4 die bite. Complete die closure is required for each compression.
8. Compressed jumper connector should have a smooth uniform appearance. Remove flash, if present, with file or emery cloth.

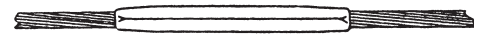
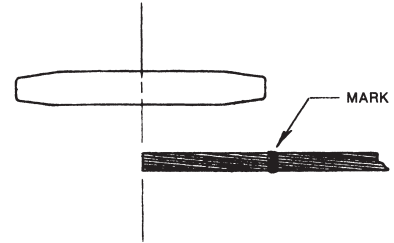

CAUTION: Follow installation instructions carefully. Improper installation can result in mechanical failure of the cable system and possible injury to persons handling or in the vicinity of the cable systems.

Installation Instructions

Open Run Tee Taps and Tee Connectors on ACSR, AAC, AAAC and ACAR Conductors

1. Remove the keeper.
2. Select die size for compressing the aluminum run. The die size on the die and die size marked on the aluminum run must be the same.
3. Prior to making connections, the groove of the aluminum accessories and the conductor must be clean. If the conductor is weathered or blackened, clean strands thoroughly with wire brush or abrasive cloth. Check the accessory groove for foreign particles, removing if present.
4. Coat the aluminum conductor with AFL Filler Compound (AFC) over the length to be covered by the tee tap.
5. Place run groove on conductor and slide the keeper in place.
6. Make initial compression on either side of run starting at the "start knurl". Make the second compression on the opposite end of the run at the "start knurl". Continue making compressions to one end of the tee overlapping the previous compression by approximately 1/4 die bite. Complete die closure is required for each compression. Go back and complete the compression on the opposite end.
7. Compressed portion of tee should have a smooth uniform appearance. Remove flash, if present, with file or emery cloth.
8. See page 131 for terminal installation instructions.

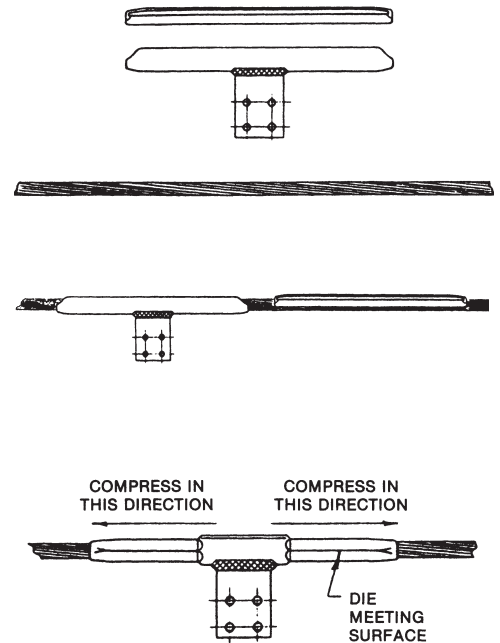

CAUTION: Follow installation instructions carefully. Improper installation can result in mechanical failure of the cable system and possible injury to persons handling or in the vicinity of the cable systems.

Installation Instructions

Open Run Tee Connectors on ACSR, AAC, AAAC and ACAR Conductors

Installation of Tee With Compression Branch

1. Install run tee as before per steps 1-7, page 144.
2. Select die size for compressing aluminum branch. The die size on die and the die size on the branch must be the same.
3. Insert conductor full depth into branch bore and mark conductor at end of branch. Remove conductor after marking.
4. Inject sufficient AFL Filler Compound (AFC) in the end of the branch bore and on the conductor to ensure that excess compound will be visible at the branch end when completely compressed.
5. Insert cleaned end of the conductor into the branch to the mark on the conductor.
6. Make initial compression starting at the "start knurl". Continue making compressions to mouth of the branch overlapping the previous compression by approximately 1/4 die bite. Complete die closure is required for each compression.
7. Compressed portion of the branch should have a smooth uniform appearance. Remove flash, if present, with file or emery cloth.

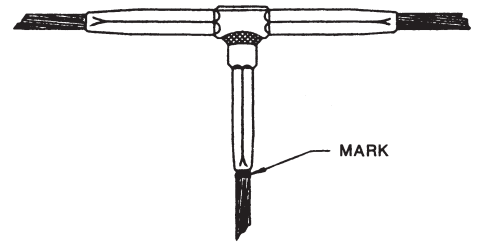

Index

4500 Series 107

4900 Series 108

5000 Series 34, 73, 110

5100 Series 40, 77, 101, 112

5200 Series 31, 71, 99

5300 Series 49, 85

5500 Series 46, 82

5600 Series 37, 75, 111

5800 Series 43, 80, 113

7000 Series 69

7500 Series 30, 98, 105

8500 Series 105

33000 Series 27

33100 Series 15, 53

33200 Series 103

33300 Series 18

33500 Series 57

33600 Series 60

33700 Series 89

43000 Series 55

43100 Series 91

43200 Series 63

43300 Series 66

43400 Series 94

43500 Series 96

43600 Series 21

43800 Series 24

Compression Joints

 AAC Conductors 69

 ACSR Conductors 27

 EHS ACSR Conductors 55

 AWAC Conductors 105

 Jiffy Joints – ACSR Conductors 30

 Jiffy Joints – AAAC and ACAR Conductors 98

 Alumoweld® and Steel Ground Wire 108

Dead Ends, Compression, Single Tongue

 ACSR Conductor 15

 EHS ACSR Conductor 53

 AAC Conductor 57

 AAAC and ACAR Conductor 89

 AWAC Conductor 103

 Alumoweld® and Steel Ground Wire 107

Dead Ends, Compression, Double Tongue

 ACSR Conductor 18

 AAC Conductor 60

 AAAC and ACAR Conductor 91

Adjustable Clevis

 Single Tongue

 ACSR Conductor 21

 AAC Conductor 63

 AAAC and ACAR Conductor 94

 Double Tongue

 ACSR Conductor 24

 AAC Conductor 66

 AAAC and ACAR Conductor 96

Installation Instructions

 Dead Ends

 ACSR and ACSS Conductors 127

 ACSR Adjustable Dead Ends 129

 AAC, AAAC, ACAR and AWAC Conductors 133

 EHS ACSR, Alumoweld® and Steel Ground Wire 134

 Terminal Connectors

 ACSR, AAC, AAAC, ACAR and AWAC Conductors 131

 Alumoweld® and Steel Ground Wire 136

 Compression Joints

 ACSR Conductors 137

 AAC, AAAC and ACAR Conductors 139

 AWAC, Alumoweld® and Steel Ground Wire 140

 EHS ACSR Conductor 141

 Repair Sleeves 142

 Jumper Connectors 135, 143

 Tee Taps, Open Run 144

 Tee Connectors, Open Run 144, 145

Jiffy Joints

 ACSR Conductors 30

 AAAC and ACAR Conductors 98

Jumper Connectors

 ACSR Conductors 34

 AAC Conductors 73

 Alumoweld® and Steel Ground Wire 110

Pad Dimensions 117

continued
→

Index (cont.)

Quick Reference Guides

ACSR Conductors	7
AAC Conductors	9
AAAC and ACAR Conductors	11
EHS ACSR, Steel Ground Wire, Alumoweld® and AWAC	13
Standard Catalog Numbering System	14

Reference Material

Conductor Information for ACSR Conductors	121
Conductor Information for AAC Conductors	123
Conductor Information for AAAC Conductors	125
Conductor Information for ACAR Conductors	126
NEMA Standard Pad Sizes	117
Recommended Tightening Torque for Bolts	118
Steel Dead End Dimensions	119

Repair Sleeves

ACSR Conductors	31
AAC Conductors	71
AAAC and ACAR Conductors	99

Tee Connectors, Open Run

ACSR Conductors	46
AAC Conductors	82

Tee Taps, Open Run

ACSR Conductors	49
AAC Conductors	85

Terminal Connectors

Straight

ACSR Conductors	37
AAC Conductors	75
Alumoweld® and Steel Ground Wire	111

15°

ACSR Conductors	40
AAC Conductors	77
AAAC and ACAR Conductors	101
Alumoweld® and Steel Ground Wire	112

90°

ACSR Conductors	43
AAC Conductors	80
Alumoweld® and Steel Ground Wire	113

