

THIS DRAWING AND ALL INFORMATION ON IT IS THE PROPERTY OF AFL. IT IS CONFIDENTIAL AND IT IS GIVEN TO YOU FOR A LIMITED PURPOSE AND MUST BE RETURNED UPON REQUEST. NEITHER THIS DRAWING OR ANY PART OF IT NOR ANY INFORMATION CONCERNING IT MAY BE COPIED, EXHIBITED, OR FURNISHED TO OTHERS NOR PHOTOGRAPHS TAKEN OF ANY ARTICLE FABRICATED OR ASSEMBLED FROM THE DRAWING WITHOUT THE CONSENT OF AFL.

ITEM NO:

DWG. NO:

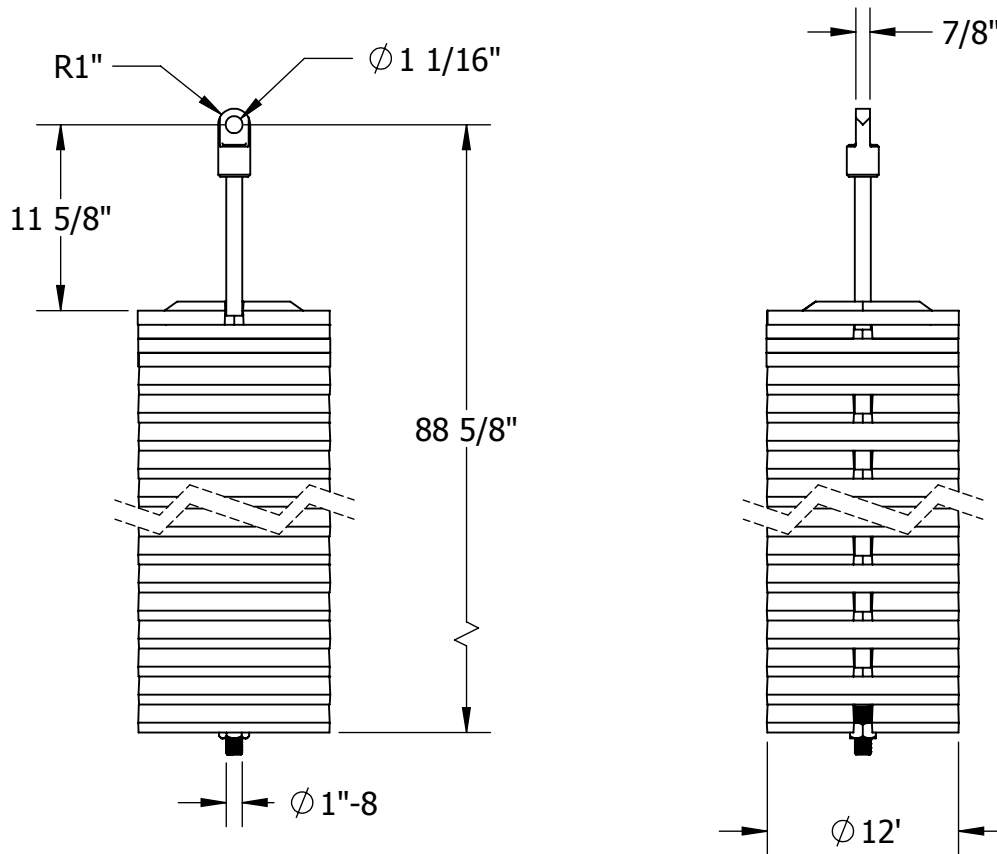

**MATERIAL:**

WEIGHT SUPPORT & PLATE - STEEL ASTM A29, H.D.G\*  
 HEX NUT - STEEL ASTM A325, H.D.G\*

STANDARD WEIGHT - GREY IRON, H.D.G\*  
 WGT: 47 LBS/EA

ADJUSTMENT WEIGHT - GREY IRON, H.D.G\*  
 WGT: 29.5 LBS/EA

**NOTE:**

WEIGHT STACK SHOWN IS APPROX 2500 LBS FOR BASE ESTIMATED  
 QTY (42) STANDARD WEIGHT + (4) ADJUSTMENT WEIGHT + SUPPORT.  
 (ADDITIONAL ADJUSTMENT WEIGHTS SHOWN NOT INCLUDED)

\* = HOT DIP GALVANIZED

REVISIONS					DRN BY:	CONTRACT NO		CUST / CONTR	
REV	DESCRIPTION	DATE	BY	APR	HV				
					DRN DATE:				
					07/30/2015				
					CHK BY:				
					JL				
					CHK DATE:				
					7.30.15				
					PA 2015.231.0	REV	PART NO:		
						0	BWS-IN-2500-01		



BWA, WEIGHT KIT, INTERNAL, 2500 LBS, 12" DIA