



INSTALLATION INSTRUCTIONS

AFL Apex® X-2S Sealed Splice Closure



TABLE OF CONTENTS

PACKAGE CONTENTS	2	CABLE GROUNDING	9
REQUIRED TOOLS	2	INSTALLING SEALING WEDGE.....	10
ADDITIONAL KITS.....	2	SMALL DIAMETER CABLE BUSHING	10
APEX DEFINED	3	ROUTING IN SPLICE BASKET	11
OPENING APEX.....	5	SPLICE TRAY OPTIONS AND ROUTING	12
SEALING WEDGE REMOVAL	6	INSTALLING SPLICE TRAY	13
CABLE PREPARATION	7	ALTERNATE SPLICING METHOD.....	14
LENGTH TABLE.....	7	FINAL ASSEMBLY	15
CABLE ATTACHMENT UNIT	8	MOUNTING APEX.....	16

PACKAGE CONTENTS

Apex Closure
 Cable Attachment Unit Kits - as ordered
 Splice Trays installed in Apex - as ordered

Installation Kit
 3/8" Velcro®
 Installation Instructions

REQUIRED TOOLS

216 can wrench
 Tape measure
 Tie wrap or Velcro for basket retention
 Wire cutter for strength member
 Splicer's scissors
 Splice equipment and sleeves
 Cable entry tools
 Cable stripper

Cable splicer knife
 9" Lineman's pliers

Optional Consumables

AFL Foam Retention Kit (pack of 25 - AFL no. HW000406)
 Mesh transition tube, if desired (AFL no. AX-KIT-TUBE-014-XX*)
 Silicone spiral wrap (AFL no. FC001657)

ADDITIONAL KITS

Ordering Information

DESCRIPTION	AFL NO.
Aerial strand mount hanger kit	AX-KIT-AERIAL-1
Pole/wall mount kit	AX-BR30
1/4" Colored Mesh Transition Tubing, 250' Spool	AX-KIT-TUBE-014-XX*
Single Cable Strain Relief/Cable Attachment Unit (CAU) Kit	AX-KIT-CBLSTRN
Multi-Drop Cable Entry Kit (fits up to 4 cables 0.20" to 0.39" in diameter or flat drop cable)	AX-KIT-DROP-4
X-2 and X-2S Dome to Base O-Ring Replacement Kit	AX-KIT-ORING-2
X-2 and X-2S O-Ring Grease, Pack of 10	AX-KIT-GREASE-10
X-2 and X-2S Dome to Base Locking Ring Clamp Replacement Kit	AX-KIT-CLAMP-2
X-2 and X-2S Wedge Replacement Kit	AX-KIT-WEDGE-2
X-2 and X-2S Installation Stand	FC104649
Apex X-2 and X-2S Inner Base Gel Replacement Kit	AX-KIT-GEL-2
Apex X-2S Dome Replacement Kit	AX-KIT-DOME-2S
WTC-SWR Bundle Splice Tray Retention Kit - Includes 25 foam grommets for retaining SWR bundles to splice trays	HW000406
Silicone Spiral Wrap, 5.5 Foot Length	FC001657
Velcro, 75 Foot Length Roll – For securing SWR bundles in the slack basket	FC001759
Apex Cable Bonding Kit (Bonds armored cable sheath to ground) – Pack of 10	AX-KIT-GROUND-10
Apex Advanced Fiber Retention System (AFRS) Kit 1 – Used for Ribbon Cable (Flat Matrix, SWR, Tubed, Central Core). Kit includes: Mesh Basket Adapter (2 ea.), Mesh Housing (2 ea.), Mesh Insert (24 ea.), V-Clips (12 ea.), and Clean Cut Gray Mesh (13 ft.).	AX-KIT-AFRSRBN
Apex AFRS Kit 2 – Used for Loose Tube Cable. Kit includes: V-Clip (24 ea.) and Retention Pads (6 sheets of 8 pads)	AX-KIT-AFRSLT
Apex AFRS Kit 3 – V-Clip bulk kit. Includes: V-Clips (120 ea.) and Mesh Inserts (120 ea.)	AX-KIT-AFRSVC-120
Apex AFRS Kit 4 – Mesh bulk kit. Includes: Clean Cut Gray Mesh (100 ft.)	AX-KIT-AFRSMESH-100FT
Apex AFRS Kit 5 – Mesh Housing bulk kit. Includes: Mesh Basket Adapter (10 ea.) and Mesh Housing (10 ea.)	AX-KIT-AFRSAH-10
Apex AFRS Kit 6 – Mesh Basket Adapter bulk kit. Includes: Mesh Basket Adapter (10 ea.)	AX-KIT-AFRSA-10

*Replace "XX" with any of the following for colors per the TIA-598 color code - BL, OR, GR, BR, SL, WH, RD, BK, YL, VI, RS or AQ

DESCRIPTION	TRAY CAPACITY		AFL NO.
	SINGLE	MASS	
X-2S Tray loaded with one splice module	18	72	AX-TRAY-2S-1
X-2S Tray fully loaded with two splice modules (288 fibers per tray only recommended for rollable ribbon, e.g. AFL SWR)	36	288	AX-TRAY-2S-2
Additional splice module (18 single fusion triple stacked, 12 mass fusion double stacked, 6 mechanical) – Pack of 20	-	-	AX-TRAY-MOD-20
X-2S Tray Empty	-	-	AX-TRAY-2S-E

*288 fibers per tray with mass fusion double-stacking (1,728 total closure capacity) only recommended for 200 um type rollable ribbon. For 250 µm, cut capacity in half with single-stacking

APEX DEFINED

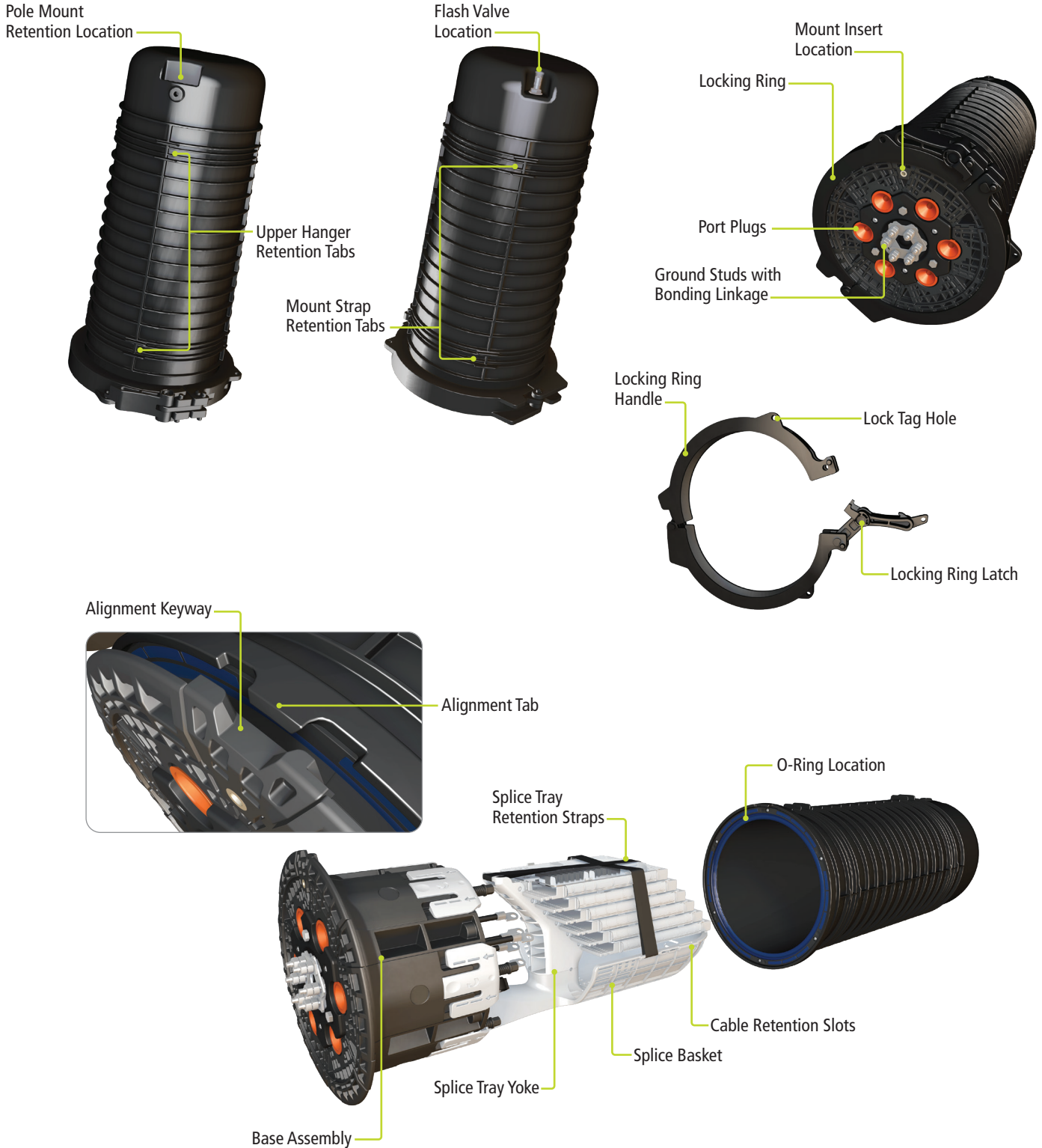

APEX DEFINED

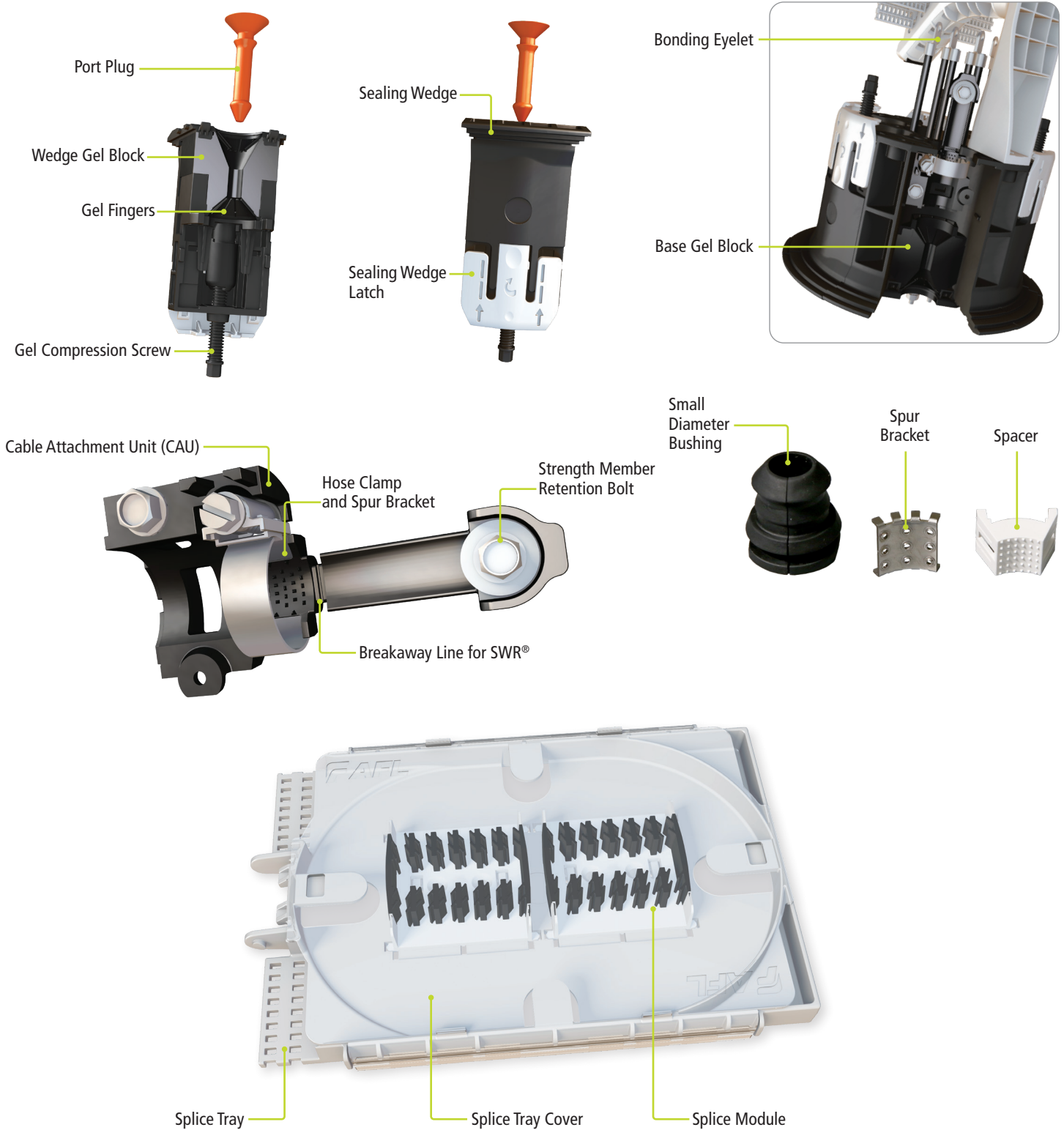

OPENING APEX

1. Release pressure valve to ensure no pressure or vacuum is present. (Figure 1)
2. Disengage locking ring.
3. Pull lock ring handle to disengage. (Figure 2)
4. Disengage lock ring latch.
5. Set aside Lock ring.
6. Orient Apex to have mount insert alignment tab up. (Figure 3)
7. Slide Apex dome off base and take care to keep attached dome O-ring seal area clean.
8. Install Apex into optional Installation Stand. (Figure 4)
9. Align mount insert alignment tab on top in center, basket down.
10. Set Apex on stand with base ring secured in stand slot.
11. Engage both retention clamps on base.
12. Undo both splice tray retention straps.
13. Remove splice trays.
14. Disengage splice tray using sheath knife or similar method to open the splice tray hinge. (Figures 5 and 6)
15. Rotate splice tray to disengage.
16. Loosen stand retention clamps to install backbone cable in port 1 and port 2. Rotate Apex to have basket on top, mount insert at bottom, and re-engage stand retention clamps.

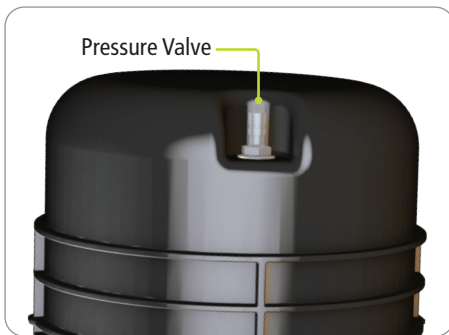

Figure 1



Figure 2

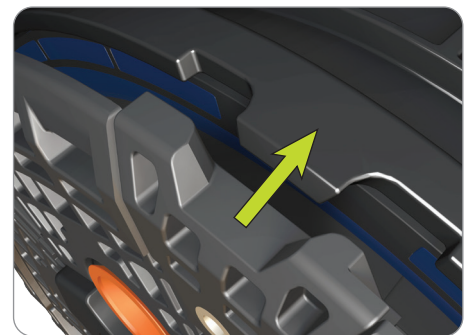

Figure 3

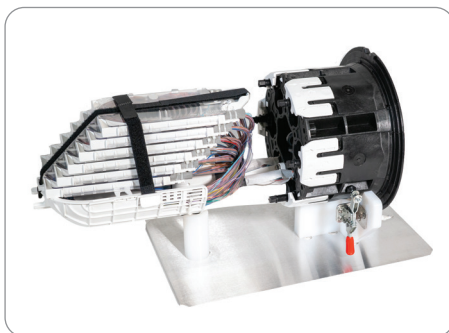

Figure 4



Figure 5

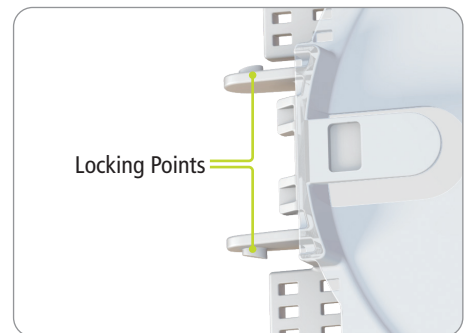

Figure 6

SEALING WEDGE REMOVAL

For the port to install a cable:

1. Depress sealing wedge latch and slide wedge cover toward the base. (Figure 7)
2. Rotate wedge away from base pivoting at the base of the wedge.
3. Rotate until the wedge tabs disengage from the base.
*** Tip: Hold tip of orange plug in base when opening wedge.**
4. Take orange port plug and discard after installation is complete. (Figure 8)
5. Ensure the base gel remains secure in the base.
*** If it becomes separated, simply re-install making sure the lower fingers engage properly in the base.**
6. Manually compress the base gel block. (Figure 9)
7. Confirm that sealing wedge gel compression screw is fully open.
8. Manually elongate wedge gel block. (Figure 10)
9. Set aside in a safe location.
*** If either gel block is contaminated with dirt or debris, simply rinse gel block with water.**



Figure 7

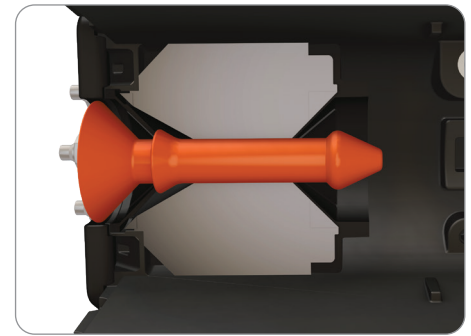

Figure 8



Figure 9



Figure 10

CABLE PREPARATION

Cable diameter, single port, in. (mm) 0.40" – 1.10" (10.0 – 28.0)

Cable diameter, multi-drop kit, in. (mm) 0.20" – 0.39" (5.0 – 9.9) or flat drop

LENGTH TABLE

CABLE /COMPONENT	TYPE OF OPENING	APEX X-2S (in.)
Prep Length		
Wrapping Tube Cable (WTC)/Non Matrix Ribbon	Mid sheath	80-98**
	End cut	40-66**
Flat Matrix Ribbon	Mid sheath	80-82*
	End cut	40-42*
*** Loose Tube fiber	Mid sheath	80-98**
	End cut	40-66**
All cable types	Sheath to tray	32
CSM or strength members (Non SWR®)		2 – 2 ¼
Storage		
Each additional basket storage loop		16-18
Each additional Splice tray service loop		17-18
Sheath to basket for tube retention		7-9
Definition		
Midsheath	Slack loop in basket, service loop in tray, center cut	
End cut	Slack loop in basket, service loop in tray, to far splice location	
Sheath to tray	Slack loop in basket	
* Ribbon minimum is slack loop in basket, no slack waterfall splicing in tray		
** Minimum. No service loop in splice tray – maximum allowing for service loop in splice tray		
*** LT storage max tubes	Additional tubes will decrease cable lengths	12(288/24 per tube)

AFL Wrapping Tube Cable (WTC)

- No need to secure strength rods.
- 8 - 11" of dielectric sheath or water block tape can be brought to basket.

Flat matrix ribbon

- Core tube or ribbon tube should extend from the sheath opening to be secured on the basket.
- Ribbon should be exposed from that point.

Loose tube

- Retained in basket. Leave loose tube stranding intact wherever possible in slack loop.

CABLE ATTACHMENT UNIT (CAU)

Parts of the CAU (Figure 11 and 12)

- Sheath end
- Hose clamp gear nest in CAU
- Strength member retention bolt
- Alignment tab on back
- SWR breakaway line
- Spur bracket and orientation small diameter cable bushing
- Small diameter cable (<0.55") Bushing and Spacer

Strength member (single or dual) trim to 2-2 ¼" as needed.

*** Cable must be clean and free of all tape, dirt or contamination for proper sheath retention and sealing.**

For WTC/SWR

1. Remove by hand, the strength member retention from the CAU at the breakaway line by hand. (Figure 11)
2. Armored WTC sheath will end at the CAU sheath end location.
 - Armor bond tab should be at 90 degrees to the CAU. (Figure 13)
3. Dielectric WTC or water block tape may be brought all the way to the basket.

For Flat Matrix and LT

1. Sheath should be installed even with (or beyond) the breakaway line.
2. Secure strength members under retention bolt without trapping or pinching tubes. (Figure 14)

Bushing Test for Small diameter cable (<0.55")

1. Test if Spacer and Bushing are needed by putting the cable bushing on the fully-jacketed cable. **** NOTE:** A spacer and bushing are not needed when using a multi cable drop kit.
 - a. If the seams touch, you will use both the Bushing and the Spacer (<0.55"). (Figures 14A and 14B)
 - b. If the seams do NOT touch, the Spacer and the Bushing are not needed. (Figure 14C)
2. If the seams of the bushing meet, you will need to install a Spacer as well. Simply snap the spacer on the CAU as shown in Figure 14. It is universal and may be installed in either direction. Ensure the spacer is secured and clipped on both sides of the CAU.
3. Continue with installation of Cable and utilize the small diameter cable bushing when directed.

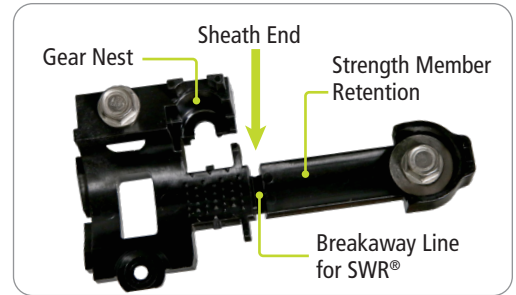

Figure 11

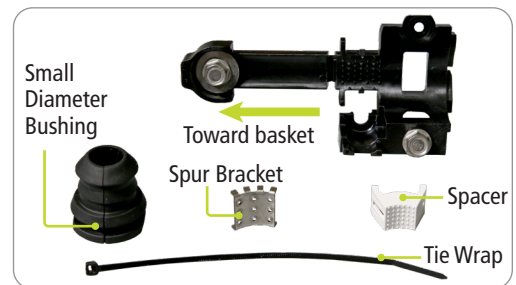

Figure 12

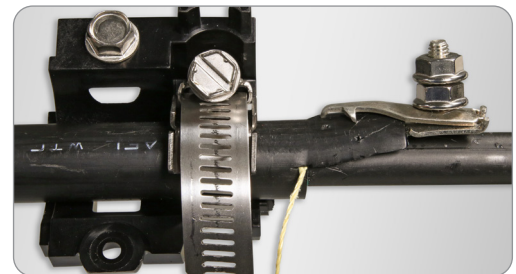

Figure 13

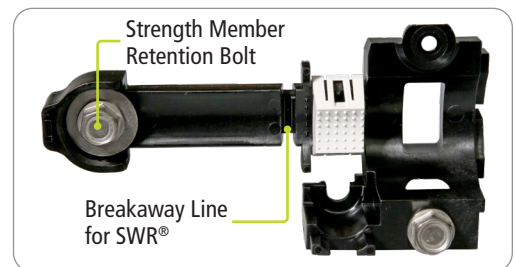

Figure 14



Figure 14A



Figure 14B



Figure 14C

Spur Bracket Orientation under Hose Clamp

1. The spur bracket **MUST** be installed completely under the hose clamp ring at the top of the cable. This will be the same with or without a spacer. (Figure 15A)

Figure 15B shows small diameter cable with the spacer installed, spur bracket at the top of the cable and the hose clamp.

- ⊗ *For WTC/SWR or other preferential bend cable, the strength rods should be parallel to the basket for all cables entering the closure. This aids with the natural direction and ease of coiling all cables.*

- ⊗ *For mid-sheath on all WTC / SWR binders and tubed flat matrix ribbon, ensure there is no twisting in the mid sheath opening that occurs to trap groups in the splice basket.*

For all Thin-Walled Jettable Micro Cable

1. Install hose clamp without the spur bracket on any jettable Micro Cable (Figure 15C).
 - Bushing and spacer may be needed if not using a multi drop kit. If cable is over 0.40", add spacer to CAU if Bushing test shows it is "Small Diameter Cable" (<0.55"). Install the cable(s) so the sheath extends just past the breakaway slot on CAU allowing the hose clamp to fully engage on the cable.
 - Trim and secure all cable strength members under the Central Strength Member (CSM) retention bolt and tighten.
 - Install hose clamp **WITHOUT** spur bracket on all jettable Micro Cable and nest worm gear in CAU.
 - Tighten hose clamp to secure cable but not to the point of crushing the cable or attenuating the fiber.
- ⊗ *If cable is less than 0.40" (0.20" - 0.39") a multidrop kit must be used. Blank inserts must be installed in all unused positions. Follow Apex multidrop instructions.*

For traditional cable types

1. Secure hose clamp and install spur bracket making sure it is properly oriented (spur bracket on top of cable), but **do not fully tighten**.
2. If cable is armored a tab will be left for the ground stud, it should be oriented to the side of the CAU. (Figure 16)
3. Tighten hose clamp to tighten to 30 in-lb which is about the maximum you can get on a can wrench.

- ⊗ *Cable must be clean and free of all tape, dirt or contamination for proper sheath retention and sealing.*

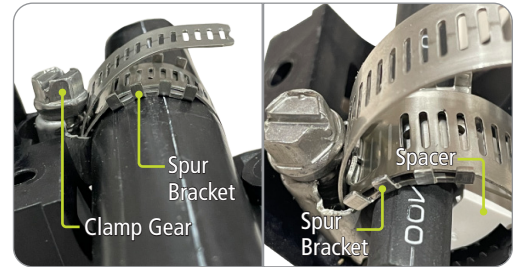

Figure 15A

Figure 15B

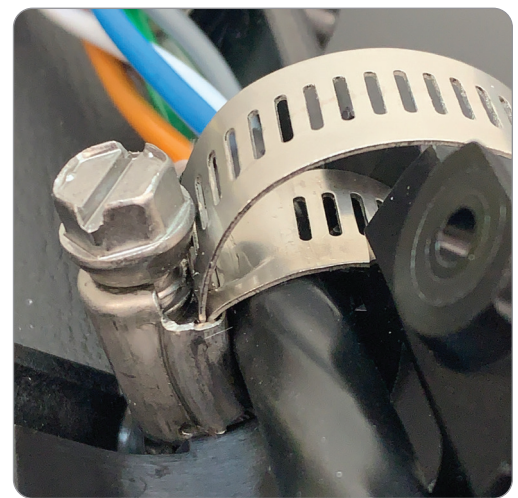

Figure 15C

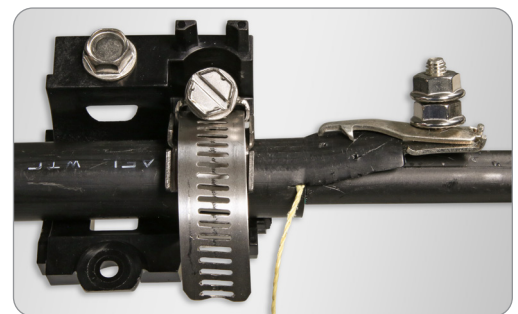

Figure 16

CABLE GROUNDING

- Armored cables can be bonded using Apex ground clips. Simply slit cable armor on both sides at approximately 1" and install bonding hardware. (Figure 17)
- Bonding hardware is typically defined by local practice or end user. Apex offers a bonding eyelet for up to a ¼" ground stud. (Figure 18)

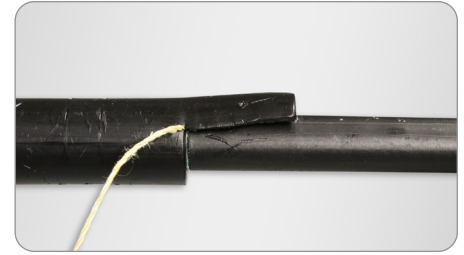

Figure 17

Installing the populated CAU into Apex base

1. Bring CAU and Cable to base and carefully guide the exposed fiber to the basket.
2. Lower CAU to base and engage alignment tab. (Figure 19)
3. Using 216 can wrench, begin to thread the CAU retention screw.
 - Confirm alignment of CAU and fiber cable orientation.
 - Confirm the tail of hose clamp is in position to be retained.
 - Fully tighten CAU retention bolt. (Figure 20)
4. If applicable, verify WTC cable rods are aligned in the same orientation parallel to the basket. This goes for all ports on Apex.
5. Tighten the hose clamp to 30 in-lb. to secure cable.

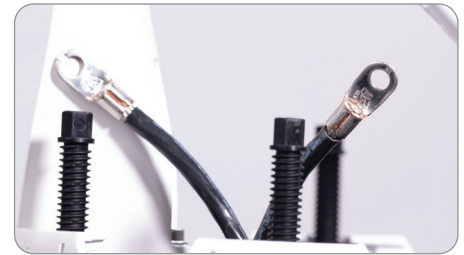

Figure 18

⊛ *Do not over tighten hose clamp. It may affect the optical characteristics of the cable.*

6. Secure inbound fibers or tubes with Velcro or tie wraps near yoke of basket and outbound fibers should be secured closer to the outside of the basket. (Figure 21)



Figure 19

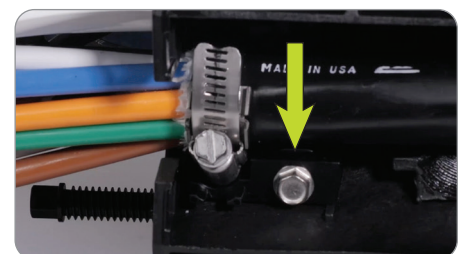

Figure 20



Figure 21

INSTALLING SEALING WEDGE

Make sure cable and ground are properly oriented and will not interfere with sealing wedge installation.

1. Depress base gel and elongate sealing wedge gel. (Figures 8 and 9 — page 6)
2. Ensure gel compression screw is in the relaxed position.
3. Engage sealing wedge pins into bottom of base. (Figure 22)
4. Rotate sealing wedge into place and depress the sealing wedge lock tab to engage latch and fully lock into place.
5. Inspect top and bottom of sealing wedge for complete engagement.
6. Attach bonding eyelet if applicable. (Figure 23)

SMALL DIAMETER CABLE BUSHING

1. Open bushing and install over small diameter cable with the taper toward the base. (Figure 24)
2. Take supplied tie wrap, begin to secure it within the groove.
3. Align head of tie wrap in opening of bushing slot. (Figure 25)
4. Pull tie wrap to cinch. Do not over tighten to deform bushing.
5. Slide bushing toward base port and firmly insert into wedge gel. (Figure 26)

⊛ *This bushing MUST be installed prior to compression of the gel compression screw.*

6. Tighten gel compression screw with 216 can wrench or similar tool. This will tighten to a positive stop; no need to tighten past that stop. (Figure 27)
7. Rotate closure in stand to install additional cables. Repeat CAU installation process.

⊛ *Once all cables have been installed and the gel compression screws have been tightened, the remaining empty port gel compression screws must be tightened on the orange port plug to seal the closure.*

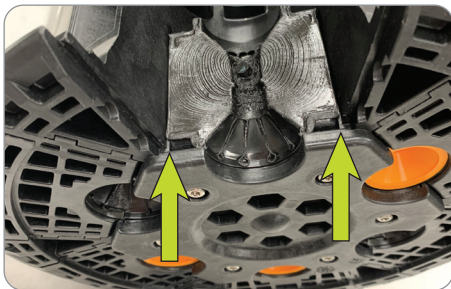

Figure 22

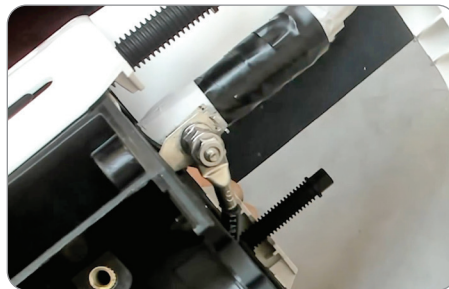

Figure 23

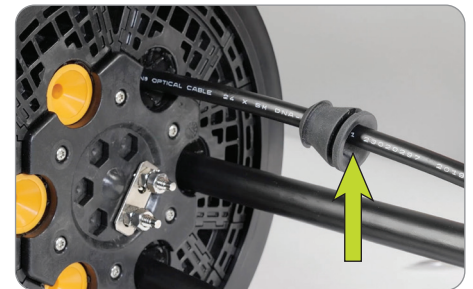

Figure 24

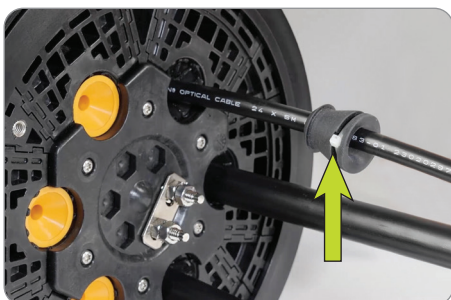

Figure 25



Figure 26



Figure 27

ROUTING IN SPLICE BASKET

All length cables include a storage loop in the basket. (Figure 28)

1. Rotate closure in stand to basket down position for the fiber to be routed and spliced.
2. Basket tabs may be removed for ease of initial installation squeezing and rotating the basket tab to remove.
3. These tabs may be replaced in the basket after initial installation.
4. Input cables are installed near the yoke base and exit near the top edge of basket.
5. Secure units with Velcro or tie wraps. (Figure 29)
6. Transport ribbon fiber from basket to tray with or without additional protection. AFL silicone spiral wrap, transition tubes or nylon weave may be used if desired.
7. Do not completely tighten the retention on fibers exiting to the tray. Basket fiber slack may need to be adjusted before final dressing.

⊗ *SWR and ribbon fiber can be safely transported from the basket to the tray without any additional protection. Secured with AFL foam retention. (Figure 30)*

8. Additional storage loops can be retained in the basket – see length table, page 7.
9. Ribbon fiber should be retained toward the center of the basket if branch or drop cables will be installed.
10. Branch or drop cables should be routed to the upper edge of the basket.

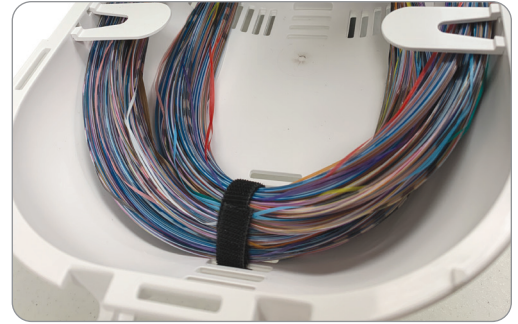

Figure 28



Figure 29



Figure 30

SPLICE TRAY OPTIONS AND ROUTING

Apex splice trays are universal for Loose tube, Ribbon and SWR® splicing applications. Each Apex X-2S can hold up to 6 splice trays. Each Apex X-2S splice tray holds up to 2 modules.

FIBER	SLEEVES PER MODULE	X-2S SPLICE TRAY 2 MODULES
Single loose tube	18 splices triple stacked	36 fibers
Flat matrix ribbon	12 double stacked	144 fibers
SWR/Non-matrix ribbon	12 double stacked	288 fibers

Splice trays can be shipped empty, partially loaded or fully loaded and splice modules are field movable. (Figure 31)

1. To add a splice module to Apex splice tray, simply align the latch tabs. (Figure 32)
2. Slide to engage. (Figure 33)
3. To remove a splice module simply disengage the locking tabs on the back with a pair of shears and slide module to release latch. (Figure 34)
4. SWR and Loose Tube fiber is spliced using slack storage in the tray. (Figure 35)
5. Flat matrix ribbon is typically waterfall spliced; but there is room for storage if desired. (Figure 36)

⊗ *The openings between modules are designed to act as a fiber pathway if desired.*

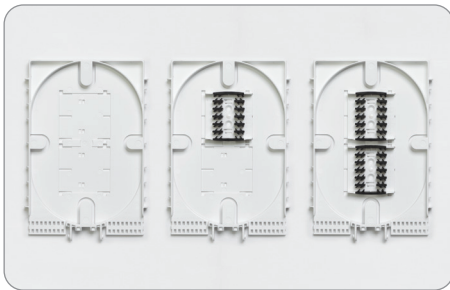

Figure 31

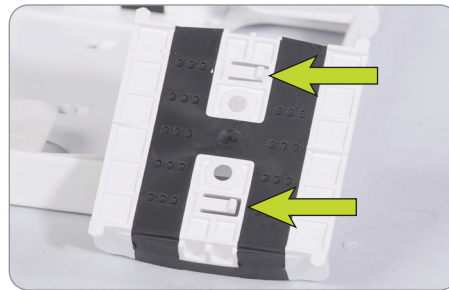

Figure 32

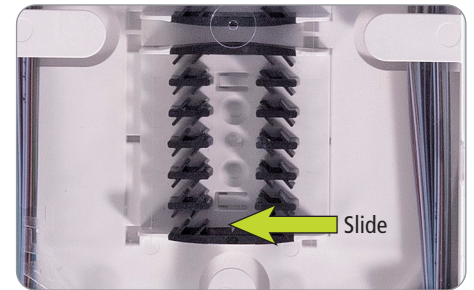

Figure 33



Figure 34

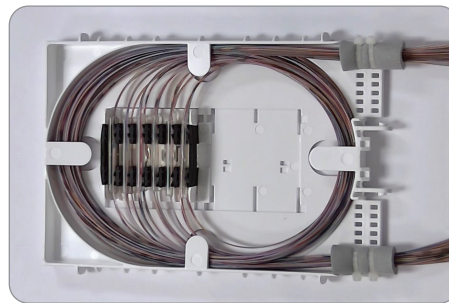

Figure 35

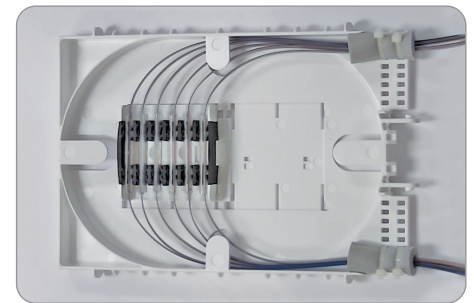

Figure 36

INSTALLING SPLICE TRAY

All types of splicing, loose tube or ribbon, can be done in the same splice tray and can coexist in the same tray if desired.

1. Splice trays should be installed from the bottom up without a gap.
2. Tubes should be attached to tray one layer at a time, bottom up to prevent trapping.
3. Install splice tray by engaging hinge pin onto yoke and rotating tray into place. (Figure 37)
4. Raise the tray to its upper locked position.
5. Release tray by depressing locking tab at the bottom center of the tray and lower into place. (Figure 38)
6. Loosely secure fiber or tubes at tray entrance.
 - Use a few wraps of electrical tape, or similar, on loose tube products. (Figure 39)
 - Two tie wraps per bundle – supplied. (Figure 39)
 - Secure with AFL foam retention. (Figure 40)
 - Optional transition tube. (Figure 41)
7. Begin routing to splice.
 - Each bundle of fibers will make a full loop in the tray to splice to the furthest location.
8. Once all splices are complete, address the slack behind the yoke in both open and closed positions. Adjust slack and secure both the tray and basket retention on the fibers.



Figure 37



Figure 38

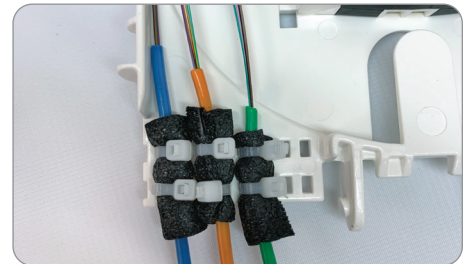

Figure 39

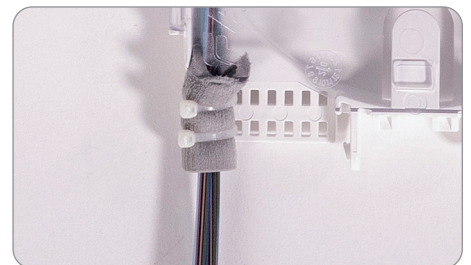

Figure 40

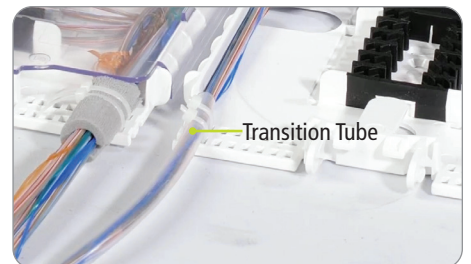

Figure 41

ALTERNATE SPLICING METHOD

Apex is designed for high-count fiber splicing. The following is a method where multiple splicers can work simultaneously on one case.

1. On the length table (page 7), use the "Sheath to Tray" distance.
2. Take fibers straight from CAU over the basket and mark fibers or tube at this distance.
 - Protect the fibers as they lay over the basket edge.
3. Secure fibers or tubes to tray at mark. **(Figure 42)**
4. Splice, route and close tray.
5. Figure-8 the fiber into the tray at the top of the basket and again under the yoke. **(Figure 43)**
6. Install trays starting from the bottom up without skipping a slot.
7. Once all splices are complete, address the slack behind the yoke in both open and closed positions. Adjust slack and secure both the tray and basket retention on the fibers.

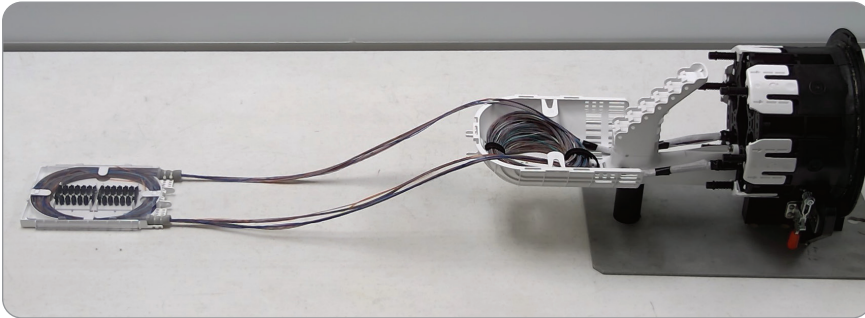

Figure 42

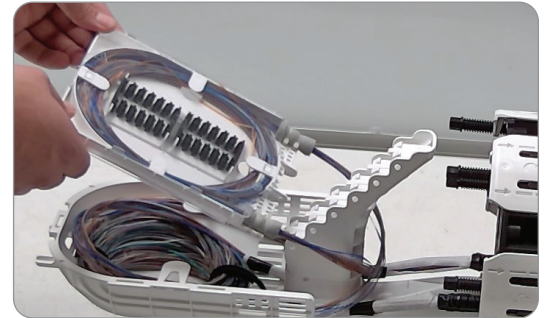

Figure 43

FINAL ASSEMBLY

1. Ensure all cables, tubes and fibers are secured on both tray and basket.
2. Ensure orange blank plugs are installed in every unused port.
3. Ensure small diameter bushings are fully seated on cables under ½".

⊛ *The gel compression screw must be in the open position to install the orange blank plug or the small diameter bushing.*

4. Ensure all gel compression screws are fully engaged.
5. Pull the two Velcro straps through the horizontal and vertical strap slots soft side up. (Figure 44)
6. Secure the horizontal strap. (Figure 45)
7. Secure the vertical strap. (Figure 45)
8. Apply a thin coat of supplied grease on the top and inside of the O-ring to prevent sticking when installing Apex into dome. (Figure 46)

⊛ *For MSDS of the grease, visit our Environment, Health and Safety section at www.AFLglobal.com.*

9. Align the tab and slip dome on.
10. Engage lock ring latch and secure lock ring.
11. Note orientation of lock ring so the handle or hinge will not interfere with mount insert if pole/wall mounting. (Figure 47)
12. Secure lock ring handle to lock ring.
13. Apply lock tag if desired.

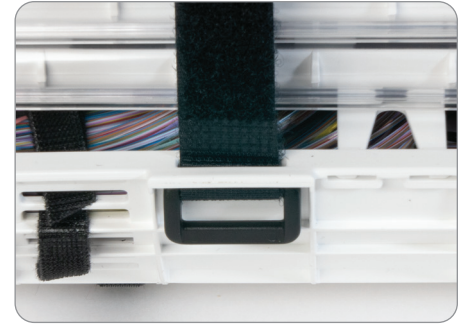

Figure 44

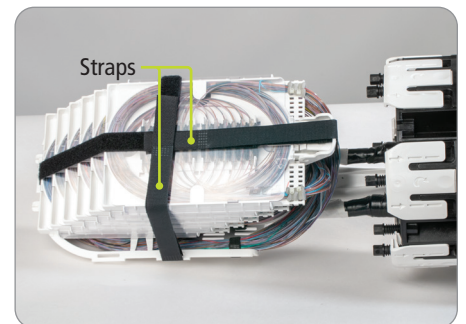

Figure 45



Figure 46

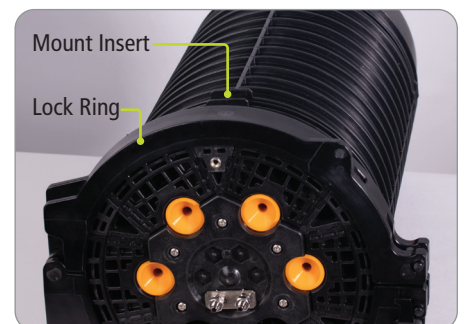

Figure 47

Flash test closure

1. Apply 5 PSI of air to the flash valve on dome. (Figure 48)
2. Inspect base for leaks with a spray of soapy water.
3. If there are no apparent bubbles, the closure passes.
4. If bubbling occurs:
 - Remove dome
 - Check sealing wedges
 - Check CAU brackets and hose clamps
 - Check the O-ring is clean and greased

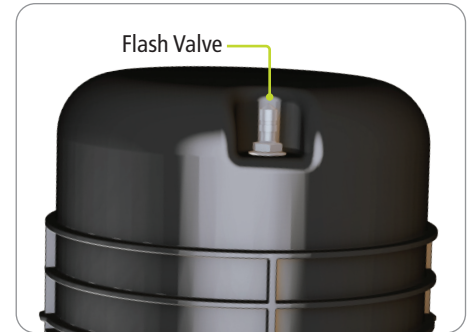

Figure 48

MOUNTING APEX

The Apex closure can be mounted to the strand using cable spacers and straps.

1. Align stack of cable spacers on the same side as the mount insert. (Figure 49)
2. Align strap with retention tabs on bottom of dome.
3. Secure straps and Apex to strand.



Figure 49

