

THIS DRAWING AND ALL INFORMATION ON IT IS THE PROPERTY OF AFL. IT IS CONFIDENTIAL AND IT IS GIVEN TO YOU FOR A LIMITED PURPOSE AND MUST BE RETURNED UPON REQUEST. NEITHER THIS DRAWING OR ANY PART OF IT NOR ANY INFORMATION CONCERNING IT MAY BE COPIED, EXHIBITED, OR FURNISHED TO OTHERS NOR PHOTOGRAPHS TAKEN OF ANY ARTICLE FABRICATED OR ASSEMBLED FROM THE DRAWING WITHOUT THE CONSENT OF AFL.

ITEM NO:

DWG. NO:

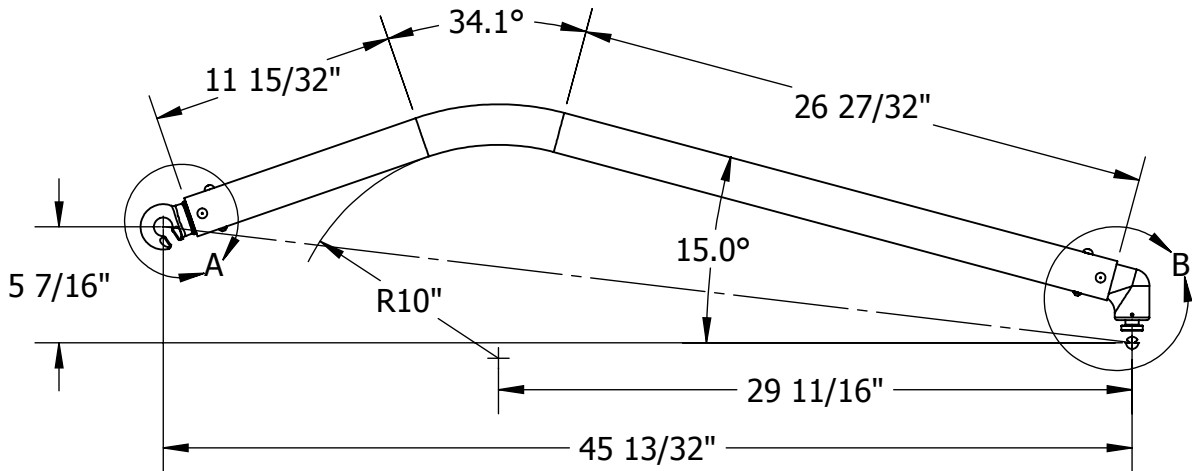
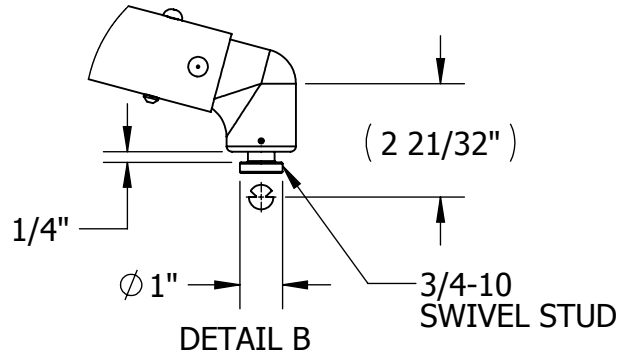
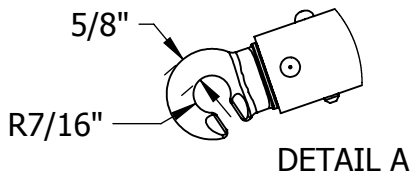

**MATERIAL:**

ALUMINUM ALLOY 1-1/2" IPS SCH 80, ASTM B221

SR END FITTING - ALUMINUM ALLOY ASTM B26

STEADY ARM FITTING - ALUMINUM BRONZE ASTM B30, TIN-PLATED

PINS - STAINLESS STEEL

WT: 6.25 LBS

LOCATION	CONTRACT NO	CUST / CONTR
----------	-------------	--------------

REVISIONS				
REV	DESCRIPTION	DATE	BY	APR

DRN BY:  
RK  
DRN DATE:  
7.9.15  
CHK BY:  
JL  
CHK DATE:  
7.9.15  
PA 2015.231.0

<p>STEADY ARM, 1-1/2" IPS, 3.78 FT, 1 BEND, SCH 80, AL</p>	
REV 0	PART NO: CSA150E-SR-1B-15-02
1 OF 1	