

THIS DRAWING AND ALL INFORMATION ON IT IS THE PROPERTY OF AFL. IT IS CONFIDENTIAL AND IT IS GIVEN TO YOU FOR A LIMITED PURPOSE AND MUST BE RETURNED UPON REQUEST. NEITHER THIS DRAWING OR ANY PART OF IT NOR ANY INFORMATION CONCERNING IT MAY BE COPIED, EXHIBITED, OR FURNISHED TO OTHERS NOR PHOTOGRAPHS TAKEN OF ANY ARTICLE FABRICATED OR ASSEMBLED FROM THE DRAWING WITHOUT THE CONSENT OF AFL.

ITEM NO:

DWG. NO:

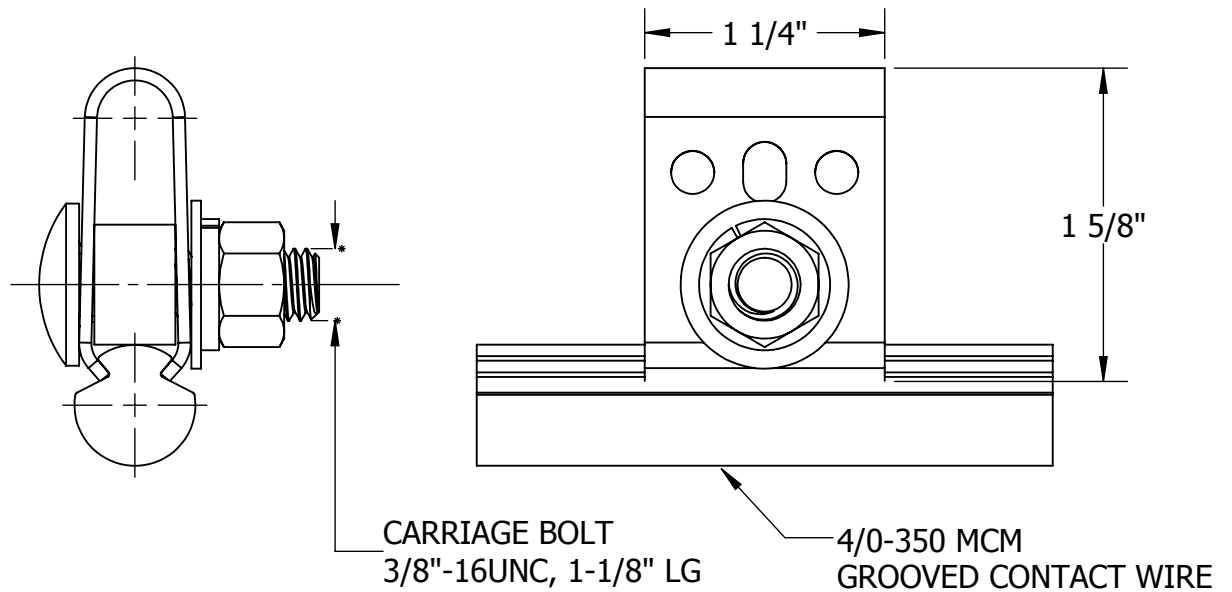

MATERIAL:

CLIP - SPRING BRONZE

BOLT, NUT , FLAT WASHER & LOCKWASHER - SILICON BRONZE

NOTE:

1. CAN BE USED ON SOLID ROD HANGERS, SINGLE ROD, LOOP ROD OR WIRE (WITH OPTIONAL BAIL CONNECTOR).

WT: 0.07 LB

LOCATION					CONTRACT NO		CUST / CONTR																															
<p>REVISIONS</p> <table border="1"> <thead> <tr> <th>REV</th> <th>DESCRIPTION</th> <th>DATE</th> <th>BY</th> <th>APR</th> </tr> </thead> <tbody> <tr><td> </td><td> </td><td> </td><td> </td><td> </td></tr> <tr><td> </td><td> </td><td> </td><td> </td><td> </td></tr> <tr><td> </td><td> </td><td> </td><td> </td><td> </td></tr> <tr><td> </td><td> </td><td> </td><td> </td><td> </td></tr> <tr><td> </td><td> </td><td> </td><td> </td><td> </td></tr> </tbody> </table>					REV	DESCRIPTION	DATE	BY	APR																										<p>DRN BY: BR</p> <p>DRN DATE: 7.31.17</p> <p>CHK BY: GC</p> <p>CHK DATE: 7.31.17</p> <p>PA 2015.231.0</p>		<p>F AFL DOSSERT®</p> <p>HANGER, CLAMP, CONTACT WIRE, 4/0 - 350MCM, SPRING CLIP, BNLW</p>	
REV	DESCRIPTION	DATE	BY	APR																																		
REV 0					PART NO:		SGC-34T																															
								1 OF 1																														