

Reference Grade Test Lead Kits

AFL's Reference Grade Test Lead Kits (TLK) provide an industry leading solution to optical link testing. Complying with Australian and New Zealand standards, AFL test leads and test lead kits have been made to suit the most common fibre optic link configurations for Singlemode and Multi-mode fibre installations.

Available in both simplex and duplex, AFL test leads are ready to perform uni or bi-directional testing with any light source, power meter or loss test set, regardless of the instrument's port configuration.



Features

- Connector geometry interferometry reports provided for every test lead
- Kits to suit one test cord reference method for common connector types and test equipment
- Customised test lead kits available upon request
- Available in simplex and duplex options
- Re-termination of encircled flux reference grade test leads with reference grade connectors by AFL
- For MM, EF Modal Controller is not required when using EF compliant AFL test equipment in conjunction with AFL Reference Grade Test Leads.

Applications

- LS/PM optical link testing
- Uni-directional optical link testing
- Bi-directional optical link testing

ISO 11801.1:2019 and AS/NZS ISO/IEC 14763.3:2017 Simplex Uni-directional

Light Source and Power Meter Referencing

- Select the one test cord referencing method where available and connect the lead as shown below
- For MM, launch lead connector output must be EF compliant
- Once the reference is set, DO NOT unplug the source connector
- For MM, reference the meter at both 850 nm and 1300 nm
- For SM, reference the meter at both 1310 nm and 1550 nm

Simplex Uni-directional One Test Cord Referencing Method

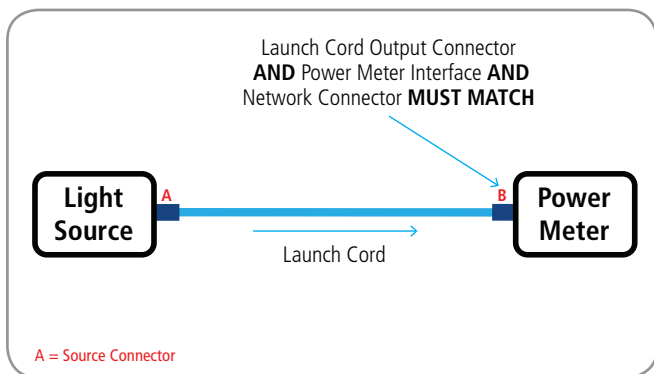

Optical Insertion Loss (Optical Link) Testing

- Remove the launch cord from the power meter. Add the tail cord to the power meter and connect to the link under test using the through adapters mounted in the coupler panels.
- For MM, conduct the link test at 850 nm and 1300 nm and then perform the testing in the opposite direction
- For SM, conduct the link test at 1310 nm and 1550 nm and then perform the testing in the opposite direction

Simplex Uni-directional One Test Cord Attenuation Measurement of Installed Link

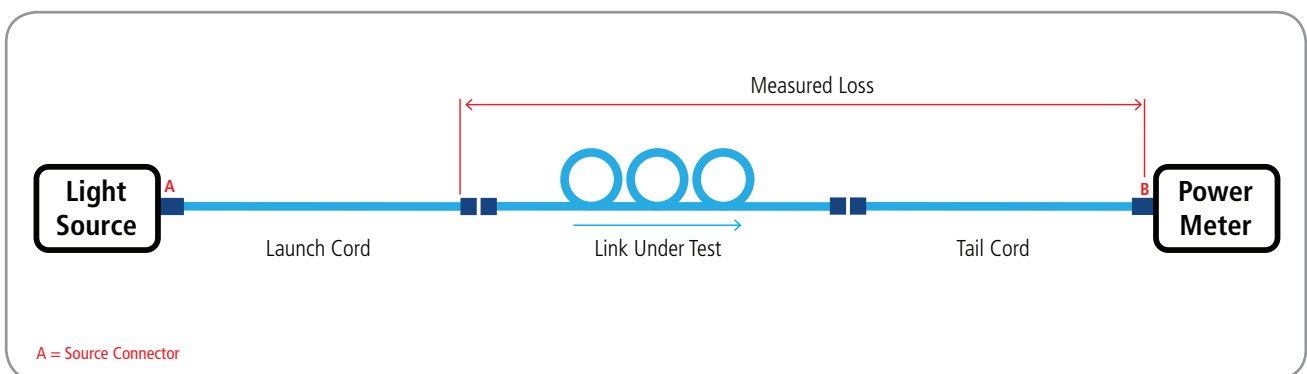

ISO 11801.1:2019 and AS/NZS ISO/IEC 14763.3:2017 Duplex Bi-directional

Loss Test Set Referencing

- Select the one test cord referencing method where available and connect the leads as shown below
- For MM, launch Lead connector outputs must be EF compliant
- Once the reference is set, DO NOT unplug the source connectors
- For MM, reference both testers at both 850 nm and 1300 nm
- For SM, reference both testers at both 1310 nm and 1550 nm

Duplex Bi-directional One Test Cord Referencing Method

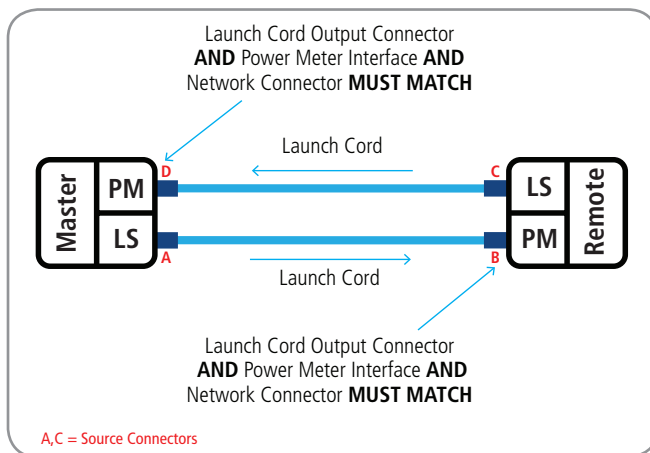

Optical Insertion Loss (Optical Link) Testing

- Remove the launch cord from the power meter. Add the tail cord to the power meter and connect to the link under test using the through adapters mounted in the coupler panels.
- For MM, conduct the link test at 850 nm and 1300 nm and then perform the testing in the opposite direction
- For SM, conduct the link test at 1310 nm and 1550 nm and then perform the testing in the opposite direction

Duplex Bi-directional One Test Cord Attenuation Measurement of Installed Link

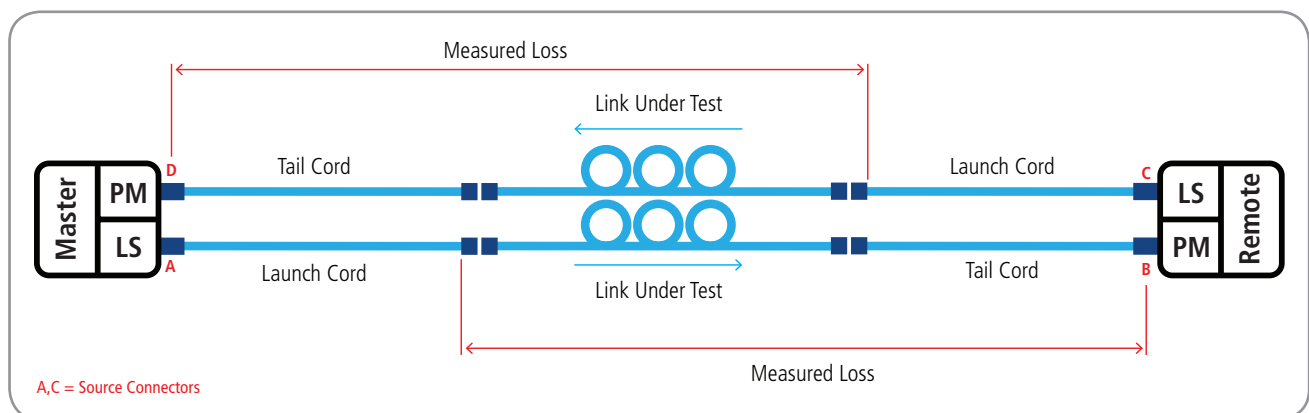

ISO 11801.1:2019 and AS/NZS ISO/IEC 14763.3:2017 Simplex Bi-directional

Loss Test Set Referencing

- Consult the user manual for this operation
- Select the one test cord referencing method where available and connect the leads as shown below
- For MM, launch Lead connector outputs must be EF compliant
- Once the reference is set, DO NOT unplug the source connectors
- For MM, reference both testers at both 850 nm and 1300 nm
- For SM, reference both testers at both 1310 nm and 1550 nm

Simplex Bi-directional One Test Cord Referencing Method

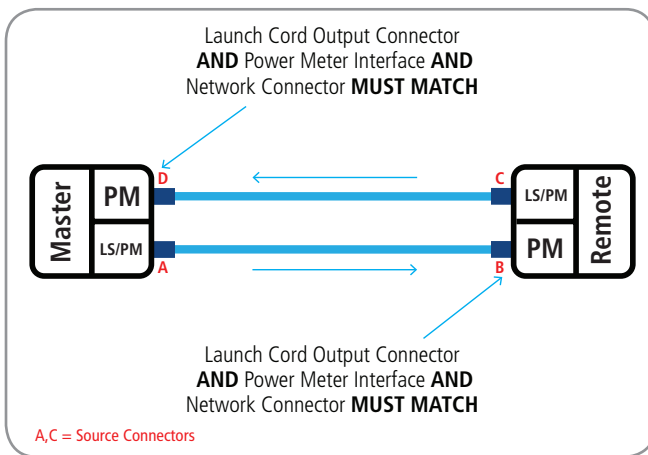

Optical Insertion Loss (Optical Link) Testing

Consult the user manual for this operation

Remove both launch leads from the power meter ports and connect them to the link under test using the through adapters mounted in the coupler panels

For MM, conduct the link test at 850 nm and 1300 nm

For SM, conduct the link test at 1310 nm and 1550 nm

Simplex Bi-directional One Test Cord Attenuation Measurement of Installed Link

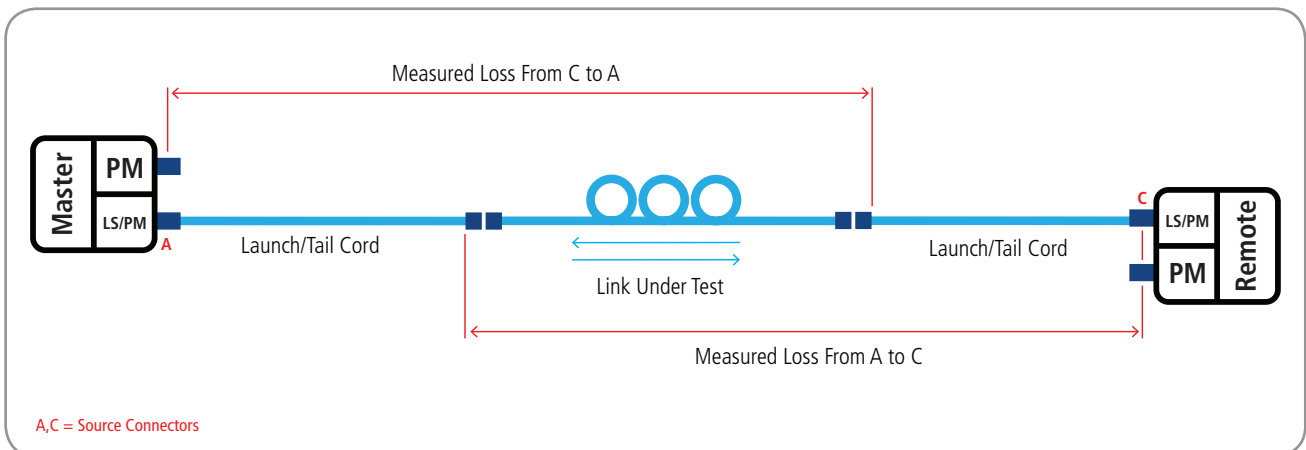

Ordering Information

PART NUMBER	DESCRIPTION
TLK-D3-EF-SC	Test Lead Kit, Duplex OM3/4 Encircled Flux for SC testing 2 x 50 µm OM3/4 Simplex Encircled Flux TLL Launch Test Leads 2 x 50 µm OM3/4 Simplex TLT Tail Test Leads Launch 2M SC/SC with EF Modal Controller, Tail 2M SC/SC
TLK-D3-EF-LC	Test Lead Kit, Duplex OM3/4 Encircled Flux for LC testing 2 x 50 µm OM3/4 Simplex Encircled Flux TLL Launch Test Leads 2 x 50 µm OM3/4 Simplex TLT Tail Test Leads Launch 2M SC/LC with EF Modal Controller, Tail 2M LC/LC
TLK-D1-SC	Test Lead Kit, Duplex Singlemode for SC testing 2 x OS1/2 Duplex TLLT Launch/Tail Test Leads Launch 2M SC/SC, Tail 2M SC/SC
TLK-D1-LC	Test Lead Kit, Duplex Singlemode for LC testing 2 x OS1/2 Duplex TLLT Launch/Tail Test Leads Launch 2M SC/LC, Tail 2M LC/LC
TLK-D1-SCA	Test Lead Kit, Duplex Singlemode for SCA testing 2 x OS1/2 Duplex TLLT Launch/Tail Test Leads Launch 2M SC/SCA, Tail 2M SCA/SCA
TLK-S1-SC	Test Lead Kit, Simplex Singlemode for SC testing 1 x OS1/2 Simplex TLL Launch Test Lead 1 x OS1/2 Simplex TLT Tail Test Lead Launch 2M SC/SC, Tail 2M SC/SC
TLK-S1-LC	Test Lead Kit, Simplex Singlemode for LC testing 1 x OS1/2 Simplex TLL Launch Test Lead 1 x OS1/2 Simplex TLT Tail Test Lead Launch 2M SC/LC Tail 2M LC/LC
TLK-S1-SCA	Test Lead Kit, Simplex Singlemode for SCA testing 1 x OS1/2 Simplex TLL Launch Test Lead 1 x OS1/2 Simplex TLT Tail Test Lead Launch 2M SC/SCA, Tail 2M SCA/SCA
TLK-D6-EF-SC	Test Lead Kit, Duplex OM1 Encircled Flux for SC Testing 2 x 62.5 µm OM1 Simplex Encircled Flux TLL Launch Test Leads 2 x 62.5 µm OM1 Simplex TLT Tail Test Leads Launch 2M SC/SC with EF Modal Controller, Tail 2M SC/SC
TLK-D6-EF-LC	Test Lead Kit, Duplex OM1 Encircled Flux for LC Testing 2 x 62.5 µm OM1 Simplex Encircled Flux TLL Launch Test Leads 2 x 62.5 µm OM1 Simplex TLT Tail Test Leads Launch 2M SC/LC with EF Modal Controller, Tail 2M LC/LC

- TLKs come with application notes and lint free wipes (x 8).
- TLL, TLT, TLC and TLLT lengths specified by AFL (recommended). For custom lengths, leads must be between 2 m - 5 m to comply with AZ/NZS ISO/IEC 14763.3:2017.
- Check with test equipment manufacturer for any special test cord length requirements.
- For custom test leads and replacements, contact your local AFL office for assistance
- AFL Single-mode Launch Test Leads do not contain air-coiled turns. They are to be used with Test Instruments provided with air-coiled turns as specified in the ISO/IEC 14763-3:2017 standard.
- All AFL Light Sources are built with air-coiled turns as per the standard afore mentioned.

Qualifications

ISO/IEC	14763.3:2017
ISO	11801.1:2019

Recommended Products

- AFL Inspection and Cleaning Products
- AFL Test Equipment