

ITEM NO

DWG NO
B-7962

THIS DRAWING AND ALL INFORMATION ON IT IS THE PROPERTY OF AFL. IT IS CONFIDENTIAL AND IT IS GIVEN TO YOU FOR A LIMITED PURPOSE AND MUST BE RETURNED UPON REQUEST. NEITHER THIS DRAWING OR ANY PART OF IT NOR ANY INFORMATION CONCERNING IT MAY BE COPIED, EXHIBITED, OR FURNISHED TO OTHERS NOR PHOTOGRAPHS TAKEN OF ANY ARTICLE FABRICATED OR ASSEMBLED FROM THE DRAWING WITHOUT THE CONSENT OF AFL.

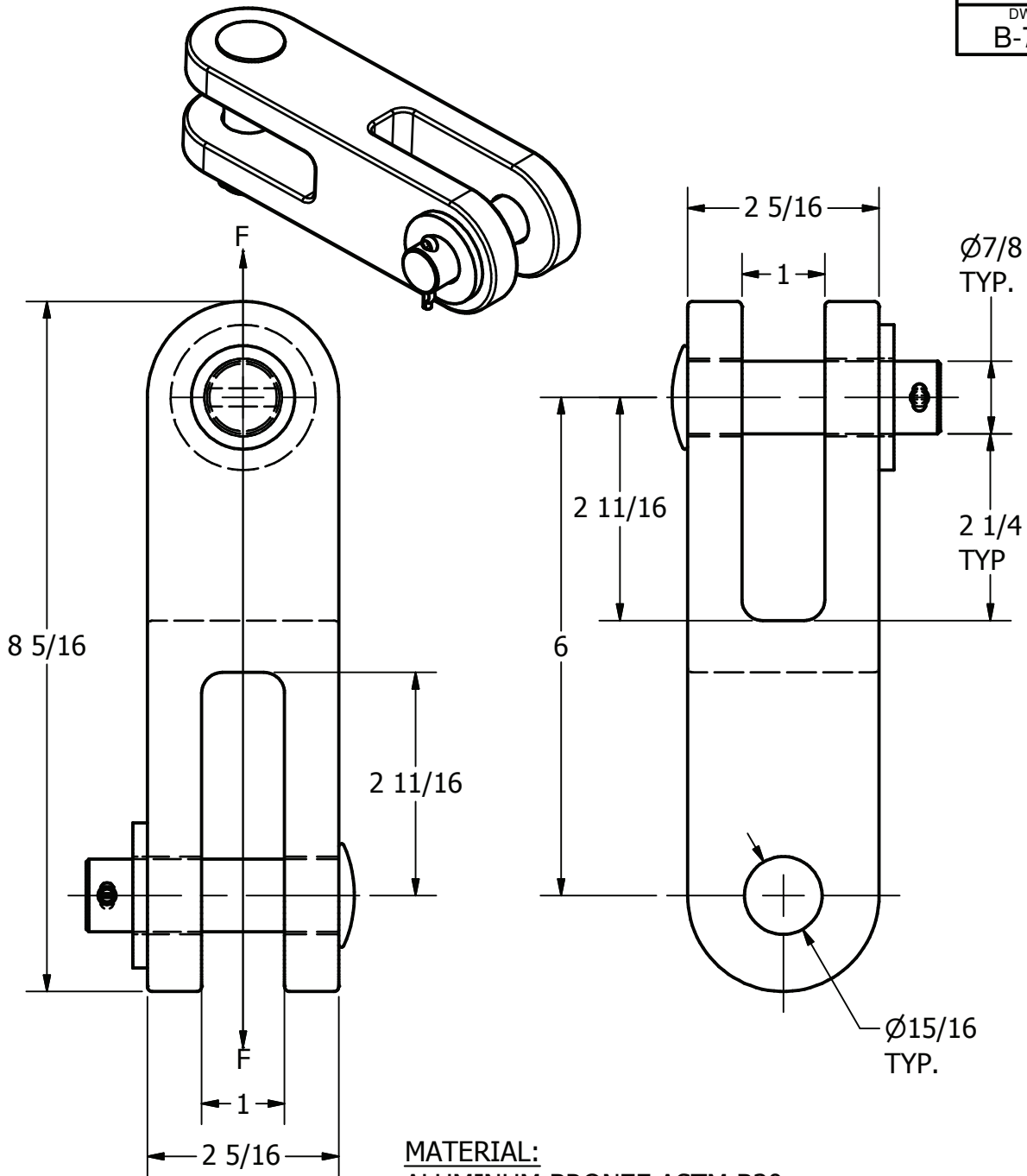

MATERIAL:
ALUMINUM BRONZE ASTM B30
CLEVIS PIN-GALVANIZED STEEL
COTTER KEY-STAINLESS STEEL

MIN ULTIMATE STRENGTH LOAD
"F" = 50,000 LBS

8.79 LBS

LOCATION				CONTRACT NO		CUST / CONTR	
REVISIONS				DRN BY: BB			
REV	DESCRIPTION	DATE	BY	APR	DRN DATE: 3-7-95		
6	RE-DRAWN IN INVENTOR	1-28-10	LK	EP	CHK BY: BB		
					CHK DATE: 3-7-95		
				REV	6		DCLA88-90-S
						1 OF 1	



LINK, DOUBLE CLEVIS 90°