

## Tee Connector—5500 Series for ACSR Conductors, Open Run

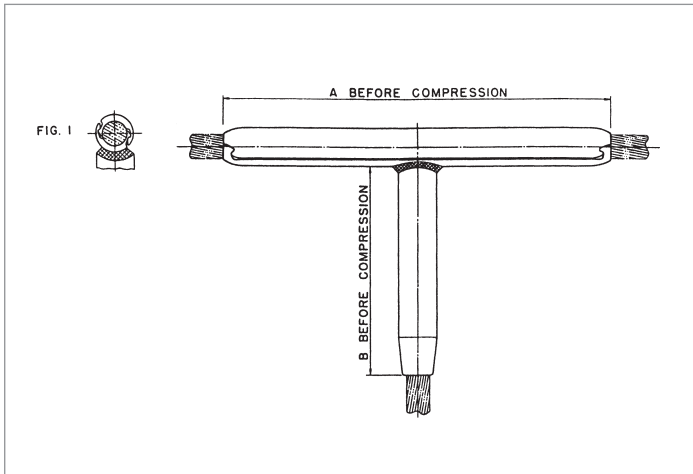

The 5500 Series Tee Connector is a permanent drop designed for ACSR conductors. The tee connector is fabricated from AFL seamless drawn aluminum.

The run portion incorporates an improved design of interlocking extrusions, providing a permanent grip on the conductor when compressed.

The branch portion of the tee connector is designed for limited tension use, maintaining a minimum of 40% of the ASTM rated strength of the conductor on which it is being used.

For die size sections 30AH and above, the end tapers of the compression portions of all compression accessories are supplied with a high voltage finish.

### Ordering Instructions

#### Step 1: Determine Run Catalog Number

Determine the run catalog number based on the conductor being used.

#### Step 2: Determine Branch Catalog Number

Determine the branch catalog number based on the conductor being used.

#### Step 3: Assemble Catalog Number



#### Example:

For 795 Drake Conductor in both Run and Branch, the complete catalog number is:

**5530.3 – 30.116**

#### Notes:

1. AFL Filler Compound (AFC) requirements are on page 115.
2. Installation Instructions for Open Run Tee Connectors are on page 144.

## Tee Connector—5500 Series for ACSR Conductors, Open Run (cont.)

CODE WORD	CONDUCTOR			CATALOG NUMBER		DIE SIZE	WEIGHT				DIMENSIONS			
	SIZE	STRANDING	DIA.	RUN CONDUCTOR	BRANCH CONDUCTOR	ALUMINUM HEX DIE	RUN		BRANCH		A		B	
	KCMIL	AL/ST	IN				LBS	KG	LBS	KG	IN	MM	IN	MM
Raven	1/0	6/1	0.398	5574	74.438	74AH	0.2	0.10	0.2	0.09	7.6	192	5.5	140
Quail	2/0	6/1	0.447	5574	74.438	74AH	0.2	0.10	0.2	0.09	7.6	192	5.5	140
Pigeon	3/0	6/1	0.502	5575	75.547	75AH	0.4	0.18	0.3	0.14	8.6	217	6.0	152
Penguin	4/0	6/1	0.563	5575	75.609	75AH	0.4	0.18	0.3	0.14	8.6	217	6.0	152
Waxwing	266.8	18/1	0.609	5576	76.656	76AH	0.7	0.30	0.5	0.23	10.0	254	6.5	165
Owl	266.8	6/7	0.633	5576	76.688	76AH	0.7	0.30	0.5	0.23	10.0	254	6.5	165
Partridge	266.8	26/7	0.642	5576	76.688	76AH	0.7	0.30	0.5	0.23	10.0	254	6.5	165
Ostrich	300.0	26/7	0.680	5576	76.719	76AH	0.7	0.30	0.5	0.23	10.0	254	6.5	165
Merlin	336.4	18/1	0.684	5576	76.719	76AH	0.7	0.30	0.5	0.23	10.0	254	6.5	165
Linnet	336.4	26/7	0.720	5576	76.781	76AH	0.7	0.30	0.5	0.23	10.0	254	6.5	165
Chickadee	397.5	18/1	0.743	5576	76.781	76AH	0.7	0.30	0.5	0.23	10.0	254	6.5	165
Linnet	336.4	26/7	0.720	5520.3	20.781	20AH	1.0	0.45	0.6	0.27	14.5	368	7.6	194
Oriole	336.4	30/7	0.741	5520.3	20.781	20AH	1.0	0.45	0.6	0.27	14.5	368	7.6	194
Chickadee	397.5	18/1	0.743	5520.3	20.781	20AH	1.0	0.45	0.6	0.27	14.5	368	7.6	194
Brant	397.5	24/7	0.772	5520.3	20.812	20AH	1.0	0.45	0.6	0.27	14.5	368	7.6	194
Ibis	397.5	26/7	0.783	5520.3	20.844	20AH	1.0	0.45	0.6	0.27	14.5	368	7.6	194
Lark	397.5	30/7	0.806	5520.3	20.844	20AH	1.0	0.45	0.6	0.27	14.5	368	7.6	194
Pelican	477.0	18/1	0.814	5524.3	24.875	24AH	1.7	0.77	0.8	0.36	15.5	394	8.3	210
Flicker	477.0	24/7	0.846	5524.3	24.938	24AH	1.7	0.77	0.8	0.36	15.5	394	8.3	210
Hawk	477.0	26/7	0.858	5524.3	24.938	24AH	1.7	0.77	0.8	0.36	15.5	394	8.3	210
Hen	477.0	30/7	0.883	5524.3	24.938	24AH	1.7	0.77	0.8	0.36	15.5	394	8.3	210
Osprey	556.5	18/1	0.879	5524.3	24.938	24AH	1.7	0.77	0.8	0.36	15.5	394	8.3	210
Parakeet	556.5	24/7	0.914	5524.3	24.969	24AH	1.7	0.77	0.8	0.36	15.5	394	8.3	210
Dove	556.5	26/7	0.927	5524.3	24.969	24AH	1.7	0.77	0.8	0.36	15.5	394	8.3	210
Eagle	556.5	30/7	0.953	5527.3	27.100	27AH	2.7	1.22	1.3	0.59	18.3	464	8.8	225
Peacock	605.0	24/7	0.953	5527.3	27.100	27AH	2.7	1.22	1.3	0.59	18.3	464	8.8	225
Squab	605.0	26/7	0.966	5527.3	27.100	27AH	2.7	1.22	1.3	0.59	18.3	464	8.8	225
Teal	605.0	30/19	0.994	5527.3	27.106	27AH	2.7	1.22	1.3	0.59	18.3	464	8.8	225
Swift	636.0	36/1	0.930	5527.3	27.100	27AH	2.7	1.22	1.3	0.59	18.3	464	8.8	225
Kingbird	636.0	18/1	0.940	5527.3	27.100	27AH	2.7	1.22	1.3	0.59	18.3	464	8.8	225
Rook	636.0	24/7	0.977	5527.3	27.106	27AH	2.7	1.22	1.3	0.59	18.3	464	8.8	225
Grosbeak	636.0	26/7	0.990	5527.3	27.106	27AH	2.7	1.22	1.3	0.59	18.3	464	8.8	225
Egret	636.0	30/19	1.019	5527.3	27.106	27AH	2.7	1.22	1.3	0.59	18.3	464	8.8	225
Flamingo	666.6	24/7	1.000	5527.3	27.106	27AH	2.7	1.22	1.3	0.59	18.3	464	8.8	225
Stilt	715.5	24/7	1.036	5530.3	30.109	30AH	3.3	1.50	1.7	0.77	19.1	486	9.4	240
Starling	715.5	26/7	1.051	5530.3	30.109	30AH	3.3	1.50	1.7	0.77	19.1	486	9.4	240
Redwing	715.5	30/19	1.081	5530.3	30.116	30AH	3.3	1.50	1.7	0.77	19.1	486	9.4	240
Coot	795.0	36/1	1.040	5530.3	30.109	30AH	3.3	1.50	1.7	0.77	19.1	486	9.4	240

## Tee Connector—5500 Series for ACSR Conductors, Open Run (cont.)

CODE WORD	CONDUCTOR			CATALOG NUMBER		DIE SIZE	WEIGHT				DIMENSIONS			
	SIZE	STRANDING	DIA.	RUN CONDUCTOR	BRANCH CONDUCTOR	ALUMINUM HEX DIE	RUN		BRANCH		A		B	
	KCMIL	AL/ST	IN				LBS	KG	LBS	KG	IN	MM	IN	MM
Tern	795.0	45/7	1.063	5530.3	30.116	30AH	3.3	1.50	1.7	0.77	19.1	486	9.4	240
Condor	795.0	54/7	1.093	5530.3	30.116	30AH	3.3	1.50	1.7	0.77	19.1	486	9.4	240
Drake	795.0	26/7	1.108	5530.3	30.116	30AH	3.3	1.50	1.7	0.77	19.1	486	9.4	240
Mallard	795.0	30/19	1.140	5530.3	30.122	30AH	3.3	1.50	1.7	0.77	19.1	486	9.4	240
Cuckoo	795.0	24/7	1.092	5530.3	30.116	30AH	3.3	1.50	1.7	0.77	19.1	486	9.4	240
Ruddy	900.0	45/7	1.131	5530.3	30.122	30AH	3.3	1.50	1.7	0.77	19.1	486	9.4	240
Canary	900.0	54/7	1.162	5530.3	30.122	30AH	3.3	1.50	1.7	0.77	19.1	486	9.4	240
Catbird	954.0	36/1	1.140	5530.3	30.122	30AH	3.3	1.50	1.7	0.77	19.1	486	9.4	240
Rail	954.0	45/7	1.165	5530.3	30.122	30AH	3.3	1.50	1.7	0.77	19.1	486	9.4	240
Cardinal	954.0	54/7	1.196	5530.3	30.125	30AH	3.3	1.50	1.7	0.77	19.1	486	10.1	256
Tanager	1033.5	36/1	1.186	5530.3	30.125	30AH	3.3	1.50	1.7	0.77	19.1	486	10.1	256
Ortolan	1033.5	45/7	1.212	5534.3	34.128	34AH	4.5	2.04	2.2	1.00	20.1	511	10.1	256
Curlew	1033.5	54/7	1.244	5534.3	34.134	34AH	4.5	2.04	2.2	1.00	20.1	511	10.1	256
Bluejay	1113.0	45/7	1.259	5534.3	34.134	34AH	4.5	2.04	2.2	1.00	20.1	511	10.1	256
Bunting	1192.5	45/7	1.302	5534.3	34.138	34AH	4.5	2.04	2.2	1.00	20.1	511	10.1	256
Bittern	1272.0	45/7	1.345	5536.3	36.144	36AH	5.0	2.27	2.5	1.13	21.0	533	10.6	270
Pheasant	1272.0	54/19	1.382	5536.3	36.147	36AH	5.0	2.27	2.5	1.13	21.0	533	10.6	270
Dipper	1351.5	45/7	1.386	5536.3	36.147	36AH	5.0	2.27	2.5	1.13	21.0	533	10.6	270
Martin	1351.5	54/19	1.424	5538.3	38.150	38AH	5.9	2.68	3.0	1.36	21.9	556	11.2	284
Bobolink	1431.0	45/7	1.427	5538.3	38.150	38AH	5.9	2.68	3.0	1.36	21.9	556	11.2	284
Plover	1431.0	54/19	1.465	5538.3	38.156	38AH	5.9	2.68	3.0	1.36	21.9	556	11.2	284
Nuthatch	1510.5	45/7	1.466	5538.3	38.156	38AH	5.9	2.68	3.0	1.36	21.9	556	11.2	284
Parrot	1510.5	54/19	1.506	5540.3	40.162	40AH	6.6	2.99	3.4	1.54	22.8	578	11.8	298
Lapwing	1590.0	45/7	1.504	5540.3	40.162	40AH	6.6	2.99	3.4	1.54	22.8	578	11.8	298
Falcon	1590.0	54/19	1.545	5540.3	40.162	40AH	6.6	2.99	3.4	1.54	22.8	578	11.8	298
Chukar	1780.0	84/19	1.602	5542.3	42.178	42AH	7.7	3.49	3.9	1.77	23.6	600	12.4	314
—	2034.0	72/7	1.681	5544.3	44.175	44AH	6.8	3.08	4.0	1.81	24.5	622	12.0	305
Bluebird	2156.0	84/19	1.762	5544.3	44.184	44AH	6.8	3.08	4.0	1.81	24.5	622	12.0	305
Kiwi	2167.0	72/7	1.737	5544.3	44.181	44AH	6.8	3.08	4.0	1.81	24.5	622	12.0	305
Thrasher	2312.0	76/19	1.802	5544.3	44.188	44AH	6.8	3.08	4.0	1.81	24.5	622	12.0	305
Joree	2515.0	76/19	1.880	5548.3	48.197	48AH	9.1	4.13	5.2	2.36	24.5	622	14.0	356