

THIS DRAWING AND ALL INFORMATION ON IT IS THE PROPERTY OF AFL. IT IS CONFIDENTIAL AND IT IS GIVEN TO YOU FOR A LIMITED PURPOSE AND MUST BE RETURNED UPON REQUEST. NEITHER THIS DRAWING OR ANY PART OF IT NOR ANY INFORMATION CONCERNING IT MAY BE COPIED, EXHIBITED, OR FURNISHED TO OTHERS NOR PHOTOGRAPHS TAKEN OF ANY ARTICLE FABRICATED OR ASSEMBLED FROM THE DRAWING WITHOUT THE CONSENT OF AFL.

ITEM NO:

DWG. NO:

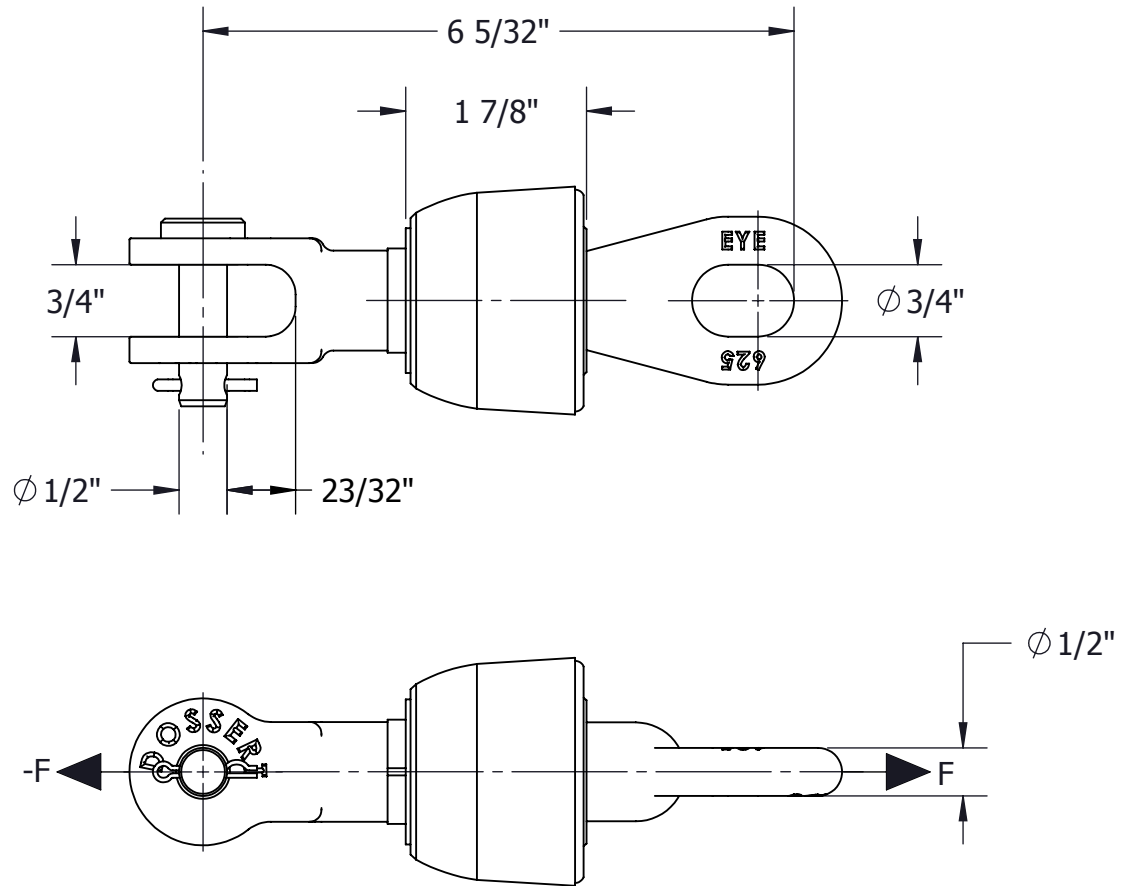

MATERIAL:

- Eye & Clevis - ALUMINUM ALLOY ASTM B26
- INSULATOR - GLASS REINFORCED POLYESTER
- LOCKWASHER, STUD & COTTER PIN - STAINLESS STEEL
- CLEVIS PIN - STEEL, GR 5, H.D.G*

MECHANICAL RATINGS:

MINIMUM ULTIMATE TENSILE LOAD F = 10,000 LBS

ELECTRICAL RATINGS:

- VOLTAGE RATING: 750 VDC
- LEAKAGE DISTANCE: 2.44 IN
- DRY FLASHOVER: 25 kV
- WET FLASHOVER: 15 kV (HORZ), 12 kV (VERT)
- ULTIMATE PUNCTURE: 35 kV (TESTED IN OIL)

WT: 2.6 LB

* = HOT DIP GALVANIZED

LOCATION	CONTRACT NO	CUST / CONTR
----------	-------------	--------------

REVISIONS				
REV	DESCRIPTION	DATE	BY	APR

DRN BY: HV
 DRN DATE: 10.15.12
 CHK BY: JL
 CHK DATE: 10.15.12
 PA 2017.270.0



INSULATOR, STRAIN, 750V SPOOL, CLEAR-EYE, 90 DEG, AL

REV	PART NO:	PFI-CE90P-AA	1 OF 1
0			