

TYPE XWWCT-AA Expansion Coupler

Expansion coupler is designed to compensate for expansion and contraction in long bus runs. An extruded pipe is provided to be field welded in place and provides alignment of bus.

Material

Aluminum Alloy

Notes

1. For dimension "E", refer to pages 11-12 in the General Information section.

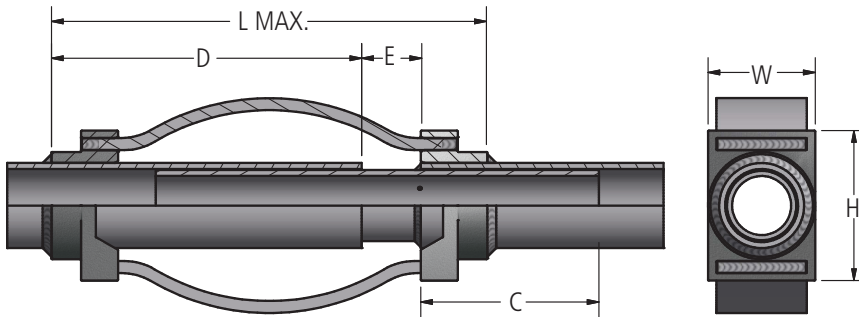
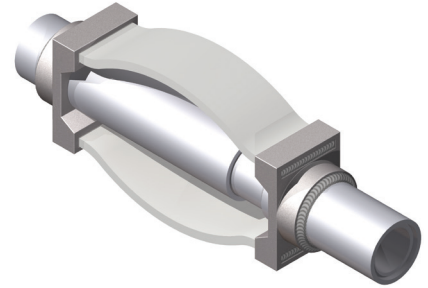

Ordering Information

Catalog Number		SPS/EHPS	Dimensions in inches				
SCH 40	SCH 80		C	D	H	L	W
XWWCT200-AA	XWWCT200E-AA	2	5 1/2	10 1/2	4 3/4	17 3/8	3 3/4
XWWCT250-AA	XWWCT250E-AA	2 1/2	6	10 1/2	5 1/16	17 1/2	3 5/8
XWWCT300-AA	XWWCT300E-AA	3	6 1/2	10 1/2	6 1/4	17 1/2	3 13/16
XWWCT350-AA	XWWCT350E-AA	3 1/2	7	10 1/2	6 7/8	17 1/2	3 11/16
XWWCT400-AA	XWWCT400E-AA	4	7 1/2	10 1/2	7 7/16	18	4 15/16
XWWCT500-AA	XWWCT500E-AA	5	8	10 1/2	9 1/8	18	6 1/16
XWWCT600-AA	XWWCT600E-AA	6	8	10 3/4	10	18	6 9/16

AFL's Dossert® product line offers a wide range of substation accessories in low voltage up to 765 kV applications in bronze or aluminum materials.