

ITEM NO

DWG NO
D-6451

THIS DRAWING AND ALL INFORMATION ON IT IS THE PROPERTY OF AFL. IT IS CONFIDENTIAL AND IT IS GIVEN TO YOU FOR A LIMITED PURPOSE AND MUST BE RETURNED UPON REQUEST. NEITHER THIS DRAWING OR ANY PART OF IT NOR ANY INFORMATION CONCERNING IT MAY BE COPIED, EXHIBITED, OR FURNISHED TO OTHERS NOR PHOTOGRAPHS TAKEN OF ANY ARTICLE FABRICATED OR ASSEMBLED FROM THE DRAWING WITHOUT THE CONSENT OF AFL.

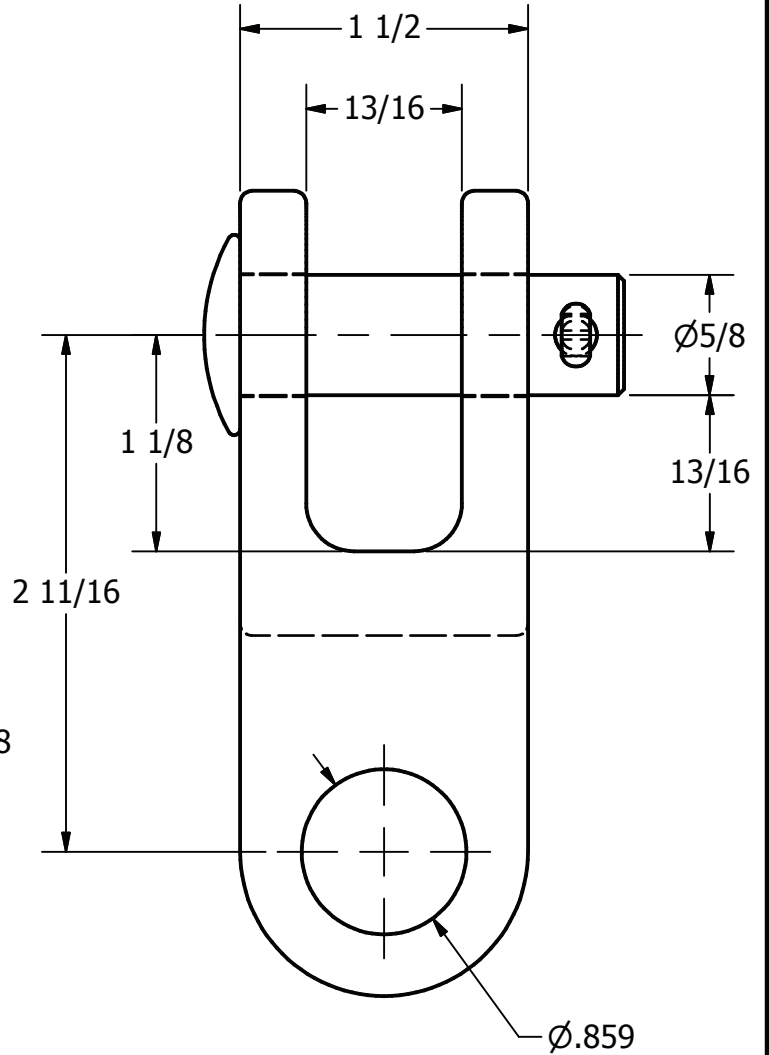
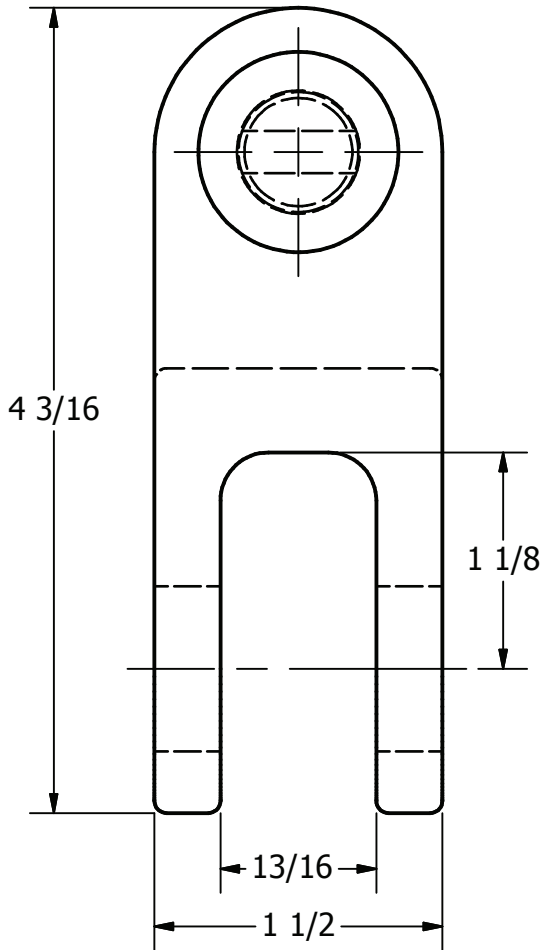
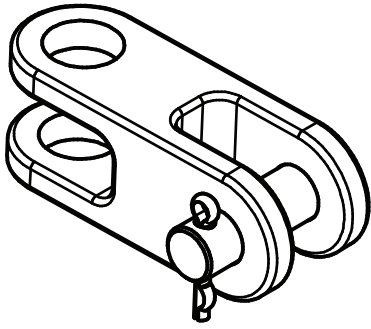

MATERIAL:
ALUMINUM BRONZE ASTM B30
CLEVIS PIN-GALVANIZED STEEL
COTTER KEY-STAINLESS STEEL

WORKING LOAD:
F=8,200 LBS

1.46 LBS

LOCATION					CONTRACT NO		CUST / CONTR	
REVISIONS								
REV	DESCRIPTION	DATE	BY	APR	LINK, DOUBLE CLEVIS 90°			
3	RE-DRAWN IN INVENTOR	1-28-10	LK	EP	DCLA63-86-90			
DRN BY: BB DRN DATE: 4-1-08 CHK BY: BB CHK DATE: 4-1-08					REV	3		1 OF 1