



30GBM GASOLINE HYDRAULIC PUMP

OPERATING & MAINTENANCE INSTRUCTIONS

REVISION: B - 0413
Part Sheet: 54408



MAILING / SHIPPING
104 Hidden Lake Circle
Spartangreen Business Park
Duncan, SC 29334
(800) 866-7385

PARTS OR SERVICE
Enerpac National
Accounts Service
(877) 864-7722

OPERATING INSTRUCTIONS AT A GLANCE

Before Operating Pump:

1. Use only cylinders , hoses and equipment rated at 10,000 psi.
2. Make sure all hose and fitting connections are tight and secure. Hoses cannot be kinked or twisted.
3. Oil level should be 1" from the top of the reservoir plate, with tool retracted and motor off.
4. Never operate the pump in advance at 10,000 psi without tool movement for more than 1 minute.

Continuing to operate the pump without tool movement will overheat the oil.

After Completing the Job:

1. Before disconnecting hoses, fittings, etc, be sure the tool is retracted and unloaded, then unplug the power cord.
2. Store the pump in a clean, dry area.

Periodic Maintenance:

1. Completely change the hydraulic oil and clean the oil filter screen and magnet (located in the reservoir) twice a year. (Use SIMPLEX oil only - Part #A01). Change the oil more frequently when used in extremely dusty areas or when the oil has been overheated. Using oil other than the SIMPLEX brand, may void the pump warranty.

SECTION I

SAFETY

1-1.

Working Pressure

The pump's maximum working pressure is 10,000 psi (700 kg/cm²). Make sure that all hydraulic equipment, hoses , etc. used with this pump are rated at 10,000 psi operating pressure.

1-2.

Hydraulic Connections

Never disconnect or connect any hydraulic hoses or fittings without first unloading the tool. Unplug the electrical cord of the pump and open all hydraulic controls to ensure that the system has been depressurized. If the system includes a gauge, double check the gauge ensure pressure has been released.

When making connections with quick disconnect couplings , make sure the couplings are fully engaged. Threaded connections such as fittings , gauges , etc. must be securely tightened and leak free.



CAUTION: Loose or improperly threaded fittings can be potentially dangerous if pressurized, however, severe over tightening can cause premature thread failure. Fittings need to be tightened secure & leak free. Never hold or stand directly in line with any hydraulic connections while pressurizing. Never grab, touch or in any way come in contact with a hydraulic pressure leak. Escaping oil can penetrate the skin and a serious injury can result.

Do not subject the hose to potential hazard such as sharp surfaces , extreme heat or heavy impact. Do not allow the hose to kink & twist. Inspect each hose for wear before each use.

SECTION II

INSTRUCTIONS BEFORE USE

Read carefully. Most malfunctions in new equipment are the result of improper operation and/or improper set-up assembly.

Preparation: Remove pump from shipping container -- but do not remove any plugs or valves until the unit is ready to be fully assembled to prevent dirt or foreign matter from contaminating system.

Inspection: Visually inspect all components for shipping damage. If any damage is found, notify carrier immediately.

2-1.

Gasoline, Oil and Fuel

1. Above 32 degrees Fahrenheit use S.A.E. 10 W 30 (Motor only)
2. Below 32 degrees Fahrenheit use S.A.E. 5 W 20 (Motor only)
3. Oil sump capacity - About 1.3 pints or check dip stick
4. Use clean, unleaded automotive gasoline (without alcohol)

2-2.

Hydraulic Connections:

Check hydraulic oil level to prevent possible pump burnout. Open the fill plug located at the top of the motor shroud. Remove inspection plug on cover plate. Oil level should be approximately 1" from top of reservoir plate with tools retracted and motor off. Add SIMPLEX oil as necessary. Do not mix different grades of oil.

Make sure all desired gauge, valve, hose and quick coupler connections are tight and secure before operating (**See Section 1-2**). The pumps pressure ports is 3/8 NPTF and are located just below the control valve. (**See Section 3-1**).

These pumps are equipped with a "popper" internal relief valve that makes an audible popping noise when 10,000 psi hydraulic pressure is reached.

The use of a pressure gauge is strongly recommended for normal operation of these pumps and required when the external adjustable relief valve pressures are changed. Mounted on a gauge adapter between the pump and cylinder, the gauge permits the operator to monitor tool operating pressures .

Do not exceed rated capacity of equipment connected to pump. Where shock loading or unsteady loads may cause overloading of cylinders, the operator must use larger capacity cylinders to provide additional operating margin.

2-3.

Starting Instructions (Gasoline Engine)

Throttle to choke position (extreme right): Grasp STARTER HANDLE and pull rope out slowly to engagement: Pull rope with a rapid, continuous full stroke and let rewind slowly, and do not allow to snap back. Move the control lever to "HIGH SPEED" position then to "RUN" as the engine warms.

SECTION III

OPERATION

3-1.

Control Valves:

3-Way Valve for Single Acting Tools Pushing lever to right directs pump output to right-hand port, To the tool. Pushing lever to left directs pump output to tank and allows the tool to open or retract. Center position is neutral/hold. Pump output is directed back to tank.

3-2.

Place valve in neutral/hold position (as described above) to prevent accidental tool movement. Start the pump and let the pump idle for a few minutes.

3-3.

Bleeding the hydraulic system air can be removed from the system by fully operating and retracting the hydraulic tool several times with the pump elevated so its reservoir is higher than the tool. Single-acting tools should be inverted. When the trapped air is removed from the hydraulic circuit, the tool will advance and retract smoothly. Sluggish tool action is usually the first sign of air in the system.

3-4.

Press the pendant control switch to activate the tool. Releasing the switch automatically releases the tool.

3-5.

Never operate the pump at 10,000 psi without tool movement for more than 1 minute because this could overheat the oil.

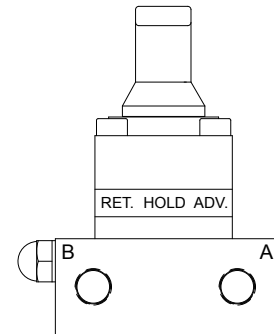

SECTION IV

MAINTENANCE

4-1.

Maintain Oil Level -- check hydraulic oil level every 30 hours of operation. Add SIMPLEX hydraulic oil when necessary. Oil level should be no more than 1" from top of reservoir plate with tool retracted and motor off.

Completely change oil at least twice a year. The following conditions require more frequent oil changes :

- a. Rigorous duty, where oil temperature may reach 140 F .
- b. High humidity environment and extreme changes in temperature that can result in condensation inside the reservoir.
- c. Dirty or dusty environments may contaminate the oil.

4-2.

Clean Oil Filter screen Once a Year

- a. Loosen and remove reservoir plate bolts . Lift pump unit off the reservoir, being careful not to damage the gasket.
- b. Remove debris from screen with a tooth brush.
- c. Blow dry and inspect, repeat cleaning as needed.

4-3. Keep areas around pump unobstructed to provide good air flow around the motor and pump. Keep the motor and pump as clean as possible.

SECTION V
TROUBLESHOOTING

If the procedures listed below do not remedy the problem, the pump will require service and should be taken to an Authorized SIMPLEX Service Center for repair.

PROBLEM	CAUSE - SOLUTION
<i>Sporadic Tool Action</i>	<ol style="list-style-type: none">1. Air in the hydraulic system. See Sec. 3-3 for correct bleeding procedure.2. Check reservoir oil level.
<i>Engine Will Not Start</i>	<ol style="list-style-type: none">1. Check manufacturers operating instructions.
<i>Noisy Operation</i>	<ol style="list-style-type: none">1. Air in system. (See Sec. 3-3 for bleeding procedure).2. Be sure the oil reservoir is filled to normal level.3. Check all points where air might leak into system.
<i>Pump Oil is Over Heating</i>	<ol style="list-style-type: none">1. Oil viscosity too high. Replace with SIMPLEX oil.2. Check for high pressure leakage at relief valve or plugs .3. Oil level is low. Fill reservoir to normal level or refit pump with larger reservoir.
<i>Pump Runs but Will Not Pump Oil or build full pressure</i>	<ol style="list-style-type: none">1. Pump is not primed. Run pump a few minutes tipping from side to side.2. Internal leakage. Take to SIMPLEX Authorized Service Center for repair.3. Damaged O-Rings. Take to nearest Simplex Authorized Service Center.4. Defective control valve. (Troubleshoot separately).

PUMP ASSEMBLY - 7630011

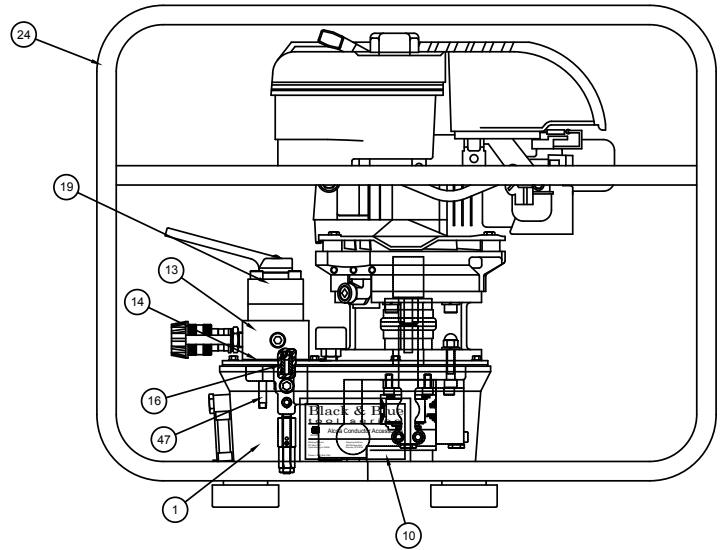
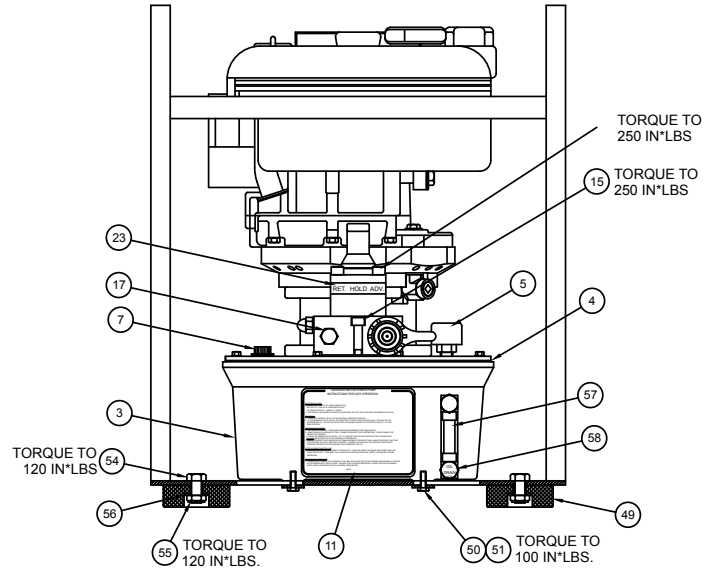
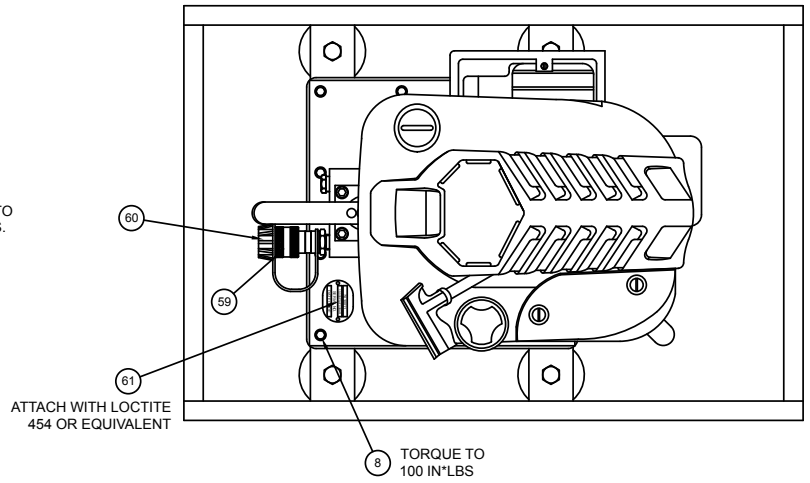
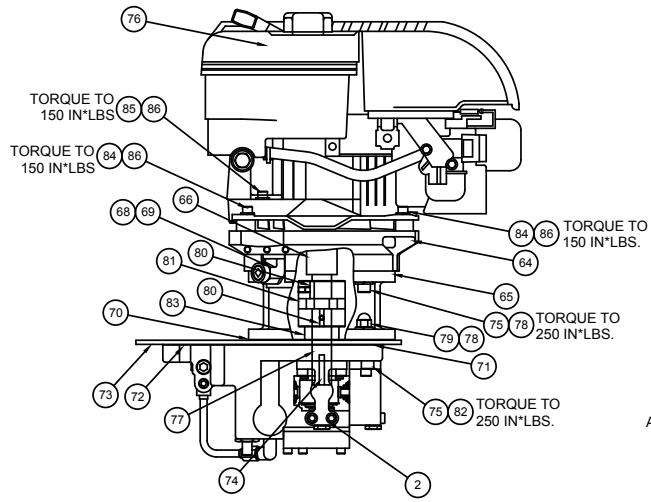

PUMP ASSEMBLY - 7630011

Item #	Part #	Name	Qty.		Item #	Part #	Name	Qty.
	44278	FUNNEL	1		58	44779	LEVEL GAUGE DECAL	1
1	AO1	HYD OIL-1 GAL.	2		59	40858	FEMALE COUPLER 3050-3	1
2	44724SS	PUMP ASM 4P W/POPPER	1		60	CR215	DUST CAP	1
3	69285BSS	2 GAL RESVR. ALCOA	1		61	44735	POWER PUMP METAL TAG	1
4	66014	GASKET	1		64	44732	PLATE RISER 6 HP	1
5	68000	BREATHER VENT BF-4	1		65	44729	MOTOR ADAPTOR	1
7	68571SS	FILLER PLUG	2		66	44733	SPACER-COUPLING 6HP	1
8	69249	SCREW 1/4-20 X 3/4 S.T.	12		68	89137	NIPPLE-CLOSE 3/8	1
10	44823Z	ALCOA DECAL	2		69	18107	F7 94805 318 90 DEGR	1
11	44815	GEN SAFE USE GAS LBL	1		70	66012	GASKET-MOTOR	1
13	44422SS	4 WAY MAN ASM W/REL	1		71	68231	GASKET-PUMP @ MOTOR	1
14	69242	VALVE GASKET	1		72	68551	GASKET-PUMP @ VALVE	1
15	93599	SHCS 3/8-16 X 2 1/2	3		73	44451	COVER PLT 2G W/REL	1
16	69378SS	VAL ADP W/ CHECK ASM	1		74	69026	PIN,DOWEL 3/16 1" LONG	1
17	87145	PLUG	1		75	84692	SHCS 3/8-16 X 1.75	6
19	45643SS	4W VALVE ASM. MANUAL	1		76	44731	ENGINE BRIGGS 6.5HP INTEK ZG5	1
23	68069	LABEL, POSITION	1		77	69515	STUB SHAFT 3HP FMH	1
24	69131	ROLL CAGE	1		78	93943	LOCK WASHER	6
47	68917	PIPE NIPPLE 1/8 NPT	1		79	44720	ACORN NUT 3/8-16 PLT	2
49	69133	RUBBER FOOT MACH.	4		80	88464	KEY 3/16 X 3/16 X 3/4LG	2
50	45751	HHCS 1/4-20 X .75 W/NYLON S.S	4		81	44812	COUPLER L090 7/8X7/8	1
51	45185	1/4 FENDER WASHER	4		82	85726	GASKET 25/64X19/32	2
54	45746	HHCS 1/2-13 X 1.00 S.S	4		83	44861	SPACER COUPLING	1
55	45747	HEX NUT 1/2-13 W/NYLON THIN SS	4		84	93590	SHCS 5/16-18 X 1.25LG	2
56	45748	SS FLAT WASHER 1/2	4		85	87412	SHCS 5/16-18 X 2 1/4	1
57	69284	GAGE LIQUID LEVEL	1		86	93942	5/16" LOCK WASHER ZINC PLATE	3

SUB PUMP ASSEMBLY - 44724SS

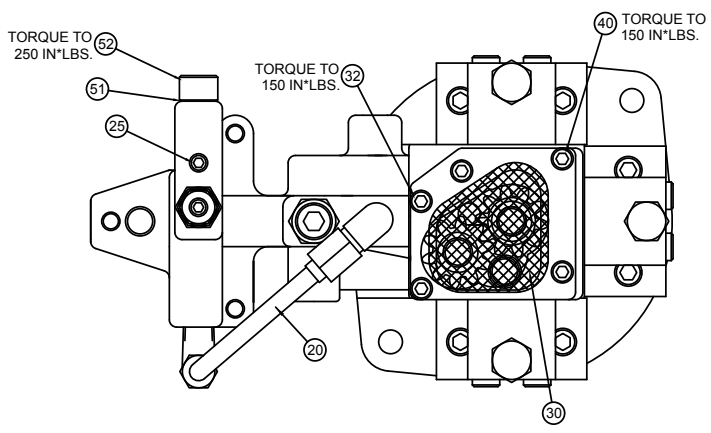
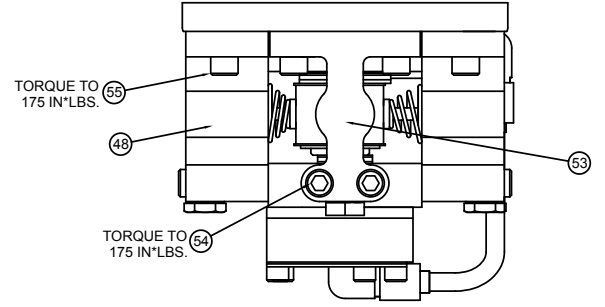
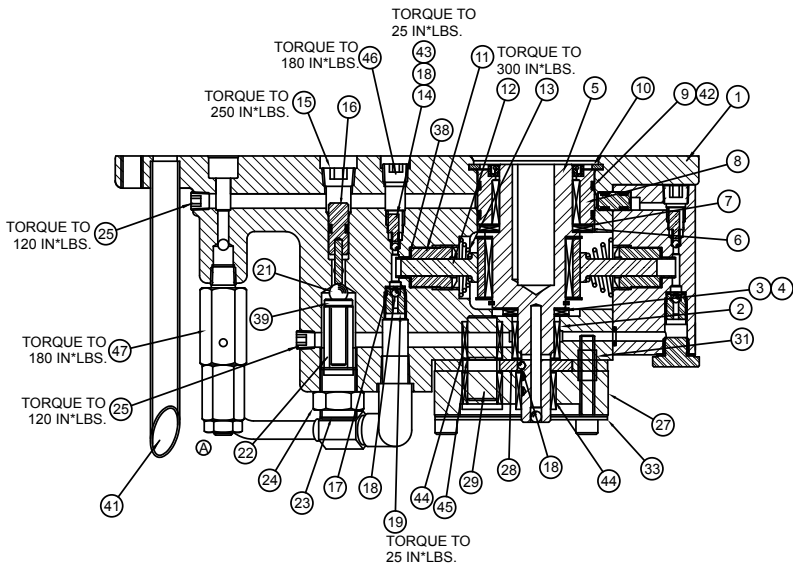
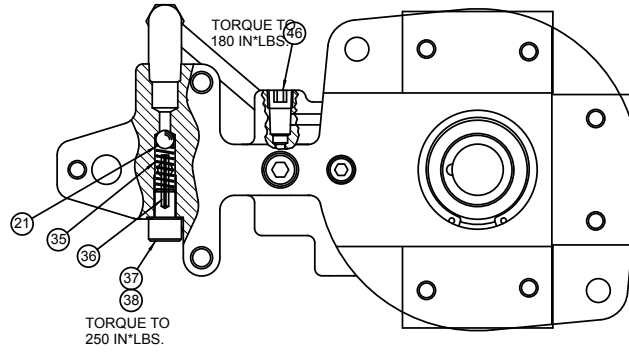

NOTES:
 SET UNLOADING VALVE @ 1,200 PSI

SUB PUMP ASSEMBLY - 44724SS

Item #	Part #	Name	Qty.
1	44917	PUMP BODY 4 PISTON	1
2	68360	BEARING ROLLER 5/8x13/16x5/8 WIDE	1
3	66033	THRUST BEARING	1
4	66474	THRUST WASHER	2
5	68906SS	SHAFT-ECC ASM 7/8	1
6	66106	THRUST BEARING	1
7	66108	THRUST WASHER	2
8	68829SS	ADAPTER-SHAFT ASM	1
9	56020322	O-RING 1 7/8X2" URE	2
10	68978	RETAINING RING	1
11	68915	ADAPTER-.210 PISTON	1
12	68830	PISTON-.210 DIA	1
13	68340	SPRING, PISTON	1
14	68810	BALL STOP	1
15	93950	1/4 SOC PIPE PLUG	1
16	43766SS	UNLOADING PISTON ASSEMBLY	1
17	66043	BALL RETAINER	1
18	90906	1/8" DIA. BALL REF WM1584020	5
19	66046	INTAKE SEAT	1
20	68851	TUBE ASM	1
21	91701	5/16" DIA. BALL REF S116	2
22	43671	UNLOADING SPRING	1
23	43674	SET SCREW UNLOADING VALVE	1
24	43675	HEX NUT UNLOADING VALVE	1
25	97641	1/16 SOC PIPE PLUG	3
27	68849	PLATE-BOTTOM	1
28	68848S	GEAR SET 3/16" CLYDESDALE PUMP	1
29	68850	SHAFT-IDLER	1
30	68921	SCREEN	1
31	68894	TUBE-GUIDE .11	2
32	89148	SHC SCREW	1
33	68927	PLATE-SCREEN MTG.	1
35	68225	SPRING	1
36	S81332	PIN ROLL .13 X 15/16	1
37	68226	SCREW, BALL STOP	1
38	85726	GASKET 25/64X19/32	2
39	43673	SPRING CAP UNLOADING VALVE	1
40	68255	CAP SCREW	4
41	68569	TUBE RETURN	1
42	69513	SHAFT ADP BACKUP WAS	2
43	66042	SPRING	1
44	68891	BEARING ROLLER 1/2x11/16x1/2 WIDE	3
45	68892	RING-RETAINING	1
46	81093	1/8 FLUSH PLUG W/SEALANT	2
47	45295SS	POPPER RELIEF VALVE ASSEMBLY	1
48	68502SS	PISTON BLK .225	2
51	86269	GASKET 29/64 X 5/8	1
52	68940	SHCS 7/16-20 x .50	1
53	68832SS	PISTON BLK .210	1
54	69392	SOCKET HEAD CAPSCREW	6
55	82687	SHCS 5/16-24 X 5/8	6

ADAPTER SHAFT ASSEMBLY - 68829SS

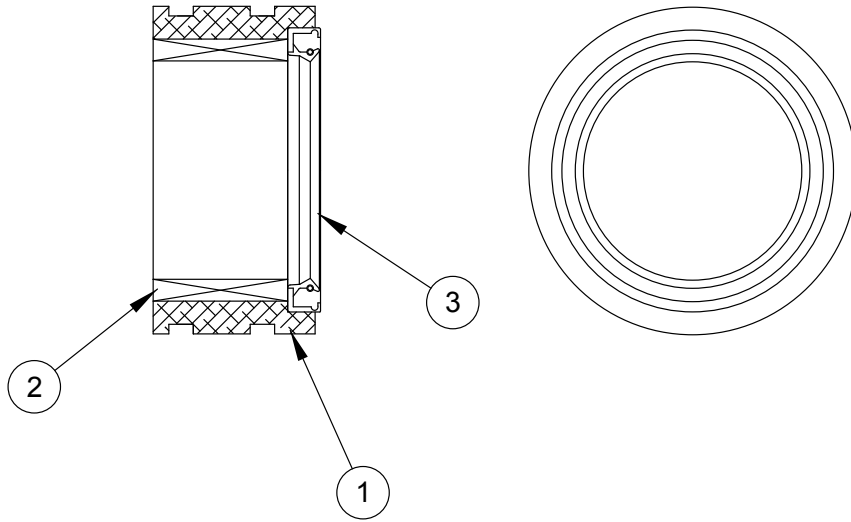

Item #	Part #	Name	Qty.
1	68912	ADAPTER-SHAFT	1
2	66030	BEARING ROLLER 1 1/4x1 1/2x3/4 WIDE	1
3	68901	SEAL-SHAFT	1

UNLOADING PISTON ASSEMBLY - 43766SS

ASSEMBLE WITH
LOCTITE 609

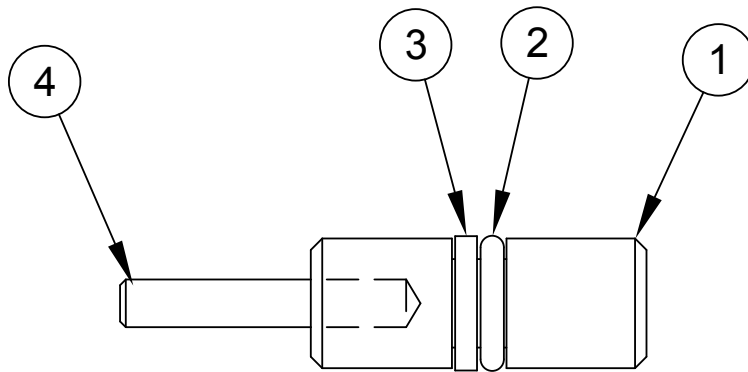

Item #	Part #	Name	Qty.
1	43765	UNLOADING PISTON	1
2	S5602009	O RING	1
3	S43768	BACKUP WASHER	1
4	43686	DOWEL PIN 1/8 DIA X 3/4	1

POPPER VALVE ASSEMBLY- 45295SS

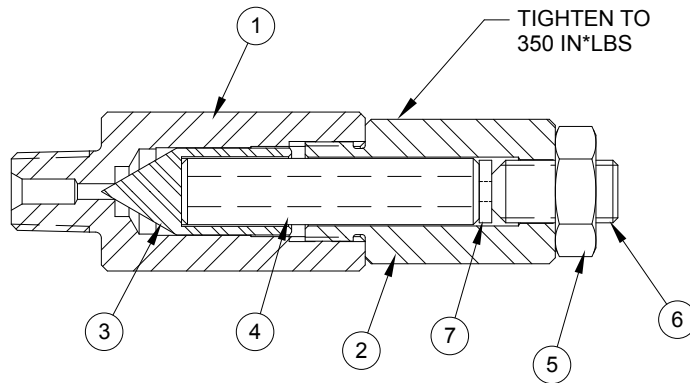

NOTES:
 -POPPET SEAT ON CARTRIDGE, TO BE COINED PRIOR TO ASSEMBLY.
 -USE SPECIAL COINING TOOL OR 1/8" BALL BEARING.
 -SET POPPER VALVE TO 10,500-10,800 PSI USING A 100 CU.IN. PUMP.

Item #	Part #	Name	Qty.
1	44764	POPPER BODY 1/8 NPT	1
2	45262	POPPER VALVE ADAPTER	1
3	69982	POPPET	1
4	45263	POPPER RELIEF SPRING	1
5	93872	HEX JAM NUT 5/16-24	1
6	45296	SET SCREW 5/16-24 X 5/8 CUP	1
7	46521	WASHER 5/16 O.D.	1

VALVE ADAPTER ASSEMBLY - 69378SS

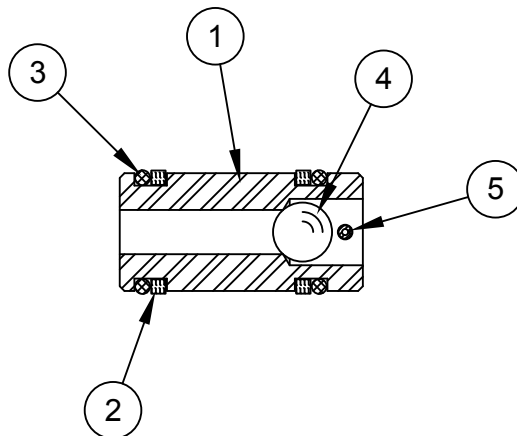

Item #	Part #	Name	Qty.
1	69377	VALVE ADP W/ CHECK	1
2	S65881	SPLIT BACK UP	2
3	S5602012	O RING -012, 70	2
4	92549	1/4" DIA. BALL	1
5	81330	ROLL PIN 1/16 X 7/16	1

PISTON BLOCK ASSEMBLIES - 68502SS & 68832SS

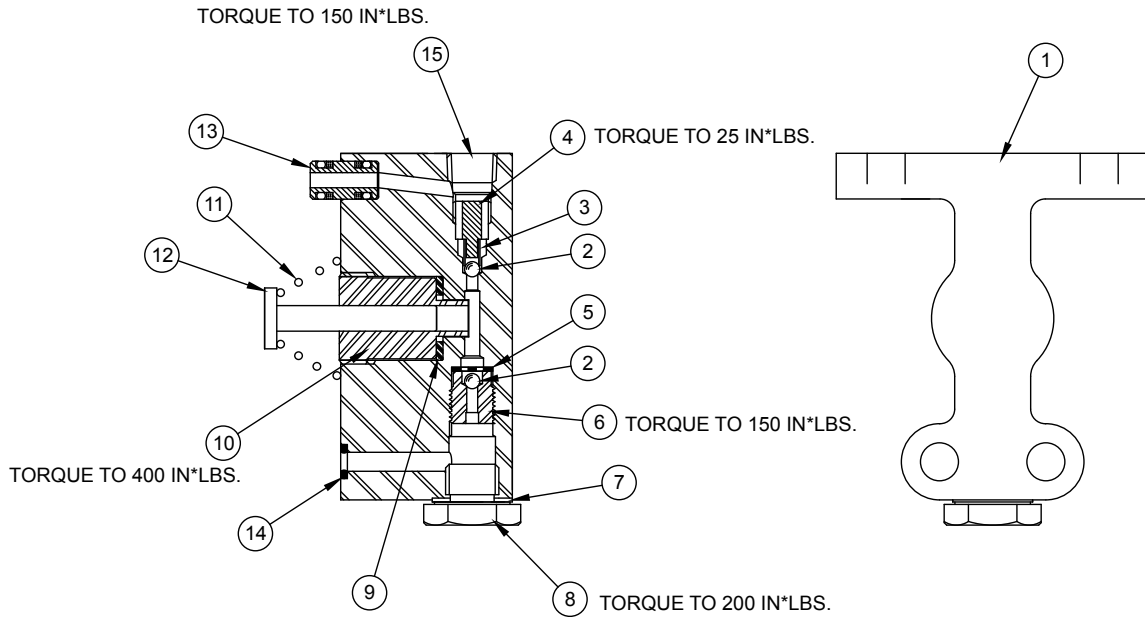

	68502SS	68832SS		
Item #	Part #	Part #	Name	Qty.
1	68501	68501	PISTON BLOCK MACH'G	1
2	90906	90906	1/8" DIA. BALL REF WM1584020	2
3	66042	66042	SPRING	1
4	68810	68810	BALL STOP	1
5	66043	66043	BALL RETAINER	1
6	66046	66046	INTAKE SEAT	1
7	86269	86269	GASKET 29/64 X 5/8	1
8	68825	68825	PLUG PISTON BLOCK	1
9	85726	85726	GASKET 25/64X19/32	1
10	68945	68915	ADAPTER PISTON	1
11	68340	68340	SPRING, PISTON	1
12	67868	68830	PISTON	1
13	68970SS	68970SS	ADAPTER ASSY.	1
14	S5602008	S5602008	O-RING (.19x.31x.06)BUNA	1
15	81093	81093	1/8 FLUSH PLUG W/SEALANT	1

VALVE MANIFOLD ASSEMBLY - 44422SS

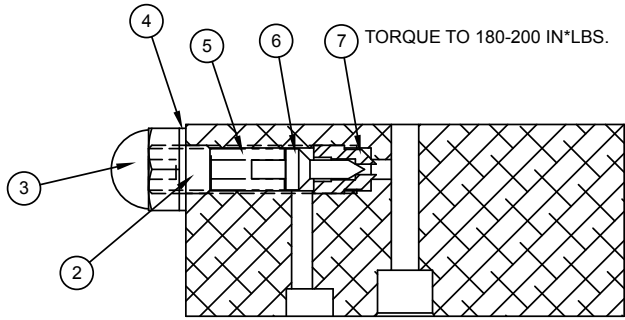

SECTION A-A

NOTES:

- SET RELIEF @ 12,000 - 12,100 PSI.

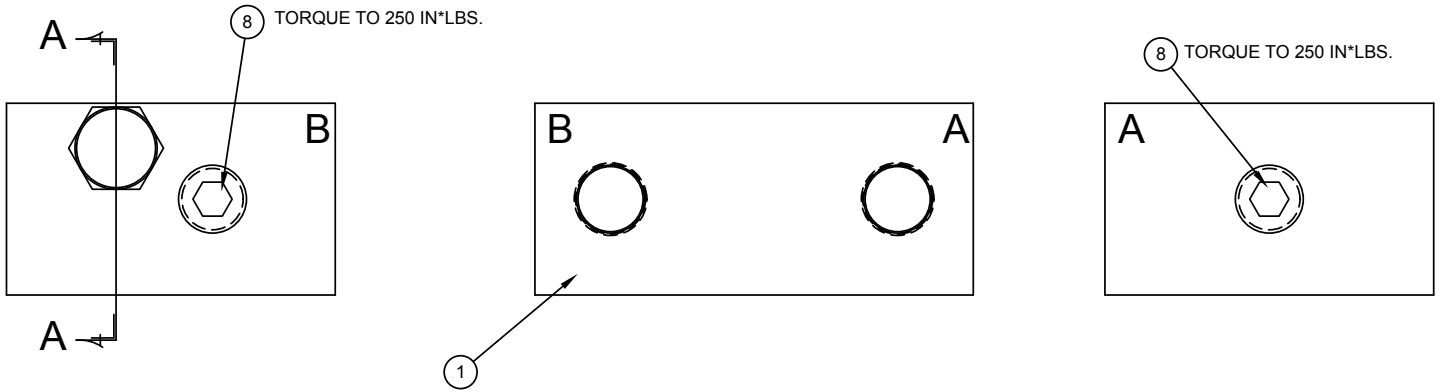

Item #	Part #	Name	Qty.
1	44420	4W MANIFOLD W/RELIEF	1
2	69104	ADJUSTING SCREW	1
3	69105	ACORN NUT 7/16-20 PL	1
4	69124	WASHER 7/16 NYLON	1
5	66085	SPRING - RELIEF VALVE	1
6	68003	CONE - EXT RELIEF	1
7	68004	SEAT - EXT RELIEF	1
8	84084	PIPE PLUG 3/8" FLUSH	2

CONTROL VALVE ASSEMBLY - 45643SS

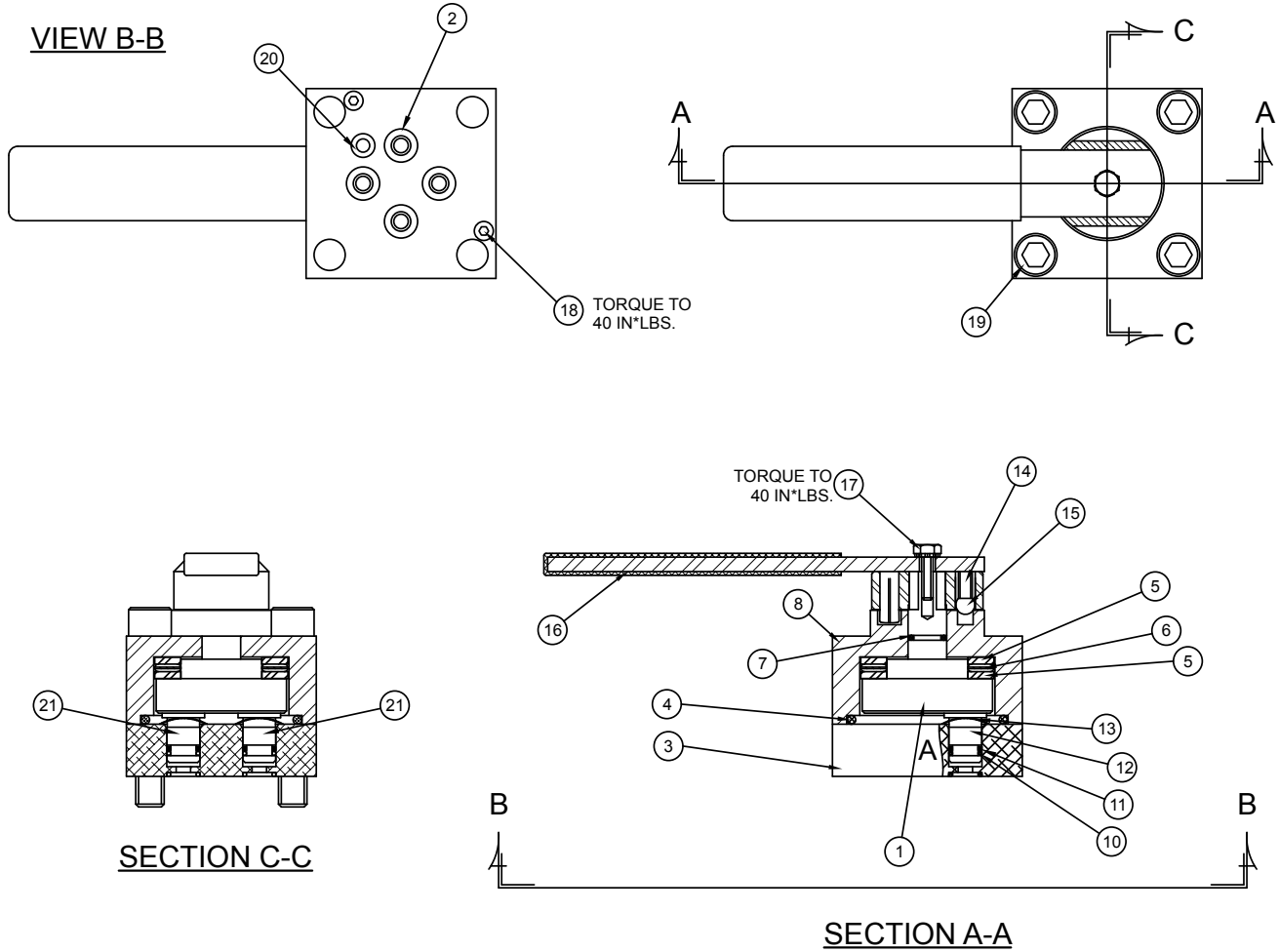

Item #	Part #	Name	Qty.
1	43762	VALVE ROTOR	1
2	56020112	O-RING 5/16X7/16 URE	4
3	68180	SUBPLATE- VALVE	1
4	S5602225	REC SEAL	1
5	68026	THRUST WASHER	2
6	68155	THRUST BEARING	1
7	S5602012	O RING -012, 70	1
8	69135	UPPER VALVE BLOCK	1
10	S5602011	O RING	3
11	65882	BACK UP WASHER	3
12	68029	SHEAR SEAL	1
13	68028	SPRING WASHER	3
14	68025	DETENT SPRING	1
15	92549	1/4" DIA. BALL	1
16	45919	VALVE HANDLE ASM.	1
17	DS2115046	SCREW 10-24 X 0.50 HEX FLANGE	1
18	85317	SHCS #6-32 X 5/8 LG	2
19	93598	SHCS 3/8-16 X 2 1/4	4
20	S5602008	O-RING (.19x.31x.06)BUNA	1
21	68181	SHEAR SEAL	2

