



ENTERPRISE FIBER OPTIC CABLE

Interconnect | Indoor | Indoor/Outdoor
Outdoor | ADSS | MicroCore®

Founded in 1984, AFL is an international manufacturer providing end-to-end solutions to the energy, service provider, enterprise, hyperscale and industrial markets as well as several emerging markets.

AFL's products are in use in over 130 countries and include fiber optic cable and hardware, transmission and substation accessories, outside plant equipment, connectivity, test and inspection equipment, fusion splicing systems and training.

AFL also offers a wide variety of services supporting data center, enterprise, wireless and outside plant applications.

AFL is dedicated to bringing our customers a quality product as well as delivering superior value.



Table of Contents

Inside Plant Premise Cable

Specifying AFL Premise Optical Cables	3
Fiber-In-A-Box	4
Simplex Cable	5
Zipcord, Dual-link and Micro-Dual Cable	7
QUAD-link and Circular Premise Cable	9
Multi-Unit Circular Premise Cable	11
Low Smoke Zero Halogen Distribution Cable	13
Interlocking Armor Technology	15
Armored Tight Buffered Circular Premise Cable	17

MicroCore® Cable

Interconnect Premise MicroCore Cable	19
Interconnect Premise MicroCore Cable with SWR® Technology	21
Ruggedized MicroCore Cable	23
Ruggedized MicroCore® Cable with SWR Technology	25
Sub-unitized Premise MicroCore 2.0	27
Sub-unitized Premise MicroCore 3.0	
Base-12	29
Base-16 and Base-24	31
with SpiderWeb Ribbon (SWR) Technology	33
Ultra HD MicroCore® Riser Fiber Optic Cable	36

Enterprise Blown Fiber (eABF®) Cable

eABF Solutions	38
eABF Products	39
Lifetime Warranty on End-to-End Fiber Optic Systems	40
Enterprise Blown Fiber (eABF) Cable	41
eABF® SWR® Enterprise Blown Fiber Cable	44

Indoor/Outdoor (I/O) Premise Cable

Indoor/Outdoor Riser Sub-unitized MicroCore Cable	46
Indoor/Outdoor Riser Sub-unitized MicroCore Cable with SWR	48
MDU Drop Cable	50
Indoor/Outdoor Riser Tight Buffered Cable	51
Indoor/Outdoor Multi-unit Riser Tight Buffered Cable	53
Indoor/Outdoor Plenum Distribution Cable	55
Indoor/Outdoor Multi-unit Plenum Tight Buffered Cable	57
Indoor/Outdoor Armored Tight Buffered Circular Premise Cable	59

Outside Plant (OSP) Cable

High-Density Cable

Wrapping Tube Cable (WTC) with SpiderWeb Ribbon® (SWR®)	
250 µm Fiber/250 µm Pitch	61
200 µm Fiber/250 µm Pitch	64
OSP WTC/SWR – 200 µm Fiber/200 µm Pitch	66
Flame-Retardant	
RI Indoor WTC/SWR – 200 µm Fiber/250 µm Pitch	68
RI Indoor WTC/SWR – 200 µm Fiber/200 µm Pitch	71
RIO Indoor/Outdoor WTC/SWR – 200 µm Fiber/250 µm Pitch	74
RIO Indoor/Outdoor WTC/SWR – 200 µm Fiber/200 µm Pitch	77
LM-Series OSP MicroCore® Cable	80
LM200-Series OSP MicroCore® Cable	82
LMHD-Series OSP Heavy Duty MicroCore® Cable	84

OSP Loose Tube Cable

LV-Series Indoor/Outdoor Riser Loose Tube – Single Jacket	86
LQ-Series Plenum-rated Indoor/Outdoor Loose Tube	88
All-Dielectric Armored Rodent-Resistant OSP Loose Tube (LN Series)	90
Non-Armored OSP Loose Tube (LE Series SJ)	92
Gel-Free Non-Armored OSP Loose Tube (LE Series Gel-Free SJ)	94
Non-Armored Loose Tube Cable – Double Jacket (LE Series DJ)	96

All-Dielectric Self-Supporting Cable (ADSS)

Flex-Span® ADSS Fiber Optic Cable	98
---	----

All-Dielectric Self-Supporting Cable (ADSS)

Mini-Dead Ends	100
Mini-Bracket	101
Mini Formed Wire Tangent Support (FTS)	101
Wedge Dead End	102
Limited Tension Formed Wire Dead End for ADSS Cable	103
Medium Tension Dead End for ADSS Cable	104
Trunnion Assemblies—Single and Double Cables	105
ADSS Suspension Unit	107
Formed Wire Suspension for ADSS Cable	108
AGC Series ADSS Downlead Clamp	109
AVD Series Spiral Vibration Dampers	111
Fiber Storage Units for ADSS Fiber Optic Cable	113

Tactical Cable

Tactical Tight Buffered Cable	114
---	-----



Specifying AFL Premise Optical Cables

Cable Type	Jacket Type	Fiber Count	Fiber Type*	Unit Jacket Diameter	Print	Jacket Color	Sub-Unit Color	Fiber Construction	Additional Information*
C	R	012	5	55	1	0	0	1	AIA
B = Breakout C = Circular Premise Cable D = Dual-link R = Ruggedized MicroCore G = Sub-unitized Microcore K = Indoor/Outdoor S = Simplex U = Quad-link W = Ribbon X = Tactical Z = Zipcord	R = Riser P = Plenum E = LSZH 5 = Polyurethane F = Furcation B = Bare	004 = 4 fiber 006 = 6 fiber 012 = 12 fiber etc.	5 = 50 µm MM 6 = 62.5 µm MM L = OM3 C = OM4 W = OM5 9 = Single-mode * more available	55 = 5.5 mm	1 = AFL standard 2 = Non-standard U = Unprinted	0 = Standard 1 = Blue 2 = Orange 3 = Green 4 = Brown 5 = Slate 6 = White 7 = Red 8 = Black 9 = Yellow A = Violet B = Rose C = Aqua	0 = Standard 1 = Blue 2 = Orange 3 = Green 4 = Brown 5 = Slate 6 = White 7 = Red 8 = Black 9 = Yellow A = Violet B = Rose C = Aqua	1 = Standard Strip 3 = EZ strip 6 = 600 µm Tight Buffer 8 = Medium Strip B = Bare G = Elastomer over 250 µm H = Elastomer over 500 µm U = 500 µm Bare Fiber	AIA = Aluminum Interlocking Armor AIAR = Aluminum Interlocking Armor/Riser Jacket AIAP = Aluminum Interlocking Armor/Plenum Jacket * or other customer specific information

* Different configurations, fiber types, etc. may be available. Please consult your AFL representative for more details.

Cable Print Examples



AFL Standard Print

AFL OPTICAL CABLE 1-800-AFL-FIBER 50/125 12 FIBER (UL) TYPE OFNR c(UL) RoHS MM/YY 000000 METERS REEL NUMBER

Generic Print

OPTICAL FIBER CABLE 50/125 12 FIBER E121250 TYPE OFNR (UL) c(UL) RoHS-COMPLIANT MM/YY 000000 METERS REEL NUMBER

* Custom print is available.

Icon Legend



AFL can add Interlocking Armor to any type of fiber optic cable.



Fiber optic cable that is approved for mining applications.



AFL stocks many of our most popular cables for your convenience. Please contact us at 800-AFL-FIBER or AFLPremiseStock@AFLGlobal.com for more details.





Fiber-In-A-Box

AFL's "Fiber-In-A-Box" solution offers contractors lightweight, easy to use cable packaging with "out of the box" disbursement of fiber cable. No reel supports or pay-off's are required. Simply set the box down in a convenient place, unlock the built-in braking mechanism and begin pulling. Adjust the braking mechanism to apply the amount of pulling tension required. Stack and configure boxes together to disburse cable from several reels at the same time. Available in lengths of 1000, 2000 and 3000 feet, this unique cable package solution will save contractors valuable time and cost.

Features

- Easy count printing – descending marks (feet or meters) indicating amount of cable remaining on reel
- Light weight and easy to transport with grips on both sides of the box for easy handling
- Eliminates the need for reel supports and cable spooling equipment
- Unique braking mechanism allows reel to be locked in place within carton during transport and provides control of tension during cable pulls
- Boxes can be stacked and configured to support easy pay-off of multiple cable runs
- Warning under feed-through slot reminds installers of proper pulling methods for optical cable
- Factory packaging ensures cable is not "over-stressed" in non-factory cable cutting operations where personnel may not be sensitive to proper handling of fiber optic cable
- Available in lengths of 1000, 2000 and 3000 feet, depending on cable diameter
- Easy access to reel from top allows installers to repackage excess cable removed from box
- Easy way to organize, store and manage short lengths of excess cable
- Box size: 15" H x 13" W x 15.25" D

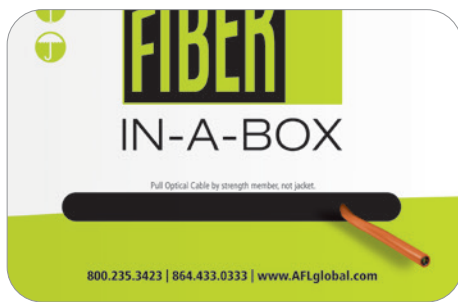

Applications

- Horizontal cabling / Fiber-to-the-Desk
- Fiber Drops within MDUs
- Short-to-medium length cable runs between buildings

Ordering Information

Add suffix "-XMFBOX" to AFL part number to specify "Fiber-In-A-Box" solution, where X indicates length of the cable in thousands of feet (1, 2, or 3).

AFL Cables available for purchase with "Fiber-In-A-Box" packaging solution:

FIBER COUNT	CABLE TYPE	MF – THOUSANDS OF FEET
1	Simplex, 2 mm - 3 mm	1 - 3
2	Zipcord, 1.6 mm - 3 mm	1 - 2
2	Dual-Link (Round) 2.4 mm - 4.8 mm	1 - 2
4	Quad-Link	1
6, 12	Circular Premise Cable	1
1, 2	Indoor/Outdoor MDU Drop Cable	1 - 3
4, 6, 12	Indoor/Outdoor Tight Buffer Cable	1



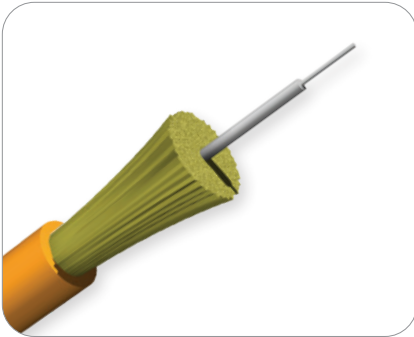

Simplex Cable

Simplex fiber optic cables provide the strength and flexibility for fiber interconnect applications. AFL offers a broad selection of simplex cordage including Plenum, Riser and LSZH, available in multiple diameters. Our simplex cable is tested to meet Telcordia GR-326 when used in connectorized assemblies. AFL provides customized performance for jacket stiffness and flexibility, diameter, print legend, jacket color and tight buffer strippability. The easy strip option allows removal of up to one meter of 900 µm material without stripping the fiber’s 250 µm coating.

Features

- 1.6 mm to 2.9 mm outside diameter available
- Easy strip option available
- Custom diameters, colors, and print legends

Applications

- Trunking lines direct to telecommunications closet
- Fiber patch panels within communications closets
- Long haul networks
- Links between electronic equipment and fiber patch panels
- Connectorized patch cords for cross connect applications

Cable Components

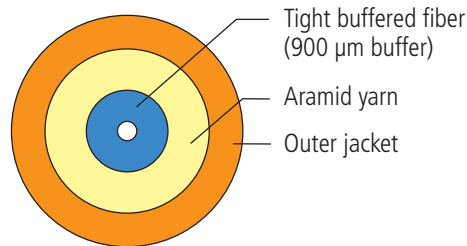

Fiber Specifications

CORE SIZE/FIBER TYPE	ISO/IEC	MAXIMUM ATTENUATION (dB/km)			OVERFILL LAUNCH MIN. BANDWIDTH (MHz•km)		EMB _c (MHz•km)	GIGABIT ETHERNET MAX. LINK DISTANCE (meters)		10 GIGABIT ETHERNET MAX. LINK DISTANCE (meters)	
		850 nm	1300 nm	1550 nm	850 nm	1300 nm		850 nm	1300 nm	850 nm	1300 nm
		(6) 62.5 Giga-Link™ 300	OM1	3.5	1.2	N/A		200	600	N/A	300
(5) 50 Giga-Link™ 600	OM2	3.5	1.5	N/A	500	500	N/A	600	600	82	—
(L) 50 Laser-Link 300	OM3	3.0	1.2	N/A	1,500	500	2,000	1,000	550	300	—
(C) 50 Laser-Link 550	OM4	3.0	1.2	N/A	3,500	500	4,700	1,040	550	550	—
(W) AFL Wideband Multimode	OM5	3.0	1.2	N/A	3,500	500	4,700	1,040	550	550	—
(9) Single-mode (ITU G.652.D/G.657.A1)	OS2	N/A	0.5	0.5	N/A	N/A	N/A	N/A	5,000	N/A	10,000

continued
→

Simplex Cable

Mechanical Data

AFL NO.	FIBER COUNT	NOMINAL DIAMETER inches (mm)	WEIGHT		TENSION lbs (N)		BENDING RADIUS inches (cm)		
			RISER lbs/1000 ft (kg/km)	PLENUM lbs/1000 ft (kg/km)	INSTALLATION	LONG TERM	INSTALLATION	LONG TERM	
PLENUM	SP001★301#01	1	0.11 (2.9)	—	6 (9)	22 (100)	7 (30)	2.0 (5.0)	1.2 (3.0)
	SP001★241#01	1	0.09 (2.4)	—	5 (7)	22 (100)	7 (30)	2.0 (5.0)	1.2 (3.0)
	SP001★201#01	1	0.08 (2.0)	—	3 (5)	22 (100)	7 (30)	2.0 (5.0)	1.2 (3.0)
	SP001★161#01	1	0.06 (1.6)	—	2 (3)	22 (100)	7 (30)	2.0 (5.0)	1.2 (3.0)
RISER	SA001★301#01	1	0.11 (2.9)	5 (7)	—	22 (100)	7 (30)	2.0 (5.0)	1.2 (3.0)
	SR001★241#01	1	0.09 (2.4)	3 (5)	—	22 (100)	7 (30)	2.0 (5.0)	1.2 (3.0)
	SR001★201#01	1	0.08 (2.0)	3 (4)	—	22 (100)	7 (30)	2.0 (5.0)	1.2 (3.0)
	SR001★161#01	1	0.06 (1.6)	2 (2)	—	22 (100)	7 (30)	2.0 (5.0)	1.2 (3.0)
LSZH	SE001★301#0E	1	0.11 (2.9)	5 (7)	—	22 (100)	7 (30)	2.0 (5.0)	1.2 (3.0)
	SE001★241#0E	1	0.09 (2.4)	3 (5)	—	22 (100)	7 (30)	2.0 (5.0)	1.2 (3.0)
	SE001★201#0E	1	0.08 (2.0)	3 (4)	—	22 (100)	7 (30)	2.0 (5.0)	1.2 (3.0)

★ Fiber Types – Replace asterisk (★) in AFL number with number in the Fiber Specifications table on previous page.

Outer Jacket Color – Replace hashtag (#) in AFL number with number in the Cable Jacket Color table below.

Cable Jacket Color Options

1 - Blue	6 - White	B - Rose
2 - Orange	7 - Red	C - Aqua
3 - Green	8 - Black	K - Erika Violet (RAL 4003)
4 - Brown	9 - Yellow	
5 - Slate	A - Violet	

Recommended Products

DESCRIPTION	AFL NO.
Xpress Fiber Management® (XFM®) 1RU Patch Panel	Refer to spec sheet for AFL No.

Qualifications

GOVERNING BODY	STANDARD CODE
IEC	61034-1
IEC	61034-2
IEC	60332-1-1
IEC	60332-1-2
IEC	60754-1
IEC	60754-2
Telcordia	GR-409-CORE
RoHS	Compliant to 2002/95/EC
EIA/TIA	568-133

Temperature Specifications

	PLENUM	RISER	LSZH
OPERATION	0°C to +70°C	-20°C to +70°C	0°C to +70°C
STORAGE	-40°C to +75°C	-40°C to +75°C	-40°C to +75°C
INSTALLATION	0°C to +70°C	-20°C to +70°C	0°C to +70°C

Contact AFL for more details.

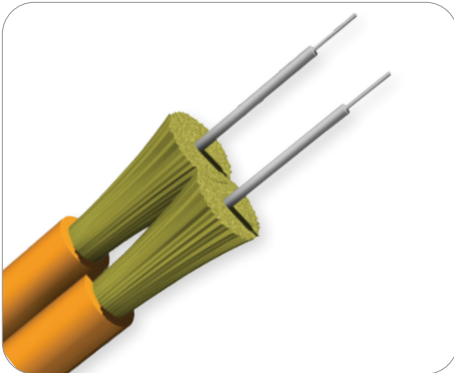

Zipcord, Dual-link and Micro-Dual Cable

Zipcord, DUAL-link and Micro-Dual cables provide links to the future for such protocols as FDDI, 10 Gigabit Ethernet, ATM, and Fibre Channel. AFL offers a broad selection of duplex cordage including Plenum, Riser and LSZH in multiple diameters. LSZH jacketed cables are OFNR listed. One design for global companies that don't want to maintain multiple cable types for varying global standards.

Features

- Flexible, two-fiber design for ease of connections
- Print legend customization
- 12 standard Jacket colors available
- Tight Buffer strippability (easy strip option allows removal of up to 1 meter of 900 μm material without stripping the fiber's 250 μm coating)

Applications

- Communications closet to wall outlet
- Wall outlet to desk
- Connectorized patchcords for interconnect and cross-connect applications
- Easy interface to ESCON®, FDDI, and various other duplex connectors

Cable Components

Zipcord

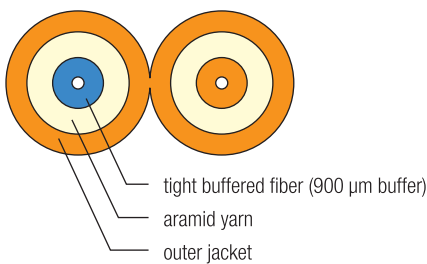

DUAL-Link

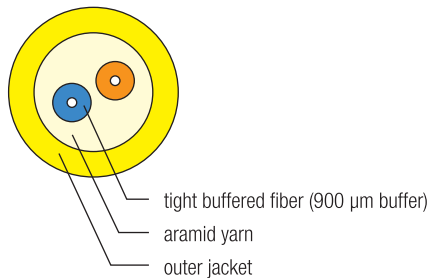

Micro-Dual

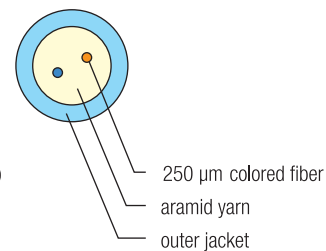

Fiber Specifications

CORE SIZE/FIBER TYPE	ISO/IEC	MAXIMUM ATTENUATION (dB/km)			OVERFILL LAUNCH MIN. BANDWIDTH (MHz•km)		EMB _c (MHz•km)	GIGABIT ETHERNET MAX. LINK DISTANCE (meters)		10 GIGABIT ETHERNET MAX. LINK DISTANCE (meters)	
		850 nm	1300 nm	1550 nm	850 nm	1300 nm		850 nm	1300 nm	850 nm	1300 nm
		(6) 62.5 Giga-Link™ 300	OM1	3.5	1.2	N/A		200	600	N/A	300
(5) 50 Giga-Link™ 600	OM2	3.5	1.5	N/A	500	500	N/A	600	600	82	—
(L) 50 Laser-Link 300	OM3	3.0	1.2	N/A	1,500	500	2,000	1,000	550	300	—
(C) 50 Laser-Link 550	OM4	3.0	1.2	N/A	3,500	500	4,700	1,040	550	550	—
(W) AFL Wideband Multimode	OM5	3.0	1.2	N/A	3,500	500	4,700	1,040	550	550	—
(9) Single-mode (ITU G.652.D/G.657.A1)	OS2	N/A	0.5	0.5	N/A	N/A	N/A	N/A	5,000	N/A	10,000

continued
→

Zipcord, Dual-link and Micro-Dual Cable

Mechanical Data

CABLE TYPE	AFL NO.			FIBER COUNT	NOMINAL DIAMETER inches (mm)	WEIGHT		TENSION		BENDING RADIUS	
	RISER	PLENUM	LSZH			RISER	PLENUM/LSZH	lbs (N)		inches (cm)	
						lbs/1000 ft (kg/km)	lbs/1000 ft (kg/km)	INSTALLATION	LONG TERM	INSTALLATION	LONG TERM
Zipcord	ZA002★301#01	ZP002★301#01	ZE002★301#0E	2	0.11 x 0.22 (2.9 x 6.0)	10 (15)	12 (18)	22 (100)	9 (40)	2.0 (5.0)	1.2 (3.0)
	ZR002★241#01	ZP002★241#01	ZE002★241#0E	2	0.09 x 0.19 (2.4 x 4.8)	7 (10)	9 (14)	22 (100)	9 (40)	2.0 (5.0)	1.2 (3.0)
	ZR002★201#01	ZP002★201#01	ZE002★201#0E	2	0.08 x 0.16 (2.0 x 4.0)	5 (8)	7 (10)	22 (100)	9 (40)	2.0 (5.0)	1.2 (3.0)
	ZR002★161#01	ZP002★161#01	ZE002★161#0E	2	0.06 x 0.12 (1.6 x 3.2)	4 (6)	7 (6)	22 (100)	9 (40)	2.0 (5.0)	1.2 (3.0)
Micro-Dual	DR002★201#0B	DP002★201#0B	DE002★201#0B	2	0.08 (2.0)	3 (5)	5 (7)	22 (100)	9 (40)	1.2 (3.0)	0.78 (2.0)
	—	DP002★161#0B	DE002★161#0B	2	0.06 (1.6)	—	2.7 (1.8)	22 (100)	9 (40)	0.9 (2.3)	0.6 (1.5)
DUAL-Link	DA002★481#01	DP002★481#01	DE002★481#0E	2	0.19 (4.8)	13 (20)	17 (20)	22 (100)	9 (40)	3.1 (7.2)	2.0 (7.2)
	DR002★281#01	DP002★281#01	DE002★281#0E	2	0.11 (2.8)	5 (7)	6 (9)	22 (100)	9 (40)	2.0 (5.0)	1.2 (3.0)
	DR002★241#01	DP002★241#01	DE002★241#0E	2	0.094 (2.4)	3 (5)	5 (7)	22 (100)	9 (40)	2.0 (5.0)	1.2 (3.0)

★ Fiber Types – Replace asterisk (★) in AFL number with number in the Fiber Specifications table on previous page.

Outer Jacket Color – Replace hashtag (#) in AFL number with number in the Cable Jacket Color table below.

Cable Jacket Color Options

1 - Blue	8 - Black
2 - Orange	9 - Yellow
3 - Green	A - Violet
4 - Brown	B - Rose
5 - Slate	C - Aqua
6 - White	K - Erika Violet (RAL 4003)
7 - Red	

Recommended Products

DESCRIPTION	AFL NO.
FASTConnect® Mechanical Connectors	Refer to spec sheet for AFL No.
FUSEConnect® Splice-on Connectors	Refer too spec sheet for AFL No.

Temperature Specifications

	PLENUM	RISER/LSZH
OPERATION	0°C to +70°C	-20°C to +70°C
STORAGE	-40°C to +75°C	-40°C to +75°C
INSTALLATION	0°C to +70°C	-10°C to +70°C

Qualifications

GOVERNING BODY	STANDARD CODE
IEC	61034-1
IEC	61034-2
IEC	60332-1-1
IEC	60332-1-2
IEC	60754-1
IEC	60754-2
Telcordia	GR-409-CORE
RoHS	Compliant to 2002/95/EC
EIA/TIA	568-133

Contact AFL for more details.

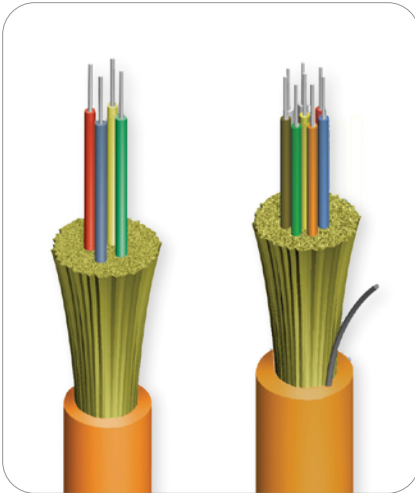

QUAD-link and Circular Premise Cable

QUAD-Link and single unit Circular Premise Cable designs allow for excellent packaging density, flexibility, and ease of routing. Buffered to 900 μm, these cables can be directly terminated into connectors in loaded panels or in communications closets.

Features

- Fiber counts 4-24
- Buffered to 900 μm
- Mixed fiber designs available

Applications

- Connectorized communications cables with both send-and-recv and send-and-recv backup in a single unit
- Routing between communications closets and equipment rooms
- Intra-building backbones

Cable Components

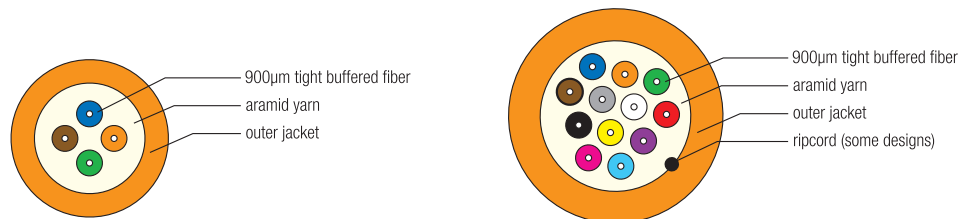

Fiber Specifications

CORE SIZE/FIBER TYPE	ISO/IEC	MAXIMUM ATTENUATION (dB/km)			OVERFILL LAUNCH MIN. BANDWIDTH (MHz•km)		EMB _c (MHz•km)	GIGABIT ETHERNET MAX. LINK DISTANCE (meters)		10 GIGABIT ETHERNET MAX. LINK DISTANCE (meters)	
		850 nm	1300 nm	1550 nm	850 nm	1300 nm		850 nm	1300 nm	850 nm	1300 nm
		(6) 62.5 Giga-Link™ 300	OM1	3.5	1.2	N/A		200	600	N/A	300
(5) 50 Giga-Link™ 600	OM2	3.5	1.5	N/A	500	500	N/A	600	600	82	—
(L) 50 Laser-Link 300	OM3	3.0	1.2	N/A	1,500	500	2,000	1,000	550	300	—
(C) 50 Laser-Link 550	OM4	3.0	1.2	N/A	3,500	500	4,700	1,040	550	550	—
(W) AFL Wideband Multimode	OM5	3.0	1.2	N/A	3,500	500	4,700	1,040	550	550	—
(9) Single-mode (ITU G.652.D/G.657.A1)	OS2	N/A	0.5	0.5	N/A	N/A	N/A	N/A	5,000	N/A	10,000



QUAD-link and Circular Premise Cable

Mechanical Data

CABLE TYPE	AFL NO.		FIBER COUNT	NOMINAL DIAMETER inches (mm)	WEIGHT		TENSION		BENDING RADIUS	
	RISER	PLENUM			RISER	PLENUM	lbs (N)		inches (cm)	
					lbs/1000 ft (kg/km)	lbs/1000 ft (kg/km)	INSTALLATION	LONG TERM	INSTALLATION	LONG TERM
QUAD-Link	UA004★481#01	UP004★481#01	4	0.19 (4.8)	17 (25)	20 (30)	100 (440)	30 (132)	3.0 (7.2)	2.0 (5.0)
CPC	CR006★441#01	CP006★441#01	6	0.17 (4.4)	12 (17)	13 (20)	100 (440)	30 (132)	3.0 (7.2)	2.0 (5.0)
	CR008★481#01	CP008★481#01	8	0.19 (4.8)	13 (19)	17 (25)	100 (440)	30 (132)	3.0 (7.2)	2.0 (5.0)
	CR012★551#01	CP012★551#01	12	0.22 (5.5)	17 (25)	20 (30)	100 (440)	30 (132)	3.5 (8.3)	2.5 (5.5)
	CR018★801#01	CP018★761#01	18	0.32 (8.0)	34 (50)	38 (56)	100 (440)	30 (132)	5.0 (12.0)	3.2 (8.0)
	CR024★841#01	CP024★841#01	24	0.33 (8.4)	41 (61)	46 (69)	150 (660)	45 (198)	5.5 (12.9)	3.5 (8.6)

★ Fiber Types – Replace asterisk (★) in AFL number with number in the Fiber Specifications table on previous page.

Outer Jacket Color – Replace hashtag (#) in AFL number with number in the Cable Jacket Color table below.

Cable Jacket Color Options

1 - Blue	8 - Black
2 - Orange	9 - Yellow
3 - Green	A - Violet
4 - Brown	B - Rose
5 - Slate	C - Aqua
6 - White	K - Erika Violet (RAL 4003)
7 - Red	

Qualifications

GOVERNING BODY	STANDARD CODE
Telcordia	GR-409-CORE
EIA/TIA	568-A
ICEA	
RoHS	2002/95/EC

Temperature Specifications

	PLENUM	RISER
INSTALLATION	0°C to +70°C	-20°C to +70°C
OPERATING	0°C to +70°C	-20°C to +70°C
STORAGE	-40°C to +75°C	-40°C to +75°C

Contact AFL for further details.

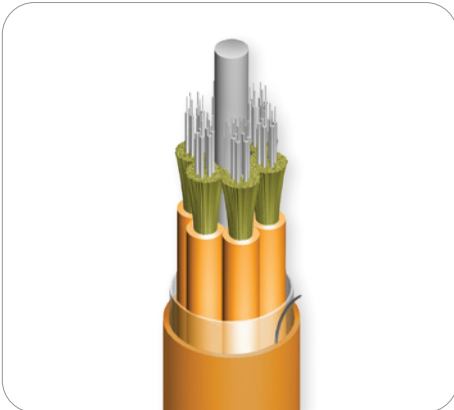

Multi-Unit Circular Premise Cable

Multi-Unit Circular Premise Cables are for use in applications requiring fiber counts between 24 and 144 fibers. Unitized construction allows for ease of fiber identification and rapid installation.

Features

- Available with 24 to 144 fibers
- 12-fiber water-blocked sub-units
- Moisture-resistant, fungus-resistant and UV-resistant outer jacket
- Hybrid constructions also available

Applications

- Headend termination to a fiber "backbone"
- Termination of fiber rack systems
- Multi-floor deployment where select fibers are used at each floor
- Intrabuilding "backbones"

Cable Components

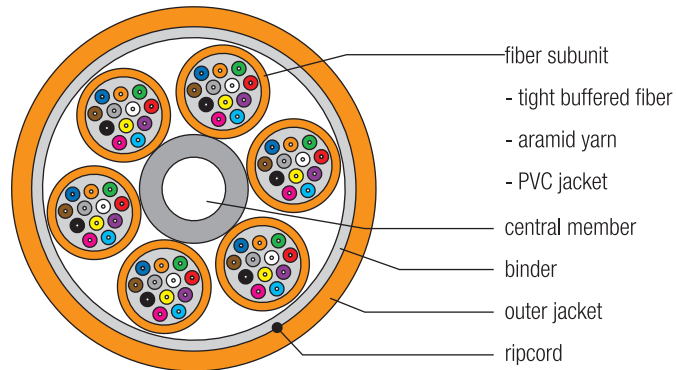

Fiber Specifications

CORE SIZE/FIBER TYPE	ISO/IEC	MAXIMUM ATTENUATION (DB/KM)			OVERFILL LAUNCH MIN. BANDWIDTH (MHz•km)		EMB _c (MHz•km)	GIGABIT ETHERNET MAX. LINK DISTANCE (meters)		10 GIGABIT ETHERNET MAX. LINK DISTANCE (meters)	
		850 nm	1300 nm	1550 nm	850 nm	1300 nm		850 nm	1300 nm	850 nm	1300 nm
(6) 62.5 Giga-Link™ 300	OM1	3.5	1.2	N/A	200	600	N/A	300	550	32	—
(5) 50 Giga-Link™ 600	OM2	3.5	1.5	N/A	500	500	N/A	600	600	82	—
(L) 50 Laser-Link 300	OM3	3.0	1.2	N/A	1,500	500	2,000	1,000	550	300	—
(C) 50 Laser-Link 550	OM4	3.0	1.2	N/A	3,500	500	4,700	1,040	550	550	—
(W) AFL Wideband Multimode	OM5	3.0	1.2	N/A	3,500	500	4,700	1,040	550	550	—
(9) Single-mode (ITU G.652.D/G.657.A1)	OS2	N/A	0.5	0.5	N/A	N/A	N/A	N/A	5,000	N/A	10,000



STOCK ITEM

Multi-Unit Circular Premise Cable

Mechanical Data

CABLE TYPE	AFL NO.		FIBER COUNT	NOMINAL DIAMETER Inches (mm)	WEIGHT		TENSION		BENDING RADIUS	
	RISER	PLENUM			RISER	PLENUM	lbs (N)		inches (cm)	
					lbs/1000ft (kg/km)	lbs/1000ft (kg/km)	INSTALLATION	LONG TERM	INSTALLATION	LONG TERM
CPC with 12 Fiber Subunits	CR024★501##1	CP024★551##1	24	0.30 x 0.52 (7.6 x 13.2)	57 (86)	62 (92)	300 (1320)	150 (660)	5.0 (12.0)	4.0 (10.0)
	CR036★501##1	CP036★551##1	36	0.56 (14.3)	105 (155)	134 (200)	300 (1320)	150 (660)	9.1 (23.1)	6.1 (15.4)
	CR048★501##1	CP048★551##1	48	0.56 (14.3)	105 (155)	134 (200)	300 (1320)	150 (660)	9.1 (23.1)	6.1 (15.4)
	CR060★501##1	CP060★551##1	60	0.68 (17.3)	160 (235)	211 (315)	300 (1320)	150 (660)	10.4 (26.4)	6.9 (17.6)
	CR072★501##1	CP072★551##1	72	0.68 (17.3)	160 (235)	211 (315)	300 (1320)	150 (660)	11.4 (29.0)	7.6 (19.3)
	CR096★501##1	CP096★551##1	96	0.81 (20.6)	280 (410)	295 (440)	300 (1320)	150 (660)	13.5 (34.2)	9.0 (22.8)
	CR144★501##1	CP144★551##1	144	0.92 (23.4)	288 (430)	302 (450)	300 (1320)	150 (660)	15.0 (38.1)	10.0 (25.4)

★ Fiber Types – Replace asterisk (★) in AFL number with number in the Fiber Specifications table on previous page.
 # Outer Jacket Color – Replace hashtag (#) in AFL number with number in the Cable Jacket Color table below.

Cable Jacket Color Options

1 - Blue	8 - Black
2 - Orange	9 - Yellow
3 - Green	A - Violet
4 - Brown	B - Rose
5 - Slate	C - Aqua
6 - White	K - Erika Violet (RAL 4003)
7 - Red	

Qualifications

GOVERNING BODY	STANDARD CODE	COMPONENT
Telcordia	GR-409-CORE	Sub-units
EIA/TIA	568-A	Sub-units
ICEA	S-104-696	Sub-units
NFPA	262	Cable
RoHS	2002/95/EC	Cable

Temperature Specifications

	TEMPERATURE RANGE	
	PLENUM	RISER
INSTALLATION	0°C to +70°C	-20°C to +70°C
OPERATION	0°C to +70°C	-20°C to +70°C
STORAGE	-40°C to +75°C	-40°C to +75°C

Contact AFL for further details.

Fiber Optic Cable

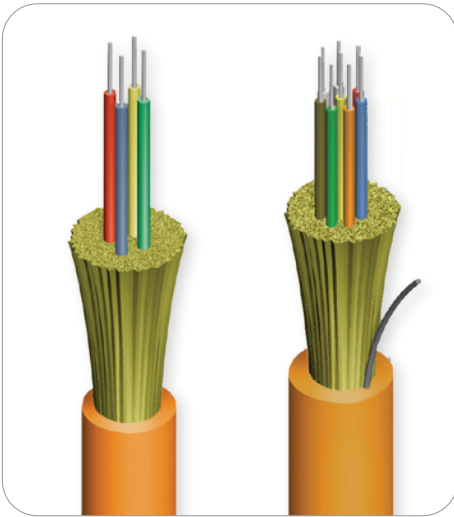

Low Smoke Zero Halogen Distribution Cable

The Low Smoke Zero Halogen (LSZH) Distribution cable family from AFL offers all of the benefits of a traditional 900 µm based optical cable while supporting compliance to stringent international standards for jacket material composition and flame safety. Additionally, AFL's LSZH distribution cable design complies with UL 1666 and UL 1685 standards for OFNR-LS criteria. Circular Premise cable based on 900 µm tight buffer constructions provide the performance and density demanded by today's optical network installation demands. These cable designs support either direct or indirect termination schemes while enabling efficient routing through industry-standard Fiber Management Systems. Cable constructions support the application of Industry-leading multimode fiber as well as single-mode solutions. Both fiber configurations are available in bend-insensitive designs as well.

Features

- 900 µm tight buffer construction
- Fiber counts of 4 to 24 available
- Support either direct or indirect termination schemes
- Mixed fiber designs available

Applications

- Routing between communications closets and equipment rooms
- Data center trunk cabling
- LAN distribution/intrabuilding backbones
- Environments requiring zero-halogen safety features
- Pre-terminated optical assembly

Cable Components

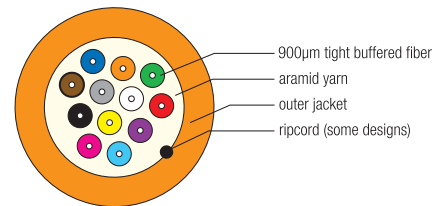
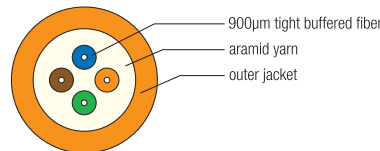

Fiber Specifications

CORE SIZE/FIBER TYPE	ISO/IEC	MAX. ATTENUATION (dB/km)			OVERFILL LAUNCH MIN. BANDWIDTH (MHz•km)		EMBC (MHz•km)	GIGABIT ETHERNET MAX. LINK DISTANCE (meters)		10 GIGABIT ETHERNET MAX. LINK DISTANCE (meters)	
		850 nm	1300 nm	1550 nm	850 nm	1300 nm		850 nm	1300 nm	850 nm	1300 nm
(6) 62.5 Giga-Link™ 300	OM1	3.5	1.2	N/A	200	600	N/A	300	550	32	—
(5) 50 Giga-Link™ 600	OM2	3.5	1.5	N/A	500	500	N/A	600	600	82	—
(L) 50 Laser-Link 300	OM3	3.0	1.2	N/A	1,500	500	2,000	1,000	550	300	—
(C) 50 Laser-Link 550	OM4	3.0	1.2	N/A	3,500	500	4,700	1,040	550	550	—
(W) AFL Wideband Multimode	OM5	3.0	1.2	N/A	3,500	500	4,700	1,040	550	550	—
(9) Single-mode (ITU G.652.D/G.657.A1)	OS2	N/A	0.5	0.5	N/A	N/A	N/A	N/A	5,000	N/A	10,000



Low Smoke Zero Halogen Distribution Cable (cont.)

Mechanical Data

CABLE TYPE	AFL NO.	FIBER COUNT	NOMINAL DIAMETER inches (mm)	WEIGHT lbs/1000 ft (kg/km)	TENSION		BENDING RADIUS	
					lbs (N)		inches (cm)	
	LSZH				INSTALLATION	LONG TERM	INSTALLATION	LONG TERM
QUAD-Link	UE004★481#0E	4	0.189 (4.8)	14 (21)	200 (890)	45 (198)	3.8 (9.6)	1.9 (4.8)
CPC	CE006★521#0E	6	0.205 (5.2)	17 (26)	200 (890)	45 (198)	4.1 (10.4)	2.1 (5.2)
	CE008★541#0E	8	0.213 (5.4)	19 (29)	200 (890)	45 (198)	4.3 (10.8)	2.2 (5.4)
	CE012★601#0E	12	0.236 (6.0)	26 (38)	200 (890)	45 (198)	4.8 (12.0)	2.4 (6.0)
	CE018★761#0E	18	0.299 (7.6)	39 (58)	300 (1320)	90 (396)	6.0 (15.2)	3.0 (7.6)
	CE024★841#0E	24	0.331 (8.4)	50 (75)	300 (1320)	90 (396)	6.5 (16.4)	3.3 (8.4)

★ Fiber Types – Replace asterisk (★) in AFL number with number in the Fiber Specifications table on previous page.

Outer Jacket Color – Replace hashtag (#) in AFL number with number in the Cable Jacket Color table below.

Cable Jacket Color Options

1 - Blue	8 - Black
2 - Orange	9 - Yellow
3 - Green	A - Violet
4 - Brown	B - Rose
5 - Slate	C - Aqua
6 - White	K - Erika Violet (RAL 4003)
7 - Red	

Qualifications

GOVERNING BODY	STANDARD CODE
EIA/TIA	568
Telcordia	GR-409-CORE Issue 2
IEC	60332, 60754, 61034
UL	1666, 1685 (OFNR-LS)
RoHS	2002/95/EC
REACH	SVHC

Temperature Specifications

TEMPERATURE RANGE	
INSTALLATION	-10°C to +60°C
OPERATING	-40°C to +70°C
STORAGE	-40°C to +70°C

Contact AFL for further details.

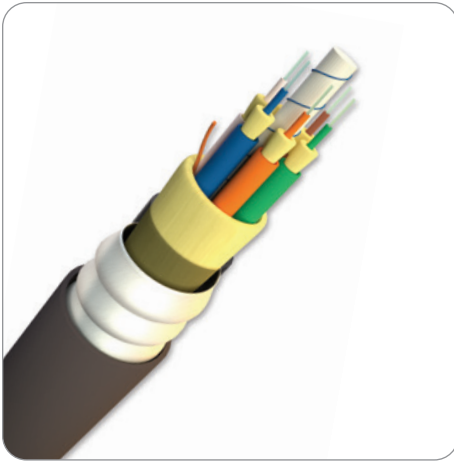

Ruggedized Indoor/Outdoor Breakout Cable

Interlocking Armor Technology

Jacketed aluminum interlocking armor provides the best balance of ruggedness, flexibility, and low weight. Flame-rated armored cables with no outer jacket and flame-rated armored cables with steel interlocking armor are also available. Interlocking armor can also be used with all types of premise cables including Distribution, Indoor/Outdoor Distribution, Breakout and Premise MicroCore®.

Features

- Jacketed aluminum interlocking armor
- Flame-rated armor
- For use with all types of premise cables – distribution, indoor/outdoor distribution, breakout and premise MicroCore

Applications

- Routing inside of buildings where additional ruggedness is required or where increased rodent resistance is required
- Extra protection for fiber optic cables in harsh industrial environments
- Manufacturing plants
- High-density routings in data center applications
- Approved for use in mining applications
- For cables that can be armored, look for the armor shield icon 

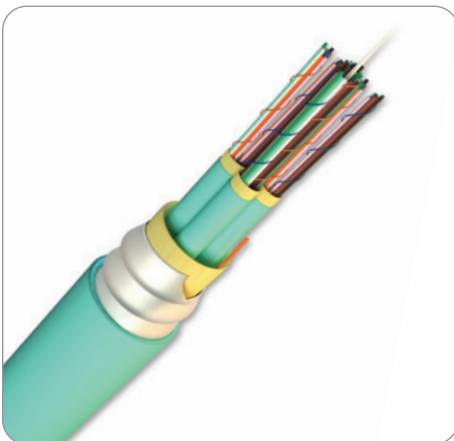

Sub-unitized Premise MicroCore® with SpiderWeb Ribbon® Technology

Cable Components

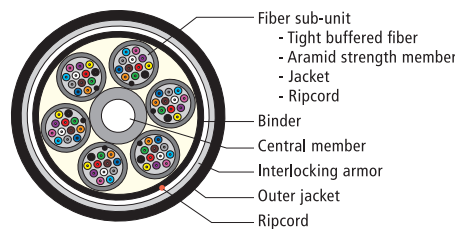

High Fiber Count Circular Premise Cable

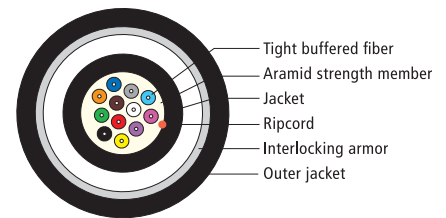

Circular Premise Cable

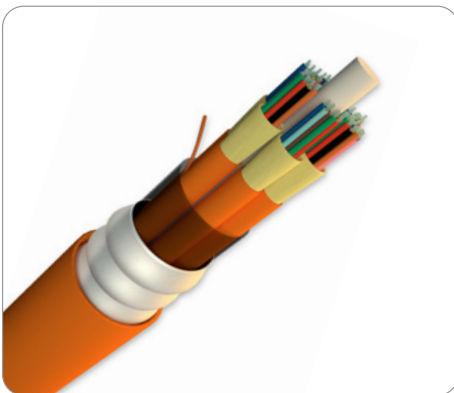

Multi-unit Circular Premise Cable

continued
→

Interlocking Armor Technology

Aluminum Interlocking Armor (AIA) Sizing Chart

MAX CORE OD		OD WITH ARMOR AND JACKET		ARMOR AND JACKET WEIGHT (ADD TO CORE CABLE)						BEND RADIUS INCH (MM)			
				PLENUM PVC (OFCP) AIAP		RISER PVC (OFCR) AIAR		LSZH AIAL		SHORT TERM		LONG TERM	
INCH	MM	INCH	MM	LBS/1000FT	KG/KM	LBS/1000FT	KG/KM	LBS/1000FT	KG/KM	INCH	CM	INCH	CM
0.17	4.4	0.47	11.9	67	100	60	90	67	100	7	18	5	12
0.22	5.6	0.52	13.3	77	115	70	105	77	115	8	20	5	13.5
0.26	6.6	0.56	14.3	87	130	77	115	87	130	8	21.5	6	14.5
0.33	8.4	0.62	15.9	97	145	87	130	97	145	9	24	6	16
0.37	9.4	0.68	17.3	107	160	97	145	107	160	10	26	7	17.5
0.42	10.7	0.74	18.7	121	180	107	160	117	175	11	28	7	18.5
0.46	11.7	0.77	19.7	127	190	114	170	124	185	12	29.5	8	19.5
0.52	13.1	0.83	21.1	138	205	124	185	138	205	12	31.5	8	21
0.56	14.2	0.87	22.1	148	220	134	200	144	215	13	33	9	22
0.63	16.1	0.96	24.3	161	240	144	215	161	240	14	36.5	10	24.5
0.69	17.4	1.02	25.9	171	255	154	230	168	250	15	39	10	26
0.74	18.7	1.07	27.1	185	275	164	245	181	270	16	40.5	11	27
0.78	19.8	1.12	28.4	191	285	171	255	188	280	17	42.5	11	28.5
0.83	21.1	1.17	29.7	201	300	181	270	198	295	18	44.5	12	29.5
0.88	22.3	1.22	31.0	211	315	191	285	211	315	18	46.5	12	31
0.92	23.3	1.27	32.2	221	330	198	295	218	325	19	48.5	13	32
0.96	24.4	1.30	33.0	231	345	208	310	228	340	19	49.5	13	33
1.04	26.3	1.39	35.3	242	360	218	325	242	360	21	53	14	35.5

Qualifications

GOVERNING BODY	STANDARD CODE	COMPONENT
Telcordia	GR-20-CORE GR-409-CORE	Water-Blocked Cabled Buffer Tube Core Sub-units
EIA/TIA	598-A	Sub-units
NFPA		Cable Armor
ICEA	S-104-696	Sub-units
MSHA*		
RoHS	2002/95/EC	Cable

* Only with MSHA-approved base cables

Temperature Specifications

	PLENUM	RISER
INSTALLATION	0°C to +70°C	-10°C to +70°C
OPERATION	0°C to +70°C	-10°C to +70°C
STORAGE	-40°C to +75°C	-40°C to +75°C

Contact AFL for further details.

Premise Cable

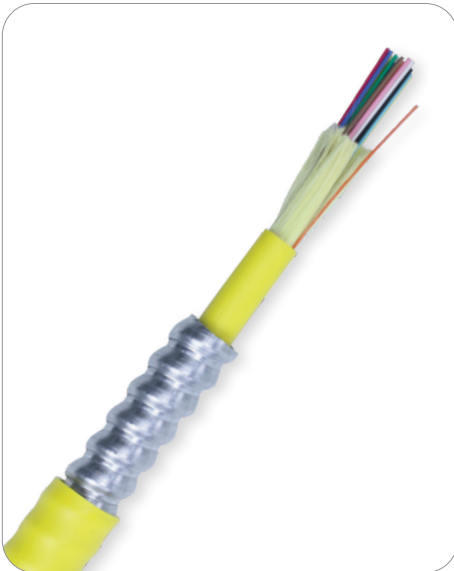

Armored Tight Buffered Circular Premise Cable

Armored Tight Buffered CPC Cables incorporate 4 to 144 fiber count CPC cables in a jacketed, aluminum interlocking armor. Jacketed aluminum interlocking armor provides the best balance of ruggedness, flexibility, and low weight. Flame rated armored cables with no outer jacket and flame rated armored cables with steel interlocking armor are also available. Interlocking armor can also be used with other types of trunk cables, including Indoor/Outdoor Distribution, Breakout and Premise MicroCore®.

Features

- Fiber counts 4-144
- Aluminum interlocking armor

Applications

- Routing inside of buildings where additional ruggedness is required or where increased rodent resistance is required
- Extra protection for fiber optic cables in harsh industrial environments
- Manufacturing plants
- High-density routings in data center applications

Cable Components

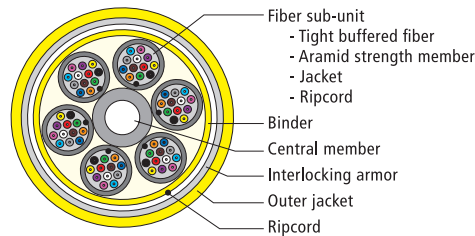

High Fiber Count Circular Premise Cable

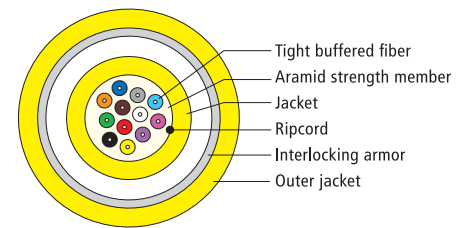

Circular Premise Cable

Fiber Specifications

CORE SIZE/FIBER TYPE	ISO/IEC	MAXIMUM ATTENUATION (dB/km)			OVERFILL LAUNCH MIN. BANDWIDTH (MHz•km)		EMB _c (MHz•km)	GIGABIT ETHERNET MAX. LINK DISTANCE (meters)		10 GIGABIT ETHERNET MAX. LINK DISTANCE (meters)	
		850 nm	1300 nm	1550 nm	850 nm	1300 nm		850 nm	1300 nm	850 nm	1300 nm
(6) 62.5 Giga-Link™ 300	OM1	3.5	1.2	N/A	200	600	N/A	300	550	32	—
(5) 50 Giga-Link™ 600	OM2	3.5	1.5	N/A	500	500	N/A	600	600	82	—
(L) 50 Laser-Link 300	OM3	3.0	1.2	N/A	1,500	500	2,000	1,000	550	300	—
(C) 50 Laser-Link 550	OM4	3.0	1.2	N/A	3,500	500	4,700	1,040	550	550	—
(W) AFL Wideband Multimode	OM5	3.0	1.2	N/A	3,500	500	4,700	1,040	550	550	—
(9) Single-mode (ITU G.652.D/G.657.A1)	OS2	N/A	0.5	0.5	N/A	N/A	N/A	N/A	5,000	N/A	10,000



Armored Tight Buffered Circular Premise Cable

Mechanical Data

AFL NO.		FIBER COUNT	NOMINAL DIAMETER inches (mm)	WEIGHT		TENSION				BENDING RADIUS	
RISER	PLENUM			RISER	PLENUM	RISER		PLENUM		INSTALLATION	LONG TERM
				lbs/1000 ft (kg/km)		INSTALLATION	LONG TERM	INSTALLATION	LONG TERM		
						lbs (N)	lbs (N)	lbs (N)	lbs (N)	inches (cm)	inches (cm)
UA004★481#01-AIAR	UP004★481#01-AIAP	4	0.46 (11.8)	79 (117)	89 (132)	150 (660)	45 (198)	100 (440)	30 (132)	7.0 (17.7)	5.0 (12.7)
CR006★441#01-AIAR	CP006★441#01-AIAP	6	0.46 (11.8)	74 (109)	82 (122)	150 (660)	45 (198)	100 (440)	30 (132)	7.0 (17.7)	4.8 (12.2)
CR012★551#01-AIAR	CP012★551#01-AIAP	12	0.51 (13.0)	79 (117)	89 (132)	150 (660)	45 (198)	100 (440)	30 (132)	7.0 (17.7)	5.0 (12.7)
CR024★891#01-AIAR	CP024★841#01-AIAP	24	0.62 (15.7)	129 (193)	144 (215)	300 (1320)	90 (396)	150 (660)	45 (198)	9.3 (23.6)	5.3 (13.4)
CR036★501##1-AIAR	CP036★551##1-AIAP	36	0.94 (24)	250 (370)	294 (439)	300 (1320)	90 (396)	150 (660)	45 (198)	14.2 (36.0)	9.4 (24.0)
CR048★501##1-AIAR	CP048★551##1-AIAP	48	0.94 (24)	250 (370)	294 (439)	300 (1320)	90 (396)	150 (660)	45 (198)	14.2 (36.0)	9.4 (24.0)
CR072★501##1-AIAR	CP072★551##1-AIAP	72	1.10 (27.9)	314 (465)	401 (597)	300 (1320)	90 (396)	150 (660)	45 (198)	16.5 (41.9)	11.0 (27.9)
CR096★501##1-AIAR	CP096★551##1-AIAP	96	1.21 (30.7)	460 (680)	507 (755)	300 (1320)	90 (396)	150 (660)	45 (198)	18.1 (46.1)	12.1 (30.7)
CR144★501##1-AIAR	CP144★551##1-AIAP	144	1.37 (34.8)	460 (680)	534 (796)	300 (1320)	90 (396)	150 (660)	45 (198)	19.8 (50.3)	13.2 (33.5)

★ Fiber Types – Replace asterisk (★) in AFL number with number in the Fiber Specifications table on previous page.

Outer Jacket Color – Replace hashtag (#) in AFL number with number in the Cable Jacket Color table below.

Cable Jacket Color Options

1 - Blue	8 - Black
2 - Orange	9 - Yellow
3 - Green	A - Violet
4 - Brown	B - Rose
5 - Slate	C - Aqua
6 - White	K - Erika Violet (RAL 4003)
7 - Red	

Qualifications

GOVERNING BODY	STANDARD CODE
MSHA	
NFPA	
RoHS	2002/95/EC
EIA/TIA	
ICEA	
ISO	
ITU	
Telcordia	GR-409-CORE

Temperature Specifications

	PLENUM	RISER
INSTALLATION	0°C to +70°C	-10°C to +70°C
OPERATING	0°C to +70°C	-10°C to +70°C
STORAGE	-40°C to +75°C	-40°C to +75°C

Contact AFL for further details.

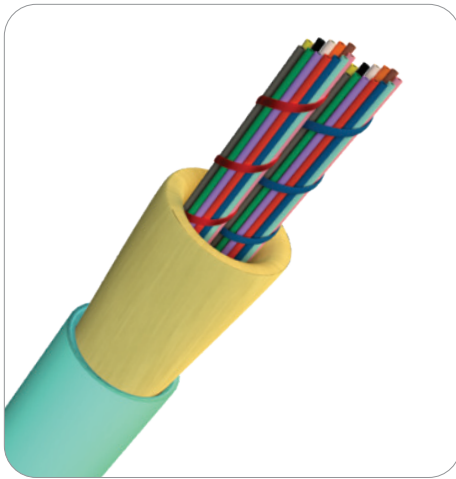

Interconnect Premise MicroCore® Cable

Interconnect Premise MicroCore cables are designed for MTP terminations and meet the interconnect standards of Telcordia® GR-409. To minimize the cable's diameter, multiple colored 250 μm fibers and aramid strands are packaged in a PVC or LSZH jacket. Simplex and Zipcord designs are available in a variety of fiber counts.

Features

- 8 to 72 fibers
- 2.0 mm or 3.0 mm Outer Diameter for Round Boot 12-fiber MTP Cables
- 3.0 mm or 3.8 mm Outer Diameter for Round Boot 24-fiber MTP Cables
- 4.0 mm Outer Diameter for Round Boot 48-count MTP Cables

Applications

- Building Interconnections
- Data Centers and Central Offices
- Anywhere MTP connections can be used
- High-density Interconnects
- 40 Gbit and 100 Gbit Ethernet Architecture

Cable Components

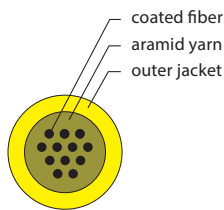

12 Fiber Simplex

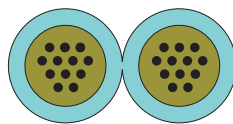

24 Fiber Zipcord
(3.0 mm only)

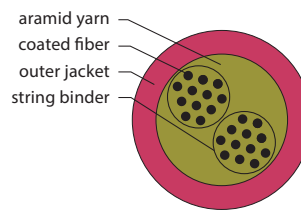

24 Fiber Simplex

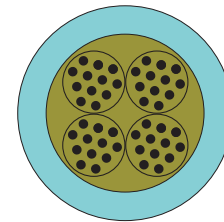

48 Fiber Simplex

Fiber Specifications

CORE SIZE/FIBER TYPE	ISO/IEC	MAXIMUM ATTENUATION (dB/km)			OVERFILL LAUNCH MIN. BANDWIDTH (MHz•km)		EMB _c (MHz•km)	GIGABIT ETHERNET MAX. LINK DISTANCE (meters)		10 GIGABIT ETHERNET MAX. LINK DISTANCE (meters)	
		850 nm	1300 nm	1550 nm	850 nm	1300 nm		850 nm	1300 nm	850 nm	1300 nm
(6) 62.5 Giga-Link™ 300	OM1	3.5	1.2	N/A	200	600	N/A	300	550	32	—
(5) 50 Giga-Link™ 600	OM2	3.5	1.5	N/A	500	500	N/A	600	600	82	—
(L) 50 Laser-Link 300	OM3	3.0	1.2	N/A	1,500	500	2,000	1,000	550	300	—
(C) 50 Laser-Link 550	OM4	3.0	1.2	N/A	3,500	500	4,700	1,040	550	550	—
(W) AFL Wideband Multimode	OM5	3.0	1.2	N/A	3,500	500	4,700	1,040	550	550	—
(9) Single-mode (ITU G.652.D/G.657.A1)	OS2	N/A	0.5	0.5	N/A	N/A	N/A	N/A	5,000	N/A	10,000

*Other fiber types available (All ITU G.657 grade SMF available)

continued
→

Interconnect Premise MicroCore® Cable

Mechanical Data

CABLE TYPE	PLENUM	LSZH	FIBER COUNT	NOMINAL DIAMETER	WEIGHT	TENSION lbs (N)		BENDING RADIUS inches (cm)	
	AFL NO.			inches (mm)	lbs/1000 ft (kg/km)	INSTALLATION	LONG TERM	INSTALLATION	LONG TERM
	SP/ZP	SE/ZE							
SINGLE SMALL FORM	SP008◆201#0B	SE008◆201#0B	8	0.08 (2.0)	2.6 (4.0)	22 (98)	7 (30)	1.2 (3.0)	0.8 (2.0)
	SP012◆201#0B	SE012◆201#0B	12	0.08 (2.0)	2.6 (4.0)	22 (98)	7 (30)	1.2 (3.0)	0.8 (2.0)
	SP016◆301#0B	SE016◆301#0B	16	0.12 (3.0)	5.3 (7.9)	22 (98)	7 (30)	1.8 (4.5)	1.2 (3.0)
	SP024◆301#0B	SE024◆301#0B	24	0.12 (3.0)	5.3 (7.9)	22 (98)	7 (30)	1.8 (4.5)	1.2 (3.0)
	SP032◆381#0B	SE032◆381#0B	32	0.15 (3.8)	9.4 (14.0)	22 (98)	7 (30)	2.2 (5.7)	1.5 (3.8)
	SP048◆381#0B	SE048◆381#0B	48	0.15 (3.8)	9.4 (14.0)	22 (98)	7 (30)	2.2 (5.7)	1.5 (3.8)
SIMPLEX	SP008◆301#0B	SE008◆301#0B	8	0.12 (3.0)	5.3 (7.9)	50 (220)	17 (75)	1.8 (4.5)	1.2 (3.0)
	SP012◆301#0B	SE012◆301#0B	12	0.12 (3.0)	5.3 (7.9)	50 (220)	17 (75)	1.8 (4.5)	1.2 (3.0)
	SP024◆381#0B	SE024◆381#0B	24	0.15 (3.8)	10.1 (15.0)	75 (330)	25 (110)	2.2 (5.7)	1.5 (3.8)
	SP048◆401#0B	SE048◆401#0B	48	0.16 (4.0)	9.4 (14.0)	50 (220)	17 (75)	2.4 (6.0)	1.6 (4.0)
	SP048◆481#0B	SE048◆481#0B	48	0.19 (4.8)	14.1 (21.0)	75 (330)	25 (110)	2.8 (7.2)	1.9 (4.8)
	SP064◆451#0B	SE064◆451#0B	64	0.18 (4.5)	13.4 (20.0)	50 (220)	17 (75)	2.7 (6.8)	1.8 (4.5)
	SP072◆481#0B	SE072◆481#0B	72	0.19 (4.8)	16.1 (24.0)	50 (220)	17 (75)	2.8 (7.2)	1.9 (4.8)
ZIPCORD	ZP024◆301#0B	ZE024◆301#0B	24	0.12 (3.0)	12.4 (18.4)	100 (445)	33 (147)	1.8 (4.5)	1.2 (3.0)

◆ Fiber Types – Replace diamond (◆) in AFL No. with number in the Fiber Specifications table on previous page.

Outer Jacket Color – Replace hashtag (#) in AFL No. with number in the Cable Jacket Color table below.

16 unique colors available for fibers in 16 fiber subunit: Blue, Orange, Green, Brown, Slate, White, Red, Black, Yellow, Violet, Rose, Aqua, Olive, Magenta, Tan, Lime.

Cable Jacket Color Options

1 - Blue	8 - Black
2 - Orange (OM1 and OM2)	9 - Yellow (SM)
3 - Green	A - Violet
4 - Brown	B - Rose
5 - Slate	C - Aqua (OM3 and OM4)
6 - White	K - Erika Violet (OM4)
7 - Red	L - Lime (Pending for OM5)

Qualifications

GOVERNING BODY	STANDARD CODE
NFPA	262
IEC	60332
IEC	60754
IEC	61034
Telcordia	GR-409-CORE
RoHS	Compliant to 2002/95/EC

Temperature Specifications

TEMPERATURE RANGE	
OPERATION	0°C to +70°C
STORAGE	-40°C to +75°C
INSTALLATION	0°C to +70°C

Contact AFL for cable designs.



Interconnect Premise MicroCore® Cable with SpiderWeb Ribbon® (SWR®) Technology

Interconnect Premise MicroCore cables with SWR are designed for MTP terminations and meet the interconnect standards of Telcordia® GR-409. To minimize the cable's diameter, SWR and aramid strands are packaged in a high performance PVC or LSZH jacket. Fiber counts of 12 and 24 are available. Both Simplex and Zipcord designs are available.

SWR is a bonded fiber design allowing for either a highly efficient ribbonizing application or for individual fiber breakouts. This flexibility allows for the application of a single cable design to cover a diverse set of applications. High-density round designs allow for the most efficient use of space and materials, resulting in a cost-effective solution.

Features

- 3.0 mm Outer Diameter for Round Boot 12-fiber MTP Cables
- 3.0 mm or 3.8 mm Outer Diameter for Round Boot 24-fiber MTP Cables
- Exceptional skew performance

Applications

- Building Interconnections
- Data Centers and Central Offices
- Anywhere MTP connections can be used
- High-density Interconnects
- 40 Gbit and 100 Gbit Ethernet Architecture

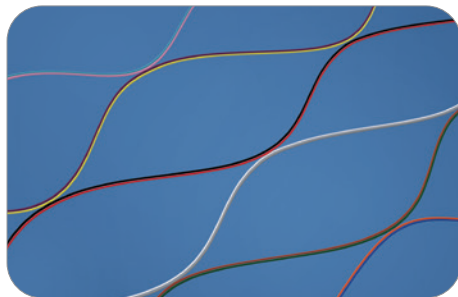

SpiderWeb Ribbon Technology

Cable Components

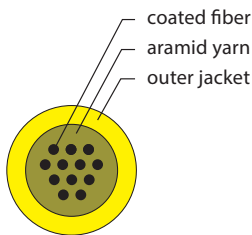

12 Fiber Simplex

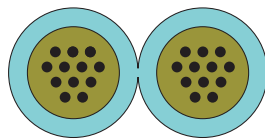

24 Fiber Zipcord
(3.0 mm only)

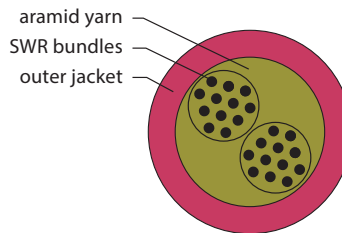

24 Fiber Simplex

SWR Fiber Specifications

CORE SIZE/FIBER TYPE	ISO	MAX. ATTENUATION (dB/km)			OVERFILL LAUNCH MIN. BANDWIDTH (MHz•km)		EMBC (MHz•km)	GIGABIT ETHERNET MAX. LINK DISTANCE (meters)		10 GIGABIT ETHERNET MAX. LINK DISTANCE (meters)	
		850 nm	1300 nm	1550 nm	850 nm	1300 nm		850 nm	1300 nm	850 nm	1300 nm
		(P) AFL Bend-Insensitive Single-mode (ITU G.652.D/G.657.A1)	OS2	N/A	0.5	0.5		N/A	N/A	N/A	5,000

continued
→

Interconnect Premise MicroCore® Cable with SpiderWeb Ribbon® (SWR®) Technology

Mechanical Data

CABLE TYPE	FIBER COUNT	NOMINAL DIAMETER	WEIGHT	TENSION lbs (N)		BENDING RADIUS inches (cm)	
		inches (mm)	lbs/1000 ft (kg/km)	INSTALLATION	LONG TERM	INSTALLATION	LONG TERM
SINGLE SMALL FORM	24	0.12 (3.0)	5.3 (7.9)	22 (98)	7 (30)	1.8 (4.5)	1.2 (3.0)
SIMPLEX	12	0.12 (3.0)	5.3 (7.9)	50 (220)	17 (75)	1.8 (4.5)	1.2 (3.0)
	24	0.15 (3.8)	10.1 (15.0)	75 (330)	25 (110)	2.2 (5.7)	1.5 (3.8)
ZIPCORD	24	0.12 (3.0)	12.4 (18.4)	100 (445)	33 (147)	1.8 (4.5)	1.2 (3.0)

Ordering Information

CABLE TYPE	FIBER COUNT	AFL NO.	
		SINGLE-MODE	
		PLENUM	LSZH
SINGLE SMALL FORM	24	SP024P301#0R	SE024P301#0R
SIMPLEX	12	SP012P301#0R	SE012P301#0R
	24	SP024P381#0R	SE024P381#0R
ZIPCORD	24	ZP024P301#0R	ZE024P301#0R

Replace # with number corresponding to desired jacket color from Cable Jacket Color Options table below.

Cable Jacket Color Options

1 - Blue	6 - White	B - Rose
2 - Orange	7 - Red	C - Aqua (OM3 and OM4)
3 - Green	8 - Black	K - Erika Violet (OM4)
4 - Brown	9 - Yellow (SM)	L - Lime
5 - Slate	A - Violet	

Qualifications

GOVERNING BODY	STANDARD CODE	COMPONENT
NFPA	262 (ONFP)	Jacket
IEC	60332, 60754, 61034	LSZH/ONFR-LS Jacket
Telcordia	GR-409-CORE	Jacket
RoHS	2002/95/EC	Jacket

Temperature Specifications

TEMPERATURE RANGE	
INSTALLATION	0°C to +70°C
OPERATING	0°C to +70°C
STORAGE	-40°C to +75°C

Contact AFL for further details.



Ruggedized MicroCore® Cable

AFL Ruggedized MicroCore is the next generation of maximizing fiber density in AFL's line of high density data center cables. Ruggedized MicroCore is an industry leading alternative to a traditional inside plant central loose tube ribbon cable. Ruggedized MicroCore with bare fiber eliminates concerns associated with edge fiber stresses due to preferential bend of encapsulated ribbons. These cables consist of an OFNP/FT6 (NFPA 262) or LSZH (including ONFR-LS/FT4) flame-rated outer jacket with an installation tension rating of 150 lbs. qualified to meet and exceed the requirements of the latest Telcordia GR-409-CORE inside plant cabling requirements.

Features

- Fiber counts 8 to 72
- Plenum or LSZH Riser options
- Flame rated
- Installation tension rating of 150 lbs.

Applications

- Headend termination to a fiber "backbone"
- Termination of fiber rack systems
- Intra-building "backbones"
- MTP/MPO or MTP to breakout terminations

Cable Components

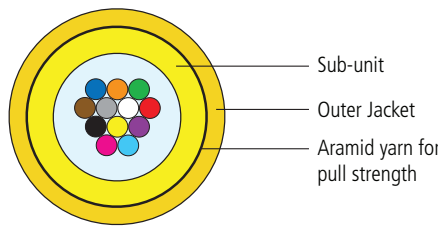

Ruggedized 12 fiber

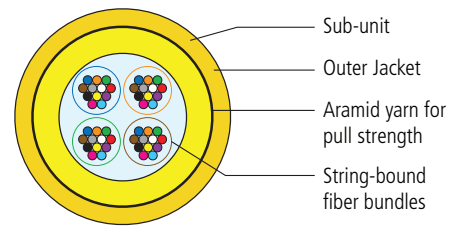

Ruggedized 48 fiber

Fiber Specifications

CORE SIZE/FIBER TYPE	ISO/IEC	MAXIMUM ATTENUATION (dB/km)			OVERFILL LAUNCH MIN. BANDWIDTH (MHz•km)		EMBC (MHz•km)	GIGABIT ETHERNET MAX. LINK DISTANCE (meters)		10 GIGABIT ETHERNET MAX. LINK DISTANCE (meters)	
		850 nm	1300 nm	1550 nm	850 nm	1300 nm		850 nm	1300 nm	850 nm	1300 nm
(6) 62.5 Giga-Link™ 300	OM1	3.5	1.2	N/A	200	600	N/A	300	550	32	—
(5) 50 Giga-Link™ 600	OM2	3.5	1.5	N/A	500	500	N/A	600	600	82	—
(L) 50 Laser-Link 300	OM3	3.0	1.2	N/A	1,500	500	2,000	1,000	550	300	—
(C) 50 Laser-Link 550	OM4	3.0	1.2	N/A	3,500	500	4,700	1,040	550	550	—
(W) AFL Wideband Multimode	OM5	3.0	1.2	N/A	3,500	500	4,700	1,040	550	550	—
(9) Single-mode (ITU G.652.D/G.657.A1)	OS2	N/A	0.5	0.5	N/A	N/A	N/A	N/A	5,000	N/A	N/A



Ruggedized MicroCore® Cable

Ordering Information

NO. OF FIBERS	AFL NO.		NOMINAL DIAMETER inches (mm)	NOMINAL SUB-UNIT DIAMETER inches (mm)	WEIGHT lbs/1000 ft (kg/km)	TENSION lbs (N)		BENDING RADIUS inches (cm)	
	PLENUM	LSZH				INSTALLATION	LONG TERM	INSTALLATION	LONG TERM
8	RQ008★301##B	RE008★301##B	0.19 (4.8)	0.12 (3.0)	15 (22)	150 (660)	45 (200)	2.9 (7.2)	1.9 (4.8)
12	RQ012★301##B	RE012★301##B	0.19 (4.8)	0.12 (3.0)	15 (22)	150 (660)	45 (200)	2.9 (7.2)	1.9 (4.8)
16	RQ016★301##B	RE016★301##B	0.19 (4.8)	0.12 (3.0)	15 (22)	150 (660)	45 (200)	2.9 (7.2)	1.9 (4.8)
24	RQ024★301##B	RE024★301##B	0.19 (4.8)	0.12 (3.0)	15 (22)	150 (660)	45 (200)	2.9 (7.2)	1.9 (4.8)
32	RQ032★381##B	RE032★381##B	0.22 (5.6)	0.15 (3.8)	19 (29)	150 (660)	45 (200)	3.3 (8.4)	2.2 (5.6)
36	RQ036★381##B	RE036★381##B	0.22 (5.6)	0.15 (3.8)	21 (31)	150 (660)	45 (200)	3.3 (8.4)	2.2 (5.6)
48	RQ048★401##B	RE048★401##B	0.22 (5.6)	0.16 (4.0)	22 (32)	150 (660)	45 (200)	3.3 (8.4)	2.2 (5.6)
64	RQ064★451##B	RE064★451##B	0.24 (6.2)	0.18 (4.5)	28 (42)	150 (660)	45 (200)	3.6 (9.3)	2.4 (6.2)
72	RQ072★451##B	RE072★481##B	0.25 (6.4)	0.19 (4.8)	30 (45)	150 (660)	45 (200)	3.8 (9.6)	2.5 (6.4)

★ Fiber Types – Replace asterisk (★) in AFL number with number in the Fiber Specifications table on previous page.
 # Outer Jacket Color – Replace hashtag (#) in AFL number with number in the Cable Jacket Color table below.

Cable Jacket Color Options

1 - Blue	8 - Black
2 - Orange	9 - Yellow (SM)
3 - Green	A - Violet
4 - Brown	B - Rose
5 - Slate	C - Aqua (OM3 and OM4)
6 - White	K - Erika Violet (OM4)
7 - Red	L - Lime

Qualifications

GOVERNING BODY	STANDARD CODE	COMPONENT
NFPA	262 (ONFP) / FT6	Jacket
IEC	60332, 60754, 61034	LSZH/ONFR-LS Jacket
Telcordia	GR-409-CORE	Jacket
EIA/TIA	568	Jacket
ICEA		Jacket
RoHS	REACH	Jacket

Contact AFL for further details.

Temperature Specifications

	TEMPERATURE RANGE	
	PLENUM	LSZH
INSTALLATION	- 0°C to +60°C	- 0°C to +60°C
OPERATION	- 0°C to +70°C	- 20°C to +70°C
STORAGE	- 40°C to +70°C	- 40°C to +70°C

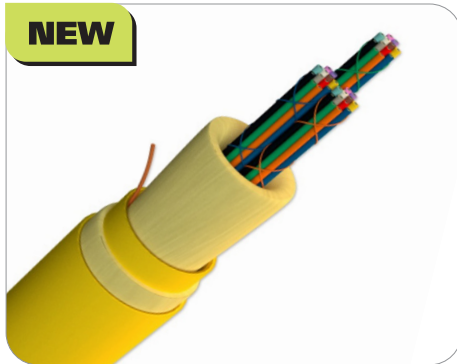

Ruggedized MicroCore® Cable with SpiderWeb Ribbon® Technology

AFL Ruggedized MicroCore with SpiderWeb Ribbon (SWR®) Technology is the next generation of maximizing fiber density in AFL's line of high density data center cables. Ruggedized MicroCore is an industry-leading alternative to a traditional inside plant central loose tube ribbon cable. SWR technology eliminates concerns associated with edge fiber stresses due to preferential bend of encapsulated ribbons. These cables consists of an OFNP/FT6 (NFPA 262) or LSZH (including ONFR-LS/FT4), flame-rated outer jacket with an installation tension rating of 150 lbs. qualified to meet and exceed the requirements of the latest Telcordia GR-409-CORE inside plant cabling requirements.

Features

- SpiderWeb Ribbon (SWR) optical fiber technology
- Fiber counts 12 to 144
- Plenum or LSZH Riser options
- Flame-rated jacket
- All aramid tensile strength members around core cable for ease of attaching pulling-eye; aramid within core for use with MT termination
- Installation tension rating of 150 lbs.

Applications

- Headend termination to a fiber "backbone"
- Termination of fiber rack systems
- Intra-building "backbones"
- MTP/MPO or MTP to breakout terminations

Cable Components

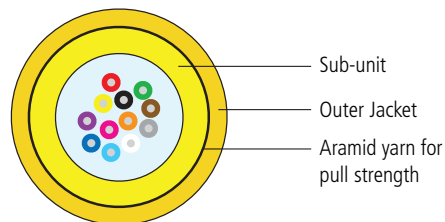

SWR Ruggedized 12 fiber

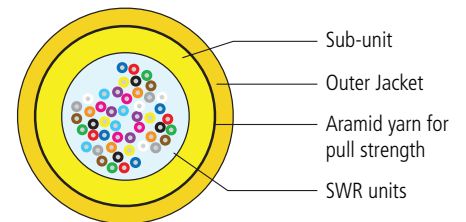

SWR Ruggedized 48 fiber

SWR Fiber Specifications

CORE SIZE/FIBER TYPE	ISO/IEC	MAXIMUM ATTENUATION (dB/km)			OVERFILL LAUNCH MIN. BANDWIDTH (MHz•km)		EMB _c (MHz•km)	GIGABIT ETHERNET MAX. LINK DISTANCE (meters)		10 GIGABIT ETHERNET MAX. LINK DISTANCE (meters)	
		850 nm	1300 nm	1550 nm	850 nm	1300 nm		850 nm	1300 nm	850 nm	1300 nm
(P) AFL Bend-Insensitive Single-mode (ITU G.652.D/G.657.A1)	OS2	N/A	0.5	0.5	N/A	N/A	N/A	N/A	5,000	N/A	10,000



Ruggedized MicroCore® Cable with SpiderWeb® Ribbon Technology

Ordering Information

NO. OF FIBERS	AFL NO.	
	SINGLE-MODE	
	PLENUM	LSZH
12	RQ012P301##R	RE012P301##R
24	RQ024P301##R	RE024P301##R
36	RQ036P381##R	RE036P381##R
48	RQ048P401##R	RE048P401##R
72	RQ072P451##R	RE072P481##R
96	RQ096P581##R	RE096P581##R
108	RQ108P621##R	RE108P621##R
120	RQ120P721##R	RE120P721##R
144	RQ144P721##R	RE144P721##R

Outer Jacket Color – Replace hashtag (#) in AFL number with number in the Cable Jacket Color table below.

Mechanical Data

NO. OF FIBERS	NOMINAL DIAMETER inches (mm)	NOMINAL SUB-UNIT DIAMETER inches (mm)	WEIGHT lbs/1000 ft (kg/km)	TENSION lbs (N)		BENDING RADIUS inches (cm)	
				INSTALLATION	LONG TERM	INSTALLATION	LONG TERM
12	0.19 (4.8)	0.12 (3.0)	15 (22)	150 (660)	45 (200)	2.9 (7.2)	1.9 (4.8)
24	0.19 (4.8)	0.12 (3.0)	15 (22)	150 (660)	45 (200)	2.9 (7.2)	1.9 (4.8)
36	0.22 (5.6)	0.15 (3.8)	21 (31)	150 (660)	45 (200)	3.3 (8.4)	2.2 (5.6)
48	0.22 (5.6)	0.15 (3.8)	22 (32)	150 (660)	45 (200)	3.3 (8.4)	2.2 (5.6)
72	0.25 (6.4)	0.19 (4.8)	30 (45)	150 (660)	45 (200)	3.8 (9.6)	2.5 (6.4)
96	0.31 (7.8)	0.23 (5.8)	44 (65)	150 (660)	45 (200)	4.7 (11.7)	3.1 (7.8)
108	0.35 (9.0)	0.24 (6.2)	58 (86)	150 (660)	45 (200)	5.3 (13.5)	3.5 (9.0)
120	0.39 (10.0)	0.28 (7.2)	73 (109)	150 (660)	45 (200)	5.9 (15.0)	3.9 (10.0)
144	0.39 (10.0)	0.28 (7.2)	74 (110)	150 (660)	45 (200)	5.9 (15.0)	3.9 (10.0)

Cable Jacket Color Options

1 - Blue	8 - Black
2 - Orange	9 - Yellow
3 - Green	A - Violet
4 - Brown	B - Rose
5 - Slate	C - Aqua
6 - White	K - Erika Violet (RAL 4003)
7 - Red	

Qualifications

GOVERNING BODY	STANDARD CODE	COMPONENT
NFPA	262 (ONFP) / FT6	Plenum Jacket
IEC	60332, 60754, 61034	LSZH/ONFR-LS Jacket
Telcordia	GR-409-CORE	Jacket
EIA/TIA	568	Jacket
ICEA		Jacket
RoHS	REACH	Jacket

Temperature Specifications

	TEMPERATURE RANGE	
	PLENUM	LSZH
INSTALLATION	0°C to +60°C	0°C to +60°C
OPERATION	0°C to +70°C	-20°C to +70°C
STORAGE	-40°C to +70°C	-40°C to +70°C

Contact AFL for further details.

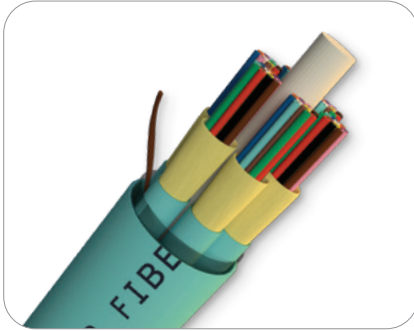

Sub-unitized Premise MicroCore® 2.0

AFL Sub-unitized MicroCore 2.0 cables continue to push evolution of high performance premise cabling. Now available in Base-8 cable configurations up to 144 fibers, and Base-12 configurations up to 216 fibers. MicroCore 2.0 can support all of your high-density network needs, offering the highest density 2.0 mm fiber cables available.

Constructed of the highest quality materials to exacting industry standards, these small-diameter cables provide the solution sought out by today's structured cabling professionals. Each sub-cable is independently qualified and is suitable for individual routing paths within the rack/panel architecture. This enables a flexibility of design and deployment not available in comparable high-density designs. Designed for direct termination and supportive of both single-fiber and multifiber architectures, this cable family should serve as the backbone to any deployed system. Cables are constructed with AFL MicroCore technology consistent with a long line of market leading designs.

Features

- 8-fiber sub-units with 16-144 fibers
- 12-fiber sub-units with 24-216 fibers
- Plenum flame-rated jacket
- All aramid tensile strength members within sub-units

Applications

- Headend termination to a fiber "backbone"
- Termination of fiber rack systems
- Multifloor deployment where select fibers are used at each floor
- Intra-building "backbones"
- MTP/MPO or MTP to break-out terminations

Cable Components

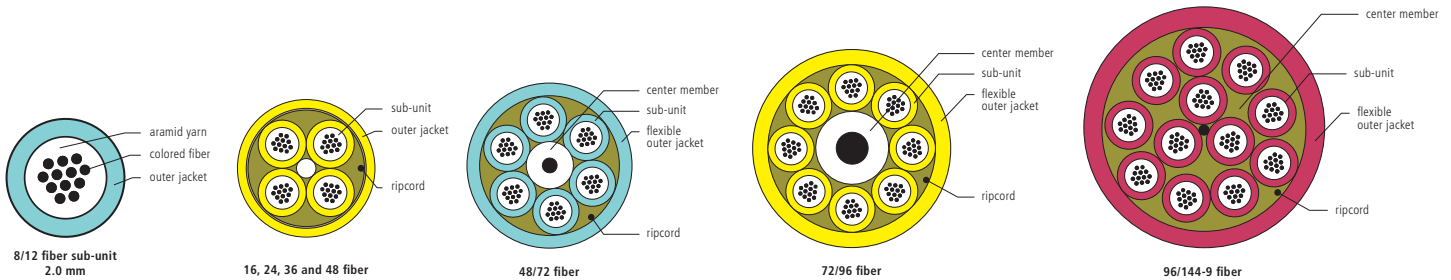

27% Reduction in 72ct Cable Diameter Yields Over 100% Increase in Pathway Capacity

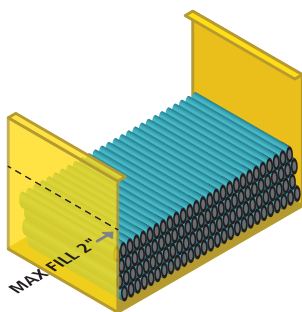

Current 3.0 Sub-unitized Cable in Tray
120 x 72ct cables in standard 4" X 12" tray

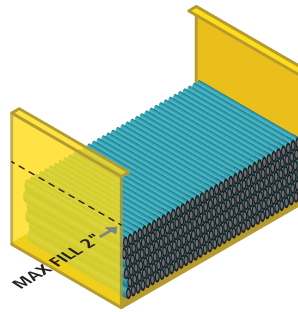

Next Generation Sub-unitized MicroCore 2.0 Cable in Tray
250 x 72ct cables in standard 4" X 12" tray



Sub-unityzed Premise MicroCore® 2.0

Mechanical Data

TYPE	AFL NO.	FIBER COUNT	NO.OF SUBS	NO.OF FILLERS	NOMINAL DIAMETER inches (mm)	WEIGHT lbs/1000 ft (kg/km)	TENSION lbs (N)		BENDING RADIUS inches (cm)	
	PLENUM						INSTALLATION	LONG TERM	INSTALLATION	LONG TERM
8-FIBER SUBUNITS	GQ016★201##B:848	16	4	2	0.27 (7.0)	32 (47)	150 (660)	45 (198)	4.1 (10.5)	2.7 (7.0)
	GQ032★201##B:848	32	4	0	0.27 (7.0)	33 (49)	150 (660)	45 (198)	4.1 (10.5)	2.7 (7.0)
	GQ048★201##B:868	48	6	0	0.32 (8.2)	42 (63)	150 (660)	45 (198)	4.8 (12.3)	3.2 (8.2)
	GQ064★201##B:888	64	8	0	0.33 (8.5)	35 (52)	150 (660)	45 (198)	5.0 (12.8)	3.3 (8.5)
	GQ072★201##B:898	72	9	0	0.40 (10.3)	81 (120)	150 (660)	45 (198)	6.0 (15.5)	4.0 (10.3)
	GQ096★201##B:8C8	96	12	0	0.41 (10.3)	66 (98)	150 (660)	45 (198)	6.1 (15.4)	4.1 (10.3)
12-FIBER SUBUNITS	GQ144★201##B:8I8	144	18	0	0.50 (12.9)	104 (155)	150 (660)	45 (198)	7.5 (19.4)	5.0 (12.9)
	GQ024★201##B:C4C	24	4	2	0.27 (7.0)	33 (49)	150 (660)	45 (198)	4.1 (10.5)	2.7 (7.0)
	GQ036★201##B:C4C	36	4	1	0.27 (7.0)	33 (49)	150 (660)	45 (198)	4.1 (10.5)	2.7 (7.0)
	GQ048★201##B:C4C	48	4	0	0.27 (7.0)	33 (49)	150 (660)	45 (198)	4.1 (10.5)	2.7 (7.0)
	GQ072★201##B:C6C	72	6	0	0.32 (8.2)	44 (66)	150 (660)	45 (198)	4.8 (12.3)	3.2 (8.2)
	GQ096★201##B:C8C	96	8	0	0.43 (10.9)	87 (130)	150 (660)	45 (198)	6.4 (16.4)	4.3 (10.9)
	GQ144★201##B:CCC	144	12	0	0.40 (10.3)	67 (100)	150 (660)	45 (198)	6.0 (15.5)	4.0 (10.3)
	GQ168★201##B:CIC	168	18	4	0.50 (12.9)	108 (160)	150 (660)	45 (198)	7.5 (19.4)	5.0 (12.9)
GQ192★201##B:CIC	192	18	2	0.50 (12.9)	108 (160)	150 (660)	45 (198)	7.5 (19.4)	5.0 (12.9)	
GQ216★201##B:CIC	216	18	0	0.50 (12.9)	108 (160)	150 (660)	45 (198)	7.5 (19.4)	5.0 (12.9)	

★ Fiber Types – Replace asterisk (★) in AFL number with number in the Fiber Specifications table below.
 # Outer Jacket Color – Replace hashtag (#) in AFL number with number in the Cable Jacket Color table below.

Fiber Specifications

CORE SIZE/FIBER TYPE	ISO/IEC	MAXIMUM ATTENUATION (dB/km)			OVERFILL LAUNCH MIN. BANDWIDTH (MHz•km)		EMB _c (MHz•km)	GIGABIT ETHERNET MAX. LINK DISTANCE (meters)		10 GIGABIT ETHERNET MAX. LINK DISTANCE (meters)	
		850 nm	1300 nm	1550 nm	850 nm	1300 nm		850 nm	1300 nm	850 nm	1300 nm
(6) 62.5 Giga-Link™ 300	OM1	3.5	1.2	N/A	200	600	N/A	300	550	32	—
(5) 50 Giga-Link™ 600	OM2	3.5	1.5	N/A	500	500	N/A	600	600	82	—
(L) 50 Laser-Link 300	OM3	3.0	1.2	N/A	1,500	500	2,000	1,000	550	300	—
(C) 50 Laser-Link 550	OM4	3.0	1.2	N/A	3,500	500	4,700	1,040	550	550	—
(W) AFL Wideband Multimode	OM5	3.0	1.2	N/A	3,500	500	4,700	1,040	550	550	—
(9) Single-mode (ITU G.652.D/G.657.A1)	OS2	N/A	0.5	0.5	N/A	N/A	N/A	N/A	5,000	N/A	10,000

Cable Jacket Color Options

1 - Blue	6 - White	B - Rose
2 - Orange	7 - Red	C - Aqua
3 - Green	8 - Black	K - Erika Violet (RAL 4003)
4 - Brown	9 - Yellow	
5 - Slate	A - Violet	

Temperature Specifications

TEMPERATURE RANGE	
INSTALLATION	0°C to +60°C (32°F to +140°F)
OPERATION	0°C to +70°C (32°F to +158°F)
STORAGE	-40°C to +70°C (-40°F to +158°F)

Qualifications

GOVERNING BODY	STANDARD CODE	COMPONENT	GOVERNING BODY	STANDARD CODE	COMPONENT
NFPA	262 (ONFP)	Outer Jacket	ICEA	S-104-696	Sub-units
Telcordia	GR-409-CORE	Sub-units	RoHS	2002/95/EC	Cable
EIA/TIA	568	Sub-units	IEC		

Contact AFL for further details.



Sub-unitized Premise MicroCore® 3.0 Base-12

Sub-unitized Premise MicroCore Cables are ideal for 12-144 fiber high performance premise installations where space is a premium. The round cross-sectional building blocks combine to provide a tight package, while enabling high density architecture. Each 12-fiber sub-unit consists of 250 µm colored fibers and aramid strength members enclosed by a high performance jacket. The sub-units are designed to be independently routed in FMS systems.

Features

- High performance PVC or LSZH outer jackets available
- No preferential bend typically found in stacked ribbon designs
- Small diameter/superior bend performance
- Aramid tensile strength members within sub-units
- Sub-units are suitable for direct termination with round boot MTP

Applications

- In-building cable runs where space is a premium
- Trunk applications where flexibility and small required bend radius are needed to route cable.
- High density cable areas like Data Centers and Central Offices
- Lower cost cable runs where easy handling of tight buffered fibers not needed because cable will be spliced to factory terminated pigtails
- Trunk cables where MTP can be directly terminated on subunits

Cable Components

Key: Q=Plenum, E=LSZH

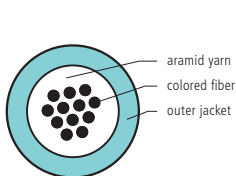

12 fiber sub-unit, Q E

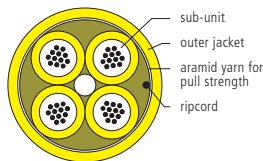

24, 36 and 48 fiber, Q E

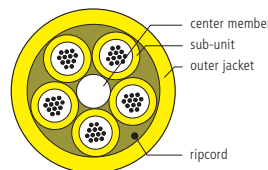

24-60 fiber

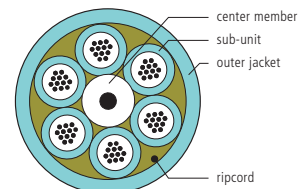

72 fiber, Q E

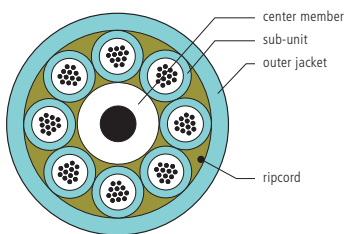

96 fiber, Q E

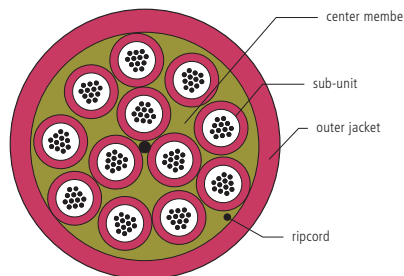

144-9 fiber, Q E

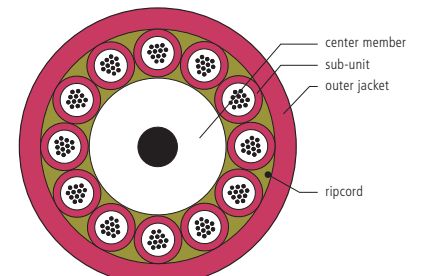

144 fiber



Sub-unitized Premise MicroCore® 3.0 Base-12

Mechanical Data

AFL NO.		FIBER COUNT	NOMINAL DIAMETER	WEIGHT	TENSION		BENDING RADIUS	
PLENUM	LSZH		inches (mm)	lbs/1000 ft (kg/km)	lbs (N)		inches (cm)	
					INSTALLATION	LONG TERM	INSTALLATION	LONG TERM
GQ024★301##B:C4C	GE024★301##B:C4C	24	0.38 (9.7)	54 (80)	150 (660)	45 (198)	5.7 (15.5)	3.8 (9.7)
GQ036★301##B:C4C	GE036★301##B:C4C	36	0.38 (9.7)	54 (80)	150 (660)	45 (198)	5.7 (15.5)	3.8 (9.7)
GQ048★301##B:C4C	GE048★301##B:C4C	48	0.38 (9.7)	54 (80)	150 (660)	45 (198)	5.7 (15.5)	3.8 (9.7)
GQ072★301##B:C6C	GE072★301##B:C6C	72	0.44 (11.1)	84 (125)	150 (660)	45 (198)	6.6 (16.8)	4.4 (11.1)
GQ096★301##B:C8C	GE096★301##B:C8C	96	0.52 (13.3)	118 (175)	150 (660)	45 (198)	7.8 (19.8)	5.2 (13.3)
GQ144★301##B:CCC	GE144★301##B:CCC	144	0.59 (14.9)	124 (185)	150 (660)	45 (198)	5.8 (14.9)	8.8 (22.4)

★ Fiber Types – Replace asterisk (★) in AFL number with number in the Fiber Specifications table below.
 # Outer Jacket Color – Replace hashtag (#) in AFL number with number in the Cable Jacket Color table below.

Fiber Specifications

CORE SIZE/FIBER TYPE	ISO/IEC	MAXIMUM ATTENUATION (dB/km)			OVERFILL LAUNCH MIN. BANDWIDTH (MHz•km)		EMB _c (MHz•km)	GIGABIT ETHERNET MAX. LINK DISTANCE (meters)		10 GIGABIT ETHERNET MAX. LINK DISTANCE (meters)	
		850 nm	1300 nm	1550 nm	850 nm	1300 nm		850 nm	1300 nm	850 nm	1300 nm
(6) 62.5 Giga-Link™ 300	OM1	3.5	1.2	N/A	200	600	N/A	300	550	32	—
(5) 50 Giga-Link™ 600	OM2	3.5	1.5	N/A	500	500	N/A	600	600	82	—
(L) 50 Laser-Link 300	OM3	3.0	1.2	N/A	1,500	500	2,000	1,000	550	300	—
(C) 50 Laser-Link 550	OM4	3.0	1.2	N/A	3,500	500	4,700	1,040	550	550	—
(W) AFL Wideband Multimode	OM5	3.0	1.2	N/A	3,500	500	4,700	1,040	550	550	—
(9) Single-mode (ITU G.652.D/G.657.A1)	OS2	N/A	0.5	0.5	N/A	N/A	N/A	N/A	5,000	N/A	10,000

Cable Jacket Color Options

1 - Blue	4 - Brown	7 - Red	A - Violet	K - Erika Violet (RAL 4003)
2 - Orange	5 - Slate	8 - Black	B - Rose	
3 - Green	6 - White	9 - Yellow	C - Aqua	

Temperature Specifications

	LSZH AND PLENUM	RISER
INSTALLATION	0°C to +70°C	-10°C to +70°C
OPERATION	0°C to +70°C	-10°C to +70°C
STORAGE	-40°C to +70°C	-40°C to +70°C

Qualifications

GOVERNING BODY	STANDARD CODE	COMPONENT
NFPA	262	Plenum Jacket
UL	1666	Riser Jacket
IEC	60754-2, 61034-2, 60332-3-24	LSZH/ONFR-LS Jacket
Telcordia	GR-409-CORE	Jacket
EIA/TIA	568-B3	Jacket
ICEA	S-83-596	Jacket
RoHS	2002/95/EC	Jacket

Contact AFL for further details.

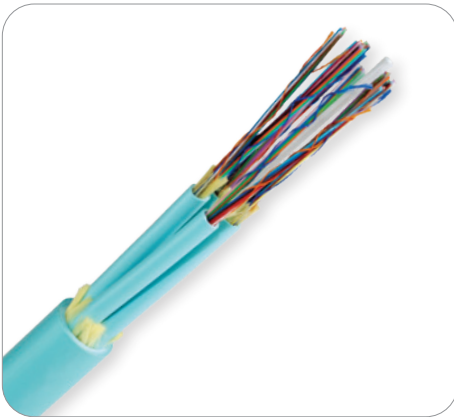

Sub-unitized Premise MicroCore® 3.0 Base-16 and Base-24

The third generation of AFL's Sub-Unitized Premise MicroCore Cable is another astounding evolution of high performance premise cabling. Enabling even greater pathway density than our 2.0 version, the 3.0 revolutionizes cable deployment and allows the end user to realize savings in space, routing infrastructures and fiber management. Combining the highest quality materials with rigorous testing to industry standards, this generation builds on the same quality of construction as the previous versions of our Sub-Unitized Premise MicroCore cables. Also similar to the previous version is the employment of stand-alone sub cables. Each sub-cable is independently qualified and is suitable for individual routing paths within the rack/panel architecture. This flexibility of design and deployment is not available in comparable high density designs. Designed for direct termination, and supportive of both single-fiber and multi-fiber architectures, this cable family is capable of serving as the backbone in any deployed system.

Applications

- In-building cable runs where space is a premium
- Trunk applications where flexibility and small bend radii are required to route cable
- High-density cable areas like data centers and central offices
- Lower cost cable runs where easy handling of tight buffered fibers not needed because cable will be spliced to factory terminated pigtails

Features

- Each sub-unit can stand alone as a rated cable
- 16-fiber sub-units with 32-144 fiber counts
- 24-fiber sub-units with 48-288 fiber counts
- High fiber density—more channels in less space
- No preferential bend direction typically found in stacked ribbon designs
- Small diameter/superior bend performance
- LSZH or Plenum flame-rated jacket
- All aramid tensile strength members around core cable for ease of attaching pulling-eye; aramid within core for use with MT termination

Cable Components

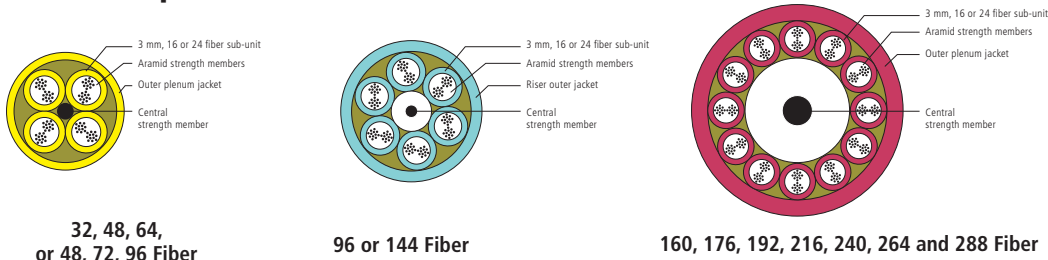

Loose Fiber Specifications

CORE SIZE/FIBER TYPE	ISO/IEC	MAXIMUM ATTENUATION (dB/km)			OVERFILL LAUNCH MIN. BANDWIDTH (MHz•km)		EMB _c (MHz•km)	GIGABIT ETHERNET MAX. LINK DISTANCE (meters)		10 GIGABIT ETHERNET MAX. LINK DISTANCE (meters)	
		850 nm	1300 nm	1550 nm	850 nm	1300 nm		850 nm	1300 nm	850 nm	1300 nm
		(6) 62.5 Giga-Link™ 300	OM1	3.5	1.2	N/A		200	600	N/A	300
(5) 50 Giga-Link™ 600	OM2	3.5	1.5	N/A	500	500	N/A	600	600	82	—
(L) 50 Laser-Link 300	OM3	3.0	1.2	N/A	1,500	500	2,000	1,000	550	300	—
(C) 50 Laser-Link 550	OM4	3.0	1.2	N/A	3,500	500	4,700	1,040	550	550	—
(W) AFL Wideband Multimode	OM5	3.0	1.2	N/A	3,500	500	4,700	1,040	550	550	—
(9) Single-mode (ITU G.652.D/G657.A1)	OS2	N/A	0.5	0.5	N/A	N/A	N/A	N/A	5,000	N/A	10,000

*Other grades of single-mode fiber available.



continued
→

Sub-unitized Premise MicroCore® 3.0 Base-16 and Base-24

Mechanical Data

TYPE	AFL NO. WITH STANDARD LOOSE FIBER		FIBER COUNT	NO. OF SUBS	NO. OF FILLERS	NOMINAL DIAMETER inches (mm)	WEIGHT lbs/1000 ft (kg/km)	TENSION lbs (N)		BENDING RADIUS inches (cm)	
	PLENUM	LSZH						INSTALL	LONG TERM	INSTALL	LONG TERM
16F SUB-UNITS (2X 8F BUNDLES)	GQ032*301##B:G48	GE032*301##B:G48	32	2	2	0.40 (10.2)	60 (90)	150 (670)	45 (200)	6.0 (15.3)	4.0 (10.2)
	GQ048*301##B:G48	GE048*301##B:G48	48	3	1	0.40 (10.2)	60 (90)	150 (670)	45 (200)	6.0 (15.3)	4.0 (10.2)
	GQ064*301##B:G48	GE064*301##B:G48	64	4	0	0.40 (10.2)	60 (90)	150 (670)	45 (200)	6.0 (15.3)	4.0 (10.2)
	GQ080*301##B:G68	GE080*301##B:G68	80	5	1	0.47 (11.9)	107 (160)	150 (670)	45 (200)	7.1 (17.9)	4.7 (11.9)
	GQ096*301##B:G68	GE096*301##B:G68	96	6	0	0.47 (11.9)	107 (160)	150 (670)	45 (200)	7.1 (17.9)	4.7 (11.9)
	GQ112*301##B:G98	GE112*301##B:G98	112	7	2	0.61 (15.5)	171 (255)	150 (670)	45 (200)	9.2 (23.5)	6.1 (15.5)
	GQ128*301##B:G98	GE128*301##B:G98	128	8	1	0.61 (15.5)	171 (255)	150 (670)	45 (200)	9.2 (23.5)	6.1 (15.5)
	GQ144*301##B:G98	GE144*301##B:G98	144	9	0	0.61 (15.5)	171 (255)	150 (670)	45 (200)	9.2 (23.5)	6.1 (15.5)
	GQ160*301##B:GC8	GE160*301##B:GC8	160	10	2	0.72 (18.4)	218 (325)	150 (670)	45 (200)	11.0 (27.6)	7.2 (18.4)
	GQ176*301##B:GC8	GE176*301##B:GC8	176	11	1	0.72 (18.4)	218 (325)	150 (670)	45 (200)	11.0 (27.6)	7.2 (18.4)
24F SUB-UNITS (2X 12F BUNDLES)	GQ192*301##B:GC8	GE192*301##B:GC8	192	12	0	0.72 (18.4)	218 (325)	150 (670)	45 (200)	11.0 (27.6)	7.2 (18.4)
	GQ048*301##B:O4C	GE048*301##B:O4C	48	2	2	0.40 (10.2)	60 (90)	150 (670)	45 (200)	6.0 (15.3)	4.0 (10.2)
	GQ072*301##B:O4C	GE072*301##B:O4C	72	3	1	0.40 (10.2)	60 (90)	150 (670)	45 (200)	6.0 (15.3)	4.0 (10.2)
	GQ096*301##B:O4C	GE096*301##B:O4C	96	4	0	0.40 (10.2)	60 (90)	150 (670)	45 (200)	6.0 (15.3)	4.0 (10.2)
	GQ120*301##B:O6C	GE120*301##B:O6C	120	5	1	0.47 (11.9)	107 (160)	150 (670)	45 (200)	7.1 (17.9)	4.7 (11.9)
	GQ144*301##B:O6C	GE144*301##B:O6C	144	6	0	0.47 (11.9)	107 (160)	150 (670)	45 (200)	7.1 (17.9)	4.7 (11.9)
	GQ168*301##B:O9C	GE168*301##B:O9C	168	7	2	0.61 (15.5)	171 (255)	150 (670)	45 (200)	9.2 (23.5)	6.1 (15.5)
	GQ192*301##B:O9C	GE192*301##B:O9C	192	8	1	0.61 (15.5)	171 (255)	150 (670)	45 (200)	9.2 (23.5)	6.1 (15.5)
	GQ216*301##B:O9C	GE216*301##B:O9C	216	9	0	0.61 (15.5)	171 (255)	150 (670)	45 (200)	9.2 (23.5)	6.1 (15.5)
	GQ240*301##B:OCC	GE240*301##B:OCC	240	10	2	0.72 (18.4)	218 (325)	150 (670)	45 (200)	11.0 (27.6)	7.2 (18.4)
GQ264*301##B:OCC	GE264*301##B:OCC	264	11	1	0.72 (18.4)	218 (325)	150 (670)	45 (200)	11.0 (27.6)	7.2 (18.4)	
GQ288*301##B:OCC	GE288*301##B:OCC	288	12	0	0.72 (18.4)	218 (325)	150 (670)	45 (200)	11.0 (27.6)	7.2 (18.4)	

* Fiber Types—Replace asterisk (*) in AFL No. with number in the Fiber Specifications table on previous page.

Outer Jacket Color – Replace hashtag (#) in AFL No. with number in the Cable Jacket Color table below.

16 unique colors available for fibers in 16 fiber sub-unit: Blue, Orange, Green, Brown, Slate, White, Red, Black, Yellow, Violet, Rose, Aqua, Olive, Tan, Lime, Magenta

Cable Jacket Color Options

1 - Blue	8 - Black
2 - Orange (OM1 and OM2)	9 - Yellow (SM)
3 - Green	A- Violet
4 - Brown	B - Rose
5 - Slate	C - Aqua (OM3 and OM4)
6 - White	K - Erika Violet (OM4)
7 - Red	L - Lime (Pending for OM5)

Qualifications

GOVERNING BODY	STANDARD CODE	COMPONENT
NFPA	262 (ONFP) / FT6	Plenum Jacket
IEC	60332, 60754, 61034	LSZH/ONFR-LS Jacket
Telcordia	GR-409-CORE	Jacket
EIA/TIA	568	Jacket
ICEA		Jacket
RoHS	REACH	Jacket

Temperature Specifications

TEMPERATURE RANGE	
LSZH/PLENUM	
INSTALLATION	0°C to +60°C (32°F to +140°F)
OPERATION	0°C to +70°C (32°F to +158°F)
STORAGE	-40°C to +70°C (-40°F to +158°F)

Contact AFL for further details.

Fiber Optic Cable



Sub-unitized Premise MicroCore[®] 3.0 with SpiderWeb Ribbon[®] (SWR[®]) Technology

The third generation of AFL's Sub-Unitized Premise MicroCore Cable with SWR Technology is another astounding evolution of high performance premise cabling. Enabling even greater pathway density than our 2.0 version, the 3.0 revolutionizes cable deployment and allows the end user to realize savings in space, routing infrastructures and fiber management. Combining the highest quality materials with rigorous testing to industry standards, this generation builds on the same quality of construction as the previous versions of our Sub-Unitized Premise MicroCore cables.



SpiderWeb Ribbon Technology

Additionally, this version features stand-alone sub cables. Each sub cable is independently qualified and is suitable for individual routing paths within the rack/panel architecture. This flexibility of design and deployment is not available in comparable high-density designs. Designed for direct termination and supportive of both single-fiber and multi-fiber architectures, this cable family is capable of serving as the backbone in any deployed system.

SpiderWeb Ribbon is a bonded fiber design allowing for either a highly efficient ribbonizing application or for individual fiber break-outs. This flexibility allows for the application of a single cable design to cover a diverse set of applications. High density round designs allow for the most efficient use of space and materials, resulting in a cost-effective solution.

Applications

- In-building cable runs where space is a premium
- Trunk applications where flexibility and small bend radii are required to route cable
- High-density cable areas like data centers and central offices
- Lower cost cable runs where easy handling of tight buffered fibers not needed because cable will be spliced to factory terminated pigtailed

Features

- SpiderWeb Ribbon technology allows for a highly efficient ribbonizing application or for individual fiber break-outs
- Each sub-unit can stand alone as a rated cable
- 12-fiber sub-units with 12-144 fiber counts
- 24-fiber sub-units with 24-288 fiber counts
- High fiber density—more channels in less space
- No preferential bend direction typically found in stacked ribbon design
- Small diameter/superior bend performance
- LSZH or Plenum flame-rated jacket
- All aramid tensile strength members around core cable for ease of attaching pulling-eye; aramid within core for use with MT termination

Cable Components

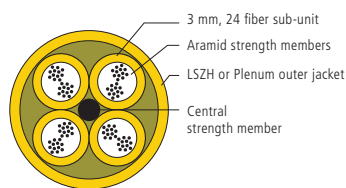

24, 48, 72 and 96 Fiber

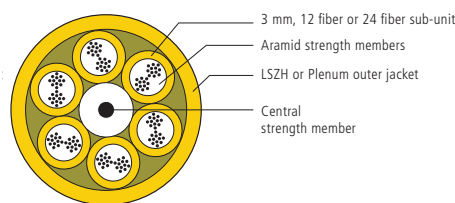

72 and 144 Fiber

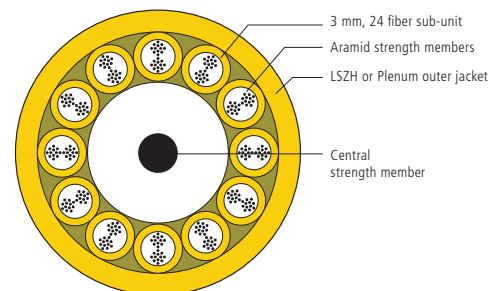

144 and 288 Fiber



Sub-unitized Premise MicroCore® 3.0 with SpiderWeb Ribbon® Technology

Mechanical Data

NO. OF SUBS	NO. OF FILLERS	NOMINAL DIAMETER inches (mm)	WEIGHT lbs/1000 ft (kg/km)	TENSION lbs (N)		BENDING RADIUS inches (cm)	
				INSTALLATION	LONG TERM	INSTALLATION	LONG TERM
1	3	0.40 (10.2)	60 (90)	150 (670)	45 (200)	6.0 (15.3)	4.0 (10.2)
2	2	0.40 (10.2)	60 (90)	150 (670)	45 (200)	6.0 (15.3)	4.0 (10.2)
3	1	0.40 (10.2)	60 (90)	150 (670)	45 (200)	6.0 (15.3)	4.0 (10.2)
4	0	0.40 (10.2)	60 (90)	150 (670)	45 (200)	6.0 (15.3)	4.0 (10.2)
5	1	0.47 (11.9)	107 (160)	150 (670)	45 (200)	7.1 (17.9)	4.7 (11.9)
6	0	0.47 (11.9)	107 (160)	150 (670)	45 (200)	7.1 (17.9)	4.7 (11.9)
7	2	0.56 (14.3)	171 (255)	150 (670)	45 (200)	8.4 (21.5)	5.6 (14.3)
8	1	0.56 (14.3)	171 (255)	150 (670)	45 (200)	8.4 (21.5)	5.6 (14.3)
9	0	0.56 (14.3)	171 (255)	150 (670)	45 (200)	8.4 (21.5)	5.6 (14.3)
10	2	0.62 (15.7)	218 (325)	150 (670)	45 (200)	9.3 (23.6)	6.2 (15.7)
11	1	0.62 (15.7)	218 (325)	150 (670)	45 (200)	9.3 (23.6)	6.2 (15.7)
12	0	0.62 (15.7)	218 (325)	150 (670)	45 (200)	9.3 (23.6)	6.2 (15.7)

SWR Fiber Specifications

CORE SIZE/FIBER TYPE	ISO/IEC	MAXIMUM ATTENUATION (dB/km)			OVERFILL LAUNCH MIN. BANDWIDTH (MHz•km)		EMB _c (MHz•km)	GIGABIT ETHERNET MAX. LINK DISTANCE (meters)		10 GIGABIT ETHERNET MAX. LINK DISTANCE (meters)	
		850 nm	1300 nm	1550 nm	850 nm	1300 nm		850 nm	1300 nm	850 nm	1300 nm
(P) AFL Bend-Insensitive Single-mode (ITU G.652.D/G.657.A1)	OS2	N/A	0.5	0.5	N/A	N/A	N/A	N/A	5,000	N/A	10,000

Cable Jacket Color Options

1 - Blue	8 - Black
2 - Orange	9 - Yellow (SM)
3 - Green	A - Violet
4 - Brown	B - Rose
5 - Slate	C - Aqua (OM3 and OM4)
6 - White	K - Erika Violet (OM4)
7 - Red	L - Lime

Qualifications

GOVERNING BODY	STANDARD CODE	COMPONENT
NFPA	262 (ONFP) / FT6	Plenum Jacket
IEC	60332, 60754, 61034	LSZH/OFNR-LS Jacket
Telcordia	GR-409-CORE	Jacket
EIA/TIA	568	Jacket
ICEA		Jacket
RoHS	REACH	Jacket

Temperature Specifications

TEMPERATURE RANGE	
	LSZH/PLENUM
INSTALLATION	0°C to +60°C
OPERATION	0°C to +70°C
STORAGE	-40°C to +70°C

Contact AFL for further details.

continued
→



Sub-unitized Premise MicroCore® 3.0 with SpiderWeb Ribbon® Technology

Ordering Information

CABLE TYPE	FIBER COUNT	NO. OF SUBS	NO. OF FILLERS	AFL NO.	
				SINGLE-MODE	
				PLENUM	LSZH
12 Fiber Subunit	12	1	3	GQ012P301##R:C4C	GE012P301##R:C4C
	24	2	2	GQ024P301##R:C4C	GE024P301##R:C4C
	36	3	1	GQ036P301##R:C4C	GE036P301##R:C4C
	48	4	0	GQ048P301##R:C4C	GE048P301##R:C4C
	60	5	1	GQ060P301##R:C6C	GE060P301##R:C6C
	72	6	0	GQ072P301##R:C6C	GE072P301##R:C6C
	84	7	1	GQ084P301##R:C8C	GE084P301##R:C8C
	96	8	0	GQ096P301##R:C8C	GE096P301##R:C8C
	120	10	2	GQ120P301##R:CCC	GE120P301##R:CCC
	132	11	1	GQ132P301##R:CCC	GE132P301##R:CCC
24 Fiber Subunit	144	12	0	GQ144P301##R:CCC	GE144P301##R:CCC
	24	1	3	GQ024P301##R:O4C	GE024P301##R:O4C
	48	2	2	GQ048P301##R:O4C	GE048P301##R:O4C
	72	3	1	GQ072P301##R:O4C	GE072P301##R:O4C
	96	4	0	GQ096P301##R:O4C	GE096P301##R:O4C
	120	5	1	GQ120P301##R:O6C	GE120P301##R:O6C
	144	6	0	GQ144P301##R:O6C	GE144P301##R:O6C
	168	7	2	GQ168P301##R:O9C	GE168P301##R:O9C
	192	8	1	GQ192P301##R:O9C	GE192P301##R:O9C
	216	9	0	GQ216P301##R:O9C	GE216P301##R:O9C
240	10	2	GQ240P301##R:OCC	GE240P301##R:OCC	
264	11	1	GQ264P301##R:OCC	GE264P301##R:OCC	
288	12	0	GQ288P301##R:OCC	GE288P301##R:OCC	

Notes:

- Replace first # with number corresponding to desired jacket color from Cable Jacket Color Options table on previous page.
- Replace second # with number corresponding to desired subunit color from Cable Jacket Color Options table on previous page.

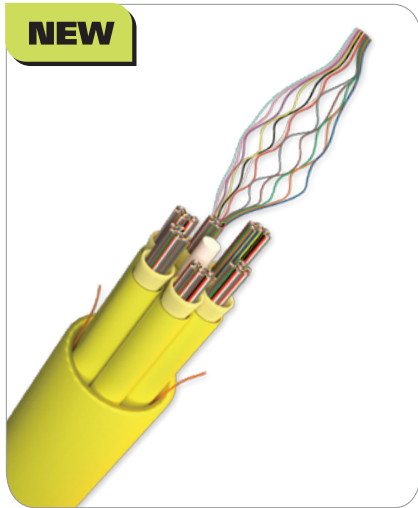

Ultra HD MicroCore® Riser Fiber Optic Cable

The Ultra HD MicroCore Riser fiber optic cable is the latest development in AFL's sub-unitized MicroCore cable family that uses SpiderWeb Ribbon® (SWR®) technology. Designed to support high fiber density deployments in data center and central office installation environments, the ultra HD sub-unit designs optimize splicing efficiency when interconnected with AFL's Wrapping Tube Cable (WTC).

With continued requirements for higher bandwidth, higher fiber density cabling products are critical to support that demand. Ultra HD MicroCore cable designs feature 72-fiber and 144-fiber sub-units that result in maximum fiber counts up to 864 and 1,728 respectively. The cable consists of an OFNR/FT4 (UL1666) flame-rated outer jacket with an installation tension rating of 150 lbs., qualified to meet and exceed the requirements of the latest Telcordia GR-409-CORE inside plant cabling requirements.

Features

- SpiderWeb Ribbon**
 Collapsible ribbon reduces size of cable compared to other encapsulated or pliable ribbon technologies
- OFNR Riser Rating**
 Can be routed within designated riser spaces within build structures
- Small Diameter**
 Because of the smaller diameter, more optical fibers can be placed into crowded or limited-space pathways

SWR Technology

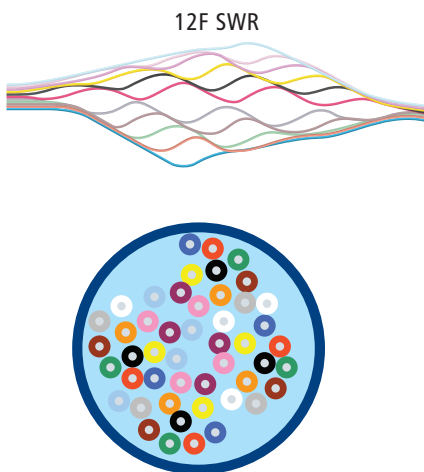

Multiple 12F SWR subunits

72F OR 144F subunits depending on cable fiber count

Cable Components

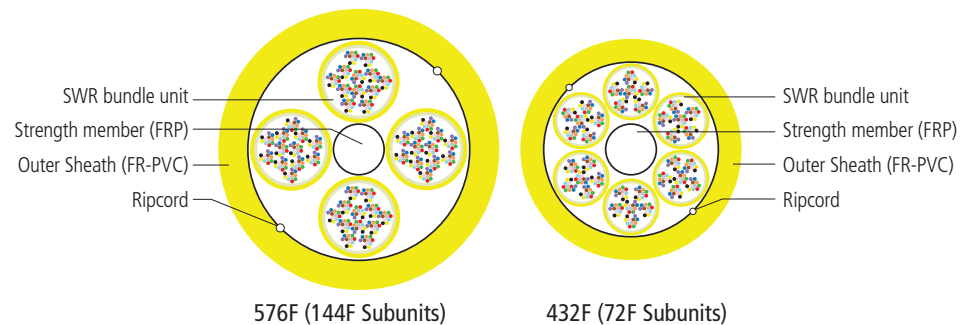



Ultra HD MicroCore® Riser Fiber Optic Cable

Mechanical Data

CABLE TYPE	AFL NO.	FIBER COUNT	NO. OF SUBS	NO. OF FILLERS	SINGLE-MODE		MAXIMUM TENSILE LOAD		MINIMUM BEND RADIUS	
					NOMINAL DIAMETER	WEIGHT	INSTALL	LONG TERM	INSTALL	LONG TERM
					inches (mm)	lbs/1,000 ft (kg/km)	lbs (N)	lbs (N)	inches (mm)	inches (mm)
72F Subunits	GR144P45199R:T4C	144	2	2	0.551 (14.0)	103 (153)	150 (660)	45 (200)	8.27 (210)	5.51 (140)
	GR216P45199R:T4C	216	3	1	0.551 (14.0)	107 (159)	150 (660)	45 (200)	8.27 (210)	5.51 (140)
	GR288P45199R:T4C	288	4	0	0.551 (14.0)	115 (165)	150 (660)	45 (200)	8.27 (210)	5.51 (140)
	GR432P45199R:T6C	432	6	0	0.650 (16.5)	165 (240)	150 (660)	45 (200)	9.75 (248)	6.50 (165)
	GR864P50199R:TCC	864	12	0	0.925 (23.5)	339 (505)	150 (660)	45 (200)	13.88 (353)	9.25 (235)
144F Subunits	GR144P70199R:U4C	144	1	3	0.787 (20.0)	177 (264)	150 (660)	45 (200)	11.81 (300)	7.87 (200)
	GR288P70199R:U4C	288	2	2	0.787 (20.0)	194 (288)	150 (660)	45 (200)	11.81 (300)	7.87 (200)
	GR432P70199R:U4C	432	3	1	0.787 (20.0)	165 (240)	150 (660)	45 (200)	11.81 (300)	7.87 (200)
	GR576P70199R:U4C	576	4	0	0.787 (20.0)	210 (300)	150 (660)	45 (200)	11.81 (300)	7.87 (200)
	GR1728P60199R:UCC	1728	12	0	1.09 (27.8)	410 (605)	150 (660)	45 (200)	16.35 (605)	10.09 (278)

Fiber Specifications

CORE SIZE/FIBER TYPE	ISO/IEC	MAXIMUM ATTENUATION (dB/km)			OVERFILL LAUNCH MIN. BANDWIDTH (MHz•km)		EMBC (MHz•km)	GIGABIT ETHERNET MAX. LINK DISTANCE (meters)		10 GIGABIT ETHERNET MAX. LINK DISTANCE (meters)	
		850 nm	1300 nm	1550 nm	850 nm	1300 nm		850 nm	1300 nm	850 nm	1300 nm
(P) AFL Single-mode (ITU G.652.D/G.657.A1)	OS2	N/A	0.5	0.5	N/A	N/A	N/A	N/A	5,000	N/A	10,000

WTC to Ultra HD MicroCore Pairing Chart

FIBER COUNT	WTC BINDER UNIT CONFIGURATION	RECOMMENDED ULTRA HD MICROCORE CABLE DESIGNS											
288F	4 Binder Units <table border="1" style="display: inline-table; vertical-align: middle;"><tr><td>1</td><td>2</td><td>3</td><td>4</td></tr></table>	1	2	3	4	1-6 Ring Marking (72F Subunits) Ultra HD MicroCore 144F up to 864F (72F subs)							
1	2	3	4										
432F	6 Binder Units <table border="1" style="display: inline-table; vertical-align: middle;"><tr><td>1</td><td>2</td><td>3</td><td>4</td><td>5</td><td>6</td></tr></table>	1	2	3	4		5	6					
1	2	3	4	5	6								
576F	8 Binder Units <table border="1" style="display: inline-table; vertical-align: middle;"><tr><td>1</td><td>2</td><td>3</td><td>4</td><td>5</td><td>6</td><td>7</td><td>8</td></tr></table>	1	2	3	4	5	6	7	8				
1	2	3	4	5	6	7	8						
864F	12 Binder Units <table border="1" style="display: inline-table; vertical-align: middle;"><tr><td>1</td><td>2</td><td>3</td><td>4</td><td>5</td><td>6</td><td>7</td><td>8</td><td>9</td><td>10</td><td>11</td><td>12</td></tr></table>	1	2	3	4	5	6	7	8	9	10	11	12
1	2	3	4	5	6	7	8	9	10	11	12		
1152F	8 Binder Units <table border="1" style="display: inline-table; vertical-align: middle;"><tr><td>1</td><td>2</td><td>3</td><td>4</td><td>5</td><td>6</td><td>7</td><td>8</td></tr></table>	1	2	3	4	5	6	7	8	1-12 Ring Marking (144F Bundles) Ultra HD MicroCore 144F up to 1,728F (144F subs)			
1	2	3	4	5	6	7	8						
1728F	12 Binder Units <table border="1" style="display: inline-table; vertical-align: middle;"><tr><td>1</td><td>2</td><td>3</td><td>4</td><td>5</td><td>6</td><td>7</td><td>8</td><td>9</td><td>10</td><td>11</td><td>12</td></tr></table>	1	2	3	4	5	6	7	8	9	10	11	12
1	2	3	4	5	6	7	8	9	10	11	12		

Qualifications

GOVERNING BODY	STANDARD CODE	COMPONENT
UL	1666	Listed Riser
ANSI/ICEA	S-83-596	Fiber
Telcordia	GR-409-CORE Issue 2	Indoor Fiber Optic Cable

Temperature Specifications

TEMPERATURE RANGE	
OPERATION	0°C to +70°C
STORAGE	-40°C to +70°C
INSTALLATION	0°C to +60°C

Contact AFL for your Ultra HD MicroCore cable solution.

eABF® Solutions

eABF Cable

At the heart of the eABF solution is the cable and the duct. The eABF cable has been designed to offer exceptional air-jetting qualities yet rugged enough to comply with Telcordia’s GR-409 Premise Cabling standard and NEC Riser and Plenum flame ratings even outside of the MicroDuct. As a result, the cable can be deployed once exiting the pathway without the need for additional costly furcation tubing as required by other less robust alternatives. The cable is available in fiber counts from six through 144 with all fiber types including SMF, OM2, OM3 and OM4, and employs bend-insensitive fiber technology.

eABF MicroDuct

The eABF pathway system is comprised of Enterprise FuturePath® MicroDuct products engineered and produced by Dura-Line, the premier communications-oriented fiber optic duct system. The eABF duct options include indoor/outdoor riser, plenum, low-smoke zero halogen (LSZH) and HDPE product lines. All eABF ducts incorporate low-contact ribbed inner surface and ultra-low friction SILICORE®. The eABF FuturePath MicroDuct comes in tube counts from two through 24.

System

AFL and Dura-Line have joined together to produce a high-performance blown fiber optic cabling system with applications across a broad spectrum of networking configurations. The solution, eABF (Enterprise Blown Fiber) cabling system is engineered to offer a reliable, easy-to-install optical fiber network communications infrastructure that has one of the highest fiber density solutions in the blown fiber market. The eABF solution has all the key elements that, when combined, yield a state-of-the-art and highly flexible “living” communications pathway.

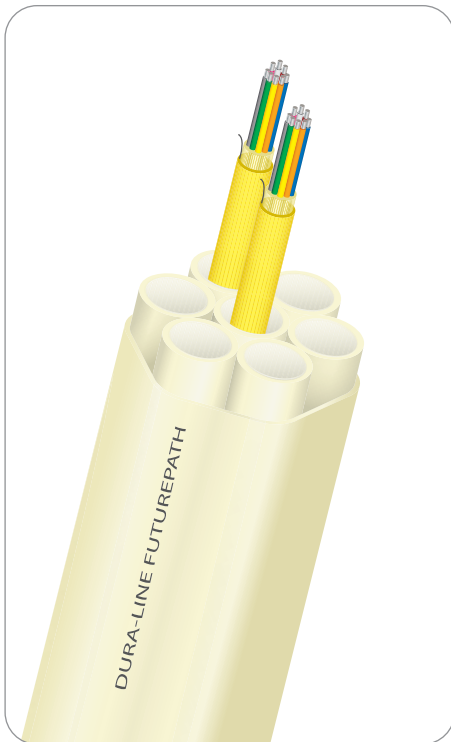

- AFL eABF Cables
- Dura-Line Enterprise FuturePath MicroDuct
- AFL Connectivity
- AFL Test Equipment and Fusion Splicers
- ACE Lifetime* Warranty
- Design, BOM and SOW Support
- Contractor Training and Project Management

*Lifetime is defined as the System Design Lifetime which is 25 years.

eABF Solutions

CABLES	
	<p>Enterprise Blown Cable (6-144 fibers)</p> <p>Specifically designed for air-jetting applications through MicroDuct pathways. The proprietary high-drag, light-weight design yields a cable that performs well during installation and yet offers a very robust and compact package for direct routing through congested point-of-termination cable management locations. These cables are GR-409 compliant and come in OFNP and OFNR ratings.</p>
	<p>Enterprise Blown OSP MicroCore® Cable (LM Series)</p> <p>Available in fiber counts up to 432 in blowable and pullable designs. Stranded buffer tubes simplify splicing/handling and allow for mid-span access to the fibers. The AFL OSP MicroCore series includes one of the industry's highest fiber densities yet maintains a minimum 300-lb load rating for installation.</p>
MICRODUCT SYSTEMS	
	<p>Enterprise FuturePath</p> <p>Enterprise FuturePath is available in many sizes and configurations including riser, plenum and LSZH. MicroDuct sizes include 12.7 mm and 8.5 mm to accommodate your fiber requirements. Configurations from single MicroDucts to 24 pathways allow for rapid deployment of fiber today with permanent pathways in place for future growth.</p>
	<p>OSP FuturePath</p> <p>OSP FuturePath is available in many sizes and configurations for outside plant network installations. The same broad range of MicroDuct options found in the Enterprise products plus a large range of inner duct sizes are available. All FuturePath products come in armored and non-armored designs.</p>
CONNECTIVITY AND TEST EQUIPMENT	
	<p>Poli-MOD® Patch and Splice Module</p> <p>The Poli-MOD is an innovative patch and splice module which allows for increased densities in an incremental growth platform. Based on the LGX® 118 footprint, this product is capable of supporting up to 144 patch and splices in a standard 4U panel, resulting in 1296 patch and splices within a seven foot rack (38RU).</p>
	<p>Field-Installable Connectors</p> <p>FASTConnect®: Factory pre-polished, field-installable connectors that completely eliminate the need for hand polishing in the field.</p> <p>FUSEConnect®: With a factory pre-polished ferrule, its innovative field-termination process eliminates polishing, adhesives and crimping in the field, minimizing the potential for operator error and expensive connector scrap.</p>
	<p>Test, Inspection and Cleaning Equipment</p> <p>AFL's test, inspection and cleaning products consistently meet and exceed customer needs. AFL delivers exceptional fiber optic test equipment and outstanding service. Our ISO 9001:2008 certification and quality practices ensure you receive excellent products and documentation.</p>
	<p>Fusion Splicing Equipment</p> <p>AFL offers an extensive lineup of fusion splicers for field splicing applications. From the world's smallest fusion splicer to the world's first fully ruggedized splicer, Fujikura has been the pioneer in fusion splicing technology since 1979. Current generation field models offer unmatched speed, ruggedness and reliability.</p>
25-Year Warranty on End-to-End Fiber Optic Systems	
	<p>ACE Program 25-Year Warranty</p> <p>Standards-based, 25-year performance warranty written around performance standards to give your customers peace of mind for the 25-year design life of their fiber installation.</p>

eABF® Fiber Optic Cable

eABF® Solutions

Lifetime Warranty on End-to-End Fiber Optic Systems

As the first telecommunications company to offer a lifetime warranty* on end-to-end fiber optic systems including eABF systems, AFL partners with system integrators that possess the same quality of workmanship as we do. We carefully select partners that are as stringent about quality workmanship as we are at AFL. Plus, we are continually building our network of AFL Certified Expert (ACE) Installers that design and install AFL systems.

As an ACE Installer, you will be confident in designing and installing an AFL system that will fit the needs of your customers, as well as give them the peace of mind that a lifetime warranty offers. This, coupled with AFL's excellent technical support and the best products and solutions in the industry, will truly differentiate you from your competition.

AFL offers each ACE Installer extensive hands-on training that will help you understand the products we manufacture better, as well as develop your fiber optic knowledge and installation practices. After the training is complete, you will have all the necessary tools to design and install a completely warranted AFL system.

Learn more about the ACE program at www.afglobal.com/Resources/AFL-Certified-Expert-Installers-Program.aspx.



ACE Program Highlights

- Cutting-edge technology – develop a better understanding of fiber technology ensuring you remain ahead of your competition
- Single-source fiber supplier – one company to go to for all of your fiber and technical support needs
- Standards-based, 25-year performance warranty written around performance standards to give your customers peace of mind for the 25-year design life of their fiber installation
 - ANSI/TIA-568-C.0, *Generic Telecommunications Cabling for Customer Premises*
 - ANSI/TIA-568-C.3, *Optical Fiber Cabling Components Standard*
- Fiber training, design and support – become more proficient in designing, installing and testing a fiber system
- BICSI credits – AFL's ACE training programs are BICSI-certified and qualify for BICSI continuing education credits (CEC)
- Engineering support – an engineer on call to help you better understand any technical issues so you can find the solution that best fits your customers needs and applications
- Marketing incentives – gain access to the power behind the AFL brand, including links on our website promoting you as an ACE Installer
- Rebate program – Earn rebates based on AFL product purchases from an authorized distributor

*Lifetime is defined as the System Design Lifetime which is 25 years.

Enterprise Blown Fiber (eABF®) Cable

eABF cables are designed by AFL to offer the most rugged and reliable enterprise-based blown fiber solution in the market today. The cable design combines a light-weight, high-drag jacketing system that allows the cable to be blown long distances. The cable series also features additional attributes that set this product above and beyond traditional blown fiber cables. These enhanced features include mechanical strengthening that permits the cable to comply with industry-standard premise interconnect specifications. In addition, the eABF cable series feature flame-resistance characteristics which result in stand-alone riser and plenum rated options suitable for routing outside of the micro-duct system. Because of these mechanical, environmental and optical qualifications, eABF cables can also be installed in third-party, flame-rated duct and pathway systems.

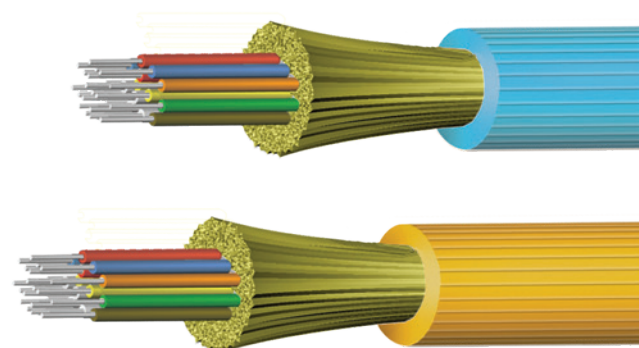

Features

- Contains water-blocking components for additional fiber protection from accidental water exposure
- Can be installed in eABF duct or third-party rated duct systems
- Complete range of single-mode and multimode fibers to support 10G, 40G and 100G Ethernet architectures
- Aramid-strengthened cable core for robust tensile load bearing capabilities
- OD compatible with 6 mm ID Micro-ducts for higher density fiber pathway solutions
- 96-Fiber count fits into 8.5 mm x 6 mm Micro-duct for up to 2,304 fibers per 24-way Dura-Line FuturePath Duct

Applications

- Designed for Data Center Interconnect
- Horizontal Distribution
- Backbone Distribution
- Low-cost fiber upgrade migration strategies

Specifications – eABF Optical Fiber

FIBER TYPE	ISO DESIGNATION	MAXIMUM ATTENUATION (dB/km)				Overfill Launch Min. Bandwidth (MHz-km)		EMBc (MHz-km)	GIGABIT ETHERNET MAX. LINK DISTANCE (Meters)		10 GIGABIT ETHERNET MAX. LINK DISTANCE (Meters)	
		850 nm	1300 nm	1310 nm	1550 nm	850 nm	1300 nm		850 nm	1300 nm	850 nm	1300 nm
62.5/125	OM1	3.5	1.2	N/A	N/A	200	600	N/A	300	550	32	N/A
50/125	OM2 BIF	3.5	1.2	N/A	N/A	500	500	N/A	600	600	82	N/A
50/125	OM3 BIF	3.0	1.2	N/A	N/A	1500	500	2000	1000	550	300	N/A
50/125	OM4 BIF	3.0	1.2	N/A	N/A	3500	550	4700	1040	550	550	N/A
SM	OS2 (G.652D/ G.657.A1)	N/A	N/A	0.4	0.4	N/A	N/A	N/A	N/A	N/A	N/A	N/A

BIF = Bend Insensitive Fiber

Estimated Installation Distances

OD/ID	DISTANCE (ft)
V-20 Install Distance—eABF 3.6 mm (6-24 Fibers)	
8.5 x 6	3,000
V-20 Install Distance—eABF 3.8 mm (48 Fibers)	
8.5 x 6	2,500
V-20 Install Distance—eABF 4.5 mm (72-96 Fibers)	
8.5 x 6	1,500

continued
→

Enterprise Blown Fiber (eABF®) Cable

Mechanical Data—Riser (OFNR)

DURA-LINE NO.	DESCRIPTION	PRODUCT TYPE	FIBER COUNT	NOMINAL DIAMETER	WEIGHT	MAXIMUM TENSILE LOAD		MINIMUM BEND RADIUS	
				Inches (mm)		Lbs/1,000 ft (kg/km)	SHORT TERM lbs (N)	LONG TERM lbs (N)	SHORT TERM Inches (mm)
20002960	MicroCable Riser ENT-A SM-6	SMF	6	0.14 (3.6)	6.4 (9.5)	22 (100)	7 (30)	1.2 (30)	0.8 (20)
20002866	MicroCable Riser ENT-A SM-12	SMF	12	0.14 (3.6)	6.7 (10.0)	22 (100)	7 (30)	1.2 (30)	0.8 (20)
20000729	MicroCable Riser ENT-A SM-24	SMF	24	0.14 (3.6)	7.4 (11.0)	22 (100)	7 (30)	1.2 (30)	0.8 (20)
20000730	MicroCable Riser ENT-A SM-48	SMF	48	0.15 (3.8)	9.4 (14.0)	22 (100)	7 (30)	1.2 (30)	0.8 (20)
20003201	MicroCable Riser ENT-A SM-72	SMF	72	0.18 (4.5)	14.0 (20.8)	22 (100)	7 (30)	3.6 (90)	1.8 (45)
20003628	MicroCable Riser SMF-72 200 µm	SMF 200 µm	72	0.15 (3.8)	11.0 (16.4)	22 (100)	7 (30)	1.2 (30)	0.8 (20)
20003630	MicroCable Riser ENT-A SM-96	SMF 200 µm	96	0.18 (4.5)	16.0 (23.8)	22 (100)	7 (30)	3.6 (90)	1.8 (45)
20002961	MicroCable Riser ENT-A OM1-6	OM1 (62.5/125)	6	0.14 (3.6)	6.4 (9.5)	22 (100)	7 (30)	1.2 (30)	0.8 (20)
20002848	MicroCable Riser ENT-A OM1-12	OM1 (62.5/125)	12	0.14 (3.6)	6.7 (10.0)	22 (100)	7 (30)	1.2 (30)	0.8 (20)
20002962	MicroCable Riser ENT-A OM1-24	OM1 (62.5/125)	24	0.14 (3.6)	7.4 (11.0)	22 (100)	7 (30)	1.2 (30)	0.8 (20)
20002963	MicroCable Riser ENT-A OM1-48	OM1 (62.5/125)	48	0.15 (3.8)	9.4 (14.0)	22 (100)	7 (30)	1.2 (30)	0.8 (20)
20003333	MicroCable Riser ENT-A OM1-72	OM1 (62.5/125)	72	0.18 (4.5)	14.0 (20.8)	22 (100)	7 (30)	3.6 (90)	1.8 (45)
20002964	MicroCable Riser ENT-A OM2-6	OM2 (50/125)	6	0.14 (3.6)	6.4 (9.5)	22 (100)	7 (30)	1.2 (30)	0.8 (20)
20002965	MicroCable Riser ENT-A OM2-12	OM2 (50/125)	12	0.14 (3.6)	6.7 (10.0)	22 (100)	7 (30)	1.2 (30)	0.8 (20)
20002966	MicroCable Riser ENT-A OM2-24	OM2 (50/125)	24	0.14 (3.6)	7.4 (11.0)	22 (100)	7 (30)	1.2 (30)	0.8 (20)
20002967	MicroCable Riser ENT-A OM2-48	OM2 (50/125)	48	0.15 (3.8)	9.4 (14.0)	22 (100)	7 (30)	1.2 (30)	0.8 (20)
20003334	MicroCable Riser ENT-A OM2-72	OM2 (50/125)	72	0.18 (4.5)	14.0 (20.8)	22 (100)	7 (30)	3.6 (90)	1.8 (45)
20002968	MicroCable Riser ENT-A OM3-6	OM3 (50/125)	6	0.14 (3.6)	6.4 (9.5)	22 (100)	7 (30)	1.2 (30)	0.8 (20)
20002969	MicroCable Riser ENT-A OM3-12	OM3 (50/125)	12	0.14 (3.6)	6.7 (10.0)	22 (100)	7 (30)	1.2 (30)	0.8 (20)
20000695	MicroCable Riser ENT-A OM3-24	OM3 (50/125)	24	0.14 (3.6)	7.4 (11.0)	22 (100)	7 (30)	1.2 (30)	0.8 (20)
20002883	MicroCable Riser ENT-A OM3-48	OM3 (50/125)	48	0.15 (3.8)	9.4 (14.0)	22 (100)	7 (30)	1.2 (30)	0.8 (20)
20003335	MicroCable Riser ENT-A OM3-72	OM3 (50/125)	72	0.18 (4.5)	14.0 (20.8)	22 (100)	7 (30)	3.6 (90)	1.8 (45)
20002970	MicroCable Riser ENT-A OM4-6	OM4 (50/125)	6	0.14 (3.6)	6.4 (9.5)	22 (100)	7 (30)	1.2 (30)	0.8 (20)
20002971	MicroCable Riser ENT-A OM4-12	OM4 (50/125)	12	0.14 (3.6)	6.7 (10.0)	22 (100)	7 (30)	1.2 (30)	0.8 (20)
20002972	MicroCable Riser ENT-A OM4-24	OM4 (50/125)	24	0.14 (3.6)	7.4 (11.0)	22 (100)	7 (30)	1.2 (30)	0.8 (20)
20000696	MicroCable Riser ENT-A OM4-48	OM4 (50/125)	48	0.15 (3.8)	9.4 (14.0)	22 (100)	7 (30)	1.2 (30)	0.8 (20)
20003272	MicroCable Riser ENT-A OM4-72	OM4 (50/125)	72	0.18 (4.5)	14.0 (20.8)	22 (100)	7 (30)	3.6 (90)	1.8 (45)

continued



Enterprise Blown Fiber (eABF®) Cable

Mechanical Data—Plenum (OFNP)

DURA-LINE NO.	DESCRIPTION	PRODUCT TYPE	FIBER COUNT	NOMINAL DIAMETER	WEIGHT	MAXIMUM TENSILE LOAD		MINIMUM BEND RADIUS	
				Inches (mm)		Lbs/1,000 ft (kg/km)	SHORT TERM lbs (N)	LONG TERM lbs (N)	SHORT TERM Inches (mm)
20002973	MicroCable Plenum ENT-A SM-6	SMF	6	0.14 (3.6)	6.4 (9.5)	22 (100)	7 (30)	1.2 (30)	0.8 (20)
20002974	MicroCable Plenum ENT-A SM-12	SMF	12	0.14 (3.6)	6.7 (10.0)	22 (100)	7 (30)	1.2 (30)	0.8 (20)
20002975	MicroCable Plenum ENT-A SM-24	SMF	24	0.14 (3.6)	7.4 (11.0)	22 (100)	7 (30)	1.2 (30)	0.8 (20)
20001451	MicroCable Plenum ENT-A SM-48	SMF	48	0.15 (3.8)	9.4 (14.0)	22 (100)	7 (30)	1.2 (30)	0.8 (20)
20003337	MicroCable Plenum ENT-A SM-72	SMF	72	0.18 (4.5)	15.0 (22.3)	22 (100)	7 (30)	3.6 (90)	1.8 (45)
20003629	MicroCable Plenum SMF-72 200 µm	SMF 200 µm	72	0.15 (3.8)	11.0 (16.4)	22 (100)	7 (30)	1.2 (30)	0.8 (20)
20003631	MicroCable Plenum ENT-A SM-96	SMF 200 µm	96	0.18 (4.5)	16.0 (23.8)	22 (100)	7 (30)	3.6 (90)	1.8 (45)
20002976	MicroCable Plenum ENT-A M1-6	OM1 (62.5/125)	6	0.14 (3.6)	6.4 (9.5)	22 (100)	7 (30)	1.2 (30)	0.8 (20)
20002977	MicroCable Plenum ENT-A OM1-12	OM1 (62.5/125)	12	0.14 (3.6)	6.7 (10.0)	22 (100)	7 (30)	1.2 (30)	0.8 (20)
20002978	MicroCable Plenum ENT-A OM1-24	OM1 (62.5/125)	24	0.14 (3.6)	7.4 (11.0)	22 (100)	7 (30)	1.2 (30)	0.8 (20)
20002979	MicroCable Plenum ENT-A OM1-48	OM1 (62.5/125)	48	0.15 (3.8)	9.4 (14.0)	22 (100)	7 (30)	1.2 (30)	0.8 (20)
20003338	MicroCable Plenum ENT-A OM1-72	OM1 (62.5/125)	72	0.18 (4.5)	15.0 (22.3)	22 (100)	7 (30)	3.6 (90)	1.8 (45)
20002980	MicroCable Plenum ENT-A OM2-6	OM2 (50/125)	6	0.14 (3.6)	6.4 (9.5)	22 (100)	7 (30)	1.2 (30)	0.8 (20)
20002981	MicroCable Plenum ENT-A OM2-12	OM2 (50/125)	12	0.14 (3.6)	6.7 (10.0)	22 (100)	7 (30)	1.2 (30)	0.8 (20)
20002982	MicroCable Plenum ENT-A OM2-24	OM2 (50/125)	24	0.14 (3.6)	7.4 (11.0)	22 (100)	7 (30)	1.2 (30)	0.8 (20)
20002983	MicroCable Plenum ENT-A OM2-48	OM2 (50/125)	48	0.15 (3.8)	9.4 (14.0)	22 (100)	7 (30)	1.2 (30)	0.8 (20)
20003339	MicroCable Plenum ENT-A OM2-72	OM2 (50/125)	72	0.18 (4.5)	15.0 (22.3)	22 (100)	7 (30)	3.6 (90)	1.8 (45)
20002984	MicroCable Plenum ENT-A OM3-6	OM3 (50/125)	6	0.14 (3.6)	6.4 (9.5)	22 (100)	7 (30)	1.2 (30)	0.8 (20)
20002985	MicroCable Plenum ENT-A OM3-12	OM3 (50/125)	12	0.14 (3.6)	6.7 (10.0)	22 (100)	7 (30)	1.2 (30)	0.8 (20)
20002986	MicroCable Plenum ENT-A OM3-24	OM3 (50/125)	24	0.14 (3.6)	7.4 (11.0)	22 (100)	7 (30)	1.2 (30)	0.8 (20)
20002987	MicroCable Plenum ENT-A OM3-48	OM3 (50/125)	48	0.15 (3.8)	9.4 (14.0)	22 (100)	7 (30)	1.2 (30)	0.8 (20)
20003340	MicroCable Plenum ENT-A OM3-72	OM3 (50/125)	72	0.18 (4.5)	15.0 (22.3)	22 (100)	7 (30)	3.6 (90)	1.8 (45)
20002988	MicroCable Plenum ENT-A OM4-6	OM4 (50/125)	6	0.14 (3.6)	6.4 (9.5)	22 (100)	7 (30)	1.2 (30)	0.8 (20)
20002989	MicroCable Plenum ENT-A OM4-12	OM4 (50/125)	12	0.14 (3.6)	6.7 (10.0)	22 (100)	7 (30)	1.2 (30)	0.8 (20)
20002990	MicroCable Plenum ENT-A OM4-24	OM4 (50/125)	24	0.14 (3.6)	7.4 (11.0)	22 (100)	7 (30)	1.2 (30)	0.8 (20)
20002919	MicroCable Plenum ENT-A OM4-48	OM4 (50/125)	48	0.15 (3.8)	9.4 (14.0)	22 (100)	7 (30)	1.2 (30)	0.8 (20)
20003341	MicroCable Plenum ENT-A OM4-72	OM4 (50/125)	72	0.18 (4.5)	15.0 (22.3)	22 (100)	7 (30)	3.6 (90)	1.8 (45)

Qualifications

GOVERNING BODY	STANDARD CODE	COMPONENT
Telcordia	GR-409-CORE	Fiber Optic Cable
RoHS	2015/863	Fiber Optic Cable
UL	1666 (OFNR)	Riser Cables
NEC	2005 Art 770.51 (B)	Riser Cables
NFPA	262 OFNP	Plenum Cables

Temperature Specifications

TEMPERATURE RANGE	
INSTALLATION	0°C to +70°C
OPERATING*	0°C to +70°C
STORAGE	-40°C to +75°C

*Not intended for outside plant access during operational use.

Contact AFL for packaging details or any further questions.

eABF® SWR® Enterprise Air-Jetted Fiber Cable

The AFL eABF SWR (SpiderWeb Ribbon®) is a new innovation that combines the best of ribbon fiber mass-fusion functionality and single fiber-bundle packing density to enterprise fiber optic structured cabling materials. The SWR fiber bundle used in this version of the eABF air-jetted fiber optic cable allows for the design of round, high-fiber density geometry yet offers the installer the ability to quickly and efficiently install MPO multi-fiber connectors or mass-fusion splicing without having to sort out and arrange individual fibers. In addition, because of SWR fiber binding system, the individual optical fibers can be easily separated and terminated as single fiber units.

The eABF SWR cable meets the interconnect standards of Telcordia GR-409 and is rated to meet NFPA/NEC flame-safety requirements as a stand-alone cable yet can be jetted thousands of feet in the Dura-Line FuturePath MicroDuct pathway system.

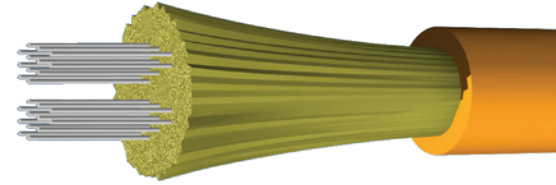

Features

- 24, 48, 72 and 144 fiber options increase design flexibility without increasing space or installation time (labor costs) requirements
- Riser and Plenum options for use in riser or plenum pathway environments (outside of micro-duct)
- Contains water-blocking components for additional fiber protection from accidental water exposure
- Innovative fiber-ribbon bonding allows for higher density cable than traditional flat, fiber-ribbon
- SpiderWeb Ribbon technology reduces cable diameter to improve pathway space and cooling channel efficiencies
- Cable can be routed within cable management pathways (outside of micro-duct)
- OM3, OM4 and single-mode optical fiber options which support easy migration to IEEE 802.3ba 40GbE and 100GbE applications
- Optimized for high-density terminations for excellent integration with MPO-based and mass-fusion spliced connectivity solutions
- Environment-safe materials reduces concern for handling of cables
- Cables can be de-installed and reused to meet LEED-design guidelines for green building initiatives

SWR Technology

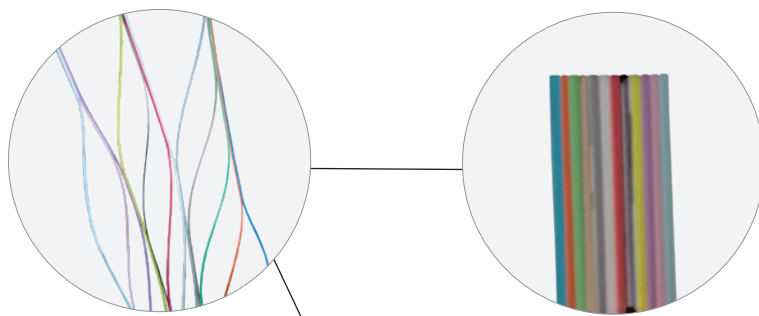

Cable Components

aramid yarn
coated fiber
outer jacket

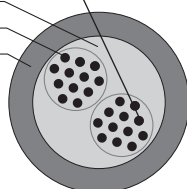

24 Fiber eABF SWR

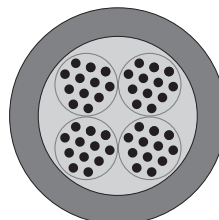

48 Fiber eABF SWR

continued
→

eABF® SWR® Enterprise Air-Jettted Fiber Cable

Ordering Information and Mechanical Data

DURA-LINE NO.	DESCRIPTION	FIBER TYPE	FIBER COUNT	NOMINAL DIAMETER		WEIGHT	MAXIMUM TENSILE LOAD lbs (N)		MINIMUM BEND RADIUS INCHES (MM)	
				Inches (mm)	lbs/1,000 ft (kg/km)		SHORT TERM	LONG TERM	SHORT TERM	LONG TERM
PLENUM										
20003524	MicroCable SWR Plenum ENT-A SMF-SWR-12	SMF-SWR	12	0.14 (3.5)	7.4 (11.0)	22 (100)	7 (30)	2.0 (56)	1.5 (35)	
20003525	MicroCable SWR Plenum ENT-A OM3-SWR-12	OM3-SWR	12	0.14 (3.5)	7.4 (11.0)	22 (100)	7 (30)	2.0 (56)	1.5 (35)	
20003526	MicroCable SWR Plenum ENT-A OM4-SWR-12	OM4-SWR	12	0.14 (3.5)	7.4 (11.0)	22 (100)	7 (30)	2.0 (56)	1.5 (35)	
20003374	MicroCable SWR Plenum ENT-A SMF-SWR-24	SMF-SWR	24	0.14 (3.5)	8.7 (12.9)	22 (100)	7 (30)	2.0 (56)	1.5 (35)	
20003375	MicroCable SWR Plenum ENT-A OM3-SWR-24	OM3-SWR	24	0.14 (3.5)	8.7 (12.9)	22 (100)	7 (30)	2.0 (56)	1.5 (35)	
20003376	MicroCable SWR Plenum ENT-A OM4-SWR-24	OM4-SWR	24	0.14 (3.5)	8.7 (12.9)	22 (100)	7 (30)	2.0 (56)	1.5 (35)	
20003306	MicroCable SWR Plenum ENT-A SMF-SWR-48	SMF-SWR	48	0.16 (4.0)	12 (17.9)	22 (100)	7 (30)	2.5 (60)	1.5 (35)	
20003307	MicroCable SWR Plenum ENT-A OM3-SWR-48	OM3-SWR	48	0.16 (4.0)	12 (17.9)	22 (100)	7 (30)	2.5 (60)	1.5 (35)	
20003308	MicroCable SWR Plenum ENT-A OM4-SWR-48	OM4-SWR	48	0.16 (4.0)	12 (17.9)	22 (100)	7 (30)	2.5 (60)	1.5 (35)	
20005465	MicroCable Plenum ENT-SWR SM-144 200 µm	SMF-SWR 200 µm	144	0.28 (7.2)	42 (62.5)	22 (100)	7 (30)	7 (160)	4 (80)	
RISER										
20003521	MicroCable SWR Riser ENT-A SMF-SWR-12	SMF-SWR	12	0.14 (3.5)	7.4 (11.0)	22 (100)	7 (30)	2.0 (56)	1.5 (35)	
20003522	MicroCable SWR Riser ENT-A OM3-SWR-12	OM3-SWR	12	0.14 (3.5)	7.4 (11.0)	22 (100)	7 (30)	2.0 (56)	1.5 (35)	
20003523	MicroCable SWR Riser ENT-A OM4-SWR-12	OM4-SWR	12	0.14 (3.5)	7.4 (11.0)	22 (100)	7 (30)	2.0 (56)	1.5 (35)	
20003425	MicroCable Riser ENT-SWR SM-24	SMF-SWR	24	0.14 (3.5)	8.7 (12.9)	22 (100)	7 (30)	2.0 (56)	1.5 (35)	
20003424	MicroCable Riser ENT-SWR OM3-24	OM3-SWR	24	0.14 (3.5)	8.7 (12.9)	22 (100)	7 (30)	2.0 (56)	1.5 (35)	
20003428	MicroCable Riser ENT-SWR OM4-24	OM4-SWR	24	0.14 (3.5)	8.7 (12.9)	22 (100)	7 (30)	2.0 (56)	1.5 (35)	
20003303	MicroCable Riser ENT-SWR SM-48	SMF-SWR	48	0.16 (4.0)	11 (16.4)	22 (100)	7 (30)	2.5 (60)	1.5 (35)	
20003304	MicroCable Riser ENT-SWR OM3-48	OM3-SWR	48	0.16 (4.0)	11 (16.4)	22 (100)	7 (30)	2.5 (60)	1.5 (35)	
20003305	MicroCable Riser ENT-SWR OM4-48	OM4-SWR	48	0.16 (4.0)	11 (16.4)	22 (100)	7 (30)	2.5 (60)	1.5 (35)	
20003446	MicroCable SWR Riser ENT-A OM3-SWR-72	OM3-SWR	72	0.18 (4.5)	16 (23.8)	22 (100)	7 (30)	2.7 (67)	1.8 (45)	
20003447	MicroCable SWR Riser ENT-A OM4-SWR-72	OM4-SWR	72	0.18 (4.5)	16 (23.8)	22 (100)	7 (30)	2.7 (67)	1.8 (45)	
20003448	MicroCable SWR Riser ENT-4 SMF-SWR-72	SMF-SWR	72	0.18 (4.5)	16 (23.8)	22 (100)	7 (30)	2.7 (67)	1.8 (45)	
20003882	MicroCable Riser ENT-SWR SM-144	SMF-SWR	144	0.28 (7.2)	30 (44.6)	22 (100)	7 (30)	7 (160)	4 (80)	

Optical Specifications

FIBER TYPE	MAXIMUM ATTENUATION (dB/km)				OVERFILL LAUNCH MIN. BANDWIDTH (MHz•km)		EMBc (MHz•km)	GIGABIT ETHERNET MAX. LINK DISTANCE (Meters)		10 GIGABIT ETHERNET MAX. LINK DISTANCE (Meters)	
	850 nm	1300 nm	1310 nm	1550 nm	850 nm	1300 nm		850 nm	1300 nm	850 nm	1300 nm
OM3	3.0	1.2	N/A	N/A	1500	500	2000	1000	550	300	N/A
OM4	3.0	1.2	N/A	N/A	3500	550	4700	1040	550	550	N/A
OS2	N/A	N/A	0.5	0.5	N/A	N/A	N/A	N/A	N/A	N/A	N/A

Qualifications

GOVERNING BODY	STANDARD CODE	COMPONENT
Telcordia	GR-409-CORE	Fiber Optic Cable
RoHS	2015/863	Fiber Optic Cable
UL	1666 (ONFR)	Riser Cables
NEC	2005 Art 770.51 (B)	Riser Cables
NFPA	262 OFNP	Plenum Cables

Temperature Specifications

TEMPERATURE RANGE	
INSTALLATION	0°C to +70°C
OPERATING*	0°C to +70°C
STORAGE	-40°C to +75°C

*Not intended for outside plant access during operational use.

Contact AFL for further details.

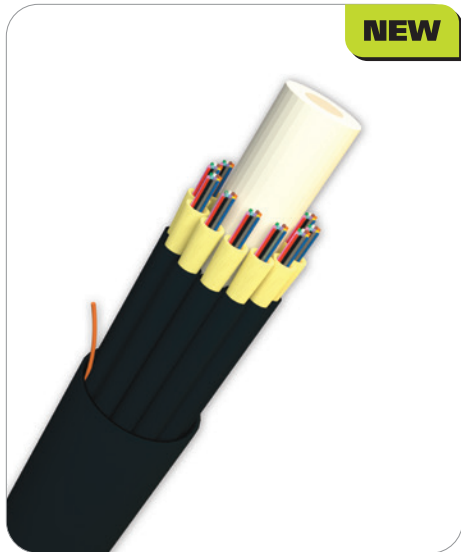

Indoor/Outdoor Riser Sub-unitized MicroCore® Cable

AFL now offers high fiber count Indoor/Outdoor MicroCore Cables. Waterblocked sub-units are helically stranded to provide sub-unitized cables ranging from 24 to 288 fiber counts. These cables are OFNR listed for use in indoor and indoor/outdoor applications. Both the sub-unit jackets and outer sheath contain a UV stabilizer and anti-fungus protection for use in outdoor applications.

Features

- Available with 24 to 288 fibers
- Water-blocked sub-units
- Moisture-resistant, fungus-resistant and UV-resistant sub-unit jackets and outer sheath

Applications

- ONFR inside plant and outside plant environments

Cable Components

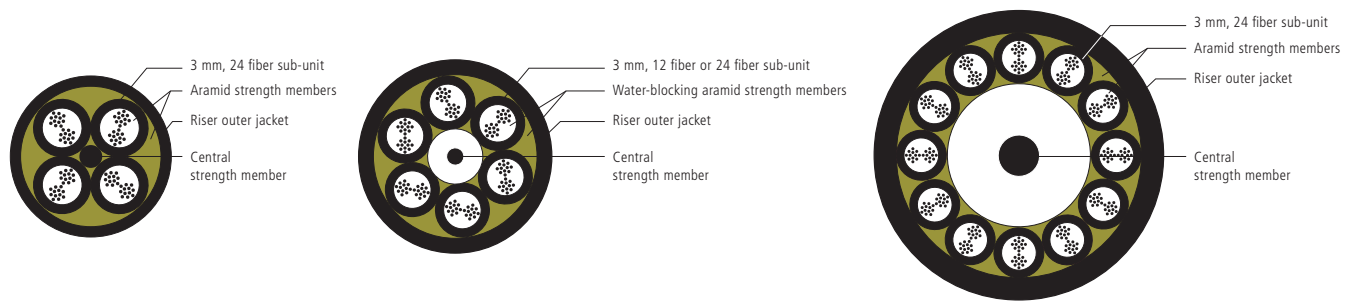

Fiber Specifications

CORE SIZE/FIBER TYPE	ISO/IEC	MAXIMUM ATTENUATION (dB/km)			OVERFILL LAUNCH MIN. BANDWIDTH (MHz•km)		EMB _c (MHz•km)	GIGABIT ETHERNET MAX. LINK DISTANCE (meters)		10 GIGABIT ETHERNET MAX. LINK DISTANCE (meters)	
		850 nm	1300 nm	1550 nm	850 nm	1300 nm		850 nm	1300 nm	850 nm	1300 nm
		(6) 62.5 Giga-Link™ 300	OM1	3.5	1.2	N/A		200	600	N/A	300
(5) 50 Giga-Link™ 600	OM2	3.5	1.5	N/A	500	500	N/A	600	600	82	—
(L) 50 Laser-Link 300	OM3	3.0	1.2	N/A	1,500	500	2,000	1,000	550	300	—
(C) 50 Laser-Link 550	OM4	3.0	1.2	N/A	3,500	500	4,700	1,040	550	550	—
(W) AFL Wideband Multimode	OM5	3.0	1.2	N/A	3,500	500	4,700	1,040	550	550	—
(9) Single-mode (ITU G.652.D/G.657.A1)	OS2	N/A	0.5	0.5	N/A	N/A	N/A	N/A	5,000	N/A	10,000



Indoor/Outdoor Riser Sub-unitized MicroCore® Cable

Mechanical Data—Non-Armored

CABLE TYPE	NO. OF SUBS	NO. OF FILLERS	NOMINAL DIAMETER inches (mm)	WEIGHT lbs/1000 ft (kg/km)	TENSION lbs (N)		BENDING RADIUS inches (cm)	
					INSTALLATION	LONG TERM	INSTALLATION	LONG TERM
12 Fiber Subunit	2	2	0.38 (9.7)	52 (78)	300 (1320)	90 (400)	5.7 (14.6)	3.8 (9.7)
	4	0	0.38 (9.7)	54 (80)	300 (1320)	90 (400)	5.7 (14.6)	3.8 (9.7)
	6	0	0.46 (11.6)	77 (115)	300 (1320)	90 (400)	6.9 (17.4)	4.6 (11.6)
	8	0	0.54 (13.7)	105 (155)	300 (1320)	90 (400)	8.1 (20.6)	5.4 (13.7)
	12	0	0.68 (17.3)	250 (370)	300 (1320)	90 (400)	10.2 (26.0)	6.8 (17.3)
24 Fiber Subunit	1	3	0.38 (9.7)	53 (79)	300 (1320)	90 (400)	5.7 (14.6)	3.8 (9.7)
	2	2	0.38 (9.7)	54 (80)	300 (1320)	90 (400)	5.7 (14.6)	3.8 (9.7)
	3	1	0.38 (9.7)	55 (82)	300 (1320)	90 (400)	5.7 (14.6)	3.8 (9.7)
	4	0	0.38 (9.7)	56 (83)	300 (1320)	90 (400)	5.7 (14.6)	3.8 (9.7)
	6	0	0.46 (11.6)	81 (120)	300 (1320)	90 (400)	6.9 (17.4)	4.6 (11.6)
	12	0	0.68 (17.3)	257 (380)	300 (1320)	90 (400)	10.2 (26.0)	6.8 (17.3)

Ordering Information—Non-Armored

CABLE TYPE	NO. OF FIBERS	NO. OF SUBS	NO. OF FILLERS	AFL NO.
				BARE FIBER
12 Fiber Subunit	24	2	2	QR024*3018#B:C4C
	48	4	0	QR048*3018#B:C4C
	72	6	0	QR072*3018#B:C6C
	96	8	0	QR096*3018#B:C8C
	144	12	0	QR144*3018#B:CCC
24 Fiber Subunit	24	1	3	QR024*3018#B:O4C
	48	2	2	QR048*3018#B:O4C
	72	3	1	QR072*3018#B:O4C
	96	4	0	QR096*3018#B:O4C
	144	6	0	QR144*3018#B:O6C
	288	12	0	QR288*3018#B:OCC

* Fiber Types – Replace asterisk (*) in AFL number above with number in the Fiber Specifications table on previous page.
 # Subunit Jacket Color – Replace hashtag (#) in AFL number with number in the Cable Jacket Color table at right.
 ** Item numbers represent AFL standard print and Black outer jacket. All jacket colors are UV stable and contain anti-fungal additive. For best performance, AFL recommends Black Outer Jacket.

Cable Jacket Color Options

1 - Blue	8 - Black
2 - Orange	9 - Yellow (SM)
3 - Green	A - Violet
4 - Brown	B - Rose
5 - Slate	C - Aqua (OM3 and OM4)
6 - White	K - Erika Violet (OM4)
7 - Red	L - Lime

Qualifications

GOVERNING BODY	STANDARD CODE	COMPONENT
Telcordia	GR-20-CORE GR-409-CORE	Water-Blocked Cabled Buffer Tube Core Sub-units
EIA/TIA	598-A	Sub-units
ICEA	S-104-696	Sub-units
RoHS	2002/95/EC	Cable

Temperature Specifications

TEMPERATURE RANGE	
INSTALLATION	-10°C to +70°C
OPERATION	-40°C to +70°C
STORAGE	-40°C to +70°C

Contact AFL for further details.

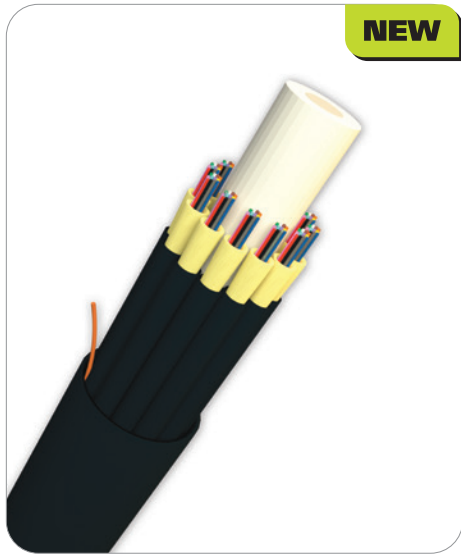

Indoor/Outdoor Riser Sub-unitized MicroCore® Cable with SpiderWeb Ribbon® Technology

AFL now offers high fiber count Indoor/Outdoor MicroCore Cables with SpiderWeb Ribbon (SWR®) technology. Waterblocked sub-units are helically stranded to provide sub-unitized cables ranging from 24 to 288 fiber counts. These cables are OFNR listed for use in indoor and indoor/outdoor applications. Both the sub-unit jackets and outer sheath contain a UV stabilizer and anti-fungus protection for use in outdoor applications.

Features

- Available with 24 to 288 fibers
- Water-blocked sub-units
- Moisture-resistant, fungus-resistant and UV-resistant sub-unit jackets and outer sheath

Applications

- ONFR inside plant and outside plant environments

Cable Components

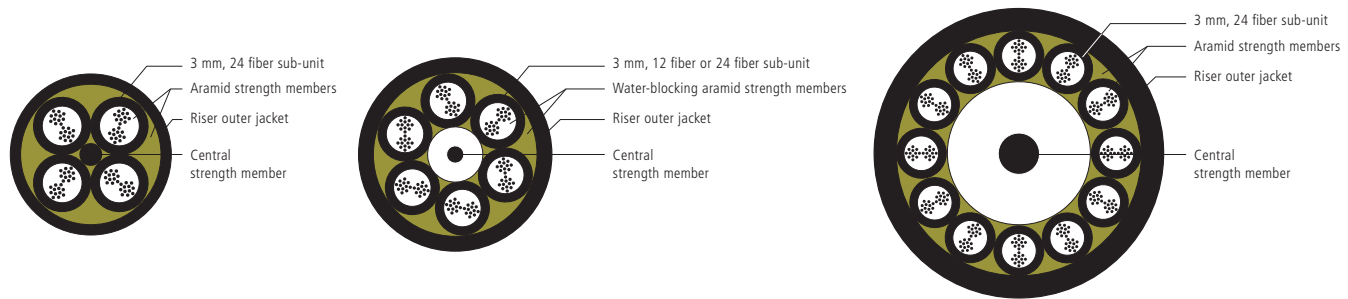

SWR Fiber Specifications

CORE SIZE/FIBER TYPE	ISO/IEC	MAXIMUM ATTENUATION (dB/km)			OVERFILL LAUNCH MIN. BANDWIDTH (MHz•km)		EMB _c (MHz•km)	GIGABIT ETHERNET MAX. LINK DISTANCE (meters)		10 GIGABIT ETHERNET MAX. LINK DISTANCE (meters)	
		850 nm	1300 nm	1550 nm	850 nm	1300 nm		850 nm	1300 nm	850 nm	1300 nm
(P) AFL Bend-Insensitive Single-mode (ITU G.652.D/G.657.A1)	OS2	N/A	0.5	0.5	N/A	N/A	N/A	N/A	5,000	N/A	10,000





Indoor/Outdoor Riser Sub-unitized MicroCore® Cable with SpiderWeb Ribbon® Technology

Mechanical Data—Non-Armored

CABLE TYPE	NO. OF SUBS	NO. OF FILLERS	NOMINAL DIAMETER inches (mm)	WEIGHT lbs/1000 ft (kg/km)	TENSION lbs (N)		BENDING RADIUS inches (cm)	
					INSTALLATION	LONG TERM	INSTALLATION	LONG TERM
12 Fiber Subunit	2	2	0.38 (9.7)	52 (78)	300 (1320)	90 (400)	5.7 (14.6)	3.8 (9.7)
	4	0	0.38 (9.7)	54 (80)	300 (1320)	90 (400)	5.7 (14.6)	3.8 (9.7)
	6	0	0.46 (11.6)	77 (115)	300 (1320)	90 (400)	6.9 (17.4)	4.6 (11.6)
	8	0	0.54 (13.7)	105 (155)	300 (1320)	90 (400)	8.1 (20.6)	5.4 (13.7)
	12	0	0.68 (17.3)	250 (370)	300 (1320)	90 (400)	10.2 (26.0)	6.8 (17.3)
24 Fiber Subunit	1	3	0.38 (9.7)	53 (79)	300 (1320)	90 (400)	5.7 (14.6)	3.8 (9.7)
	2	2	0.38 (9.7)	54 (80)	300 (1320)	90 (400)	5.7 (14.6)	3.8 (9.7)
	3	1	0.38 (9.7)	55 (82)	300 (1320)	90 (400)	5.7 (14.6)	3.8 (9.7)
	4	0	0.38 (9.7)	56 (83)	300 (1320)	90 (400)	5.7 (14.6)	3.8 (9.7)
	6	0	0.46 (11.6)	81 (120)	300 (1320)	90 (400)	6.9 (17.4)	4.6 (11.6)
	12	0	0.68 (17.3)	257 (380)	300 (1320)	90 (400)	10.2 (26.0)	6.8 (17.3)

Ordering Information—Non-Armored

CABLE TYPE	NO. OF FIBERS	NO. OF SUBS	NO. OF FILLERS	AFL NO.
				SINGLE-MODE SWR*
12 Fiber Subunit	24	2	2	QR024P30189R:C4C
	48	4	0	QR048P30189R:C4C
	72	6	0	QR072P30189R:C6C
	96	8	0	QR096P30189R:C8C
	144	12	0	QR144P30189R:CCC
24 Fiber Subunit	24	1	3	QR024P30189R:O4C
	48	2	2	QR048P30189R:O4C
	72	3	1	QR072P30189R:O4C
	96	4	0	QR096P30189R:O4C
	144	6	0	QR144P30189R:O6C
	288	12	0	QR288P30189R:OCC

Cable Jacket Color Options

1 - Blue	8 - Black
2 - Orange	9 - Yellow (SM)
3 - Green	A - Violet
4 - Brown	B - Rose
5 - Slate	C - Aqua (OM3 and OM4)
6 - White	K - Erika Violet (OM4)
7 - Red	L - Lime

* Item numbers represent AFL standard print, Black Outer Jacket and Yellow Subunits. All jacket colors are UV stable and contain anti-fungal additive. For best performance, AFL recommends Black Outer Jacket.

Qualifications

GOVERNING BODY	STANDARD CODE	COMPONENT
Telcordia	GR-20-CORE GR-409-CORE	Water-Blocked Cabled Buffer Tube Core Sub-units
EIA/TIA	598-A	Sub-units
ICEA	S-104-696	Sub-units
RoHS	2002/95/EC	Cable

Temperature Specifications

TEMPERATURE RANGE	
INSTALLATION	0°C to +60°C
OPERATION	-20°C to +70°C
STORAGE	-40°C to +70°C

Contact AFL for further details.



MDU Drop Cable

AFL MDU Drop cables are light weight, robust products specifically designed for deployment in FTTx environments available in both Black and White outer jacket colors. Products feature UV-Resistant and Anti-fungal outer jacket, with water-blocking aramid yarns in the core for additional network protection.

Features

- Water blocked cable core helps ensure any damage will be limited in the core of the cable
- Outer jacket is moisture-resistant, fungus-resistant and UV resistant for outdoor use
- Riser rating enables this cable to be used in multiple environments: Riser, general inside plant and outside plant

Cable Components

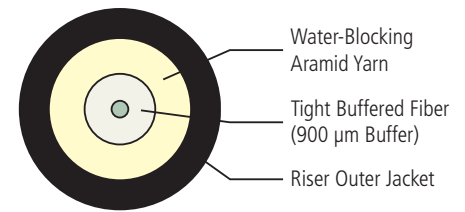

Ordering Information

DESCRIPTION	FIBER GRADE		
	ITU G.652.D / G.657.A1	ITU G.657.A2/B2	ITU G.657.B3
1F 3.0 mm - Black jacket	KR0019301801-VZ	KR001X301801-VZ-A2	KR001X301801-VZ-B3
1F 3.0 mm - White jacket	KR0019301601-VZ	KR001X301601-VZ-A2	KR001X301601-VZ-B3
1F 4.8 mm - Black jacket	KR0019481801-VZ	KR001X481801-VZ-A2	KR001X481801-VZ-B3
1F 4.8 mm - White jacket	KR0019481601-VZ	KR001X481601-VZ-A2	KR001X481601-VZ-B3
2F 4.8 mm - Black jacket	KR0029481801-VZ	KR002X481801-VZ-A2	KR002X481801-VZ-B3
2F 4.8 mm - White jacket	KR0029481601-VZ	KR002X481601-VZ-A2	KR002X481601-VZ-B3

Mechanical Information

FIBER COUNT	NOMINAL DIAMETER inches (mm)	WEIGHT lbs/1000 ft (kg/km)	TENSION lbs (N)		BENDING RADIUS inches (cm)	
			INSTALL	LONGTERM	INSTALL	LONGTERM
1F 3.0 mm	0.12 (3.0)	4.8 (7.1)	100 (440)	40 (200)	1.8 (4.5)	1.2 (3.0)
1F 4.8 mm	0.19 (4.8)	14 (21)	100 (440)	40 (200)	2.8 (7.2)	1.9 (4.8)
2F 4.8 mm	0.19 (4.8)	14 (21)	100 (440)	40 (200)	2.8 (7.2)	1.9 (4.8)

Fiber Specifications

CORE SIZE/FIBER TYPE	MAXIMUM ATTENUATION (dB/km)		GIGABIT ETHERNET MAX. LINK DISTANCE (meters)		10 GIGABIT ETHERNET MAX. LINK DISTANCE (meters)	
	1310 nm	1550 nm	1310 nm	1550 nm	1310 nm	1550 nm
(9) Single-mode (ITU G.652.D/G.657.A1)	0.5	0.5	N/A	5,000	N/A	10,000
(X, -A2) ITU G.657.A2/B2	0.5	0.5	N/A	5,000	N/A	10,000
(X, -B3) ITU G.657.B3	0.5	0.5	N/A	5,000	N/A	10,000

Qualifications

GOVERNING BODY	STANDARD CODE
Telcordia	GR-409 Issue 2
ICEA	ICEA-S-104-696, ICEA S-115-730
Verizon	TPR 9424 Issue 3*

* 4.8 mm OD design with ITU G.657.B3 grade fiber required to meet all requirements

Temperature Specifications

TEMPERATURE RANGE	
OPERATION	-40°C to +70°C
STORAGE	-40°C to +70°C
INSTALLATION	-20°C to +70°C

Contact AFL for further details.

Premise Cable

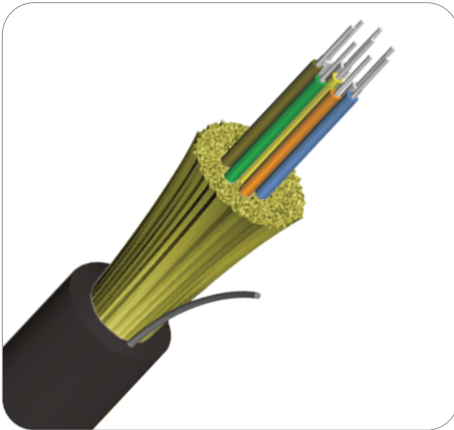

Indoor/Outdoor Riser Tight Buffered Cable

Indoor/Outdoor Tight Buffered cables are specified for campus network cabling between buildings where interbuilding lengths are short enough that the installer can recognize savings from the lower costs of terminating tight buffered cables.

For indoor applications the cable is OFNR listed. For outdoor applications the cable is manufactured with an outer jacket that incorporates a UV stabilizer for protection against exposure to the sun plus an anti-fungus protection for use in underground applications.

Features

- Available with 2 to 24 fibers
- 12-fiber water-blocked sub-units
- Moisture-resistant, fungus-resistant and UV-resistant outer jacket

Applications

- ONFR inside plant and outside plant environments
- Campus LAN
- Building Interconnections
- Mining

Cable Components

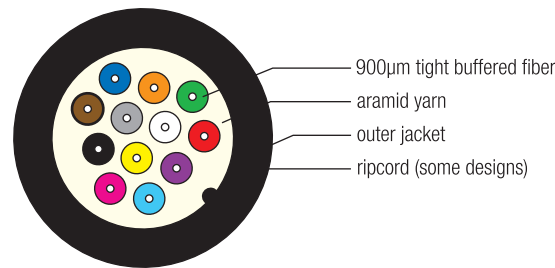

Fiber Specifications

CORE SIZE/FIBER TYPE	ISO/IEC	MAXIMUM ATTENUATION (dB/km)			OVERFILL LAUNCH MIN. BANDWIDTH (MHz•km)		EMB _c (MHz•km)	GIGABIT ETHERNET MAX. LINK DISTANCE (meters)		10 GIGABIT ETHERNET MAX. LINK DISTANCE (meters)	
		850 nm	1300 nm	1550 nm	850 nm	1300 nm		850 nm	1300 nm	850 nm	1300 nm
		(6) 62.5 Giga-Link™ 300	OM1	3.5	1.2	N/A		200	600	N/A	300
(5) 50 Giga-Link™ 600	OM2	3.5	1.5	N/A	500	500	N/A	600	600	82	—
(L) 50 Laser-Link 300	OM3	3.0	1.2	N/A	1,500	500	2,000	1,000	550	300	—
(C) 50 Laser-Link 550	OM4	3.0	1.2	N/A	3,500	500	4,700	1,040	550	550	—
(W) AFL Wideband Multimode	OM5	3.0	1.2	N/A	3,500	500	4,700	1,040	550	550	—
(9) Single-mode (ITU G.652.D/G.657.A1)	OS2	N/A	0.5	0.5	N/A	N/A	N/A	N/A	5,000	N/A	10,000



STOCK ITEM

Indoor/Outdoor Riser Tight Buffered Cable

Mechanical Data

CABLE TYPE	AFL NO.	FIBER COUNT	NOMINAL DIAMETER	WEIGHT	TENSION		BENDING RADIUS	
					lbs (N)		inches (cm)	
	RISER		inches (mm)	lbs/1000 ft (kg/km)	INSTALLATION	LONG TERM	INSTALLATION	LONG TERM
Indoor/Outdoor Tight Buffered Cable	KR002★481#01	2	0.19 (4.8)	14 (21)	150 (660)	45 (198)	2.8 (7.2)	1.9 (4.8)
	KR004★481#01	4	0.19 (4.8)	15 (23)	150 (660)	45 (198)	2.8 (7.2)	1.9 (4.8)
	KR006★531#01	6	0.21 (5.3)	19 (28)	150 (660)	45 (198)	3.1 (8.0)	2.1 (5.3)
	KR008★561#01	8	0.22 (5.6)	23 (33)	150 (660)	45 (198)	3.3 (8.4)	2.2 (5.6)
	KR012★651#01	12	0.26 (6.5)	26 (38)	150 (660)	45 (198)	3.5 (9.0)	2.6 (6.5)
	KR018★801#01	18	0.31 (8.0)	40 (59)	300 (1320)	90 (396)	4.7 (12.0)	3.1 (8.0)
	KR024★871#01	24	0.33 (8.7)	46 (69)	300 (1320)	90 (396)	5.2 (13.1)	3.4 (8.7)

★ Fiber Types – Replace asterisk (★) in AFL number with number in the Fiber Specifications table on previous page.

Outer Jacket Color – Replace hashtag (#) in AFL number with number in the Cable Jacket Color table below.

Cable Jacket Color* Options

1 - Blue	8 - Black
2 - Orange	9 - Yellow
3 - Green	A - Violet
4 - Brown	B - Rose
5 - Slate	C - Aqua
6 - White	K - Erika Violet (RAL 4003)
7 - Red	

* All jacket colors are UV stable and contain anti-fungal additive.
For best performance, AFL recommends Black Outer Jacket.

Qualifications

GOVERNING BODY	STANDARD CODE	COMPONENT
Telcordia	GR-20-CORE GR-409-CORE	Water-Blocked Cabled Buffer Tube Core Sub-units
EIA/TIA	598-A	Sub-units
ICEA	S-104-696	Sub-units
MSHA		
RoHS	2002/95/EC	Cable

Temperature Specifications

TEMPERATURE RANGE	
INSTALLATION	-20°C to +75°C
OPERATION	-40°C to +75°C
STORAGE	-40°C to +75°C

Contact AFL for further details.

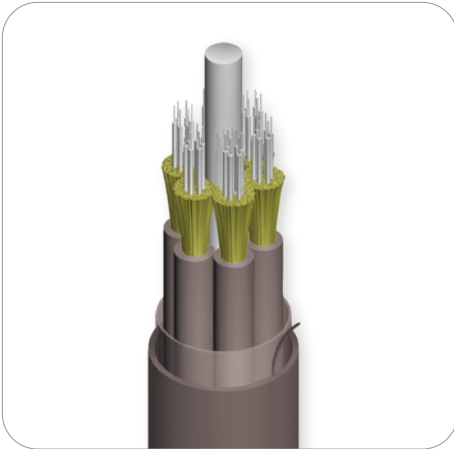

Indoor/Outdoor Multi-unit Riser Tight Buffered Cable

AFL now offers high fiber count Indoor/Outdoor Riser Cables. Waterblocked 12-fiber sub-units are helically stranded to provide sub-unitized cables ranging from 24 to 72 fiber counts. These cables are OFNR listed for indoor applications. Both the sub-unit jackets and outer sheath contain a UV stabilizer and anti-fungus protection for use in outdoor applications. Sub-units contain a water-swellable aramid and 12 tight buffered fibers.

Features

- Available with 24 to 72 fibers
- 12-fiber water-blocked sub-units
- Moisture-resistant, fungus-resistant and UV-resistant sub-unit jackets and outer sheath

Applications

- ONFR inside plant and outside plant environments

Cable Components

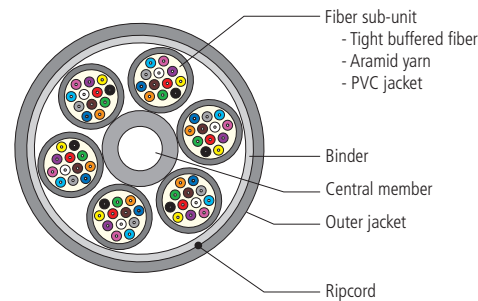

Fiber Specifications

CORE SIZE/FIBER TYPE	ISO/IEC	MAXIMUM ATTENUATION (dB/km)			OVERFILL LAUNCH MIN. BANDWIDTH (MHz•km)		EMB _c (MHz•km)	GIGABIT ETHERNET MAX. LINK DISTANCE (meters)		10 GIGABIT ETHERNET MAX. LINK DISTANCE (meters)	
		850 nm	1300 nm	1550 nm	850 nm	1300 nm		850 nm	1300 nm	850 nm	1300 nm
(6) 62.5 Giga-Link™ 300	OM1	3.5	1.2	N/A	200	600	N/A	300	550	32	—
(5) 50 Giga-Link™ 600	OM2	3.5	1.5	N/A	500	500	N/A	600	600	82	—
(L) 50 Laser-Link 300	OM3	3	1.2	N/A	1,500	500	2,000	1,000	550	300	—
(C) 50 Laser-Link 550	OM4	3	1.2	N/A	3,500	500	4,700	1,040	550	550	—
(W) AFL Wideband Multimode	OM5	3	1.2	N/A	3,500	500	4,700	1,040	550	550	—
(9) Single-mode (ITU G.652.D/G.657.A1)	OS2	N/A	0.5	0.5	N/A	N/A	N/A	N/A	5,000	N/A	10,000



Indoor/Outdoor Multi-unit Riser Tight Buffered Cable

Mechanical Data

CABLE TYPE	AFL NO.	FIBER COUNT	NOMINAL DIAMETER	WEIGHT	TENSION		BENDING RADIUS	
					lbs (N)		inches (cm)	
	RISER		inches (mm)	lbs/1000 ft (kg/km)	INSTALLATION	LONG TERM	INSTALLATION	LONG TERM
Indoor/Outdoor Tight Buffered Cable	KR024★611##1	24	0.67 (16.9)	169 (252)	300 (1320)	90 (396)	10.0 (25.3)	6.7 (16.9)
	KR036★611##1	36	0.67 (16.9)	178 (265)	300 (1320)	90 (396)	10.0 (25.3)	6.7 (16.9)
	KR048★611##1	48	0.67 (16.9)	187 (278)	300 (1320)	90 (396)	10.0 (25.3)	6.7 (16.9)
	KR060★611##1	60	0.76 (19.2)	197 (293)	300 (1320)	90 (396)	11.3 (28.8)	7.6 (19.2)
	KR072★611##1	72	0.81 (20.7)	233 (346)	300 (1320)	90 (396)	12.2 (31.0)	8.1 (20.7)

★ Fiber Types – Replace asterisk (★) in AFL number with number in the Fiber Specifications table on previous page.

Outer Jacket Color – Replace hashtag (#) in AFL number with number in the Cable Jacket Color table below.

Cable Jacket Color Options

1 - Blue	8 - Black
2 - Orange	9 - Yellow
3 - Green	A - Violet
4 - Brown	B - Rose
5 - Slate	C - Aqua
6 - White	K - Erika Violet (RAL 4003)
7 - Red	

Qualifications

GOVERNING BODY	STANDARD CODE	COMPONENT
Telcordia	GR-20-CORE GR-409-CORE	Water-Blocked Cabled Buffer Tube Core Sub-units
EIA/TIA	598-A	Sub-units
ICEA	S-104-696	Sub-units
RoHS	2002/95/EC	Cable

Temperature Specifications

TEMPERATURE RANGE	
INSTALLATION	-20°C to +75°C
OPERATION	-40°C to +75°C
STORAGE	-40°C to +75°C

Contact AFL for further details.

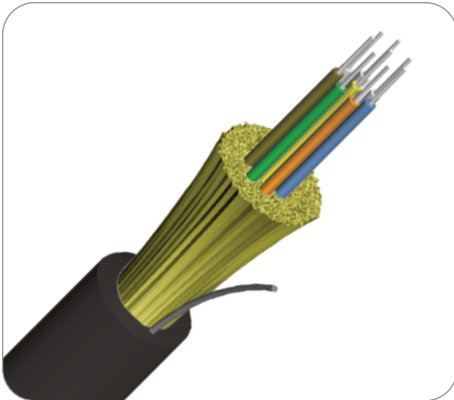

Indoor/Outdoor Plenum Distribution Cable

Indoor/Outdoor Plenum Distribution cables are specified for campus network cabling between buildings where interbuilding lengths are short enough that the installer can recognize savings from the lower costs of terminating tight buffered cables.

For indoor applications the cable is ONFP listed. For outdoor applications the cable is manufactured with an outer jacket that incorporates a UV stabilizer for protection against exposure to the sun plus an anti-fungus protection for use in underground applications.

Features

- Available with 2 to 24 fibers
- Water-blocked jacket protects fibers
- Moisture-resistant, fungus-resistant and UV-resistant outer jacket

Applications

- ONFP inside plant and outside plant environments
- Underground applications
- Building Interconnections (Campus LAN)

Cable Components

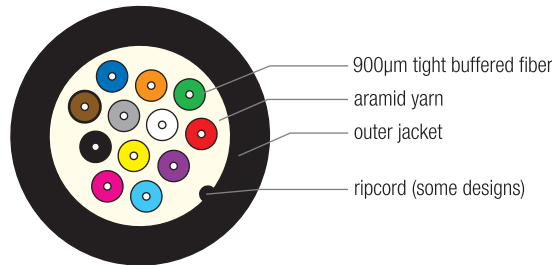

Fiber Specifications

CORE SIZE/FIBER TYPE	ISO/IEC	MAXIMUM ATTENUATION (dB/km)			OVERFILL LAUNCH MIN. BANDWIDTH (MHz•km)		EMB _c (MHz•km)	GIGABIT ETHERNET MAX. LINK DISTANCE (meters)		10 GIGABIT ETHERNET MAX. LINK DISTANCE (meters)	
		850 nm	1300 nm	1550 nm	850 nm	1300 nm		850 nm	1300 nm	850 nm	1300 nm
(6) 62.5 Giga-Link™ 300	OM1	3.5	1.2	N/A	200	600	N/A	300	550	32	—
(5) 50 Giga-Link™ 600	OM2	3.5	1.5	N/A	500	500	N/A	600	600	82	—
(L) 50 Laser-Link 300	OM3	3	1.2	N/A	1,500	500	2,000	1,000	550	300	—
(C) 50 Laser-Link 550	OM4	3	1.2	N/A	3,500	500	4,700	1,040	550	550	—
(W) AFL Wideband Multimode	OM5	3	1.2	N/A	3,500	500	4,700	1,040	550	550	—
(9) Single-mode (ITU G.652.D/G.657.A1)	OS2	N/A	0.5	0.5	N/A	N/A	N/A	N/A	5,000	N/A	10,000



Indoor/Outdoor Plenum Distribution Cable

Mechanical Data

AFL NO.	FIBER COUNT	DIAMETER inches (mm)	WEIGHT	TENSILE STRENGTH lbs (N)		BEND RADIUS inches (cm)	
			lbs/1000ft (kg/km)	INSTALLATION	LONG TERM	INSTALLATION	LONG TERM
KQ002★461#01	2	0.18 (4.6)	15 (22)	150 (667)	45 (200)	2.7 (6.9)	1.8 (4.6)
KQ004★501#01	4	0.20 (5.0)	17 (26)	150 (667)	45 (200)	3.0 (7.5)	2.0 (5.0)
KQ006★541#01	6	0.21 (5.4)	20 (30)	150 (667)	45 (200)	3.2 (8.1)	2.1 (5.4)
KQ012★611#01	12	0.24 (6.1)	27 (40)	150 (667)	45 (200)	3.6 (9.1)	2.4 (6.1)
KQ024★791#01	24	0.31 (7.9)	46 (69)	150 (667)	45 (200)	4.7 (11.9)	3.1 (7.9)

★ Fiber Types – Replace asterisk (★) in AFL number with number in the Fiber Specifications table on previous page.

Outer Jacket Color – Replace hashtag (#) in AFL number with number in the Cable Jacket Color table below.

Cable Jacket Color Options

1 - Blue	8 - Black
2 - Orange	9 - Yellow
3 - Green	A - Violet
4 - Brown	B - Rose
5 - Slate	C - Aqua
6 - White	K - Erika Violet (RAL 4003)
7 - Red	

Qualifications

GOVERNING BODY	STANDARD CODE	COMPONENT
Telcordia	GR-20-CORE GR-409-CORE	Water-Blocked Cabled Buffer Tube Core Weatherized Cable
EIA/TIA	568	Cable
ICEA	S-104-696	Cable
RoHS	REACH	Cable

Temperature Specifications

TEMPERATURE RANGE	
INSTALLATION	0°C to +70°C
OPERATION	-40°C to +70°C
STORAGE	-40°C to +70°C

Contact AFL for further details.

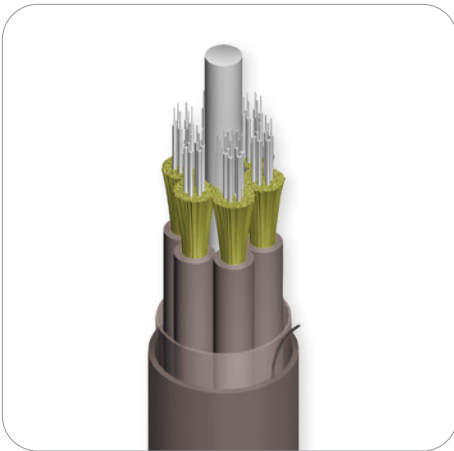

Indoor/Outdoor Multi-unit Plenum Tight Buffered Cable

AFL now offers high fiber count Indoor/Outdoor Plenum Cables. Designs are based on water-blocked 12-fiber sub-units that are helically stranded to provide sub-unitized cables ranging from 36 to 72 fiber counts. These cables are OFNP listed for indoor and indoor/outdoor applications. Both the sub-unit jackets and outer sheath contain a UV stabilizer and anti-fungus protection for use in outdoor applications. Sub-units contain a water-swallowable aramid and 12 tight buffered fibers.

Features

- Available with 36 to 72 fibers
- 12-fiber water-blocked sub-units
- Moisture-resistant, fungus-resistant and UV-resistant outer jacket

Applications

- ONFP inside plant and outside plant environments

Cable Components

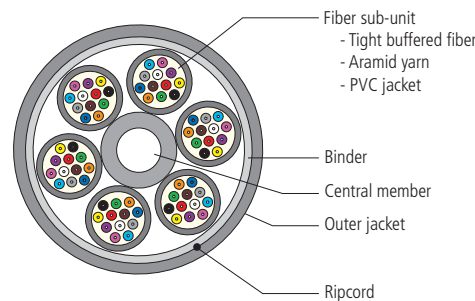

Fiber Specifications

CORE SIZE/FIBER TYPE	ISO/IEC	MAXIMUM ATTENUATION (dB/km)			OVERFILL LAUNCH MIN. BANDWIDTH (MHz•km)		EMB _c (MHz•km)	GIGABIT ETHERNET MAX. LINK DISTANCE (meters)		10 GIGABIT ETHERNET MAX. LINK DISTANCE (meters)	
		850 nm	1300 nm	1550 nm	850 nm	1300 nm		850 nm	1300 nm	850 nm	1300 nm
(6) 62.5 Giga-Link™ 300	OM1	3.5	1.2	N/A	200	600	N/A	300	550	32	—
(5) 50 Giga-Link™ 600	OM2	3.5	1.5	N/A	500	500	N/A	600	600	82	—
(L) 50 Laser-Link 300	OM3	3	1.2	N/A	1,500	500	2,000	1,000	550	300	—
(C) 50 Laser-Link 550	OM4	3	1.2	N/A	3,500	500	4,700	1,040	550	550	—
(W) AFL Wideband Multimode	OM5	3	1.2	N/A	3,500	500	4,700	1,040	550	550	—
(9) Single-mode (ITU G.652.D/G.657.A1)	OS2	N/A	0.5	0.5	N/A	N/A	N/A	N/A	5,000	N/A	10,000



Indoor/Outdoor Multi-unit Plenum Tight Buffered Cable

Mechanical Data

CABLE TYPE	AFL NO.	FIBER COUNT	NOMINAL DIAMETER	WEIGHT	TENSION		BENDING RADIUS	
	PLENUM		inches (mm)	lbs/1000 ft (kg/km)	lbs (N)		inches (cm)	
			INSTALLATION	LONG TERM	INSTALLATION	LONG TERM		
Indoor/Outdoor Tight Buffered Cable	KQ036★591##1	36	0.62 (15.7)	155 (225)	300 (1320)	90 (396)	9.3 (23.6)	6.2 (15.7)
	KQ048★591##1	48	0.68 (17.2)	190 (280)	300 (1320)	90 (396)	10.2 (25.8)	6.8 (17.2)
	KQ060★591##1	60	0.75 (19.0)	240 (350)	300 (1320)	90 (396)	11.3 (28.5)	7.5 (19.0)
	KQ072★591##1	72	0.82 (20.8)	290 (430)	300 (1320)	90 (396)	12.3 (31.2)	8.2 (20.8)

★ Fiber Types – Replace asterisk (★) in AFL number with number in the Fiber Specifications table on previous page.

Outer Jacket Color – Replace hashtag (#) in AFL number with number in the Cable Jacket Color table below.

Cable Jacket Color Options

1 - Blue	8 - Black
2 - Orange	9 - Yellow
3 - Green	A - Violet
4 - Brown	B - Rose
5 - Slate	C - Aqua
6 - White	K - Erika Violet (RAL 4003)
7 - Red	

Qualifications

GOVERNING BODY	STANDARD CODE	COMPONENT
Telcordia	GR-20-CORE	Water-Blocked Cabled Buffer Tube Core
EIA/TIA	598-A/GR-409-CORE	Sub-units
ICEA	S-104-696	Sub-units
RoHS	2002/95/EC	Cable

Temperature Specifications

TEMPERATURE RANGE	
INSTALLATION	-20°C to +75°C
OPERATION	-40°C to +75°C
STORAGE	-40°C to +75°C

Contact AFL for further details.

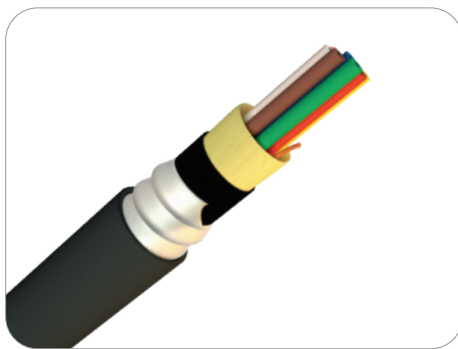

Indoor/Outdoor Armored Tight Buffered Circular Premise Cable

Indoor/Outdoor Armored Tight Buffered CPC Cables incorporate two to 72 fiber count CPC cables in a jacketed, aluminum interlocking armor. Jacketed aluminum interlocking armor provides the best balance of ruggedness, flexibility and low weight.

Indoor/Outdoor Armored Distribution cables provide added protection for campus network cabling between buildings where short installation runs allow for cost savings made by utilizing tight buffered cables. Flame rated cables, both OFCP (Plenum) and OFCR (Riser) rated jackets allow these products to be deployed indoors within the premise and retain compliance to applicable flame safety standards.

For outdoor applications, the cables utilize both UV-stabilized jacketing materials with anti-fungal additives; core cables also contain water-blocking elements to prevent water migration. Products are approved for use in mining applications.

Features

- Available with 2 to 72 fibers
- Low weight jacketed, interlocking armor
- OFCP (Plenum) and OFCR (Riser) rated jackets
- Moisture-resistant, fungus-resistant and UV-resistant outer jacket

Applications

- Building Interconnections (Campus LAN)
- Inside plant and outside plant environments
- Mining applications

Cable Components

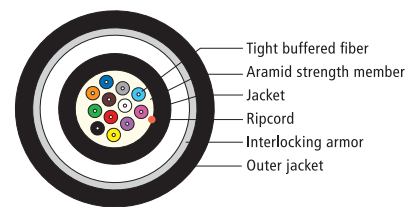
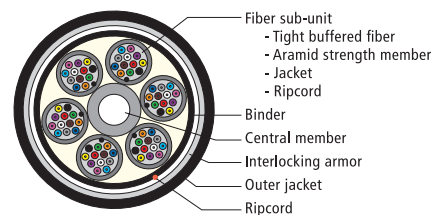

Fiber Specifications

CORE SIZE/ FIBER TYPE	ISO/ IEC	MAXIMUM ATTENUATION (dB/km)			OVERFILL LAUNCH MIN. BANDWIDTH (MHz•km)		EMBC (MHz•km)	GIGABIT ETHERNET MAX. LINK DISTANCE (meters)		10 GIGABIT ETHERNET MAX. LINK DISTANCE (meters)	
		850 nm	1300 nm	1550 nm	850 nm	1300 nm		850 nm	1300 nm	850 nm	1300 nm
(6) 62.5 Giga-Link™ 300	OM1	3.5	1.2	N/A	200	600	N/A	300	550	32	—
(5) 50 Giga-Link™ 600	OM2	3.5	1.5	N/A	500	500	N/A	600	600	82	—
(L) 50 Laser-Link 300	OM3	3.0	1.2	N/A	1,500	500	2,000	1000	550	300	—
(C) 50 Laser-Link 550	OM4	3.0	1.2	N/A	3,500	500	4,700	1040	550	550	—
(W) AFL Wideband Multimode	OM5	N/A	1.2	N/A	3,500	500	4,700	1040	550	550	—
(9) Single-mode (ITU G.652.D/G.657.A1)	OS2	N/A	0.5	0.5	N/A	N/A	N/A	N/A	5,000	N/A	10,000



STOCK ITEM

continued →

Indoor/Outdoor Armored Tight Buffered Circular Premise Cable

Mechanical Data

AFL NO.		FIBER COUNT	NOMINAL DIAMETER inches (mm)				WEIGHT lbs		TENSION lbs (N)				BENDING RADIUS Inches (cm)	
RISER	PLENUM		RISER	PLENUM	RISER	PLENUM	RISER		PLENUM		INSTALL	LONGTERM	INSTALL	LONGTERM
							INSTALL	LONGTERM	INSTALL	LONGTERM				
KR002★481801-AIAR	KQ002★461801-AIAP	2	0.52 (13.30)	0.52 (13.30)	126	144	150 (660)	45 (198)	300 (1335)	90 (396)	7.8 (199.50)	5.2 (132.00)		
KR004★481801-AIAR	KQ004★501801-AIAP	4	0.52 (13.30)	0.52 (13.30)	128	147	150 (660)	45 (198)	300 (1335)	90 (396)	7.8 (199.50)	5.2 (132.00)		
KR006★531801-AIAR	KQ006★541801-AIAP	6	0.52 (13.30)	0.52 (13.30)	133	169	150 (660)	45 (198)	300 (1335)	90 (396)	7.8 (199.50)	5.2 (132.00)		
KR008★561801-AIAR	KQ008★581801-AIAP	8	0.56 (14.30)	0.56 (14.30)	150	192	150 (660)	45 (198)	300 (1335)	90 (396)	8.4 (214.50)	5.6 (142.00)		
KR012★651801-AIAR	KQ012★611801-AIAP	12	0.56 (14.30)	0.56 (14.30)	155	198	150 (660)	45 (198)	300 (1335)	90 (396)	8.4 (214.50)	5.6 (142.00)		
KR018★801801-AIAR	KQ018★751801-AIAP	18	0.63 (15.90)	0.63 (15.90)	191	204	300 (1335)	90 (396)	300 (1335)	90 (396)	9.5 (238.50)	6.3 (160.00)		
KR024★871801-AIAR	KQ024★791801-AIAP	24	0.68 (17.30)	0.63 (15.90)	214	223	300 (1335)	90 (396)	300 (1335)	90 (396)	10.2 (259.50)	6.8 (172.00)		
KR024★611881-AIAR	—	24	1.02 (25.90)	—	320	—	300 (1335)	90 (396)	—	—	15.3 (388.50)	10.2 (259.50)		
KR036★611881-AIAR	KQ036★591881-AIAP	36	1.02 (25.90)	0.96 (24.30)	320	320	300 (1335)	90 (396)	300 (1335)	90 (396)	15.3 (388.50)	10.2 (259.50)		
KR048★611881-AIAR	KQ048★591881-AIAP	48	1.02 (25.90)	1.02 (25.90)	320	360	300 (1335)	90 (396)	300 (1335)	90 (396)	15.3 (388.50)	10.2 (259.50)		
KR060★611881-AIAR	KQ060★591881-AIAP	60	1.12 (28.40)	1.12 (28.40)	430	430	300 (1335)	90 (396)	300 (1335)	90 (396)	16.8 (426.00)	11.2 (284.50)		
KR072★611881-AIAR	KQ072★591881-AIAP	72	1.17 (29.70)	1.22 (30.96)	430	500	300 (1335)	90 (396)	300 (1335)	90 (396)	17.6 (445.50)	11.7 (297.00)		

★ Fiber Types – Replace asterisk (★) in AFL number with number in the Fiber Specifications table on previous page.

Qualifications

Governing Body	Standard Code	Component
Telcordia	GR-20-CORE GR-409-CORE	Water-Blocked Cabled Buffer Tube Core Weatherized Cable
EIA/TIA	568, 568-A	Sub-units
ICEA	S-104-696	Sub-units
RoHS	2002/95/EC	Cable
MSHA		

Temperature Specifications

	Temperature Range	
	Plenum	Riser
Installation	-10°C to +70°C	-20°C to +75°C
Operating	-40°C to +70°C	-40°C to +75°C
Storage	-40°C to +70°C	-40°C to +75°C

Contact AFL for further details.

Premise Cable

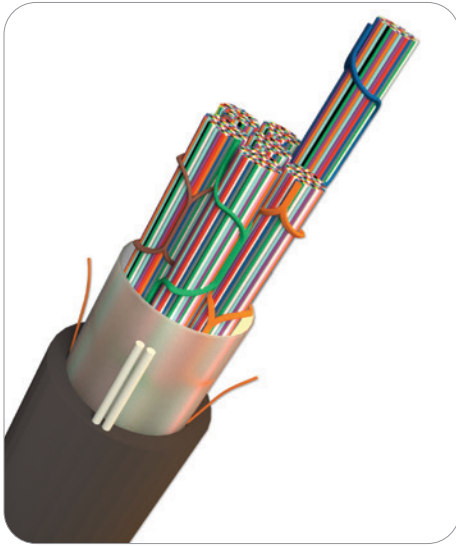

Wrapping Tube Cable (WTC) with SpiderWeb Ribbon® (SWR®) – 250 μm Fiber/250 μm Pitch

The 250 μm Fiber/250 μm Pitch Wrapping Tube Cable (WTC), with SpiderWeb Ribbon® (SWR®), is an ultra-high density outside plant cable designed specifically for fiber-to-the-home (FTTH) or access markets. It is compliant with the latest issue of the outside plant cable standard, Telcordia GR-20. With an ultra-high density and a new ribbon technology called SpiderWeb Ribbon®, WTC provides the smallest cable diameter and lowest weight, high-fiber count ribbon cable in the industry. WTC with SWR® cables are available in fiber counts from 144 to 1,728.

SWR® is a bonded fiber ribbon design allowing for either a highly efficient ribbon splicing or an individual fiber breakout splicing process. This flexibility allows for a single cable design to cover a diverse set of applications from access networks to high-fiber count mass fusion splicing. With the ability to roll and conform, the SWR® provides for ultra-high density packaging in the WTC.

Features

- Collapsible ribbon reduces size of cable compared to other encapsulated or pliable ribbon technologies
- Design optimizes the fiber packing density making WTC-SWR cables the smallest ribbon cables without compromising robustness of the cable
- Small-diameter cable allows more optical fibers to be placed into crowded or limited-space pathways
- Water-blocked core
- Light weight for easy handling in the field compared to traditional cables
- Completely Gel-free for reduced time to access fiber and prep for splicing

Applications

- Data Center Inter-building Connections
- Access Provider Metro Rings
- Service Provider FTTx
- Cable TV Subscriber Networks
- Metro Rail Track-side Network Links
- Suitable for Aerial Lashing, Pulled-in-duct, Air-Jetted-in-Duct
- Campus LAN

SWR Technology



12F SWR®

Contrahelical dual binder system

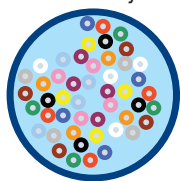

Multiple 12F SWR® Bundle

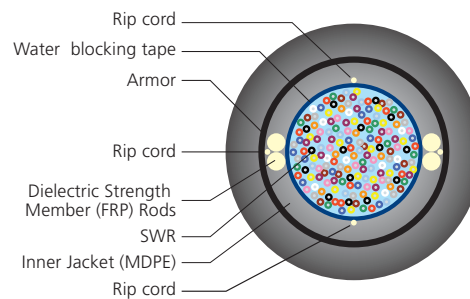

Armored
4-rod FRP
(288F - 1,728F)

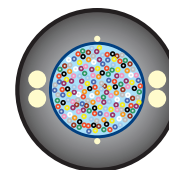

Non-armored
4-rod FRP
(288F - 1,728F)

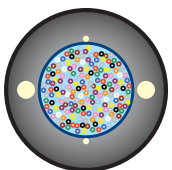
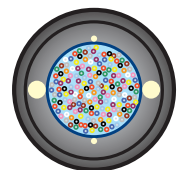

Non-armored &
Armored
2-rod FRP
(144F)

continued
→

Wrapping Tube Cable (WTC) with SpiderWeb Ribbon® (SWR®) – 250 μm Fiber/ 250 μm Pitch

Mechanical Data—Non-Armored

DESCRIPTION	FIBER COUNT	BINDER UNIT	NOMINAL DIAMETER	WEIGHT	SHORT TERM / INSTALLATION		LONG TERM / STORAGE / STATIC	
			inches (mm)	lbs / 1,000 ft (kg/km)	MAX TENSILE LOAD lbs (N)	MIN BEND RADIUS inches (mm)	MAX TENSILE LOAD lbs (N)	MIN BEND RADIUS inches (mm)
ACE FIBER								
LWSE-144-9-C-144-1-00N1D-*	144	1 X 144F	0.43 (11.0)	61 (90)	607 (2700)	8.7 (221)	182 (810)	6.5 (165)
LWSE-288-9-C-288-1-00N1D-*	288	1 X 288F	0.47 (12.0)	71 (105)	607 (2700)	9.5 (242)	182 (810)	7.1 (181)
LWSE-432-9-C-72-6-00N1D-*	432	6 X 72F	0.53 (13.5)	91 (135)	607 (2700)	10.6 (270)	182 (810)	8.0 (203)
LWSE-576-9-C-72-8-00N1D-*	576	8 X 72F	0.59 (15.0)	111 (165)	607 (2700)	11.8 (300)	182 (810)	8.9 (226)
LWSE-864-9-C-72-12-00N1D-*	864	12 X 72F	0.69 (17.5)	145 (215)	607 (2700)	13.8 (351)	182 (810)	10.3 (262)
SR15E FIBER								
LWSE-144-K-C-144-1-00N1D-*	144	1 X 144F	0.43 (11.0)	61 (90)	607 (2700)	8.7 (221)	182 (810)	6.5 (165)
LWSE-288-K-C-288-1-00N1D-*	288	1 X 288F	0.47 (12.0)	71 (105)	607 (2700)	9.5 (242)	182 (810)	7.1 (181)
LWSE-432-K-C-72-6-00N1D-*	432	6 X 72F	0.53 (13.5)	91 (135)	607 (2700)	10.6 (270)	182 (810)	8.0 (203)
LWSE-576-K-C-72-8-00N1D-*	576	8 X 72F	0.59 (15.0)	111 (165)	607 (2700)	11.8 (300)	182 (810)	8.9 (226)
LWSE-864-K-C-72-12-00N1D-*	864	12 X 72F	0.69 (17.5)	145 (215)	607 (2700)	13.8 (351)	182 (810)	10.3 (262)
LWSE-1152-K-C-144-8-00N1D-*	1152	8 X 144F	0.73 (18.5)	161 (240)	607 (2700)	14.6 (371)	182 (810)	10.9 (277)
LWSE-1728-K-C-144-12-00N1D-*	1728	12 X 144F	0.91 (23.0)	242 (360)	607 (2700)	18.1 (460)	182 (810)	13.6 (346)

* NOTE: To designate length markings in AFL No., replace asterisk * with (FT) for Feet or (M) for Meters.

Mechanical Data—Armored

DESCRIPTION	FIBER COUNT	BINDER UNIT	NOMINAL DIAMETER	WEIGHT	SHORT TERM / INSTALLATION		LONG TERM / STORAGE / STATIC	
			inches (mm)	lbs / 1,000 ft (kg/km)	MAX TENSILE LOAD lbs (N)	MIN BEND RADIUS inches (mm)	MAX TENSILE LOAD lbs (N)	MIN BEND RADIUS inches (mm)
LWSE-144-9-C-144-1-10S1D-*	144	1 X 144F	0.63 (16.0)	148 (220)	607 (2700)	12.6 (320)	182 (810)	9.5 (242)
LWSE-288-9-C-288-1-10S1D-*	288	1 X 288F	0.69 (17.5)	172 (255)	607 (2700)	13.8 (351)	182 (810)	10.3 (262)
LWSE-432-9-C-72-6-10S1D-*	432	6 X 72F	0.75 (19.0)	202 (300)	607 (2700)	15.0 (381)	182 (810)	11.2 (285)
LWSE-576-9-C-72-8-10S1D-*	576	8 X 72F	0.81 (20.5)	235 (350)	607 (2700)	16.1 (409)	182 (810)	12.1 (307)
LWSE-864-9-C-72-12-10S1D-*	864	12 X 72F	0.91 (23.0)	286 (425)	607 (2700)	18.1 (460)	182 (810)	13.6 (346)
LWSE-1728-K-C-144-12-10S1D-*	1728**	12 X 144F	1.14 (29.0)	410 (610)	607 (2700)	22.8 (579)	182 (810)	17.1 (435)

NOTES:

* To designate length markings in AFL No., replace asterisk * with (FT) for Feet or (M) for Meters.

** Modified temperature performance

Optical Fiber

FIBER COUNT	FIBER DIAMETER	FIBER PITCH	FIBER DESIGNATOR	MFD	MAXIMUM ATTENUATION (CABLED) dB/km		
					1310 nm	1383 nm	1550 nm
Fujikura ACE (144F to 864F)	250 μm	250 μm	9 (ITU-T G.652.D and G.657.A1)	9.2 ± 0.4 μm	≤ 0.40	≤ 0.40	≤ 0.30
Fujikura SR15E (144F to 1728F)	250 μm	250 μm	K (ITU-T G.652.D and G.657.A1)	8.6 ± 0.4 μm	≤ 0.40	≤ 0.40	≤ 0.30

continued

Wrapping Tube Cable (WTC) with SpiderWeb Ribbon® (SWR®) – 250 µm Fiber/ 250 µm Pitch

Stripe Ring Fiber Identification

R NO.	STRIPE RING MARKING	R NO.	STRIPE RING MARKING	R NO.	STRIPE RING MARKING	R NO.	STRIPE RING MARKING
1	█	7	███	13	██████	19	██████████
2	██	8	████	14	███████	20	████████
3	███	9	█████	15	██████	21	█████████
4	████	10	█████	16	███████	22	█████████
5	█████	11	██████	17	████████	23	██████████
6	██████	12	███████	18	█████████	24	██████████

FIBER COUNT	BINDER UNIT (BU)		RING MARKINGS
144F	No Binder Unit		1-12 Ring Marking
288F	No Binder Unit		1-24 Ring Marking
432F	6 Binder Units	1 2 3 4 5 6	
576F	8 Binder Units	1 2 3 4 5 6 7 8	1-6 Ring Marking
864F	12 Binder Units	1 2 3 4 5 6 7 8 9 10 11 12	
1152F	8 Binder Units	1 2 3 4 5 6 7 8	1-12 Ring Marking
1728F	12 Binder Units	1 2 3 4 5 6 7 8 9 10 11 12	1-12 Ring Marking

Temperature Specifications

TEMPERATURE RANGE	
OPERATION	-40°F to +158°F (-40°C to +70°C)
STORAGE	-40°F to +158°F (-40°C to +70°C)
INSTALLATION	-22°F to +140°F (-30°C to +60°C)

Qualifications

GOVERNING BODY	STANDARD CODE	COMPONENT
Telcordia	GR-20	Fiber Optic Cable

Contact AFL for further details.

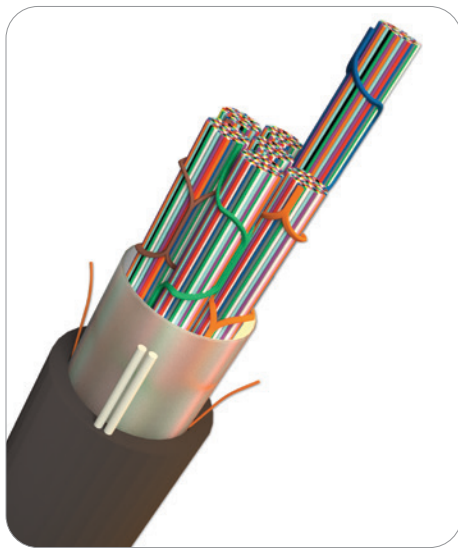

Wrapping Tube Cable (WTC) with SpiderWeb Ribbon® (SWR®) – 200 μm Fiber/250 μm Pitch

The 200 μm fiber/250 μm pitch Wrapping Tube Cable (WTC), with SpiderWeb Ribbon® (SWR®), is an ultra-high density outside plant cable designed specifically for fiber-to-the-home (FTTH) or access markets. It is compliant with the latest issue of the outside plant cable standard, Telcordia GR-20. With an ultra-high density and a new ribbon technology called SpiderWeb Ribbon®, WTC provides the smallest cable diameter and lowest weight, high-fiber count ribbon cable in the industry. WTC with SWR® cables are available in fiber counts of 864, 1,728, 3,456 and 6,912.

SWR® is a bonded fiber ribbon design allowing for either a highly efficient ribbon splicing or an individual fiber breakout splicing process. This flexibility allows for a single cable design to cover a diverse set of applications from access networks to high-fiber count mass fusion splicing. With the ability to roll and conform, the SWR® provides for ultra-high density packaging in the WTC.

Features

- Collapsible ribbon reduces size of cable compared to other encapsulated or pliable ribbon technologies
- Design optimizes the fiber packing density making WTC-SWR cables the smallest ribbon cables without compromising robustness of the cable
- Small-diameter cable allows more optical fibers to be placed into crowded or limited-space pathways
- Water-blocked core
- Light weight for easy handling in the field compared to traditional cables
- Completely Gel-free for reduced time to access fiber and prep for splicing

Applications

- Data Center Inter-building Connections
- Access Provider Metro Rings
- Service Provider FTTx
- Cable TV Subscriber Networks
- Metro Rail Track-side Network Links
- Suitable for Aerial Lashing, Pulled-in-duct, Air-Jetted-in-Duct
- Campus LAN

SWR Technology

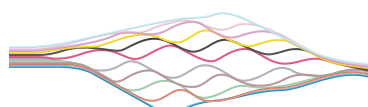

12F SWR

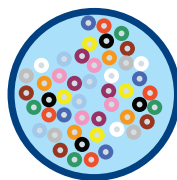

Multiple 12F SWR Bundle

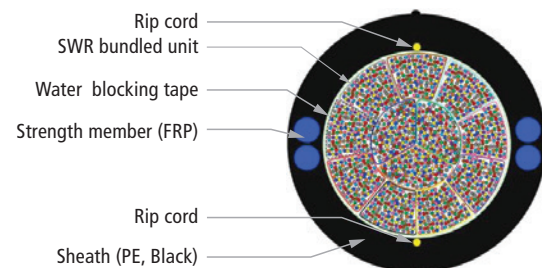

Non-armored
(864F, 1728F, 3456F
and 6912F)

continued
→

Wrapping Tube Cable (WTC) with SWR® – 200 µm Fiber/250 µm Pitch

Mechanical Data—Non-Armored

DESCRIPTION	FIBER COUNT	BINDER UNIT	NOMINAL DIAMETER	WEIGHT lbs/1,000 ft (kg/km)	SHORT TERM/INSTALLATION		LONG TERM/STORAGE/STATIC	
			inches (mm)		MAX TENSILE LOAD lbs (N)	MIN BEND RADIUS inches (mm)	MAX TENSILE LOAD lbs (N)	MIN BEND RADIUS inches (mm)
LWSE-864-BE-C-72-12-00N1D-*	864	12 X 72F	0.63 (16.0)	124 (185)	607 (2700)	12.6 (320)	182 (810)	9.5 (241)
LWSE-1728-BE-C-144-12-00N1D-*	1728	12 X 144F	0.85 (21.5)	202 (300)	607 (2700)	16.9 (430)	182 (810)	12.7 (323)
LWSE-3456-BE-C-144-24-00N1D-*	3456	24 X 144F	1.04 (26.5)	292 (435)	607 (2700)	20.9 (530)	182 (810)	15.7 (399)
LWSE-6912-BE-C-288-24-00N1D-*	6912	24 X 288F	1.38 (35.0)	514 (765)	607 (2700)	27.6 (700)	182 (810)	20.7 (525)

* NOTE: To designate length markings in AFL No., replace asterisk * with (FT) for Feet or (M) for Meters.

Optical Fiber

FIBER COUNT	FIBER DIA.	FIBER PITCH	FIBER DESIGNATOR	MFD	MAXIMUM ATTENUATION (CABLED) dB/km		
					1310 nm	1383 nm	1550 nm
Fujikura SR15E-200 (864, 1728, 3456, 6912)	200 µm	250 µm	BE (ITU-T G.652.D and G.657.A1)	8.6 ± 0.4 µm	≤ 0.35 dB/km	≤ 0.35 dB/km	≤ 0.25 dB/km

Stripe Ring Fiber Identification — 864, 1728, 3456

R NO.	STRIPE RING MARKING	R NO.	STRIPE RING MARKING	R NO.	STRIPE RING MARKING
1	█	5	██	9	████
2	██	6	███	10	████
3	███	7	████	11	█████
4	████	8	█████	12	██████

Stripe Ring Fiber Identification — 6,912

R NO.	STRIPE RING MARKING	R NO.	STRIPE RING MARKING	R NO.	STRIPE RING MARKING	R NO.	STRIPE RING MARKING
1	█	7	███	13	██████	19	██████████
2	██	8	████	14	██████	20	██████████
3	███	9	█████	15	██████	21	██████████
4	████	10	█████	16	██████	22	██████████
5	████	11	█████	17	██████	23	██████████
6	█████	12	██████	18	██████	24	██████████

FIBER COUNT	BINDER UNIT (BU)	RING MARKINGS
864F	12 Binder Units	1-6 Ring Marking
1728F	12 Binder Units	1-12 Ring Marking
3456F	24 Binder Units*	1-12 Ring Marking
6912F	24 Binder Units*	1-24 Ring Marking

*For binder units 13-24, the second binder unit is clear

Qualifications

GOVERNING BODY	STANDARD CODE	COMPONENT
Telcordia	GR-20	Fiber Optic Cable

Temperature Specifications

TEMPERATURE RANGE	
OPERATION	-40°F to +158°F (-40°C to +70°C)
STORAGE	-40°F to +158°F (-40°C to +70°C)
INSTALLATION	-22°F to +140°F (-30°C to +60°C)

Contact AFL for further details.

AFLglobal.com | 800.235.3423

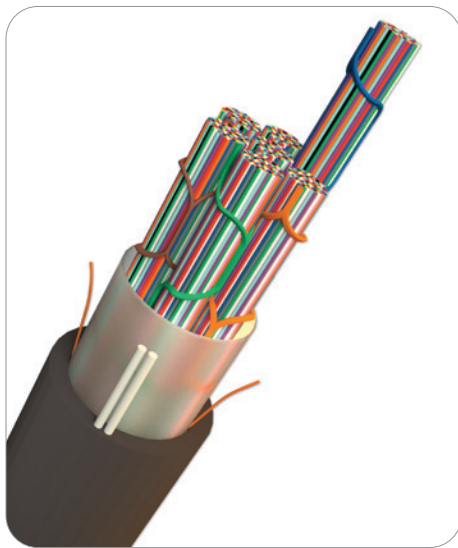

OSP Wrapping Tube Cable (WTC) with SpiderWeb Ribbon® (SWR®) – 200 μm Fiber/200 μm Pitch

The 200 μm fiber/200 μm pitch Wrapping Tube Cable (WTC) with SpiderWeb Ribbon® (SWR®) is an ultra-high density outside plant (OSP) cable designed specifically for fiber-to-the-home (FTTH) or access markets. It is compliant with the latest issue of the outside plant cable standard, Telcordia GR-20. With an ultra-high density and a new ribbon technology called SpiderWeb Ribbon®, WTC provides the smallest cable diameter and lowest weight, high-fiber count ribbon cable in the industry. WTC with SWR® cables are available in fiber counts of 864, 1,728, 3,456 and 6,912.

SWR® is a bonded fiber ribbon design allowing for either a highly efficient ribbon splicing or an individual fiber breakout splicing process. This flexibility allows for a single cable design to cover a diverse set of applications from access networks to high-fiber count mass fusion splicing. With the ability to roll and conform, the SWR® provides for ultra-high density packaging in the WTC.

Features

- Collapsible ribbon reduces size of cable compared to other encapsulated or pliable ribbon technologies
- Design optimizes the fiber packing density making WTC-SWR cables the smallest ribbon cables without compromising robustness of the cable
- Small-diameter cable allows more optical fibers to be placed into crowded or limited-space pathways
- Water-blocked core
- Light weight for easy handling in the field compared to traditional cables
- Completely Gel-free for reduced time to access fiber and prep for splicing

Applications

- Data Center Inter-building Connections
- Access Provider Metro Rings
- Service Provider FTTx
- Cable TV Subscriber Networks
- Metro Rail Track-side Network Links
- Suitable for Aerial Lashing, Pulled-in-duct, Air-Jetted-in-Duct
- Campus LAN

SWR Technology



12F SWR

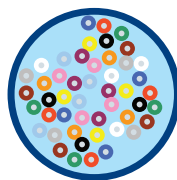

Multiple 12F SWR Bundle

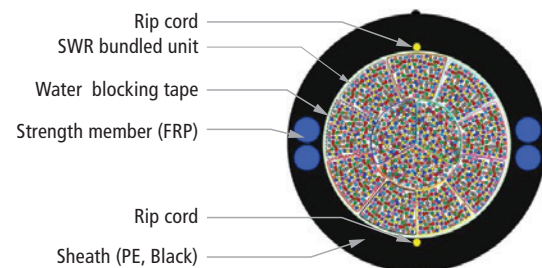

Non-armored
(864F, 1728F, 3456F
and 6912F)

continued
→

OSP Wrapping Tube Cable (WTC) with SWR® – 200 μm Fiber/200 μm Pitch

Mechanical Data—Non-Armored

DESCRIPTION	FIBER COUNT	BINDER UNIT	NOMINAL DIAMETER	WEIGHT lbs/1,000 ft (kg/km)	SHORT TERM/DYNAMIC/INSTALLATION		LONG TERM/STORAGE/STATIC	
			inches (mm)		MAX TENSILE LOAD lbs (N)	MIN BEND RADIUS inches (mm)	MAX TENSILE LOAD lbs (N)	MIN BEND RADIUS inches (mm)
LWSE-864-BD-C-72-12-00N1D-*	864	12 X 72F	0.59 (15.0)	114 (170)	607 (2700)	11.8 (300)	182 (810)	8.9 (225)
LWSE-1728-BD-C-144-12-00N1D-*	1728	12 X 144F	0.75 (19.0)	178 (265)	607 (2700)	15.0 (380)	182 (810)	11.2 (285)
LWSE-3456-BD-C-144-24-00N1D-*	3456	24 X 144F	1.00 (25.5)	302 (450)	607 (2700)	20.1 (510)	182 (810)	15.1 (383)
LWSE-6912-BD-C-288-24-00N1D-*	6912	24 X 288F	1.17 (29.8)	430 (640)	607 (2700)	23.5 (596)	182 (810)	17.6 (447)

* NOTE: To designate length markings in AFL No., replace asterisk * with (FT) for Feet or (M) for Meters.

Optical Fiber

FIBER TYPE	FIBER DIA.	FIBER PITCH	FIBER DESIGNATOR	MFD	MAXIMUM ATTENUATION (CABLED) dB/km		
					1310 nm	1383 nm	1550 nm
Fujikura SR15E-P200	200 μm	200 μm	BD (ITU-T G.652.D & G.657.A1)	8.6 ± 0.4 μm	≤ 0.40	≤ 0.40	≤ 0.30
Fujikura BIS-B-P200	200 μm	200 μm	BB (ITU-T G.652.D & G.657.A2)	8.6 ± 0.4 μm	≤ 0.40	≤ 0.40	≤ 0.30

Stripe Ring Fiber Identification — 864, 1728, 3456

R NO.	STRIPE RING MARKING	R NO.	STRIPE RING MARKING	R NO.	STRIPE RING MARKING	R NO.	STRIPE RING MARKING
1	█	4	███	7	████	10	█████
2	██	5	████	8	█████	11	██████
3	███	6	█████	9	██████	12	███████

Stripe Ring Fiber Identification — 6,912

R NO.	STRIPE RING MARKING	R NO.	STRIPE RING MARKING	R NO.	STRIPE RING MARKING	R NO.	STRIPE RING MARKING
1	█	7	████	13	██████	19	████████
2	██	8	█████	14	███████	20	█████████
3	███	9	██████	15	████████	21	█████████
4	████	10	███████	16	█████████	22	██████████
5	█████	11	████████	17	█████████	23	██████████
6	█████	12	████████	18	█████████	24	██████████

FIBER COUNT	BINDER UNIT (BU)	RING MARKINGS
864F	12 Binder Units	1-6 Ring Marking
1728F	12 Binder Units	1-12 Ring Marking
3456F	24 Binder Units*	1-12 Ring Marking
6912F	24 Binder Units*	1-24 Ring Marking

*For binder units 13-24, the second binder unit is clear

Qualifications

GOVERNING BODY	STANDARD CODE	COMPONENT
Telcordia	GR-20	Fiber Optic Cable

Contact AFL for further details.

AFLglobal.com | 800.235.3423

Temperature Specifications

TEMPERATURE RANGE	
OPERATION	-40°F to +158°F (-40°C to +70°C)
STORAGE	-40°F to +158°F (-40°C to +70°C)
INSTALLATION	-22°F to +140°F (-30°C to +60°C)

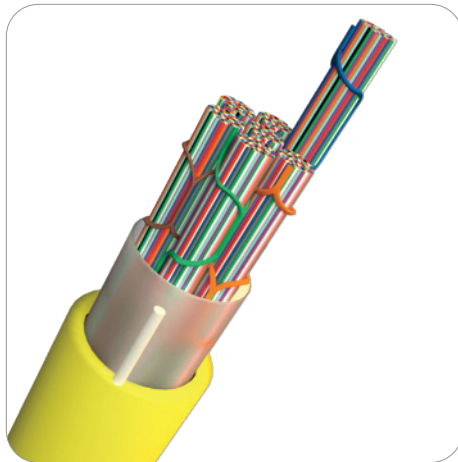

Flame-Retardant RI Indoor Wrapping Tube Cable (WTC) with SpiderWeb Ribbon® (SWR®) – 200 μm Fiber/250 μm Pitch

Flame-retardant (FR) RI Wrapping Tube Cable (WTC) with SpiderWeb Ribbon (SWR) is a high-density fiber optic ribbon cable intended for indoor network applications where riser-rated products are required. The FR RI-WTC-SWR incorporates the leading-edge SpiderWeb Ribbon technology in a robust, flame-retardant cable package that can be used within buildings.

SWR is a bonded fiber ribbon design allowing for either a highly efficient ribbon splicing or an individual fiber breakout splicing process. This flexibility allows a single cable design to cover diverse applications from access networks to high-fiber count mass fusion splicing. With the ability to roll and conform, the SWR provides ultra-high density packaging in cable form.

The FR RI-WTC-SWR product set is non-armored and meets Riser, CPR, and Low-Smoke, Zero-Halogen (LSZH) standards using Fujikura 200 μm SR15E-200 fiber (144F to 3456F) with 250 μm pitch constructions. The 250 μm ribbon pitch allows simple mass-fusion splicing with traditional 250 μm diameter ribbon fibers.

Ribbon Pitch Designs

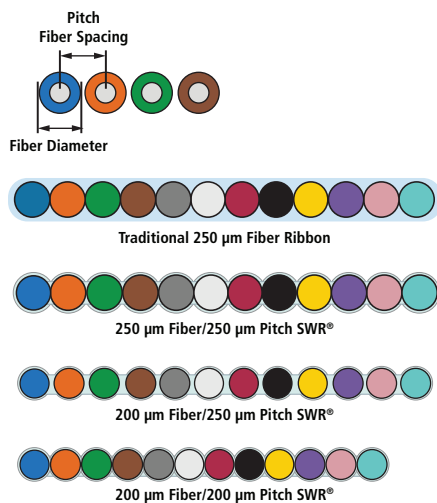

Features

- Collapsible ribbon reduces size of cable compared to other encapsulated or pliable ribbon technologies
- High-density 200 μm diameter fibers with 250 μm ribbon pitch separation for splice compatibility with 250 μm diameter fiber ribbon
- Design optimizes the fiber packing density making WTC/SWR cables the smallest ribbon cables without compromising the robustness of the cable
- Completely gel-free for reduced time to access fiber and prep for splicing

- Small-diameter cable allows more optical fibers to be placed into crowded or limited-space pathways
- Water-blocked core
- Lightweight for easy handling in the field compared to traditional cables
- Suitable for pulling and jetting installations

Applications

- Indoor installations
- Riser spaces within build structures

SWR Technology

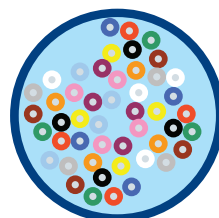
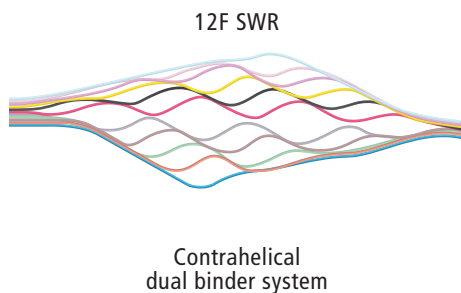

Multiple 12F SWR bundle
72F, 144F, OR 288 bundles
depending on cable fiber count

Cable Components

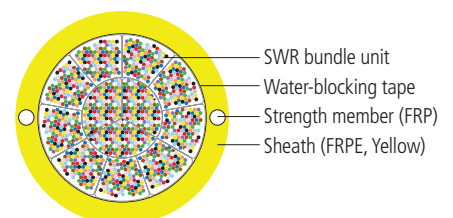

OFNR-LS
Non-armored
(144F to 3456F)

continued
→

Flame-Retardant RI Indoor WTC with SWR® – 200 μm Fiber/250 μm Pitch

Mechanical Data—Non-Armored

AFL NO.	EN 13501-6 CLASSIFICATION	FIBER COUNT	BINDER UNIT	NOMINAL DIAMETER	WEIGHT lbs/1,000 ft (kg/km)	SHORT TERM/DYNAMIC/ INSTALLATION		LONG TERM/STORAGE/ STATIC	
				inches (mm)		MAX TENSILE LOAD lbs (N)	MIN BEND RADIUS inches (mm)	MAX TENSILE LOAD lbs (N)	MIN BEND RADIUS inches (mm)
RI-OGNM12WTZTWBE SR15E-200 × 144 (*)	Cca-s1b,d1,a1	144	1 x 144F	0.49 (12.5)	111 (165)	300 (1330)	7.4 (188)	90 (399)	4.9 (125)
RI-OGNM12WTZTWBE SR15E-200 × 192 (*)	Cca-s1b,d1,a1	192	1 x 192F	0.51 (13.0)	118 (175)	300 (1330)	7.7 (195)	90 (399)	5.1 (130)
RI-OGNM12WTZTWBE SR15E-200 × 288 (*)	Cca-s1b,d1,a1	288	1 x 288F	0.51 (13.0)	128 (190)	300 (1330)	7.7 (195)	90 (399)	5.1 (130)
RI-OGNM12WTZTWBE SR15E-200 × 432 (*)	Cca-s1b,d1,a1	432	6 x 72F	0.57 (14.5)	144 (215)	300 (1330)	8.6 (218)	90 (399)	5.7 (145)
RI-OGNM12WTZTWBE SR15E-200 × 576 (*)	Cca-s1b,d1,a1	576	8 x 72F	0.61 (15.5)	161 (240)	300 (1330)	9.2 (233)	90 (399)	6.1 (155)
RI-OGNM12WTZTWBE SR15E-200 × 864 (*)	Cca-s1b,d1,a1	864	12 x 72F	0.67 (17.0)	195 (290)	607 (2700)	10.0 (255)	180 (810)	6.7 (170)
RI-OGNM12WTZTWBE SR15E-200 × 1152 (*)	Cca-s1b,d1,a1	1152	8 x 144F	0.71 (18.0)	218 (325)	607 (2700)	10.6 (270)	180 (810)	7.1 (180)
RI-OGNM12WTZTWBE SR15E-200 × 1728 (*)	Cca-s1b,d1,a1	1728	12 x 144F	0.85 (21.5)	319 (475)	607 (2700)	12.7 (323)	180 (810)	8.5 (215)
RI-OGNM12WTZTWBE SR15E-200 × 2880 (*)	Cca-s1,d0,a1	2880	10 x 288F	0.98 (25.0)	413 (615)	607 (2700)	14.8 (375)	180 (810)	9.8 (250)
RI-OGNM12WTZTWBE SR15E-200 × 3456 (*)	Cca-s1,d0,a1	3456	24 x 144F	1.00 (25.5)	453 (675)	607 (2700)	15.1 (383)	180 (810)	10.0 (255)

* NOTE: To designate length markings in AFL No., replace asterisk * with (FT) for Feet or (M) for Meters.

Optical Fiber

OPTICAL FIBER TYPE	FIBER DIAMETER	FIBER RIBBON PITCH	OPTICAL FIBER STANDARD	MODE FIELD DIAMETER AT 1310 nm	MAXIMUM ATTENUATION (CABLED) dB/km	
					1383 nm	1550 nm
Fujikura SR15E-200	200 μm	250 μm	ITU-T G.652.D/G.657.A1	8.6 ± 0.4 μm	≤ 0.40	≤ 0.30

Stripe Ring Fiber Identification

R NO.	STRIPE RING MARKING	R NO.	STRIPE RING MARKING	R NO.	STRIPE RING MARKING	R NO.	STRIPE RING MARKING
1	█	7	███	13	██████	19	██████████
2	██	8	████	14	████████	20	██████████
3	███	9	█████	15	██████	21	██████████
4	████	10	█████	16	██████	22	██████████
5	█████	11	█████	17	██████	23	██████████
6	█████	12	█████	18	██████	24	██████████

FIBER COUNT	BINDER UNIT	BINDER UNITS (BU)												RING MARKINGS	
144	1 x 144F	No Binder Unit												1-12 Ring Marking	
192	1 x 192F	No Binder Unit												1-16 Ring Marking	
288	1 x 288F	No Binder Unit												1-24 Ring Marking	
432	6 x 72F	6 Binder Units	1	2	3	4	5	6							1-6 Ring Marking
576	8 x 72F	8 Binder Units	1	2	3	4	5	6	7	8					
864	12 x 72F	12 Binder Units	1	2	3	4	5	6	7	8	9	10	11	12	1-12 Ring Marking
1152	8 x 144F	8 Binder Units	1	2	3	4	5	6	7	8					
1728	12 x 144F	12 Binder Units	1	2	3	4	5	6	7	8	9	10	11	12	1-24 Ring Marking
2880	10 x 288F	10 Binder Units	1	2	3	4	5	6	7	8	9	10			
3456	24 x 144F	24 Binder Units*	1	2	3	4	5	6	7	8	9	10	11	12	1 - 12 Ring Marking
			13	14	15	16	17	18	19	20	21	22	23	24	

*For binder units 13-24, the second binder unit is clear

continued
→

Flame-Retardant RI Indoor WTC with SWR® – 200 μm Fiber/250 μm Pitch

Temperature Specifications

TEMPERATURE RANGE	
INSTALLATION	-14°F to +140°F (-10°C to +60°C)
OPERATING	-40°F to +158°F (-40°C to +70°C)
STORAGE	-40°F to +158°F (-40°C to +70°C)

Qualifications

GOVERNING BODY	STANDARD CODE
UL	1666 (OFNR) 1685 (OFNG-LS)
ANSI/ICEA	S-83-596
IEC	60794-1-22
EU	EN 13501-6 (CPR)

Contact AFL for further details.

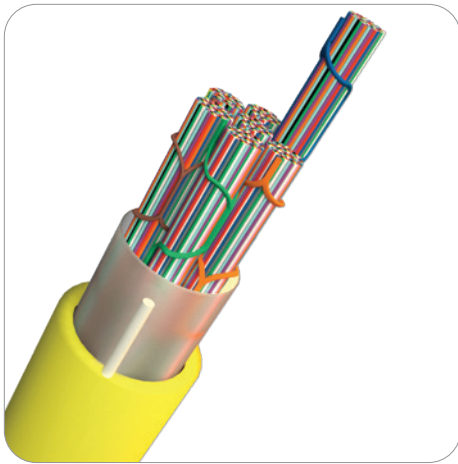

Flame-Retardant RI Indoor Wrapping Tube Cable (WTC) with SpiderWeb Ribbon® (SWR®) – 200 µm Fiber/200 µm Pitch

Flame-retardant (FR) RI Wrapping Tube Cable (WTC) with SpiderWeb Ribbon (SWR) is a high-density fiber optic ribbon cable intended for indoor network applications where riser-rated products are required. The FR RI-WTC-SWR incorporates the leading-edge SpiderWeb Ribbon technology in a robust, flame-retardant cable package that can be used within buildings.

SWR is a bonded fiber ribbon design allowing for either a highly efficient ribbon splicing or an individual fiber breakout splicing process. This flexibility allows a single cable design to cover diverse applications from access networks to high-fiber count mass fusion splicing. With the ability to roll and conform, the SWR provides ultra-high density packaging in cable form.

The FR RI-WTC-SWR product set is non-armored and meets Riser, CPR, and Low-Smoke, Zero-Halogen (LSZH) standards using Fujikura 200 µm SR15E-P200 fiber (144F to 3456F) with 200 µm pitch constructions.

Ribbon Pitch Designs

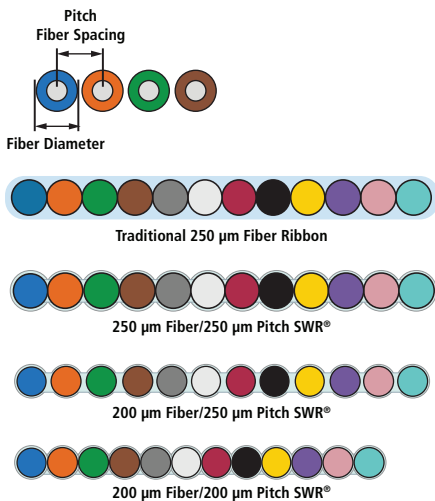

Features

- Collapsible ribbon reduces size of cable compared to other encapsulated or pliable ribbon technologies
- Design optimizes the fiber packing density making WTC/SWR cables the smallest ribbon cables without compromising the robustness of the cable
- Completely gel-free for reduced time to access fiber and prep for splicing
- Small-diameter cable allows more optical fibers to be placed into crowded or limited-space pathways

- Water-blocked core
- Lightweight for easy handling in the field compared to traditional cables
- Suitable for pulling and jetting installations

Applications

- Indoor installations
- Riser spaces within build structures

SWR Technology

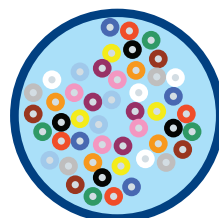
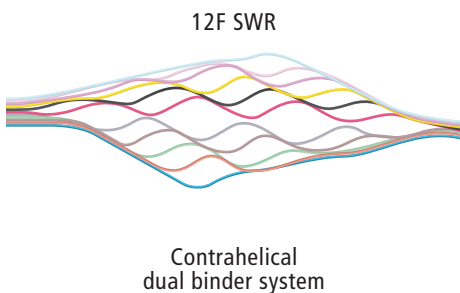

72F, 144F, OR 288 bundles depending on cable fiber count

Cable Components

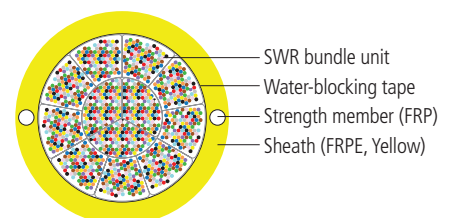

OFNR-LS Non-armored (144F to 3456F)

Flame-Retardant RI Indoor WTC with SWR® – 200 μm Fiber/200 μm Pitch

Mechanical Data—Non-Armored

AFL NO.	EN 13501-6 CLASSIFICATION	FIBER COUNT	BINDER UNIT	NOMINAL DIAMETER	WEIGHT lbs/1,000 ft (kg/km)	SHORT TERM/DYNAMIC/ INSTALLATION		LONG TERM/STORAGE/ STATIC	
				inches (mm)		MAX TENSILE LOAD lbs (N)	MIN BEND RADIUS inches (mm)	MAX TENSILE LOAD lbs (N)	MIN BEND RADIUS inches (mm)
RI-OGNM12WTZTWBE SR15E-P200 × 144 (*)	Cca-s1b,d1,a1	144	1 x 144F	0.49 (12.5)	111 (165)	300 (1330)	7.4 (188)	90 (399)	4.9 (125)
RI-OGNM12WTZTWBE SR15E-P200 × 192 (*)	Cca-s1b,d1,a1	192	1 x 192F	0.51 (13.0)	124 (185)	300 (1330)	7.7 (195)	90 (399)	5.1 (130)
RI-OGNM12WTZTWBE SR15E-P200 × 288 (*)	Cca-s1b,d1,a1	288	1 x 288F	0.51 (13.0)	124 (185)	300 (1330)	7.7 (195)	90 (399)	5.1 (130)
RI-OGNM12WTZTWBE SR15E-P200 × 432 (*)	Cca-s1b,d1,a1	432	6 x 72F	0.55 (14.0)	141 (210)	300 (1330)	8.3 (210)	90 (399)	5.5 (140)
RI-OGNM12WTZTWBE SR15E-P200 × 576 (*)	Cca-s1b,d1,a1	576	8 x 72F	0.59 (15.0)	158 (235)	300 (1330)	8.9 (225)	90 (399)	5.9 (150)
RI-OGNM12WTZTWBE SR15E-P200 × 864 (*)	Cca-s1b,d1,a1	864	12 x 72F	0.65 (16.5)	188 (280)	607 (2700)	9.7 (248)	180 (810)	6.5 (165)
RI-OGNM12WTZTWBE SR15E-P200 × 1152 (*)	Cca-s1b,d1,a1	1152	8 x 144F	0.69 (17.5)	208 (310)	607 (2700)	10.3 (263)	180 (810)	6.9 (175)
RI-OGNM12WTZTWBE SR15E-P200 × 1728 (*)	Cca-s1b,d1,a1	1728	12 x 144F	0.83 (21.0)	306 (455)	607 (2700)	12.4 (315)	180 (810)	8.3 (210)
RI-OGNM12WTZTWBE SR15E-P200 × 3456 (*)	Cca-s1,d0,a1	3456	24 x 144F	1.00 (25.5)	453 (675)	607 (2700)	15.1 (383)	180 (810)	10.0 (255)

* NOTE: To designate length markings in AFL No., replace asterisk * with (FT) for Feet or (M) for Meters.

Optical Fiber

OPTICAL FIBER TYPE	FIBER DIAMETER	FIBER RIBBON PITCH	OPTICAL FIBER STANDARD	MODE FIELD DIAMETER AT 1310 nm	MAXIMUM ATTENUATION (CABLED) dB/km	
					1383 nm	1550 nm
Fujikura SR15E-P200	200 μm	200 μm	ITU-T G.652.D/G.657.A1	8.6 ± 0.4 μm	≤ 0.40	≤ 0.30

R NO.	STRIPE RING MARKING	R NO.	STRIPE RING MARKING	R NO.	STRIPE RING MARKING	R NO.	STRIPE RING MARKING
1	█	7	███	13	██████	19	██████████
2	██	8	████	14	████████	20	██████████
3	███	9	█████	15	██████	21	██████████
4	████	10	█████	16	██████	22	██████████
5	█████	11	█████	17	██████	23	██████████
6	█████	12	█████	18	██████	24	██████████

FIBER COUNT	FIBER BUNDLES	BINDER UNIT (BU)												RING MARKINGS													
144	1 x 144F	No Binder Unit												1 - 12 Ring Marking													
192	1 x 192F	No Binder Unit												1 - 16 Ring Marking													
288	1 x 288F	No Binder Unit												1 - 24 Ring Marking													
432	6 x 72F	6 Binder Units	1	2	3	4	5	6							1 - 6 Ring Marking												
576	8 x 72F	8 Binder Units	1	2	3	4	5	6	7	8						1 - 6 Ring Marking											
864	12 x 72F	12 Binder Units	1	2	3	4	5	6	7	8	9	10	11	12	1 - 6 Ring Marking												
1152	8 x 144F	8 Binder Units	1	2	3	4	5	6	7	8						1 - 12 Ring Marking											
1728	12 x 144F	12 Binder Units	1	2	3	4	5	6	7	8	9	10	11	12	1 - 12 Ring Marking												
3456	24 x 144F	24 Binder Units*	1	2	3	4	5	6	7	8	9	10	11	12	13	14	15	16	17	18	19	20	21	22	23	24	1 - 12 Ring Marking

*For binder units 13-24, the second binder unit is clear

continued
→



Flame-Retardant RI Indoor WTC with SWR® – 200 μm Fiber/200 μm Pitch

Temperature Specifications

TEMPERATURE RANGE	
INSTALLATION	-14°F to +140°F (-10°C to +60°C)
OPERATING	-40°F to +158°F (-40°C to +70°C)
STORAGE	-40°F to +158°F (-40°C to +70°C)

Qualifications

GOVERNING BODY	STANDARD CODE
UL	1666 (OFNR) 1685 (OFNG-LS)
ANSI/ICEA	S-83-596
IEC	60794-1-22
EU	EN 13501-6 (CPR)

Contact AFL for further details.

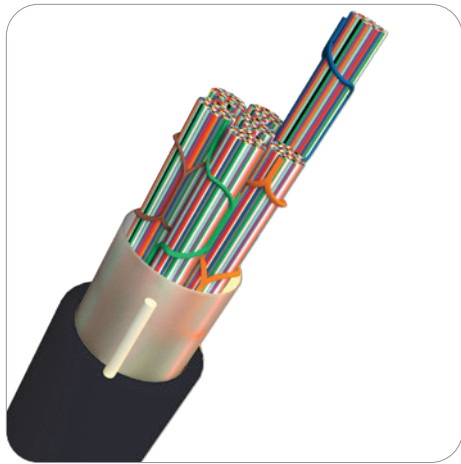

Flame-Retardant RIO Indoor/Outdoor Wrapping Tube Cable (WTC) with SpiderWeb Ribbon® (SWR®) – 200 μm Fiber/250 μm Pitch

Flame-retardant (FR) RIO Wrapping Tube Cable (WTC) with SpiderWeb Ribbon (SWR) is a high-density fiber optic ribbon cable intended for indoor/outdoor network applications where riser-rated products are required. The FR RIO-WTC-SWR incorporates the leading-edge SpiderWeb Ribbon technology in a robust, flame-retardant cable package that can be used within buildings. With the core water-blocking feature, it can also be routed outside provided the cable is housed within covered pathway spaces including duct-banks and cable trays.

SWR is a bonded fiber ribbon design allowing for either a highly efficient ribbon splicing or an individual fiber breakout splicing process. This flexibility allows a single cable design to cover diverse applications from access networks to high-fiber count mass fusion splicing. With the ability to roll and conform, the SWR provides ultra-high density packaging in cable form.

The FR RIO-WTC-SWR product set is non-armored and meets Riser, CPR, and Low-Smoke, Zero-Halogen (LSZH) standards using Fujikura 200 μm SR15E-200 fiber (144F to 3456F) with 250 μm pitch constructions. The 250 μm ribbon pitch allows simple mass-fusion splicing with traditional 250 μm diameter ribbon fibers.

Ribbon Pitch Designs

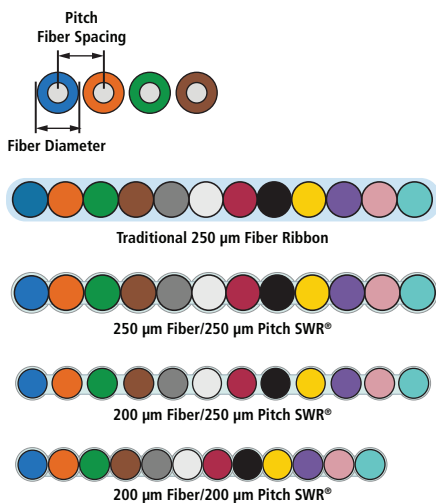

Features

- Collapsible ribbon reduces size of cable compared to other encapsulated or pliable ribbon technologies
- High-density 200 μm diameter fibers with 250 μm ribbon pitch separation for splice compatibility with 250 μm diameter fiber ribbon
- Design optimizes the fiber packing density making WTC/SWR cables the smallest ribbon cables without compromising the robustness of the cable
- Completely gel-free for reduced time to access fiber and prep for splicing

- Small-diameter cable allows more optical fibers to be placed into crowded or limited-space pathways
- Water-blocked core
- Lightweight for easy handling in the field compared to traditional cables
- Suitable for pulling and jetting installations

Applications

- Data Center Inter-building Connections
- Blowing or jetting in conduit

SWR Technology

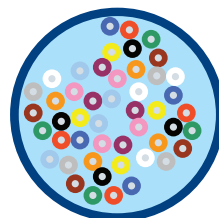
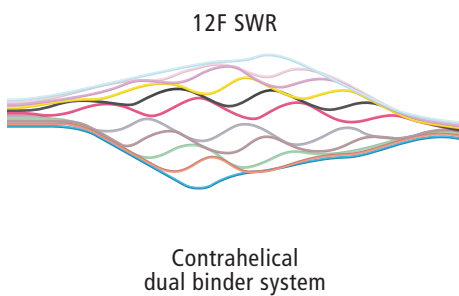

Multiple 12F SWR bundle
72F, 144F, OR 288 bundles
depending on cable fiber count

Cable Components

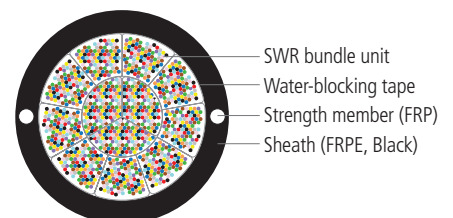

OFNR-LS
Non-armored
(144F to 3456F)

continued
→

Flame-Retardant RIO Indoor/Outdoor WTC with SWR® – 200 µm Fiber/250 µm Pitch

Mechanical Data—Non-Armored

AFL NO.	EN 13501-6 CLASSIFICATION	FIBER COUNT	BINDER UNIT	NOMINAL DIAMETER	WEIGHT lbs/1,000 ft (kg/km)	SHORT TERM/DYNAMIC/ INSTALLATION		LONG TERM/STORAGE/ STATIC	
				inches (mm)		MAX TENSILE LOAD lbs (N)	MIN BEND RADIUS inches (mm)	MAX TENSILE LOAD lbs (N)	MIN BEND RADIUS inches (mm)
RIO-OGNM12WTZTWBE SR15E-200 × 144 (*)	Cca-s1b,d1,a1	144	1 x 144F	0.49 (12.5)	111 (165)	300 (1330)	7.4 (188)	90 (399)	4.9 (125)
RIO-OGNM12WTZTWBE SR15E-200 × 192 (*)	Cca-s1b,d1,a1	192	1 x 192F	0.51 (13.0)	118 (175)	300 (1330)	7.7 (195)	90 (399)	5.1 (130)
RIO-OGNM12WTZTWBE SR15E-200 × 288 (*)	Cca-s1b,d1,a1	288	1 x 288F	0.51 (13.0)	128 (190)	300 (1330)	7.7 (195)	90 (399)	5.1 (130)
RIO-OGNM12WTZTWBE SR15E-200 × 432 (*)	Cca-s1b,d1,a1	432	6 x 72F	0.57 (14.5)	144 (215)	300 (1330)	8.6 (218)	90 (399)	5.7 (145)
RIO-OGNM12WTZTWBE SR15E-200 × 576 (*)	Cca-s1b,d1,a1	576	8 x 72F	0.61 (15.5)	161 (240)	300 (1330)	9.2 (233)	90 (399)	6.1 (155)
RIO-OGNM12WTZTWBE SR15E-200 × 864 (*)	Cca-s1b,d1,a1	864	12 x 72F	0.67 (17.0)	195 (290)	607 (2700)	10.0 (255)	180 (810)	6.7 (170)
RIO-OGNM12WTZTWBE SR15E-200 × 1152 (*)	Cca-s1b,d1,a1	1152	8 x 144F	0.71 (18.0)	218 (325)	607 (2700)	10.6 (270)	180 (810)	7.1 (180)
RIO-OGNM12WTZTWBE SR15E-200 × 1728 (*)	Cca-s1b,d1,a1	1728	12 x 144F	0.85 (21.5)	319 (475)	607 (2700)	12.7 (323)	180 (810)	8.5 (215)
RIO-OGNM12WTZTWBE SR15E-200 × 2880 (*)	Cca-s1,d0,a1	2880	10 x 288F	0.98 (25.0)	413 (615)	607 (2700)	14.8 (375)	180 (810)	9.8 (250)
RIO-OGNM12WTZTWBE SR15E-200 × 3456 (*)	Cca-s1,d0,a1	3456	24 x 144F	1.00 (25.5)	453 (675)	607 (2700)	15.1 (383)	180 (810)	10.0 (255)

* NOTE: To designate length markings in AFL No., replace asterisk * with (FT) for Feet or (M) for Meters.

Optical Fiber

OPTICAL FIBER TYPE	FIBER DIAMETER	FIBER RIBBON PITCH	OPTICAL FIBER STANDARD	MODE FIELD DIAMETER AT 1310 nm	MAXIMUM ATTENUATION (CABLED) dB/km	
					1383 nm	1550 nm
Fujikura SR15E-200	200 µm	250 µm	ITU-T G.652.D/G.657.A1	8.6 ± 0.4 µm	≤ 0.40	≤ 0.30

Stripe Ring Fiber Identification

R NO.	STRIPE RING MARKING	R NO.	STRIPE RING MARKING	R NO.	STRIPE RING MARKING	R NO.	STRIPE RING MARKING
1	█	7	███	13	██████	19	██████████
2	██	8	████	14	████████	20	██████████
3	███	9	█████	15	██████	21	██████████
4	████	10	█████	16	██████	22	██████████
5	█████	11	█████	17	██████	23	██████████
6	█████	12	█████	18	██████	24	██████████

FIBER COUNT	BINDER UNIT	BINDER UNITS (BU)												RING MARKINGS	
144	1 x 144F	No Binder Unit												1-12 Ring Marking	
192	1 x 192F	No Binder Unit												1-16 Ring Marking	
288	1 x 288F	No Binder Unit												1-24 Ring Marking	
432	6 x 72F	6 Binder Units	1	2	3	4	5	6							1-6 Ring Marking
576	8 x 72F	8 Binder Units	1	2	3	4	5	6	7	8					
864	12 x 72F	12 Binder Units	1	2	3	4	5	6	7	8	9	10	11	12	1-12 Ring Marking
1152	8 x 144F	8 Binder Units	1	2	3	4	5	6	7	8					
1728	12 x 144F	12 Binder Units	1	2	3	4	5	6	7	8	9	10	11	12	1-24 Ring Marking
2880	10 x 288F	10 Binder Units	1	2	3	4	5	6	7	8	9	10			
3456	24 x 144F	24 Binder Units*	1	2	3	4	5	6	7	8	9	10	11	12	1 - 12 Ring Marking
			13	14	15	16	17	18	19	20	21	22	23	24	

*For binder units 13-24, the second binder unit is clear

continued
→

Flame-Retardant RIO Indoor/Outdoor WTC with SWR® – 200 μm Fiber/250 μm Pitch

Temperature Specifications

TEMPERATURE RANGE	
INSTALLATION	-14°F to +140°F (-10°C to +60°C)
OPERATING	-40°F to +158°F (-40°C to +70°C)
STORAGE	-40°F to +158°F (-40°C to +70°C)

Qualifications

GOVERNING BODY	STANDARD CODE
UL	1666 (OFNR) 1685 (OFNG-LS)
ANSI/ICEA	S-83-596
IEC	60794-1-22
EU	EN 13501-6 (CPR)

Contact AFL for further details.

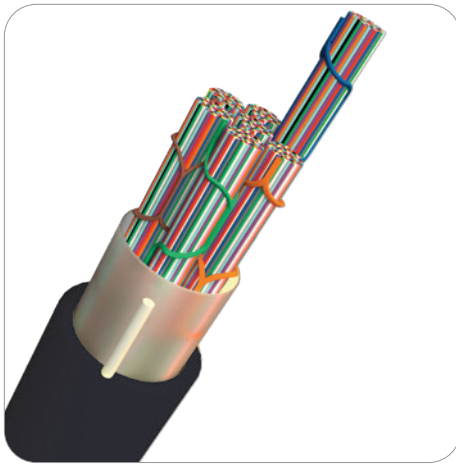

Flame-Retardant RIO Indoor/Outdoor Wrapping Tube Cable (WTC) with SpiderWeb Ribbon® (SWR®) – 200 μm Fiber/200 μm Pitch

Flame-retardant (FR) RIO Wrapping Tube Cable (WTC) with SpiderWeb Ribbon (SWR) is a high-density fiber optic ribbon cable intended for indoor/outdoor network applications where riser-rated products are required. The FR RIO-WTC-SWR incorporates the leading-edge SpiderWeb Ribbon technology in a robust, flame-retardant cable package that can be used within buildings. With the core water-blocking feature, it can also be routed outside provided the cable is housed within covered pathway spaces including duct-banks and cable trays.

SWR is a bonded fiber ribbon design allowing for either a highly efficient ribbon splicing or an individual fiber breakout splicing process. This flexibility allows a single cable design to cover diverse applications from access networks to high-fiber count mass fusion splicing. With the ability to roll and conform, the SWR provides ultra-high density packaging in cable form.

The FR RIO-WTC-SWR product set is non-armored and meets Riser, CPR, and Low-Smoke, Zero-Halogen (LSZH) standards using Fujikura 200 μm SR15E-P200 fiber (144F to 6912F) with 200 μm pitch constructions.

Ribbon Pitch Designs

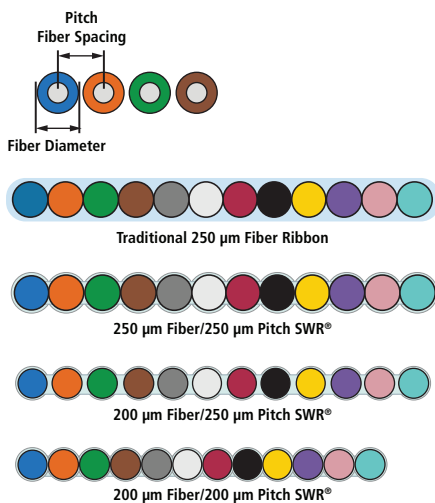

Features

- Collapsible ribbon reduces size of cable compared to other encapsulated or pliable ribbon technologies
- Design optimizes the fiber packing density making WTC/SWR cables the smallest ribbon cables without compromising the robustness of the cable
- Completely gel-free for reduced time to access fiber and prep for splicing
- Small-diameter cable allows more optical fibers to be placed into crowded or limited-space pathways

- Water-blocked core
- Lightweight for easy handling in the field compared to traditional cables
- Suitable for pulling and jetting installations

Applications

- Data Center Inter-building Connections
- Blowing or jetting in conduit

SWR Technology

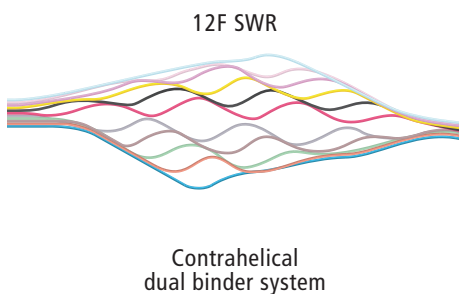

Contra-helical dual binder system

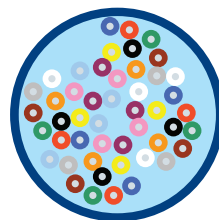

Multiple 12F SWR bundle
72F, 144F, OR 288 bundles
depending on cable fiber count

Cable Components

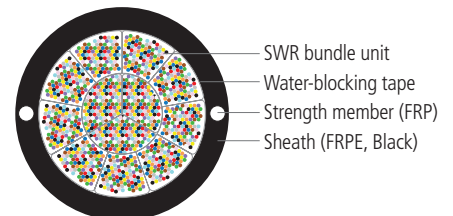

OFNR-LS
Non-armored
(144F to 6912F)

Flame-Retardant RIO Indoor/Outdoor WTC with SWR® – 200 µm Fiber/200 µm Pitch

Mechanical Data—Non-Armored

AFL NO.	EN 13501-6 CLASSIFICATION	FIBER COUNT	BINDER UNIT	NOMINAL DIAMETER	WEIGHT lbs/1,000 ft (kg/km)	SHORT TERM/DYNAMIC/ INSTALLATION		LONG TERM/STORAGE/ STATIC	
				inches (mm)		MAX TENSILE LOAD lbs (N)	MIN BEND RADIUS inches (mm)	MAX TENSILE LOAD lbs (N)	MIN BEND RADIUS inches (mm)
RIO-OGNM12WTZWBE SR15E-P200 × 144 (*)	Cca-s1b,d1,a1	144	1 x 144F	0.49 (12.5)	111 (165)	300 (1330)	7.4 (188)	90 (399)	4.9 (125)
RIO-OGNM12WTZWBE SR15E-P200 × 192 (*)	Cca-s1b,d1,a1	192	1 x 192F	0.51 (13.0)	124 (185)	300 (1330)	7.7 (195)	90 (399)	5.1 (130)
RIO-OGNM12WTZWBE SR15E-P200 × 288 (*)	Cca-s1b,d1,a1	288	1 x 288F	0.51 (13.0)	124 (185)	300 (1330)	7.7 (195)	90 (399)	5.1 (130)
RIO-OGNM12WTZWBE SR15E-P200 × 432 (*)	Cca-s1b,d1,a1	432	6 x 72F	0.55 (14.0)	141 (210)	300 (1330)	8.3 (210)	90 (399)	5.5 (140)
RIO-OGNM12WTZWBE SR15E-P200 × 576 (*)	Cca-s1b,d1,a1	576	8 x 72F	0.59 (15.0)	158 (235)	300 (1330)	8.9 (225)	90 (399)	5.9 (150)
RIO-OGNM12WTZWBE SR15E-P200 × 864 (*)	Cca-s1b,d1,a1	864	12 x 72F	0.65 (16.5)	188 (280)	607 (2700)	9.7 (248)	180 (810)	6.5 (165)
RIO-OGNM12WTZWBE SR15E-P200 × 1152 (*)	Cca-s1b,d1,a1	1152	8 x 144F	0.69 (17.5)	208 (310)	607 (2700)	10.3 (263)	180 (810)	6.9 (175)
RIO-OGNM12WTZWBE SR15E-P200 × 1728 (*)	Cca-s1b,d1,a1	1728	12 x 144F	0.83 (21.0)	306 (455)	607 (2700)	12.4 (315)	180 (810)	8.3 (210)
RIO-OGNM12WTZWBE SR15E-P200 × 3456 (*)	Cca-s1,d0,a1	3456	24 x 144F	1.00 (25.5)	453 (675)	607 (2700)	15.1 (383)	180 (810)	10.0 (255)
RIO-OGNM12WTZWBE BIS-B-P200 × 6912 (*)	Cca-s2,d0,a1	6912	24 x 288F	1.22 (31.0)	645 (960)	607 (2700)	18.3 (465)	180 (810)	12.2 (310)
RIO-OGNM12WTZWBE SR15E-P200 × 6912 (*)	Cca-s1,d0,a1	6912	24 x 288F	1.32 (33.5)	689 (1025)	607 (2700)	19.8 (503)	180 (810)	13.2 (335)

* NOTE: To designate length markings in AFL No., replace asterisk * with (FT) for Feet or (M) for Meters.

Optical Fiber

OPTICAL FIBER TYPE	FIBER DIAMETER	FIBER RIBBON PITCH	OPTICAL FIBER STANDARD	MODE FIELD DIAMETER AT 1310 nm	MAXIMUM ATTENUATION (CABLED) dB/km	
					1383 nm	1550 nm
Fujikura SR15E-P200	200 µm	200 µm	ITU-T G.652.D/G.657.A1	8.6 ± 0.4 µm	≤ 0.40	≤ 0.30

Stripe Ring Fiber Identification

R NO.	STRIPE RING MARKING	R NO.	STRIPE RING MARKING	R NO.	STRIPE RING MARKING	R NO.	STRIPE RING MARKING
1	█	7	███	13	██████	19	██████████
2	██	8	████	14	████████	20	██████████
3	███	9	█████	15	██████	21	██████████
4	████	10	█████	16	███████	22	██████████
5	█████	11	██████	17	████████	23	██████████
6	██████	12	███████	18	█████████	24	██████████

FIBER COUNT	BINDER UNIT (BU)	RING MARKINGS
288	4 Binder Units 1 2 3 4	1 - 6 Ring Marking
432	6 Binder Units 1 2 3 4 5 6	
576	8 Binder Units 1 2 3 4 5 6 7 8	
864	12 Binder Units 1 2 3 4 5 6 7 8 9 10 11 12	
1152	8 Binder Units 1 2 3 4 5 6 7 8	1 - 12 Ring Marking
1728	12 Binder Units 1 2 3 4 5 6 7 8 9 10 11 12	
2880	10 Binder Units 1 2 3 4 5 6 7 8 9 10	
3456	24 Binder Units* 1 2 3 4 5 6 7 8 9 10 11 12 13 14 15 16 17 18 19 20 21 22 23 24	
6912	24 Binder Units 1 2 3 4 5 6 7 8 9 10 11 12 13 14 15 16 17 18 19 20 21 22 23 24	1 - 24 Ring Marking

*For binder units 13-24, the second binder unit is clear

continued
→

Fiber Optic Cable



Flame-Retardant RIO Indoor/Outdoor WTC with SWR® – 200 µm Fiber/200 µm Pitch

Temperature Specifications

TEMPERATURE RANGE	
INSTALLATION	-14°F to +140°F (-10°C to +60°C)
OPERATING	-40°F to +158°F (-40°C to +70°C)
STORAGE	-40°F to +158°F (-40°C to +70°C)

Qualifications

GOVERNING BODY	STANDARD CODE
UL	1666 (OFNR) 1685 (OFNG-LS)
ANSI/ICEA	S-83-596
IEC	60794-1-22
EU	EN 13501-6 (CPR)

Contact AFL for further details.



LM-Series OSP MicroCore® Cable

AFL OSP MicroCore® cable series (LM-Series) is designed for outside plant installation in microduct conduit systems. The foundation of the design is the multi-fiber-set, gel-filled buffer tube construction. The kink-resistant buffer tube contains multiple 12-fiber sets of color-coded fibers. Each set within the buffer tube is grouped using dual color-coded binder threads. The dry-blocked core is made up of SZ-stranded buffer tubes around a central strength member. The low-friction, high-strength overall jacketing system protects the cable-core while providing an optimized cable package supporting high-speed, long-distance jetting performance. The unique, high-fiber density geometry yields a cable construction that can accommodate up to 432 fibers and can be blown into microducts ranging in inside diameters from 10 mm to 16 mm.

Features

- 12 up to 432 250 µm fibers
- Low-friction outer jacket designed for air-blown installations
- Robust, kink-resistant buffer tubes reduce time and handling issues associated with enclosure build-outs
- 300lb installation tensile load rating
- OD compatible with 10 mm to 16 mm inside diameter microducts

Applications

- Long-haul, middle-mile and metro-loop
- Campus inter-building backbone distribution
- Low-cost fiber upgrade migration strategies

Cable Components

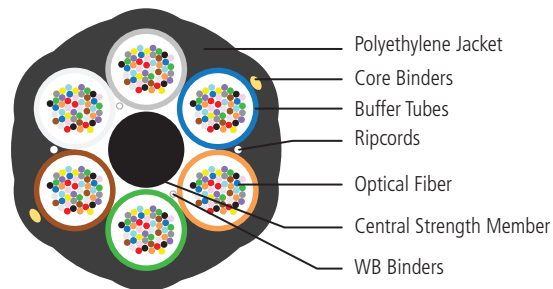

continued
→

LM-Series OSP MicroCore® Cable

Physical and Mechanical Data

LM-SERIES AFL NO.*	FIBER COUNT	FIBERS/ NUMBER OF TUBES**	DIAMETER		WEIGHT LBS/1000FT (KG/KM)	MAXIMUM TENSILE LOAD LBS (N)		MINIMUM BEND RADIUS INCHES (CM)	
			INCHES (MM)	INCHES (MM)		INSTALLATION	OPERATION	INSTALLATION	OPERATION
LM012xC6101NS	12	12/1 (5 fillers)	0.31 (7.9)	0.39 (10.0)	31 (46)	300 (1334)	90 (400)	6.5 (16)	5 (12)
LM024xC6101NS	24	12/2 (4 fillers)	0.31 (7.9)	0.39 (10.0)	32 (48)	300 (1334)	90 (400)	6.5 (16)	5 (12)
LM048xC6101NS	48	12/4 (2 fillers)	0.31 (7.9)	0.39 (10.0)	33 (49)	300 (1334)	90 (400)	6.5 (16)	5 (12)
LM072xC6101NS	72	12/6	0.31 (7.9)	0.39 (10.0)	34 (51)	300 (1334)	90 (400)	6.5 (16)	5 (12)
LM096xO6101NS	96	24/4 (2 fillers)	0.31 (7.9)	0.39 (10.0)	34 (51)	300 (1334)	90 (400)	6.5 (16)	5 (12)
LM144xO6101NS	144	24/6	0.31 (7.9)	0.39 (10.0)	36 (53)	300 (1334)	90 (400)	6.5 (16)	5 (12)
LM288xR6101NS	288	48/6	0.41 (10.4)	0.51 (13.0)	63 (93)	300 (1334)	90 (400)	8.5 (21)	6.5 (16)
LM432xOI301NS	432	24/18	0.50 (12.6)	0.63 (16.0)	87 (130)	300 (1334)	90 (400)	10 (26)	7.5 (19)

* Replace "x" in AFL number with Fiber Identifier in the Fiber Specifications table below.

** Fibers are arranged in 12-fiber sets identified by colored binder threads. For fiber identification details [click here](#).

Optical Fiber Options

FIBER TYPE	"X"	STANDARD	MODE FIELD DIAMETER	ATTENUATION	
				1300 nm	1550 nm
250 µm Single-mode	9	ITU-T G.652D / 657.A1	9.2 µm nominal	0.35	0.25
Corning 250 µm Single-mode	AZ	ITU-T G.652D / 657.A1	9.2 µm nominal	0.35	0.25

Standard Packaging Details

FIBER COUNT	REEL DIMENSIONS (FLANGE X WIDTH)	STANDARD REEL LENGTH	TYPICAL TOTAL WEIGHT
12-144	48 x 36 in.	20,000 ft (6,096 m)	950 lbs (430 kg)
288	58 x 38 in.	20,000 ft (6,096 m)	1,800 lbs (816 kg)
432	66 x 42 in.	20,000 ft (6,096 m)	2,450 lbs (1,111 kg)

Recommended Products

DESCRIPTION	AFL NO.
Apex® X-2 Sealed Splice Closure	Refer to spec sheet for AFL No.
Apex® X-2S Sealed Splice Closure	Refer to spec sheet for AFL No.
FUSEConnect® MPO Splice-on Connectors	Refer to spec sheet for AFL No.
FUSEConnect® Field-installable Splice-on Connectors	Refer to spec sheet for AFL No.
LMHD-Series OSP MicroCore® Cable	Refer to spec sheet for AFL No.
Poli-MOD® Patch and Splice Module	Refer to spec sheet for AFL No.

Temperature Specifications

TEMPERATURE RANGE	
OPERATION	-30°C to +70°C
STORAGE	-30°C to +70°C
INSTALLATION	-10°C to +60°C

Qualifications

GOVERNING BODY	STANDARD CODE	COMPONENT
ANSI/ICEA	S-122-744	Cable
TIA	598-D	Fiber

Contact AFL for further details.



LM200-Series OSP MicroCore® Cable

The product design integrates 200 µm buffered single-mode fiber which allows for reduced diameter cables compared to traditional OSP micro-cables. The foundation of the design is the multi-fiber-set, gel-filled buffer tube construction. The kink-resistant buffer tube contains multiple 12-fiber sets of color-coded fibers. Each set within the buffer tube is grouped using dual color-coded binder threads. The dry-blocked core is made up of six buffer tubes SZ-stranded around a central strength member. The low-friction, high-strength overall jacketing system protects the cable-core while providing an optimized cable package supporting high-speed, long-distance jetting performance. The LM200-Series is the right choice for use in bundled micro-duct pathways allowing for future, incremental cable additions as network circuits and bandwidth requirements increase.

Features

- 24 to 432 fibers
- Robust, kink-resistant buffer tubes reduce time and handling issues associated with enclosure build-outs
- Low-friction jacketing system allows for longer jetting distances
- Designed for use in bundled micro-duct pathways allowing for future, optical circuit additions

Applications

- Long-haul, Local Loop FTTx, Campus Backbone connections for 10G, 40G, and 100G network transmission speeds
- Air-jetted into bundled micro-ducts
- Congested pathway over-ride installations

Cable Components

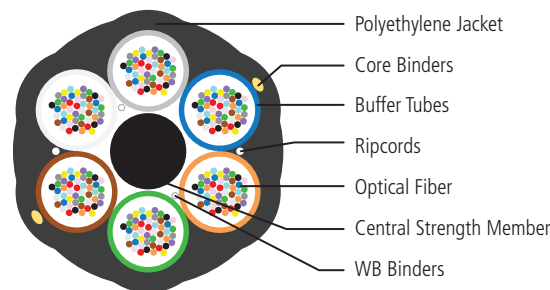

continued
→

LM200-Series OSP MicroCore® Cable

Physical and Mechanical Data

LM200-SERIES AFL NO.*	FIBER COUNT	FIBERS/ NUMBER OF TUBES**	DIAMETER		WEIGHT LBS/1000FT (KG/KM)	MAXIMUM TENSILE LOAD LBS (N)		MINIMUM BEND RADIUS INCHES (CM)	
			INCHES (MM)	INCHES (MM)		INSTALLATION	OPERATION	INSTALLATION	OPERATION
LM024xO6101NS	24	24/1 (5 fillers)	0.248 (6.3)	0.315 (8)	21 (31)	200 (890)	60 (267)	5 (13)	4 (10)
LM048xO6101NS	48	24/2 (4 fillers)	0.248 (6.3)	0.315 (8)	22 (33)	200 (890)	60 (267)	5 (13)	4 (10)
LM072xO6101NS	72	24/3 (3 fillers)	0.248 (6.3)	0.315 (8)	23 (34)	200 (890)	60 (267)	5 (13)	4 (10)
LM096xO6101NS	96	24/4 (2 fillers)	0.248 (6.3)	0.315 (8)	24 (36)	200 (890)	60 (267)	5 (13)	4 (10)
LM144xO6101NS	144	24/6	0.248 (6.3)	0.315 (8)	26 (39)	200 (890)	60 (267)	5 (13)	4 (10)
LM288xR6101NS	288	48/6	0.319 (8.1)	0.394 (10)	43 (65)	300 (1334)	90 (400)	6.5 (17)	5 (13)
LM432xT6101NS	432	72/6	0.409 (10.4)	0.512 (13)	70 (104)	300 (1334)	90 (400)	8.5 (21)	6.5 (16)

* "x" denotes fiber type. See optical fiber specification table to complete AFL part number.

** Fibers are arranged in 12-fiber sets identified by colored binder threads. For fiber identification details [click here](#).

Optical Fiber Specifications

FIBER TYPE	"X"	STANDARD	MODE FIELD DIAMETER	ATTENUATION	
				1300 nm	1550 nm
200 µm Single-mode	BC	ITU-T G.652.D / 657.A1	9.2 µm nominal	0.35	0.25
Corning 200 µm Single-mode	BA	ITU-T G.652.D / 657.A1	9.2 µm nominal	0.35	0.25

Standard Packaging Details

FIBER COUNT	REEL DIMENSIONS (Flange x Width)	STANDARD REEL LENGTH	REEL WEIGHT	TYPICAL TOTAL WEIGHT
24-288	48 x 36 in.	19,000 ft (5,791 m)	140 lbs (64 kg)	1,100 lbs (500 kg)
432	58 x 38 in.	19,000 ft (5,791 m)	435 lbs (197 kg)	1,900 lbs (862 kg)

Recommended Products

DESCRIPTION	AFL NO.
Apex® X-2 Sealed Splice Closure	Refer to spec sheet for AFL No.
Apex® X-2S Sealed Splice Closure	Refer to spec sheet for AFL No.
Poli-MOD® Patch and Splice Module	Refer to spec sheet for AFL No.
FUSEConnect® MPO Splice-on Connectors	Refer to spec sheet for AFL No.
FUSEConnect® Field-installable Splice-on Connectors	Refer to spec sheet for AFL No.

Temperature Specifications

TEMPERATURE RANGE	
OPERATION	-30°C to +70°C
STORAGE	-30°C to +70°C
INSTALLATION	-10°C to +60°C

Qualifications

GOVERNING BODY	STANDARD CODE	COMPONENT
ANSI/ICEA	S-122-744	Cable
TIA	598-D	Fiber

Contact AFL for further details.

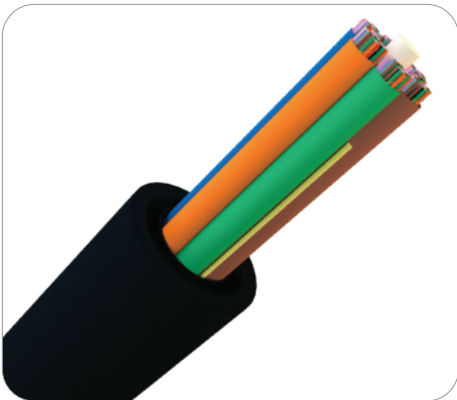

LMHD-Series OSP Heavy Duty MicroCore® Cable

The Heavy Duty OSP MicroCore® (LMHD-Series) is small-diameter loose tube fiber optic cable with a 600lb load-rating. The design consists of SZ-stranded gel-filled buffer tubes, aramid and fiberglass strength elements, and a thick-walled, UV-resistant outer jacket. These cables can be jetted or pulled into standard HDPE ducts and, because of their small diameters, can be jetted into bundled microduct pathways. Minimum pathway inside diameters range from 13 mm to 20 mm, varied by the cable fiber count. When the application requires a transition from underground to aerial, the LMHD-Series cables can be lashed to aerial messenger wires using standard OSP cable lashing equipment and techniques.

Features

- 12 up to 432 250 μm fibers
- 600 lb tensile load rating for pulling applications to be comparable to traditional underground loose tube fiber optic cables but at a smaller size
- Small-diameter construction offers improved air-jetting when compared to conventional loose tube cables
- Thick-walled outer jacket capable of direct lashing to aerial messenger wires
- Toneable option includes a low-resistance copper wire that allows cable/pathway to be located using standard electromagnetic detector devices

Applications

- Long-haul, local loop FTTx, campus backbone connections for 10G, 40G and 100G network transmission speeds
- Air-jetted into bundled micro-ducts
- Congested pathway over-ride installations

Cable Components

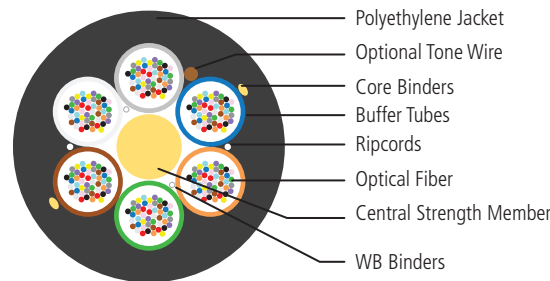

continued
→

LMHD-Series OSP Heavy Duty MicroCore® Cable

Physical and Mechanical Data

LMHD-SERIES AFL NO.*	FIBER COUNT	FIBERS/ NUMBER OF TUBES**	DIAMETER		MIN. MICRODUCT INNER DIAMETER	WEIGHT*** LBS/1000FT (KG/KM)	MAXIMUM TENSILE LOAD		MINIMUM BEND RADIUS	
			INCHES (MM)	INCHES (MM)			LBS (N)		INCHES (CM)	
							INSTALLATION	OPERATION	INSTALLATION	OPERATION
LM012xC6201#1	12	12/1 (5 fillers)	0.40 (10.1)	0.512 (13)	53 (78)	600 (2670)	180 (801)	8 (20)	6 (15)	
LM024xC6201#1	24	12/2 (4 fillers)	0.40 (10.1)	0.512 (13)	53 (79)	600 (2670)	180 (801)	8 (20)	6 (15)	
LM048xC6201#1	48	12/4 (2 fillers)	0.40 (10.1)	0.512 (13)	54 (81)	600 (2670)	180 (801)	8 (20)	6 (15)	
LM072xC6201#1	72	12/6	0.40 (10.1)	0.512 (13)	56 (83)	600 (2670)	180 (801)	8 (20)	6 (15)	
LM096xO6201#1	96	24/4 (2 fillers)	0.40 (10.1)	0.512 (13)	56 (83)	600 (2670)	180 (801)	8 (20)	6 (15)	
LM144xO6201#1	144	24/6	0.40 (10.1)	0.512 (13)	57 (85)	600 (2670)	180 (801)	8 (20)	6 (15)	
LM288xR6201#1	288	48/6	0.49 (12.4)	0.630 (16)	86 (129)	600 (2670)	180 (801)	10 (25)	7.5 (19)	
LM432xOI201#1	432	24/18	0.58 (14.6)	0.787 (20)	117 (174)	600 (2670)	180 (801)	12 (30)	9 (22)	

- * Replace # with "N" for all-dielectric cable or "T" for toneable option. "x" denotes fiber type. See Optical Fibers Options table below.
- ** Fibers are arranged in 12-fiber sets identified by colored binder threads. For fiber identification details [click here](#).
- *** Weights provided for all-dielectric designs, toneable cables will have a slightly increased weight. Contact AFL for details.

Optical Fiber Options

FIBER TYPE	"X"	STANDARD	MODE FIELD DIAMETER	ATTENUATION	
				1300 nm	1550 nm
250 µm Single-mode	9	ITU-T G.652D / 657.A1	9.2 µm nominal	0.35	0.25
Corning 250 µm Single-mode	AZ	ITU-T G.652D / 657.A1	9.2 µm nominal	0.35	0.25

Standard Packaging Details

Typical cut lengths are 20,000ft or 30,000ft. Contact AFL for longer or other preferred cut lengths.

FIBER COUNT	REEL DIMENSIONS (Flange x Width)	STANDARD REEL LENGTH	TYPICAL TOTAL WEIGHT
12-72	58 x 38 in.	20,000 ft (6,096 m)	1,450 lbs (658 kg)
96-144	58 x 38 in.	20,000 ft (6,096 m)	1,750 lbs (794 kg)
288	66 x 42 in.	20,000 ft (6,096 m)	2,400 lbs (1,089 kg)
432	72 x 42 in.	20,000 ft (6,096 m)	3,150 lbs (1,429 kg)

FIBER COUNT	REEL DIMENSIONS (Flange x Width)	STANDARD REEL LENGTH	TYPICAL TOTAL WEIGHT
12-72	66 x 42 in.	30,000 ft (9,144 m)	2,100 lbs (953 kg)
96-144	66 x 42 in.	30,000 ft (9,144 m)	2,500 lbs (1,134 kg)
288	72 x 42 in.	30,000 ft (9,144 m)	3,500 lbs (1,588 kg)

Recommended Products

DESCRIPTION	AFL NO.
Apex® X-2 Sealed Fiber Optic Splice Closure	Refer to spec sheet for AFL No.
Apex® X-2S Sealed Fiber Optic Splice Closure	Refer to spec sheet for AFL No.
Poli-MOD® Patch and Splice Module	Refer to spec sheet for AFL No.
FUSEConnect® Field-installable Splice-on Connectors	Refer to spec sheet for AFL No.
FUSEConnect® MPO Splice-on Connectors	Refer to spec sheet for AFL No.
LM-Series OSP MicroCore® Cable	Refer to spec sheet for AFL No.

Qualifications

GOVERNING BODY	STANDARD CODE	COMPONENT
Telcordia	GR-20-CORE	Cable*
ICEA	640	Cable
TIA	598-D	Fiber

* Tested to the operating temperature range as specified

Temperature Specifications

TEMPERATURE RANGE	
STORAGE	-30°C to +75°C
INSTALLATION	-10°C to +40°C
OPERATION	-30°C to +70°C

Contact AFL for further details.

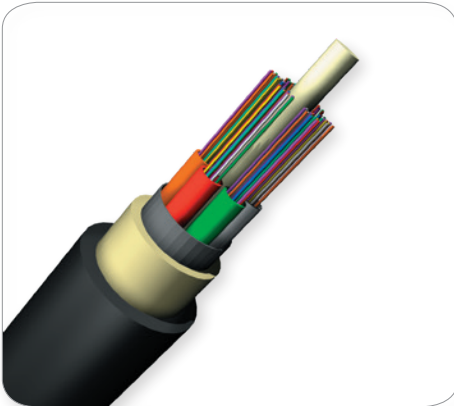

LV-Series Indoor/Outdoor Riser Loose Tube – Single Jacket

Indoor/outdoor stranded loose tube combines the robust mechanical and environmental characteristics of an outside plant cable with the flexibility of an inside plant riser cable. By installing an indoor/outdoor stranded loose tube, splice locations entering into a building are avoided, being routed directly from the outside plant to telecommunications closets, or main distribution frames (MDF) through the riser of a building and eliminating the “50-foot rule.” Indoor/Outdoor Stranded Design loose tube cable is moisture and U.V. resistant and is SZ stranded to allow slack for mid-span access.

Features

- Fiber counts up to 144
- Compact design
- Gel-filled or gel-free tubes are reverse-oscillated (SZ stranded) to allow slack for mid-span access

Applications

- Underground Duct
- Long Haul Networking
- Building Interconnections (Campus LAN)
- Trunking Lines Direct to Telecommunications Closet
- Local Loop
- Intrabuilding Backbones
- Distance Learning

Typical Lengths

FIBER COUNT	MAXIMUM LENGTHS*			
	SINGLE-MODE		MULTIMODE	
	feet	meters	feet	meters
6-144	22,900	7,000	22,900	7,000

* Longer lengths may be available.

Cable Components

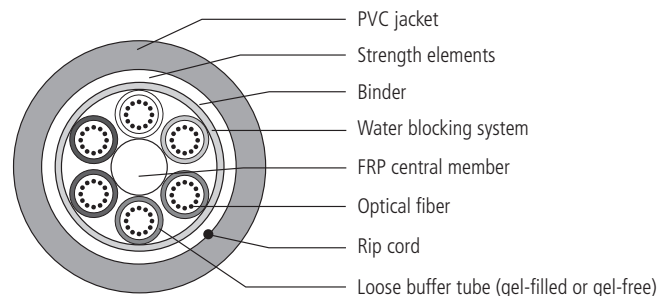

Fiber Specifications

CORE SIZE/FIBER TYPE	AFL FIBER IDENTIFIER	ISO/IEC	MAXIMUM ATTENUATION (dB/km)				OVERFILL LAUNCH MIN. BANDWIDTH (MHz•km)		GIGABIT ETHERNET MAX. LINK DISTANCE (meters)	
			850 nm	1300 nm	1310 nm	1550 nm	850 nm	1300 nm	850 nm	1300 nm
62.5/125 GIGA-Link™ 300	6	OM1	3.5	1.2	N/A	N/A	200	600	300	550
50/125 GIGA-Link™ 600	5	OM2	3.5	1.5	N/A	N/A	500	500	600	600
50/125 Laser-Link™ 300	L	OM3	3.0	1.2	N/A	N/A	1500	500	1000	550
50/125 Laser-Link™ 300	C	OM4	3.0	1.2	N/A	N/A	3500	500	1040	550
Single-mode (ITU G.652.D/G.657.A1)	9	OS2	N/A	N/A	0.35	0.25	N/A	N/A	N/A	N/A
Corning Single-mode (ITU G.652.D/G.657.A1)	AZ	OS2	N/A	N/A	0.35	0.25	N/A	N/A	N/A	N/A

Gigabit Ethernet Minimum Link Distances are based on “bandwidth”/modal dispersion constraints. Actual link distances may be constrained by attenuation, depending on specific loss budget.

continued
→



LV-Series Indoor/Outdoor Riser Loose Tube – Single Jacket

Ordering Information

AFL NO.	FIBER COUNT	NUMBER OF TUBES/FIBERS	NOMINAL DIAMETER		NOMINAL WEIGHT		MAXIMUM TENSILE LOAD		MINIMUM BEND RADIUS	
			inches (mm)	lbs/1,000 ft (kg/km)	lbs (N)		inches (cm)			
					SHORT TERM	LONG TERM	SHORT TERM	LONG TERM		
GEL-FILLED										
LV012★C5101N1	12	1w/12 (4 fillers)	0.51 (12.9)	108 (160)	600 (2700)	200 (890)	10.2 (26)	7.7 (20)		
LV024★C5101N1	24	2w/12 (3 fillers)	0.51 (12.9)	108 (161)	600 (2700)	200 (890)	10.2 (26)	7.7 (20)		
LV036★C5101N1	36	3w/12 (2 fillers)	0.51 (12.9)	109 (162)	600 (2700)	200 (890)	10.2 (26)	7.7 (20)		
LV048★C5101N1	48	4w/12 (1 filler)	0.51 (12.9)	110 (164)	600 (2700)	200 (890)	10.2 (26)	7.7 (20)		
LV060★C5101N1	60	5w/12 (No fillers)	0.51 (12.9)	111 (165)	600 (2700)	200 (890)	10.2 (26)	7.7 (20)		
LV072★C6101N1	72	6w/12 (No fillers)	0.54 (13.7)	128 (190)	600 (2700)	200 (890)	10.8 (28)	8.1 (21)		
LV096★C8101N1	96	8w/12 (No fillers)	0.61 (15.5)	159 (237)	600 (2700)	200 (890)	12.2 (31)	9.2 (24)		
LV144★CC101N1	144	12w/12 (No fillers)	0.76 (19.3)	243 (361)	600 (2700)	200 (890)	15.2 (39)	11.4 (29)		
GEL-FREE										
LV012★C5101N1D	12	1/12 (4 fillers)	0.48 (12.3)	100 (148)	600 (2670)	180 (800)	9.7 (25)	7.2 (19)		
LV024★C5101N1D	24	2/12 (3 fillers)	0.48 (12.3)	99 (146)	600 (2670)	180 (800)	9.7 (25)	7.2 (19)		
LV036★C5101N1D	36	3/12 (2 fillers)	0.48 (12.3)	99 (147)	600 (2670)	180 (800)	9.7 (25)	7.2 (19)		
LV048★C5101N1D	48	4/12 (1 filler)	0.48 (12.3)	99 (147)	600 (2670)	180 (800)	9.7 (25)	7.2 (19)		
LV060★C5101N1D	60	5/12 (no fillers)	0.48 (12.3)	98 (146)	600 (2670)	180 (800)	9.7 (25)	7.2 (19)		
LV072★C6101N1D	72	6/12 (no fillers)	0.52 (13.1)	103 (154)	600 (2670)	180 (800)	10.3 (26)	7.8 (20)		
LV096★C8101N1D	96	8/12 (no fillers)	0.58 (14.7)	138 (205)	600 (2670)	180 (800)	11.6 (29)	8.7 (23)		
LV144★CC101N1D	144	12/12 (no fillers)	0.72 (18.2)	198 (295)	600 (2670)	180 (800)	14.3 (37)	10.8 (28)		

Note: Diameter and weight subject to change without notice

★ Fiber Types – Replace asterisk (★) in AFL number with AFL Fiber Identifier in the Fiber Specifications table on previous page.

Reel Information

ITEM	REEL A		REEL B		REEL C		REEL D		REEL E	
	inches	cm	inches	cm	inches	cm	inches	cm	inches	cm
Reel Height	42	106.7	58	147.3	66	167.6	72	182.8	84	213.4
Reel Width Outside	36	91.4	38	96.5	42	106.7	42	106.7	40	101.6
Reel Width Inside	32	81.6	32	81.3	36	91.4	36	91.4	34	86.4
Drum Diameter	23	58.7	28	71.1	36	91.4	36	91.4	35	88.9
Arbor Hole Diameter	3	7.9	3	7.9	3	7.9	3	7.9	3	7.9
Reel Weight With Lagging	180 lbs	82 kg	420 lbs	191 kg	685 lbs	311 kg	710 lbs	320 kg	950 lbs	431 kg

AFL typically provides Loose Tube cable on several standard sizes of non-returnable wooden reels. Non-standard reel sizes are available upon request.

Larger reel sizes may be required to accommodate long cable lengths.

Qualifications

GOVERNING BODY	STANDARD CODE	COMPONENT
Telcordia	GR-20-CORE	Cable
UL	1666 (OFNR)	Cable
ICEA	S-104-696	Cable
CSA	22.2 (FT4)	Cable
TIA	598-D	Fiber

Temperature Specifications

TEMPERATURE RANGE	
OPERATION	-40°C to +70°C
STORAGE	-40°C to +70°C
INSTALLATION	-30°C to +70°C

Contact AFL for your customized cable solution.

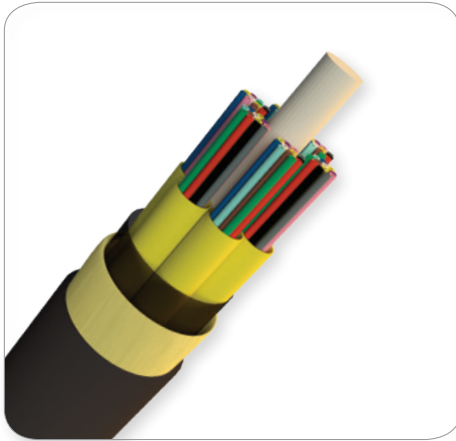

LQ-Series Plenum-rated Indoor/Outdoor Loose Tube

The LQ-Series I/O plenum-rated fiber optic loose tube cables are designed to reduce network cabling costs by eliminating the need to use different cables within a pathway that includes outside plant (OSP) and inside plant (ISP) segments. This dual rating allows for the LQ-Series cable to be transitioned from the OSP pathway and routed within the building space without the need to splice to a separate flame-rated cable installed in a protective conduit. This feature saves space, material costs and installation time.

The cable construction consists of 12-fiber, gel-free buffer tubes stranded around a central strength member. The finished core is jacketed with a highly flame-retardant, UV-resistant thermoplastic. The LQ-Series cable is available with 12 up to 144 single-mode or multimode fibers.

Applications

- Inter-building campus backbone connections
- Suitable for installing in OSP buried pathways or above-ground exposed cable trays
- Cable routes that require cables to transit OSP spaces and inside plant environments that require cables to be riser or plenum rated

Fiber Specifications

FIBER TYPE	ISO/IEC	AFL FIBER IDENTIFIER	MAXIMUM ATTENUATION (dB/km)			OVERFILL LAUNCH MIN. BANDWIDTH (MHz•km)		EMBC (MHz•km)	GIGABIT ETHERNET MAX. LINK DISTANCE (meters)		10 GIGABIT ETHERNET MAX. LINK DISTANCE (meters)	
			850 nm	1310 nm	1550 nm	850 nm	1310 nm		850 nm	1300 nm	850 nm	1300 nm
62.5 Giga-Link™ 300	OM1	6	3.5	1.2	N/A	200	600	N/A	300	550	32	—
50 Giga-Link™ 600	OM2	5	3.5	1.5	N/A	500	500	N/A	600	600	82	—
50 Laser-Link 300	OM3	L	3.0	1.2	N/A	1,500	500	2,000	1,000	550	300	—
50 Laser-Link 550	OM4	C	3.0	1.2	N/A	3,500	500	4,700	1,040	550	550	—
Single-mode (ITU G.652.D/G.657.A1)	OS2	9	N/A	0.4	0.3	N/A	N/A	N/A	N/A	5,000	N/A	10,000

continued
→

LQ-Series — Plenum-rated Indoor/Outdoor Loose Tube

Mechanical Data

AFL NO.	FIBER COUNT	DIAMETER inches (mm)	WEIGHT lbs/1000ft (kg/km)	SHORT-TERM/INSTALLATION		LONG-TERM/STATIC	
				MAX TENSILE LOAD lbs (N)	MIN BEND RADIUS inches (cm)	MAX TENSILE LOAD lbs (N)	MIN BEND RADIUS inches (cm)
LQ012*3018#B:C4C	12	0.39 (10.0)	62 (92)	300 (1334)	5.9 (15)	90 (400)	3.9 (10)
LQ024*3018#B:C4C	24	0.39 (10.0)	62 (93)	300 (1334)	5.9 (15)	90 (400)	3.9 (10)
LQ036*3018#B:C4C	36	0.39 (10.0)	63 (94)	300 (1334)	5.9 (15)	90 (400)	3.9 (10)
LQ048*3018#B:C4C	48	0.39 (10.0)	64 (95)	300 (1334)	5.9 (15)	90 (400)	3.9 (10)
LQ072*3018#B:C6C	72	0.46 (11.8)	91 (135)	600 (2669)	7.0 (18)	180 (801)	4.6 (12)
LQ096*3018#B:C8C	96	0.54 (13.6)	125 (185)	600 (2669)	8.0 (21)	180 (801)	5.4 (14)
LQ144*3018#B:CCC	144	0.69 (17.5)	220 (315)	600 (2669)	10.4 (26)	180 (801)	6.9 (18)

* Fiber Types – Replace asterisk (*) in AFL number with number in the Fiber Specifications table on previous page.

Subunit Jacket Color – Replace hashtag (#) in AFL number with number in the Cable Jacket Color table below.

Cable Jacket Color Options

1 - Blue	8 - Black
2 - Orange	9 - Yellow
3 - Green	A - Violet
4 - Brown	B - Rose
5 - Slate	C - Aqua
6 - White	K - Erika Violet (RAL 4003)
7 - Red	

Qualifications

GOVERNING BODY	STANDARD CODE	COMPONENT
Telcordia	GR-20-CORE, Issue 4	Fiber, Cable
ICEA	S-104-696, 2013	Cable
UL	444	Outer Jacket
NEC	OFNP, CSA FT-6	Cable

Temperature Specifications

TEMPERATURE RANGE	
OPERATION	-40°C to +70°C
STORAGE	-40°C to +70°C
INSTALLATION	-15°C to +60°C

Contact AFL for your customized cable solution.

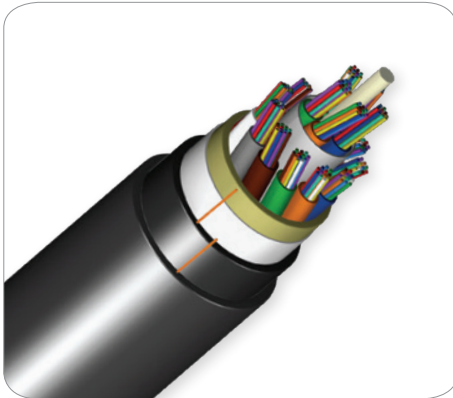

All-Dielectric Armored Rodent-Resistant OSP Loose Tube (LN Series)

AFL's All-dielectric Rodent-Resistant cable is designed for environments that have an increased risk of rodent infestation and disturbance. The LN-series product line covers the range of fiber counts of up to 432 fibers. The ultra-hard, non-metallic outer polymer shell reduces the risk of transmission interruptions in vital OSP network interconnections.

Features

- Fiber counts up to 432
- All-dielectric Armor
- Double jacket design provides additional protection to the fibers
- Gel-filled tubes are reverse-oscillated (SZ stranded) to allow slack for mid-span access

Applications

- Direct Buried
- Long Haul Networking
- Building Interconnections (Campus LAN)
- Steam-tunnel Substreet Drainage Networks
- Airport (FAA-E-2761c, Type B)

Typical Lengths

FIBER COUNT	MAXIMUM LENGTHS*			
	SINGLE-MODE		MULTIMODE	
	FEET	METERS	FEET	METERS
6 - 60	22,900	7,000	22,900	8,000
72 - 96	22,900	7,000	22,900	7,000
108 - 120	22,900	7,000	22,900	7,000
132 - 144	22,600	6,900	22,600	6,900
146 - 216	17,000	5,200	17,000	5,200
218 - 288	15,000	4,600	15,000	4,600
290 - 432	10,800	3,300	10,800	3,300

* Longer lengths may be available upon request.

Cable Components

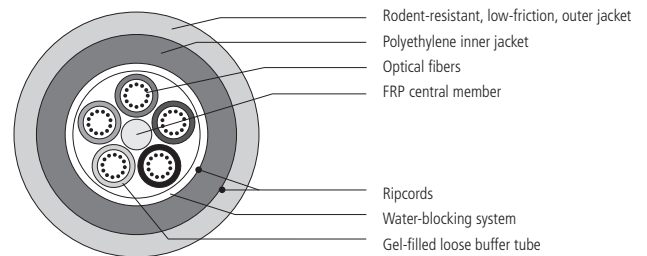

Fiber Specifications

FIBER TYPE	MAXIMUM ATTENUATION (DB/KM)				OVERFILL LAUNCH MIN. BANDWIDTH (MHZ•KM)		GIGABIT ETHERNET MIN. LINK DISTANCE (METERS)	
	850 NM	1300 NM	1310 NM	1550 NM	850 NM	1300 NM	850 NM	1300 NM
(6) 62.5/125 GIGA-Link™ 300	3.5	1.2	N/A	N/A	200	600	300	550
(5) 50/125 GIGA-Link™ 600	2.9	0.9	N/A	N/A	500	500	600	600
(L) 50/125 Laser-Link™ 300	2.9	0.9	N/A	N/A	1500	500	900	550
(9) Single-mode	N/A	N/A	0.35	0.25	N/A	N/A	N/A	5000
(Q) Non-zero Dispersion-shifted Single-mode	N/A	N/A	N/A	0.25	N/A	N/A	N/A	N/A

Gigabit Ethernet Minimum Link Distances are based on "bandwidth"/modal dispersion constraints. Actual link distances may be constrained by attenuation, depending on specific loss budget.

continued
→



All-Dielectric Armored Rodent-Resistant OSP Loose Tube (LN Series)

Ordering Information

AFL NO.	FIBER COUNT	NUMBER OF TUBES/FIBERS	NOMINAL DIAMETER		NOMINAL WEIGHT		MAXIMUM TENSILE LOAD		MINIMUM BEND RADIUS	
			INCHES	MM	LBS/1,000FT	KG/KM	LBS (N)		INCHES (CM)	
							SHORT TERM	LONG TERM	SHORT TERM	LONG TERM
LN006★C5101N1	6	1w/6 (4 fillers)	0.49	12.5	56	84	600 (2670)	200 (890)	9.8 (25)	7.4 (19)
LN012★C5101N1	12	1w/12 (4 fillers)	0.49	12.5	56	84	600 (2670)	200 (890)	9.8 (25)	7.4 (19)
LN018★C5101N1	18	1w/12,1w/6 (3 fillers)	0.49	12.5	56	84	600 (2670)	200 (890)	9.8 (25)	7.4 (19)
LN024★C5101N1	24	2w/12 (3 fillers)	0.49	12.5	56	84	600 (2670)	200 (890)	9.8 (25)	7.4 (19)
LN030★C5101N1	30	2w/12,1w/6 (2 fillers)	0.49	12.5	56	84	600 (2670)	200 (890)	9.8 (25)	7.4 (19)
LN036★C5101N1	36	3w/12 (2 fillers)	0.49	12.5	56	84	600 (2670)	200 (890)	9.8 (25)	7.4 (19)
LN048★C5101N1	48	4w/12 (1 filler)	0.49	12.5	56	84	600 (2670)	200 (890)	9.8 (25)	7.4 (19)
LN060★C5101N1	60	5w/12 (no fillers)	0.49	12.5	56	84	600 (2670)	200 (890)	9.8 (25)	7.4 (19)
LN072★C6101N1	72	6w/12 (no fillers)	0.53	13.4	65	97	600 (2670)	200 (890)	10.6 (27)	8.0 (21)
LN084★C8101N1	84	7w/12 (1 filler)	0.60	15.2	81	121	600 (2670)	200 (890)	12.0 (31)	9.0 (23)
LN096★C8101N1	96	8w/12 (no fillers)	0.60	15.2	81	121	600 (2670)	200 (890)	12.0 (31)	9.0 (23)
LN108★CA101N1	108	9w/12 (1 filler)	0.67	17.1	101	151	600 (2670)	200 (890)	13.4 (35)	10.1 (26)
LN120★CA101N1	120	10w/12 (no fillers)	0.67	17.1	101	151	600 (2670)	200 (890)	13.4 (35)	10.1 (26)
LN132★CC101N1	132	11w/12 (1 filler)	0.75	19.0	123	184	600 (2670)	200 (890)	15.0 (39)	11.3 (29)
LN144★CC101N1	144	12w/12 (no fillers)	0.75	19.0	123	184	600 (2670)	200 (890)	15.0 (39)	11.3 (29)
LN216★CI301N1	216	18w/12 (no fillers)	0.76	19.3	125	187	600 (2670)	200 (890)	15.2 (39)	11.4 (29)
LN288★OC101N1	288	12w/24 (no fillers)	0.73	18.6	183	272	600 (2670)	200 (890)	14.6 (38)	11.0 (28)
LN432★OI301N1	432	18w/24 (no fillers)	0.72	18.4	181	269	600 (2670)	200 (890)	14.4 (37)	10.8 (28)

Note: Diameter and weight subject to change without notice

★ Fiber Types – Replace asterisk (★) in AFL number with number in the Fiber Specifications table on previous page.

Reel Information

ITEM	REEL A		REEL B		REEL C		REEL D		REEL E	
	INCHES	CM	INCHES	CM	INCHES	CM	INCHES	CM	INCHES	CM
Reel Height	42	106.7	58	147.3	66	167.6	72	182.8	84	213.4
Reel Width Outside	36	91.4	38	96.5	42	106.7	42	106.7	40	101.6
Reel Width Inside	32	81.6	32	81.3	36	91.4	36	91.4	34	86.4
Drum Diameter	23	58.7	28	71.1	36	91.4	36	91.4	35	88.9
Arbor Hole Diameter	3	7.9	3	7.9	3	7.9	3	7.9	3	7.9
Reel Weight With Lugging	180 lbs	82 kg	420 lbs	191 kg	685 lbs	311 kg	710 lbs	320 kg	950 lbs	431 kg

AFL typically provides Loose Tube cable on several standard sizes of non-returnable wooden reels. Non-standard reel sizes are available upon request. Larger reel sizes may be required to accommodate long cable lengths.

Qualifications

GOVERNING BODY	STANDARD CODE	COMPONENT
Telcordia	GR-20-CORE	Cable
ICEA	640	Cable
TIA	598-D	Fiber

Temperature Specifications

TEMPERATURE RANGE	
OPERATION	-40°C to +70°C
STORAGE	-40°C to +75°C
INSTALLATION	-30°C to +70°C

Contact AFL for your customized cable solution.

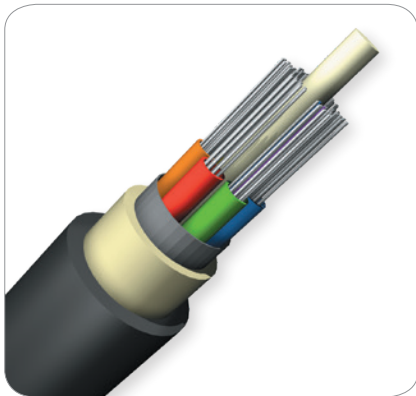

Non-Armored OSP Loose Tube (LE Series SJ)

Acting as the backbone for most of today's fiber based systems, stranded fiber optic cables play a critical role in the high speed network. AFL's Non-Armored Loose Tube fiber optic cables are designed to provide high fiber counts up to 288, which offers the flexibility and versatility required for today's standard installations.

Features

- Up to 288 fibers in cable
- Compact design
- Gel-filled tubes are reverse-oscillated (SZ stranded) to allow slack for mid-span access

Applications

- Distribution
- Underground Duct
- Long Haul Networking
- Building Interconnections (Campus LAN)
- Trunking Lines Direct to Telecommunications Closet
- Local Loop
- Distance Learning
- Intra-building Backbone

Cable Components

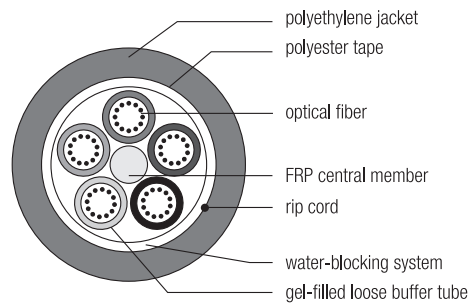

Fiber Specifications

CORE SIZE/FIBER TYPE	AFL FIBER IDENTIFIER	ISO/IEC	MAXIMUM ATTENUATION (dB/km)				OVERFILL LAUNCH MIN. BANDWIDTH (MHz•km)		GIGABIT ETHERNET MIN. LINK DISTANCE (meters)	
			850 nm	1300 nm	1310 nm	1550 nm	850 nm	1300 nm	850 nm	1300 nm
62.5/125 GIGA-Link™ 300	6	OM1	3.5	1.2	N/A	N/A	200	600	300	550
50/125 GIGA-Link™ 600	5	OM2	3.5	1.5	N/A	N/A	500	500	600	600
50/125 Laser-Link™ 300	L	OM3	3.0	1.2	N/A	N/A	1500	500	1000	550
50/125 Laser-Link™ 300	C	OM4	3.0	1.2	N/A	N/A	3500	500	1040	550
Single-mode (ITU G.652.D/G3657.A1)	9	OS2	N/A	N/A	0.35	0.25	N/A	N/A	N/A	N/A
Corning Single-mode (ITU G.652.D/G3657.A1)	AZ	OS2	N/A	N/A	0.35	0.25	N/A	N/A	N/A	N/A

Gigabit Ethernet Minimum Link Distances are based on "bandwidth"/modal dispersion constraints. Actual link distances may be constrained by attenuation, depending on specific loss budget.

continued
→

Non-Armored OSP Loose Tube (LE Series SJ)

Ordering Information

AFL NO.	FIBER COUNT	NUMBER OF TUBES/FIBERS	NOMINAL DIAMETER		NOMINAL WEIGHT		MAX. TENSILE LOAD		MIN. BEND RADIUS	
			inches	mm	LBS/1,000FT	kg/km	lbs (N)		inches (cm)	
							SHORT TERM	LONG TERM	SHORT TERM	LONG TERM
LE012★C5101N1	12	1w/12 (4 fillers)	0.41	10.5	56	84	600 (2670)	200 (890)	8.2 (21)	6.2 (16)
LE024★C5101N1	24	2w/12 (3 fillers)	0.41	10.5	57	85	600 (2670)	200 (890)	8.2 (21)	6.2 (16)
LE036★C5101N1	36	3w/12 (2 fillers)	0.41	10.5	58	86	600 (2670)	200 (890)	8.2 (21)	6.2 (16)
LE048★C5101N1	48	4w/12 (1 filler)	0.41	10.5	59	87	600 (2670)	200 (890)	8.2 (21)	6.2 (16)
LE060★C5101N1	60	5w/12 (no fillers)	0.41	10.5	60	89	600 (2670)	200 (890)	8.2 (21)	6.2 (16)
LE072★C6101N1	72	6w/12 (no fillers)	0.45	11.5	71	106	600 (2670)	200 (890)	9.0 (22)	6.8 (17)
LE096★C8101N1	96	8w/12 (no fillers)	0.52	13.3	91	136	600 (2670)	200 (890)	10.4 (27)	7.8 (20)
LE144★O6101N1	144	6w/24 (no fillers)	0.45	11.5	71	106	600 (2670)	200 (890)	9.1 (23)	6.8 (17)
LE192★O8101N1	192	8w/24 (no fillers)	0.52	13.3	95	142	600 (2670)	200 (890)	10.4 (27)	7.8 (20)
LE216★OC101N1	216	9w/24 (3 fillers)	0.67	17.0	152	226	600 (2670)	200 (890)	13.4 (34)	10.1 (26)
LE288★OC101N1	288	12w/24 (no fillers)	0.67	17.0	152	226	600 (2670)	200 (890)	13.4 (34)	10.1 (26)

Note: Diameter and weight subject to change without notice

★ Fiber Types – Replace asterisk (★) in AFL number with number in the Fiber Specifications table on previous page.

Reel Information

ITEM	REEL A		REEL B		REEL C		REEL D		REEL E	
	INCHES	CM	INCHES	CM	INCHES	CM	INCHES	CM	INCHES	CM
Reel Height	42	106.7	58	147.3	66	167.6	72	182.8	84	213.4
Reel Width Outside	36	91.4	38	96.5	42	106.7	42	106.7	40	101.6
Reel Width Inside	32	81.6	32	81.3	36	91.4	36	91.4	34	86.4
Drum Diameter	23	58.7	28	71.1	36	91.4	36	91.4	35	88.9
Arbor Hole Diameter	3	7.9	3	7.9	3	7.9	3	7.9	3	7.9
Reel Weight With Lagging	180 lbs	82 kg	420 lbs	191 kg	685 lbs	311 kg	710 lbs	320 kg	950 lbs	431 kg

AFL typically provides Loose Tube cable on several standard sizes of non-returnable wooden reels. Non-standard reel sizes are available upon request. Larger reel sizes may be required to accommodate long cable lengths.

Qualifications

GOVERNING BODY	STANDARD CODE	COMPONENT
Telecordia	GR-20-CORE	CABLE
ICEA	640	CABLE
TIA	598-D	FIBER

Temperature Specifications

TEMPERATURE RANGE	
Operation	-40°C to +70°C
Storage	-40°C to +75°C
Installation	-30°C to +70°C

Contact AFL for cable designs.

Gel-Free Non-Armored OSP Loose Tube (LE Series Gel-Free SJ)

AFL LE-Series Gel-Free Single Jacket fiber optic cables incorporate dry water-absorption technology within the fiber-containing buffer tubes. This results in user-friendly handling of fibers during routing and termination within the splice enclosures.

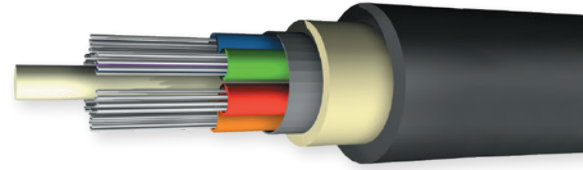

Features

- Fiber counts up to 216
- Gel-free buffer tubes reduce fiber prep termination time
- Reverse-oscillated (SZ stranded) to allow slack for mid-span access
- UV-stabilized outer jacket for long-term performance in aerial applications

Applications

- Distribution
- Underground Duct
- Long Haul Networking
- Building Interconnections (Campus LAN)
- Local Loop
- Lashed Aerial

Typical Lengths

FIBER COUNT	MAXIMUM LENGTHS*	
	SINGLE-MODE	
	feet	meters
12 - 60	22,900	7,000
72 - 96	22,900	7,000
97 - 216	22,900	7,000

* Longer lengths may be available upon request.

Cable Components

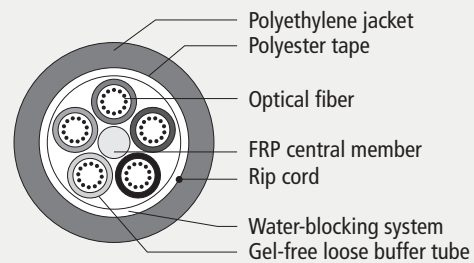

Fiber Specifications

FIBER TYPE	MAXIMUM ATTENUATION (dB/km)				OVERFILL LAUNCH MIN. BANDWIDTH (MHz•km)		GIGABIT ETHERNET MIN. LINK DISTANCE (meters)	
	850 nm	1300 nm	1310 nm	1550 nm	850 nm	1300 nm	850 nm	1300 nm
(9) Single-mode	N/A	N/A	0.35	0.25	N/A	N/A	N/A	5000
(AZ) Corning Single-mode	N/A	N/A	0.35	0.25	N/A	N/A	N/A	5000

Actual link distances may be constrained by attenuation, depending on specific loss budget.

continued
→

Gel-Free Non-Armored OSP Loose Tube (LE Series Gel-Free SJ)

Mechanical Data

AFL NO.	FIBER COUNT	NO. OF TUBES	NOMINAL DIAMETER	NOMINAL WEIGHT	MAXIMUM TENSILE LOAD		MINIMUM BEND RADIUS	
					lbs (N)		Inches (cm)	
					FIBERS/ TUBE	Inches (mm)	lbs/1,000 ft (kg/km)	SHORT TERM
LE012*C5101N1D	12	1/12 (4 fillers)	0.37 (9.5)	44 (65)	600 (2670)	180 (800)	7.4 (19)	5.6 (14)
LE024*C5101N1D	24	2/12 (3 fillers)	0.37 (9.5)	44 (65)	600 (2670)	180 (800)	7.4 (19)	5.6 (14)
LE048*C5101N1D	48	4/12 (1 filler)	0.37 (9.5)	42 (63)	600 (2670)	180 (800)	7.4 (19)	5.6 (14)
LE072*C6101N1D	72	6/12 (no fillers)	0.41 (10.3)	50 (75)	600 (2670)	180 (800)	8.2 (21)	6.2 (16)
LE096*C8101N1D	96	8/12 (no fillers)	0.47 (11.9)	68 (101)	600 (2670)	180 (800)	9.4 (24)	7.1 (18)
LE144*CC101N1D	144	12/12 (no fillers)	0.61 (15.3)	110 (165)	600 (2670)	180 (800)	12.2 (31)	9.2 (22)
LE216*CI301N1D	216	18/12 (no fillers)	0.61 (15.3)	97 (145)	600 (2670)	180 (800)	12.2 (31)	9.2 (22)

Note: Diameter and weight subject to change without notice

* Fiber Types – Replace asterisk (*) in AFL number with number in the Fiber Specifications table on previous page.

Reel Information

ITEM	REEL A		REEL B		REEL C		REEL D		REEL E	
	inches	cm	inches	cm	inches	cm	inches	cm	inches	cm
Reel Height	42	106.7	58	147.3	66	167.6	72	182.8	84	213.4
Reel Width Outside	36	91.4	38	96.5	42	106.7	42	106.7	40	101.6
Reel Width Inside	32	81.6	32	81.3	36	91.4	36	91.4	34	86.4
Drum Diameter	23	58.7	28	71.1	36	91.4	36	91.4	35	88.9
Arbor Hole Diameter	3	7.9	3	7.9	3	7.9	3	7.9	3	7.9
Reel Weight With Lagging	180 lbs	82 kg	420 lbs	191 kg	685 lbs	311 kg	710 lbs	320 kg	950 lbs	431 kg

AFL typically provides Loose Tube cable on several standard sizes of non-returnable wooden reels. Non-standard reel sizes are available upon request.

Larger reel sizes may be required to accommodate long cable lengths.

Qualifications

GOVERNING BODY	STANDARD CODE	COMPONENT
Telcordia	GR-20-CORE	Cable
ICEA	640	Cable
TIA	598-D	Fiber

Temperature Specifications

TEMPERATURE RANGE	
Operation	-40°C to +70°C
Storage	-40°C to +75°C
Installation	-30°C to +70°C

Contact AFL for your customized cable solution.

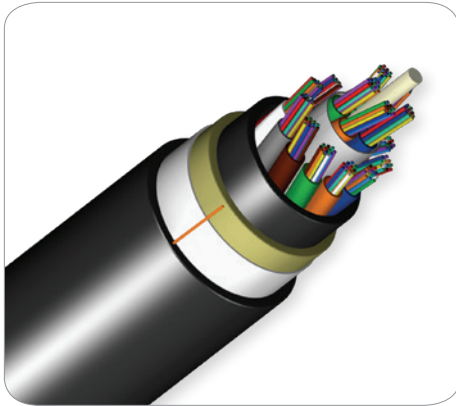

Non-Armored Loose Tube Cable – Double Jacket (LE Series DJ)

Acting as the backbone for most of today’s fiber based systems, stranded fiber optic cables play a critical role in the high speed network. AFL’s Non-Armored Double Jacket Loose Tube fiber optic cables are designed to provide high fiber counts up to 432, which offers the flexibility and versatility required for today’s standard installations.

Features

- Fiber counts up to 432
- Compact design
- Double jacket design provides additional protection to the fibers
- Gel-filled tubes are reverse-oscillated (SZ stranded) to allow slack for mid-span access

Applications

- Distribution
- Underground Duct
- Long Haul Networking
- Building Interconnections (Campus LAN)
- Trunking Lines Direct to Telecommunications Closet
- Local Loop
- Distance Learning
- Intra-building Backbone

Typical Lengths

FIBER COUNT	MAXIMUM LENGTHS*			
	SINGLE-MODE		MULTIMODE	
	FEET	METERS	FEET	METERS
6 - 60	22,900	7,000	22,900	7,000
72 - 96	22,900	7,000	22,900	7,000
108 - 120	22,900	7,000	22,900	7,000
132 - 144	22,900	7,000	22,900	7,000
146 - 216	17,000	5,200	17,000	5,200
218 - 288	15,000	4,600	15,000	4,600
290 - 432	10,800	3,300	10,800	3,300

* Longer lengths may be available upon request.

Cable Components

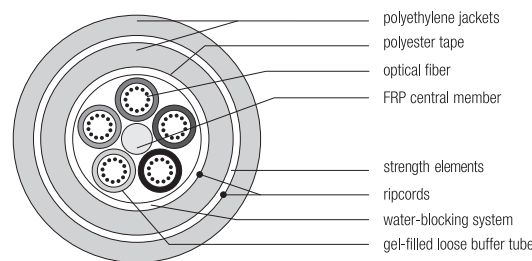

Fiber Specifications

FIBER TYPE	MAXIMUM ATTENUATION (DB/KM)				OVERFILL LAUNCH MIN. BANDWIDTH (MHZ•KM)		GIGABIT ETHERNET MIN. LINK DISTANCE (METERS)	
	850 NM	1300 NM	1310 NM	1550 NM	850 NM	1300 NM	850 NM	1300 NM
	(6) 62.5/125 GIGA-Link™ 300	3.5	1.2	N/A	N/A	200	600	300
(5) 50/125 GIGA-Link™ 600	2.9	0.9	N/A	N/A	500	500	600	600
(L) 50/125 Laser-Link™ 300	2.9	0.9	N/A	N/A	1500	500	900	550
(9) Single-mode	N/A	N/A	0.35	0.25	N/A	N/A	N/A	5000
(Q) Non-zero Dispersion-shifted Single-mode	N/A	N/A	N/A	0.25	N/A	N/A	N/A	N/A
(K) AFL G.657.A1 Single-mode	N/A	N/A	0.35	0.25	N/A	N/A	N/A	5000

Gigabit Ethernet Minimum Link Distances are based on “bandwidth”/modal dispersion constraints. Actual link distances may be constrained by attenuation, depending on specific loss budget.

continued
→



Non-Armored Loose Tube Cable – Double Jacket (LE Series DJ)

Ordering Information

AFL NO.	FIBER COUNT	NUMBER OF TUBES/FIBERS	NOMINAL DIAMETER		NOMINAL WEIGHT		MAXIMUM TENSILE LOAD		MINIMUM BEND RADIUS	
			INCHES	MM	LBS/1,000FT	KG/KM	LBS (N)		INCHES (CM)	
							SHORT TERM	LONG TERM	SHORT TERM	LONG TERM
LE006★C5111N1	6	1w/6 (4 fillers)	0.49	12.5	79	118	600 (2670)	200 (890)	9.8 (25)	7.4 (19)
LE012★C5111N1	12	1w/12 (4 fillers)	0.49	12.5	80	119	600 (2670)	200 (890)	9.8 (25)	7.4 (19)
LE018★C5111N1	18	1w/12, 1w/6 (3 fillers)	0.49	12.5	81	120	600 (2670)	200 (890)	9.8 (25)	7.4 (19)
LE024★C5111N1	24	2w/12 (3 fillers)	0.49	12.5	81	120	600 (2670)	200 (890)	9.8 (25)	7.4 (19)
LE030★C5111N1	30	2w/12, 1w/6 (2 fillers)	0.49	12.5	82	121	600 (2670)	200 (890)	9.8 (25)	7.4 (19)
LE036★C5111N1	36	3w/12 (2 fillers)	0.49	12.5	82	121	600 (2670)	200 (890)	9.8 (25)	7.4 (19)
LE048★C5111N1	48	4w/12 (1 filler)	0.49	12.5	83	123	600 (2670)	200 (890)	9.8 (25)	7.4 (19)
LE060★C5111N1	60	5w/12 (no fillers)	0.49	12.5	84	125	600 (2670)	200 (890)	9.8 (25)	7.4 (19)
LE072★C6111N1	72	6w/12 (no fillers)	0.53	13.4	97	144	600 (2670)	200 (890)	10.6 (27)	8.0 (21)
LE084★C8111N1	84	7w/12 (1 filler)	0.60	15.2	120	178	600 (2670)	200 (890)	12.0 (31)	9.0 (23)
LE096★C8111N1	96	8w/12 (no fillers)	0.60	15.2	121	180	600 (2670)	200 (890)	12.0 (31)	9.0 (23)
LE108★CA111N1	108	9w/12 (1 filler)	0.67	17.1	150	222	600 (2670)	200 (890)	13.4 (34)	10.1 (26)
LE120★CA111N1	120	10w/12 (no fillers)	0.67	17.1	151	224	600 (2670)	200 (890)	13.4 (34)	10.1 (26)
LE132★CC111N1	132	11w/12 (1 filler)	0.75	19.0	184	273	600 (2670)	200 (890)	15.0 (38)	11.3 (29)
LE144★CC111N1	144	12w/12 (no fillers)	0.75	19.0	185	275	600 (2670)	200 (890)	15.0 (38)	11.3 (29)
LE216★CI311N1	216	18w/12 (no fillers)	0.76	19.3	188	280	600 (2670)	200 (890)	15.2 (39)	11.4 (29)
LE288★CO311N1	288	12w/24 (no fillers)	0.75	19.0	188	280	600 (2670)	200 (890)	15.0 (38)	11.3 (29)
LE432★OI311N1	432	18w/24 (no fillers)	0.74	18.8	186	277	600 (2670)	200 (890)	14.8 (38)	11.1 (29)

Note: Diameter and weight subject to change without notice

★ Fiber Types – Replace asterisk (★) in AFL number with number in the Fiber Specifications table on previous page.

Reel Information

ITEM	REEL A		REEL B		REEL C		REEL D		REEL E	
	INCHES	CM	INCHES	CM	INCHES	CM	INCHES	CM	INCHES	CM
Reel Height	42	106.7	58	147.3	66	167.6	72	182.8	84	213.4
Reel Width Outside	36	91.4	38	96.5	42	106.7	42	106.7	40	101.6
Reel Width Inside	32	81.6	32	81.3	36	91.4	36	91.4	34	86.4
Drum Diameter	23	58.7	28	71.1	36	91.4	36	91.4	35	88.9
Arbor Hole Diameter	3	7.9	3	7.9	3	7.9	3	7.9	3	7.9
Reel Weight With Lagging	180 lbs	82 kg	420 lbs	191 kg	685 lbs	311 kg	710 lbs	320 kg	950 lbs	431 kg

AFL typically provides Loose Tube cable on several standard sizes of non-returnable wooden reels. Non-standard reel sizes are available upon request. Larger reel sizes may be required to accommodate long cable lengths.

Qualifications

GOVERNING BODY	STANDARD CODE	COMPONENT
Telcordia	GR-20-CORE	Cable
ICEA	640	Cable
TIA	598-D	Fiber

Temperature Specifications

TEMPERATURE RANGE	
Operation	-40°C to +70°C
Storage	-40°C to +75°C
Installation	-30°C to +70°C

Contact AFL for your customized cable solution.

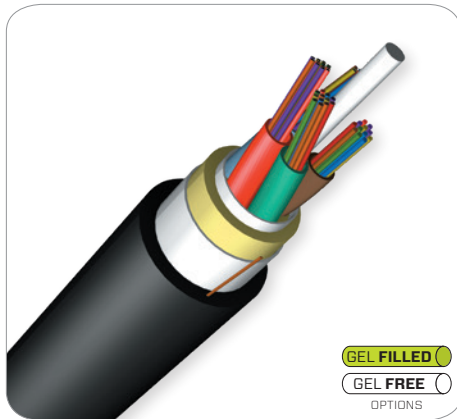

Flex-Span® ADSS Fiber Optic Cable

AFL Flex-Span All-Dielectric Self-Supporting (ADSS) cable is designed for aerial distribution power lines, as well as underground duct applications. As its name indicates, there are no metallic components and the cable does not require a support or messenger wire. Flex-Span ADSS cables are a single jacket design intended for the shorter pole-to-pole span lengths in a distribution environment. A broad combination of fiber counts and spans lengths in this product family provide network designers with flexibility in their cable selection.

Features

- Gel-Filled Tubes are reverse-oscillated to allow slack for mid-span access – up to 288 fibers in cable
 - Gel-Free Buffer Tube options available – up to 216 fibers
- Pole-to-pole span lengths up to 1100 feet
- Single jacket design decreases the diameter and weight when compared to double jacket ADSS cable; thus reducing pole loading
- No separation requirement of ADSS from conductors per National Electric Safety Code (NESC) section 235

Applications

- Electric utility distribution power lines
 - Framed in supply or communications space
- Underground duct
- Enterprise OSP networks
- Fiber-to-the-X networks

Cable Components (Representative)

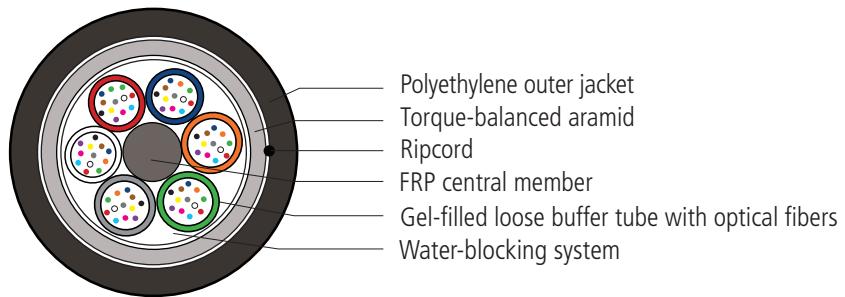

Optical Information

FIBER TYPE	MAXIMUM ATTENUATION (dB/km)				OVERFILL LAUNCH MIN. BANDWIDTH (MHz•km)		GIGABIT ETHERNET MINIMUM LINK DISTANCE (meters)	
	850 nm	1300 nm	1310 nm	1550 nm	850 nm	1300 nm	850 nm	1300 nm
(9) Single-mode	N/A	N/A	0.35	0.25	N/A	N/A	N/A	5000
(6) 62.5/125 GIGA-Link™ 300	3.5	1.2	N/A	N/A	200	600	300	550
(5) 50/125 GIGA-Link™ 600	2.9	0.9	N/A	N/A	500	500	600	600
(L) 50 Laser-Link™ 300	2.9	0.9	N/A	N/A	1500	500	900	550

Gigabit Ethernet Minimum Link Distances are based on "bandwidth"/modal dispersion constraints. Actual link distances may be constrained by attenuation, depending on specific loss budget.

continued
→



Flex-Span® ADSS Fiber Optic Cable

Reel Information

ITEM	REEL A		REEL B		REEL C		REEL D		REEL E	
	inches	cm	inches	cm	inches	cm	inches	cm	inches	cm
Reel Height	42	106.7	58	147.3	66	167.6	72	167.6	84	213.4
Reel Width Outside	36	91.4	38	96.5	42	106.7	42	106.7	40	101.6
Reel Width Inside	32	81.6	32	81.3	36	91.4	36	91.4	34	86.4
Drum Diameter	23	58.7	28	71.1	36	91.4	36	91.4	35	88.9
Arbor Hole Diameter	3	7.9	3	7.9	3	7.9	3	7.9	3	7.9
Reel Weight with Lagging	180 lbs	82 kg	420 lbs	191 kg	685 lbs	311 kg	710 lbs	311 kg	950 lbs	431 kg

AFL provides ADSS cable on several standard sizes of non-returnable wooden reels. Non-standard reel sizes are available upon request.

Typical Maximum Lengths

CABLE DIAMETER	REEL CAPACITY	
	feet	meters
< 0.85" (21.6 mm)	23,000	7,000

NOTE: Longer lengths may be available upon request.

Recommended Products for ADSS Fiber Optic Cable

DESCRIPTION	AFL NO.
Fiber Optic Cable Accessories	
ADSS Formed Wire Deadends	Refer to the ADSS Formed Wire Deadends spec sheet for specific AFL No.
ADSS Suspension Unit	Refer to the ADSS Suspension Unit spec sheet for specific AFL No.
ADSS Trunnion Assemblies	Refer to the ADSS Trunnion Assemblies spec sheet for specific AFL No.
ADSS Temporary Grip	Refer to the ADSS Temporary Grip spec sheet for specific AFL No.
AGC Downlead Clamp for ADSS	Refer to the AGC Downlead Clamp for ADSS spec sheet for specific AFL No.
AVD Series Spiral Vibration Dampers	Refer to the AVD Series Spiral Vibration Dampers spec sheet for specific AFL No.
Coil Brackets	Refer to the Coil Brackets spec sheet for specific AFL No.
For more ADSS Cable Accessories, go to the ADSS Fiber Optic Cable Hardware web page	
Fiber Optic Splice Closures	
Apex® X-2 Sealed Splice Closure	Refer to the Apex X-2 spec sheet for specific AFL No.
Apex® X-2S Sealed Splice Closure	Refer to the Apex X-2S spec sheet for specific AFL No.

Temperature Specifications

TEMPERATURE RANGE	
Operation	-40°C to +70°C
Storage	-50°C to +70°C
Installation	-30°C to +70°C

Qualifications

GOVERNING BODY	STANDARD CODE	COMPONENT
IEEE	1222	Cable
TIA	598-D	Fiber

Contact AFL for your customized ADSS solution.

continued
→



ADESDFW2-256 and 307



ADELD2E-323T and 383T



ADELD2E-424005TE
* shown with optional thimble eye

Mini-Dead Ends

The Mini-Dead Ends are designed for fast and easy installation of your ADSS Mini-Span® cable. The Mini-Dead End is ideal in crowded distribution environments where its shorter length allows for efficient installation. This unique low-cost product is used in typical spans with 1%-2% installation sag.

Features

- Easy and quick installation
- No special tools or hardware required for installation
- Small, requiring less storage space

Ordering Information

APPLICATION & DESCRIPTION	AFL NO.
Aerial Drop 256 150 ft NESC heavy, 275 ft NESC medium, 550 ft NESC light	ADESDFW2-256
Aerial Drop 307—Short Span (250 lb max. tension) 65 ft NESC heavy, 115 ft NESC medium, 210 ft NESC light	ADESDFW2-307
Aerial Drop 307—Long Span 220 ft NESC heavy, 400 ft NESC medium, 675 ft NESC light	ADELD2E-013TE
ADSS Mini-Span 323 175 ft NESC heavy, 300 ft NESC medium, 500 ft NESC light	ADELD2E-323T
ADSS Mini-Span 383 180 ft NESC heavy, 300 ft NESC medium, 450 ft NESC light	ADELD2E-383T
ADSS Mini-Span 424 275 ft NESC heavy, 450 ft NESC medium, 600 ft NESC light	ADELD2E-424005

NOTE: Part numbers ADEW10J1-AL535, and ADEW16J1-AL693 attach to structure via common pole hardware sold separately such as thimble eye, ram's head, guy hooks, etc.

For spans greater than the span lengths above, contact Customer Service.

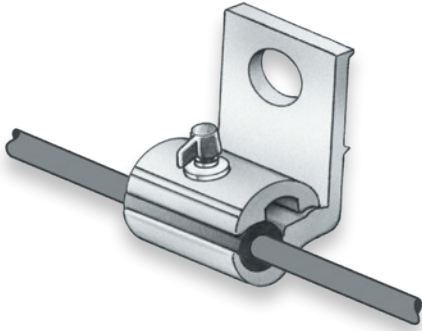

Mini-Bracket

Mini-Bracket

Mini Brackets are used for short and medium spans of ADSS fiber optic cable as well as Aerial Drop cables. Mini Brackets are sized to fit specific ADSS diameters. Standard Mini Brackets are employed with fitted bushings to provide a good support/groove fit and to prevent the support from damaging the cable. The bolted supports are supplied with aluminum captive bolts to simplify installation with no loose parts.

Features

- Maximum one side angle: 8.5 degrees
- Estimated weight: 2.9 lbs. (1.3 Kg)
- Maximum rated strength: 3,000 lbs.
- Hand tighten bolt to 25 in. lbs. (2.8 N-m)
- Slip load at 4 to 6% of RBS

Ordering Information

DESCRIPTION	AFL NO.
Aerial Drop 256 maximum line angle = 17° (150 ft NESC heavy, 275 ft NESC medium, 550 ft NESC light)	AMBB256
Aerial Drop 307 maximum line angle = 17° (220 ft NESC heavy, 400 ft NESC medium, 675 ft NESC light)	AMBB307
ADSS Mini-Span 424 maximum line angle = 17° (275 ft NESC heavy, 450 ft NESC medium, 600 ft NESC light)	AMBB424
ADSS Mini-Span 484 maximum line angle = 17° (275 ft NESC heavy, 400 ft NESC medium, 525 ft NESC light)	AMBB484-535
ADSS Mini-Span 535 maximum line angle = 17° (350 ft NESC heavy, 550 ft NESC medium, 675 ft NESC light)	AMBB484-535

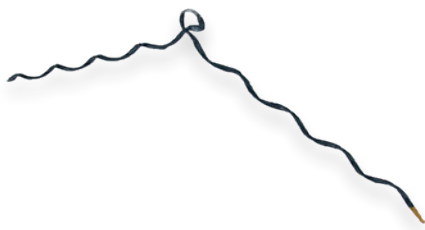

ATS 321/330
ATS 371/383

Mini Formed Wire Tangent Support (FTS)

Formed Wire Tangent Supports (FTS) are used with ADSS Mini-Span® 323 and Mini-Span® 383 for short span applications. Tangent supports provide a method of attaching AFL's smallest ADSS Mini-Span designs with excellent unbalanced load capability and bend relief support. This product is designed to connect directly to J-hooks on wood poles for an economical solution.

Ordering Information

DESCRIPTION	AFL NO.
ADSS Mini-Span 323 maximum line angle = 20°(175 ft NESC heavy, 300 ft NESC medium, 500 ft NESC light)	ATS321/330
ADSS Mini-Span 383 maximum line angle = 20°(180 ft NESC heavy, 300 ft NESC medium, 450 ft NESC light)	ATS371/383

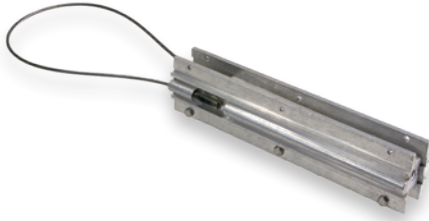

ADEW10J1-AL535

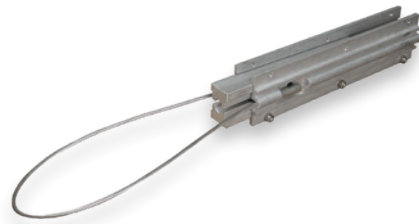

ADEW16J1-AL693

Wedge Dead End

(to be used only on Standard ADSS Cable up to 0.890" diameter, 144 fibers)

AFL offers wedge dead ends that ease and speed ADSS cable installation. The ADSS Wedge Dead End is ideal in crowded distribution environments because its shorter length allows for safer and efficient installation. The Wedge Dead End comes with all parts assembled. The side plates are properly aligned with spacers and self-locking hex bolts, as well as retainers. Lubricated wedges are pre-installed inside the body of the dead end.

Caution: The load ratings shown here are based on performance results of certain cable configurations and may not be representative of all manufacturers' ADSS cable designs. AFL strongly recommends that before using this product, you contact AFL to obtain the recommended load rating and to verify that the wedge dead end has been qualified for use with the proposed cable. AFL will perform a qualification test at no charge.

Specifications

PARAMETER	VALUE
Wedge Length	10" or 16" depending on cable characteristics
Cable O.D.	0.512" to 0.890" (13 mm to 22.6 mm)
Hold Strength	100% of Maximum Rated Cable Load (MRCL)
Maximum Attenuation Change	0.05 dB at 100% MRCL

Benefits

- Wedge-type design is safer than spiral wrap style dead ends
- Fewer parts, smaller and easier to store
- Attaches to structure via common pole hardware sold separately (thimble eye, ram's head, etc.)

Features

- Easier and faster installation
- Lower total system costs
- No special tools or hardware required for installation

APPLICATION & DESCRIPTION	AFL NO.
ADSS Mini-Span® 535 500 ft NESC heavy, 700 ft NESC medium, 875 ft NESC light Maximum loading capability is 1500 lbs.	ADEW10J1-AL535
ADSS Mini-Span 693 500 ft NESC heavy, 600 ft NESC medium, 750 ft NESC light Maximum loading capability is 1500 lbs.	ADEW16J1-AL693

Ordering Information for Double Jacket Cables

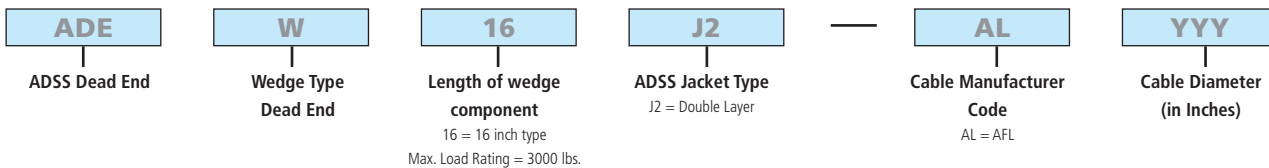

Application Notes:

1. For use with ADSS cables with polyethylene jackets in low voltage environments only. Not for use in high voltage environments where tracking resistant cables are required.
2. AFL fiber optic cable and related hardware are designed to work as a system. Dead ends may not be available for cable from other manufacturers.

Limited Tension Formed Wire Dead End for ADSS Cable

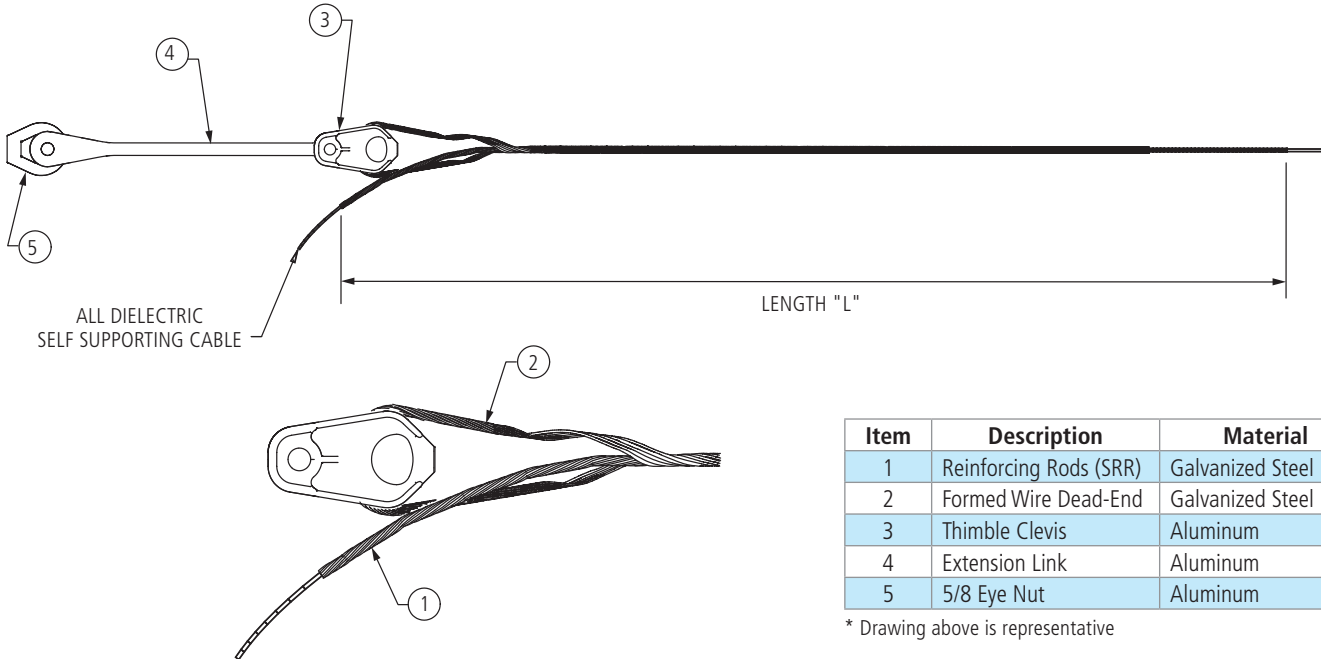

Item	Description	Material
1	Reinforcing Rods (SRR)	Galvanized Steel
2	Formed Wire Dead-End	Galvanized Steel
3	Thimble Clevis	Aluminum
4	Extension Link	Aluminum
5	5/8 Eye Nut	Aluminum

* Drawing above is representative

Features

- Components strength—6,500 lbs.
- Maximum initial tension—up to 1,000 lbs.
- Maximum loaded tension—up to 2,500 lbs.
- Dead end component may be reused once during initial installation
- Contact AFL for track-resistant ADSS application

Ordering Information

AFL NO.	CABLE OD (IN)	LENGTH "L" (IN)	COLOR CODE
ADESE380/400C	0.380 - 0.400	48	Red
ADESE400/424C	0.400 - 0.424	48	Black
ADESE425/451C	0.425 - 0.451	48	Yellow
ADESE452/481C	0.452 - 0.481	48	Green
ADESE482/510C	0.482 - 0.510	48	Orange
ADESE511/542C	0.511 - 0.542	48	Blue
ADESE543/577C	0.543 - 0.577	48	White
ADESE578/613C	0.578 - 0.613	48	Red
ADESE614/651C	0.614 - 0.651	48	Black
ADESE652/692C	0.652 - 0.692	48	Yellow
ADESE693/737C	0.693 - 0.737	48	Green
ADESE738/784C	0.738 - 0.784	48	Orange
ADESE785/834C	0.785 - 0.834	48	Blue
ADESE835/889C	0.835 - 0.889	48	White
ADESE890/945C	0.890 - 0.945	48	Red
ADESE946/1007C	0.946 - 1.007	48	Black
ADESE1008/1073C	1.008 - 1.073	60	Yellow
ADESE1074/1140C	1.074 - 1.140	60	Green
ADESE1141/1212C	1.141 - 1.212	60	Orange
ADESE1213/1288C	1.213 - 1.288	60	Blue

Medium Tension Dead End for ADSS Cable

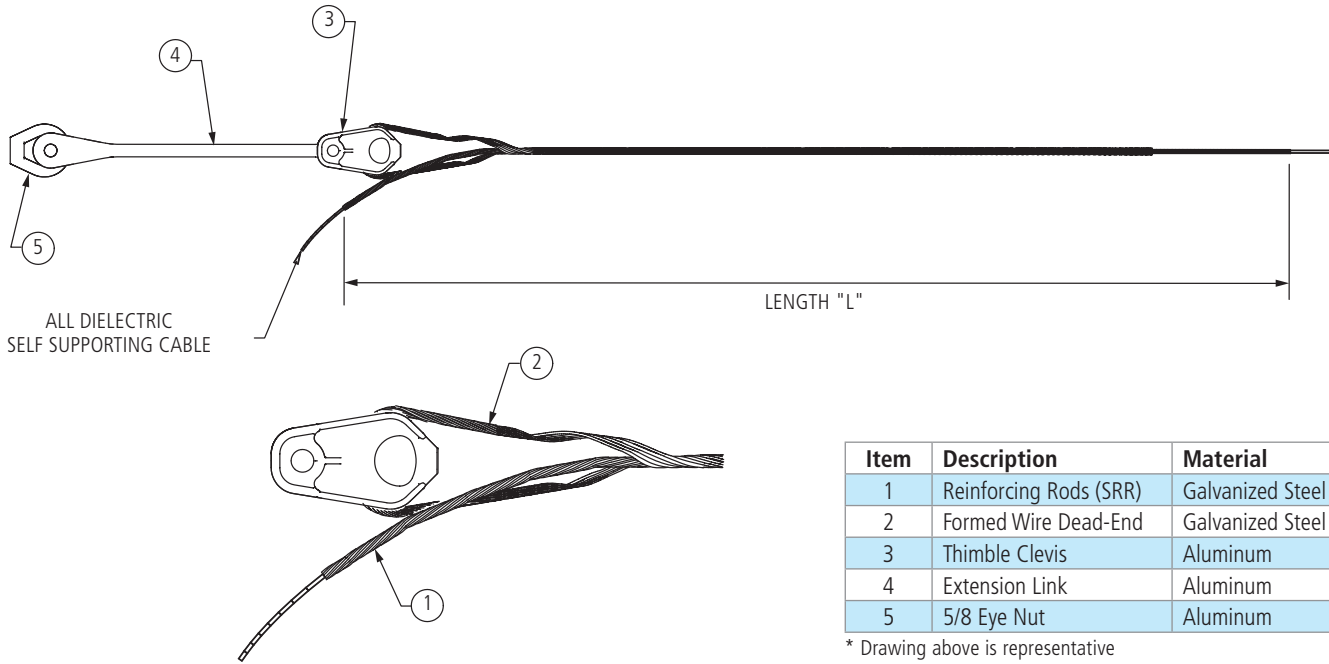

Features

- Component strength—6,500 lbs.
- Maximum initial tension—up to 2,000 lbs.
- Maximum loaded tension—up to 4,000 lbs.
- Dead end component may be reused once during initial installation
- Contact AFL for track-resistant ADSS application

Ordering Information

AFL NO.	CABLE OD (IN)	LENGTH "L" (IN)	COLOR CODE
ADEME482/510C	.482-.510	72	Orange
ADEME511/542C	.511-.542	73	Blue
ADEME543/577C	.543-.577	74	White
ADEME578/613C	.578-.613	78	Red
ADEME614/651C	.614-.651	80	Black
ADEME652/692C	.652-.692	80	Yellow
ADEME693/737C	.693-.737	82	Green
ADEME738/784C	.738-.784	88	Orange
ADEME785/834C	.785-.834	92	Blue
ADEME835/889C	.835-.889	94	White
ADEME890/945C	.890-.945	96	Red
ADEME946/1007C	.946-1.007	98	Black
ADEME1008/1073C	1.008-1.073	102	Purple
ADEME1074/1140C	1.074-1.140	102	Pink
ADEME1141/1212C	1.141-1.212	104	Brown
ADEME1213/1288C	1.213-1.288	107	Orange

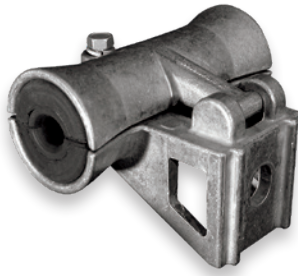

Single Trunnion Cable Support



Double Trunnion Cable Support (closed)



Double Trunnion Cable Support (open)

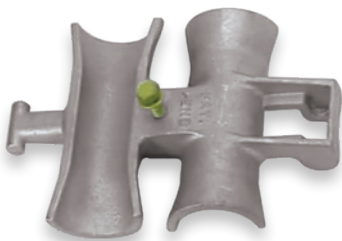

Conversion Kit

Trunnion Assemblies— Single and Double Cables

AFL offers trunnions with various mounting capabilities: bolted, banded or standoff. Trunnions reduce installation costs by functioning as a pull-through during installation (maximum line angle for stringing is 15° total, 7.5° per side, number of structures not to exceed 30). No block or pulley is needed provided these conditions are met.

Features

- May be used as a pull-through by removing the bushing inserts
- Double cable supports option
- High-strength aluminum
- Smaller and more compact design
- Facilitates faster installation
- Color-coded range taking inserts for easy identification
- Versatile mounting styles to fit different structure types: bolted, banded or standoff
- Banding and pole hardware supplied by customer
- Lowers the total cost of installation
- Span Length: 600 ft.—NESC Heavy
1,200 ft.—NESC Light

Ordering Information—Single Cable Support

AFL NO.	CABLE O.D. RANGE		ESTIMATED WEIGHT		BUSHING COLOR CODE
	INCHES	MILLIMETERS	LBS	KG	
ATGN325/375	0.325" - 0.375"	8.26 - 9.53	2.06	.934	Green + White
ATGN376/419	0.376" - 0.419"	9.55 - 10.64	2.06	.934	Orange + White
ATGN420/474	0.420" - 0.474"	10.67 - 12.05	2.05	.930	Purple + White
ATGN475/525	0.475" - 0.525"	12.07 - 13.34	2.05	.930	Blue
ATGN526/575	0.526" - 0.575"	13.36 - 14.61	2.05	.930	Orange
ATGN576/625	0.576" - 0.625"	14.63 - 15.88	2.04	.925	Brown
ATGN626/675	0.626" - 0.675"	15.90 - 17.15	2.04	.925	Green
ATGN676/725	0.676" - 0.725"	17.17 - 18.42	2.03	.921	White
ATGN726/775	0.726" - 0.775"	18.44 - 19.69	2.03	.921	Red
ATGN776/825	0.776" - 0.825"	19.71 - 20.96	2.02	.916	Purple
ATGN826/875	0.826" - 0.875"	20.98 - 22.23	2.02	.916	Yellow
ATGN876/925	0.876" - 0.925"	22.25 - 23.50	2.02	.916	Pink
ATGN926/959	0.926" - 0.959"	23.52 - 24.36	2.02	.916	Blue + White
ATGN960/1045	0.960" - 1.045"	24.38 - 26.54	2.02	.916	Gray

Application Notes:

1. For use with ADSS cables with polyethylene jackets in low voltage environments only. Not for use in high voltage environments where tracking resistant cables are required.
2. As a stringing block:
Maximum line angle = 15° (7.5° per side)
Maximum number of structures = 30
3. For final installation:
Maximum line angle = 22° (11° per side)

continued
→

Trunnion Assemblies (cont.)

Ordering Information—Double Tangent Support

BUSHING NUMBER		CABLE O.D. RANGE		BUSHING COLOR CODE	MAXIMUM SPAN CAPABILITIES USING NESC LOADS IN FEET/METERS	ESTIMATED WEIGHT	
"A"	"B"	INCHES	MM			HEAVY	LBS
325	325	.325-.375	8.26-9.53	Green + White	600/182.9	4.00	1.814
376	376	.376-.419	9.55-10.64	Orange + White	600/182.9	4.00	1.814
420	420	.420-.474	10.67-12.04	Purple + White	600/182.9	3.99	1.810
475	475	.475-.525	12.07-13.34	Blue	600/182.9	3.99	1.810
526	526	.526-.575	13.36-14.61	Orange	600/182.9	3.99	1.810
576	576	.576-.625	14.63-15.88	Brown	600/182.9	3.98	1.805
626	626	.626-.675	15.90-17.15	Green	600/182.9	3.98	1.805
676	676	.676-.725	17.17-18.42	White	600/182.9	3.97	1.801
726	726	.726-.775	18.44-19.69	Red	600/182.9	3.97	1.801
776	776	.776-.825	19.71-20.96	Purple	600/182.9	3.96	1.796
826	826	.826-.875	20.98-22.23	Yellow	600/182.9	3.96	1.796
876	876	.876-.925	22.25-23.50	Pink	500/152.4	3.96	1.796
926	926	.926-.959	23.52-24.36	Blue + White	CONTACT AFL	3.96	1.796
960	960	.960-1.045	24.38-26.54	Gray	CONTACT AFL	3.96	1.796

How to Order

Order by assembling part number as shown:

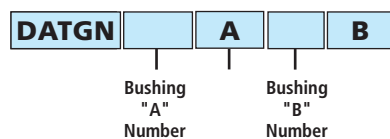

- Reference table above. See Note 1 below.
- Example:
 - First cable 0.500" OD → Bushing "A" number = 475
 - Second cable 0.750" OD → Bushing "B" number = 726
 - Order by part number: **DATGN475A726B**

Notes:

1. Bushing "A" and "B" may be the same or different.
2. Attachment hardware or stainless steel banding to be supplied by customer.
3. To order Conversion Kits, use part number DATGNDCBWH.

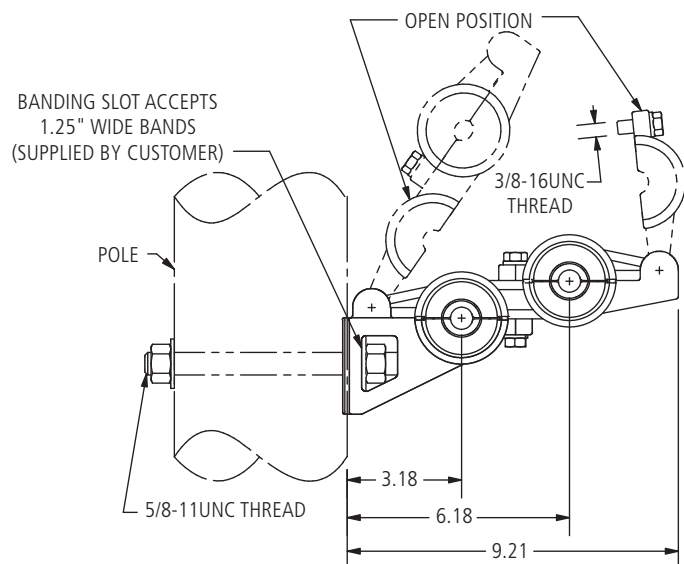

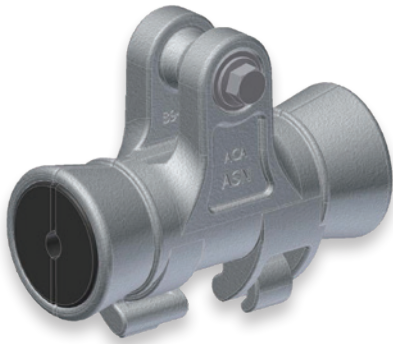

Correct orientation of bushing shown above.

Application Note:

1. For use with ADSS cables with polyethylene jackets in low voltage environments only. Not for use in high voltage environments where tracking resistant cables are required.

ADSS Suspension Unit

AFL's ADSS suspension unit is used to provide long term performance for spans up to 1200 feet (see span rating below). The interlocking halves of the aluminum body clamp provides positive alignment and utilize our proven EDPM bushings to gently grip the cable. The 3/8" mounting bolt is held captive by an o-ring. This product cannot be used as a stringing device.

Specifications

PARAMETER	VALUE
Span Length Rating	600 feet (200 meters) NESC Heavy 900 feet (274 meters) NESC Medium 1200 feet (365 meters) NESC Light
Vertical Load Rating	5000 lbs
Torque Requirement	Mounting bolt should be tightened to 25 ft-lb
Mounting Hardware	5/8" oval eye nut and anchor shackle (both parts not shown) can be included in the assembly by adding the suffix "AS01" to the part number
Line Angle	Max line angle is 30 degrees
Cable Types Recommended	For use on standard polyethylene jackets only DO NOT USE on track resistant cables
Slip Strength	Contact AFL for specific slip strength requirements

Ordering Information

AFL NO.	CABLE RANGE		WEIGHT		BUSHING COLOR CODE
	INCHES	MM	LBS	KG	
ASN325/375	0.325-0.375	8.3-9.5	2.2	1.0	Green + White
ASN376/419	0.376-0.419	9.6-10.6			Orange + White
ASN420/474	0.420 - 0.474	10.7 - 12.0			Purple + White
ASN475/525	0.475 - 0.525	12.1 - 13.3			Blue
ASN526/575	0.526 - 0.575	13.4 - 14.6			Orange
ASN576/625	0.576 - 0.625	14.6 - 15.9			Brown
ASN626/675	0.626 - 0.675	15.9 - 17.1			Green
ASN676/725	0.676 - 0.725	17.2 - 18.4			White
ASN726/775	0.726 - 0.775	18.4 - 19.7			Red
ASN776/825	0.776 - 0.825	19.7 - 21.0			Purple
ASN826/875	0.826 - 0.875	21.0 - 22.2			Yellow
ASN876/925	0.876 - 0.925	22.3 - 23.5			Pink
ASN926/959	0.926 - 0.959	23.5 - 24.4			—
ASN960/1045	0.960 - 0.1045	24.4 - 26.5			Gray

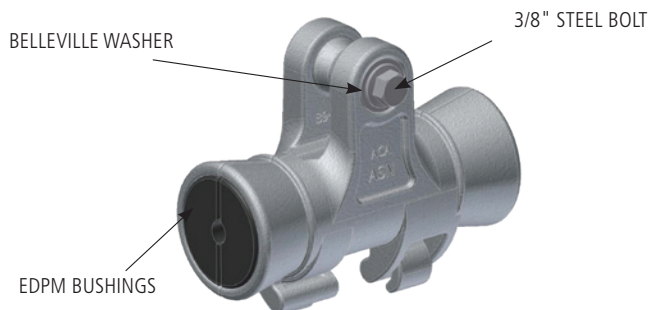

Formed Wire Suspension for ADSS Cable

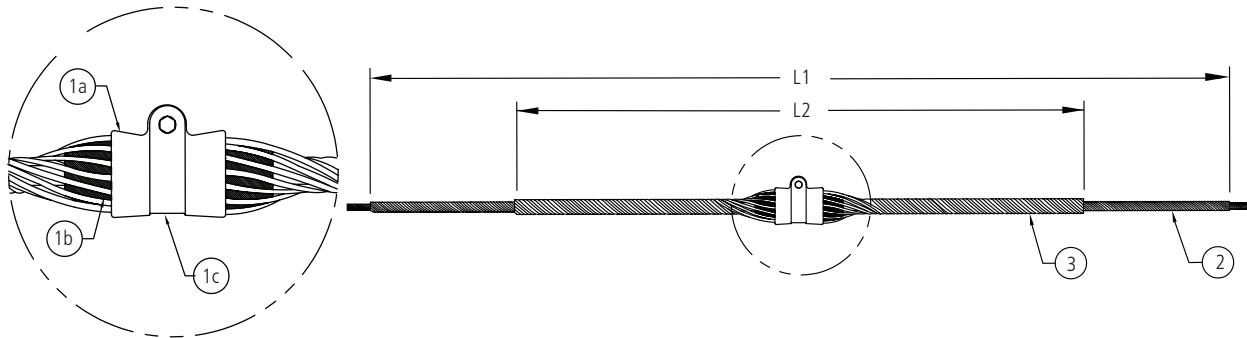

Features

- For line or elevation angle changes less than 30°
- Max vertical load—20,000 lbs.

Item	Description	Material
1a,c	Suspension Housing	Aluminum Alloy
1b	Insert (2 Halves)	Elastomer
2	Reinforcing Rods (SRR)	Aluminum Alloy
3	Outer Support Rods	Aluminum Alloy

Ordering Information

CABLE O.D. RANGE	STRUCTURAL REINFORCEMENT RODS				OUTER RODS				AFL NO.
	LENGTH "L1" (INCHES)	ROD DIA. (INCHES)	RODS PER SET	COLOR CODE	LENGTH "L2" (INCHES)	ROD DIA. (INCHES)	RODS PER SET	COLOR CODE	
0.399" - 0.418"	80	.146	10	Yellow	42	.204	11	Yellow	ASU399/418
0.419" - 0.439"	80	.146	10	Black	42	.204	11	Black	ASU419/439
0.440" - 0.458"	81	.146	11	White	43	.204	11	White	ASU440/458
0.459" - 0.461"	84	.167	10	Purple	46	.250	10	Orange	ASU459/461
0.462" - 0.476"	84	.167	10	Purple	46	.250	10	Purple	ASU462/476
0.477" - 0.503"	84	.146	12	Orange	46	.250	10	Orange	ASU477/503
0.504" - 0.511"	84	.146	12	Red	46	.250	10	Purple	ASU504/511
0.512" - 0.536"	87	.167	11	Blue	49	.250	11	Blue	ASU512/536
0.537" - 0.559"	87	.167	11	Green	49	.250	11	Green	ASU537/559
0.560" - 0.565"	87	.167	11	Green	49	.250	11	Green	ASU560/565
0.566" - 0.573"	92	.182	11	Black	54	.250	12	Black	ASU566/573
0.574" - 0.598"	92	.182	11	Black	54	.250	12	White	ASU574/598
0.599" - 0.625"	92	.182	12	Brown	54	.310	12	Brown	ASU599/625
0.626" - 0.632"	102	.204	11	Red	63	.310	11	Red	ASU626/632
0.633" - 0.666"	102	.204	11	Red	63	.310	11	Blue	ASU633/666
0.667" - 0.682"	102	.204	12	Yellow	63	.310	11	Green	ASU667/682
0.683" - 0.710"	102	.204	12	Yellow	63	.310	11	Yellow	ASU683/710
0.711" - 0.728"	102	.204	12	White	63	.310	12	Black	ASU711/728
0.729" - 0.744"	102	.204	12	White	63	.310	12	White	ASU729/744
0.745" - 0.750"	102	.204	12	White	63	.310	12	White	ASU745/750
0.751" - 0.786"	102	.204	13	White	63	.310	12	Brown	ASU751/786
0.787" - 0.814"	111	.250	11	Green	72	.365	11	Green	ASU787/814
0.815" - 0.845"	111	.250	12	Yellow	72	.365	11	Yellow	ASU815/845
0.846" - 0.855"	111	.250	12	Green	72	.365	12	Blue	ASU846/855
0.856" - 0.894"	119	.250	12	Black	80	.365	12	Black	ASU856/894
0.895" - 0.907"	119	.250	12	White	80	.365	12	White	ASU895/907
0.908" - 0.916"	119	.250	13	Purple	80	.365	12	Purple	ASU908/916
0.917" - 0.929"	119	.250	13	Brown	80	.365	12	Brown	ASU917/929
0.930" - 0.942"	119	.250	13	Red	80	.365	12	Red	ASU930/942
0.943" - 0.977"	119	.250	13	Orange	80	.365	13	Orange	ASU943/977



AGC Series ADSS Downlead Clamp with galvanized steel hardware

AGC Series ADSS Downlead Clamp

AFL's AGC Series Downlead Clamps are used to guide ADSS Fiber Optic Cable from the top of the structure to the splice location. Our clamps install easily and provide proper spacing and hold strength without damage to the cable. From poles to towers, we offer a full line of ADSS Downlead Clamps to meet the needs of any application.

Features

- Compressive elastomer material protects cable jacket
- Galvanized lag screw, square curved washer and standard round washers included

Ordering Information

AFL NO.	GROOVE CODE	CABLE DIAMETER (INCHES)		DIMENSIONS (INCHES)
		MIN.	MAX.	A
AGC468468D	468	0.375	0.468	2.75
AGC562562D	562	0.469	0.562	2.75
AGC656656D	656	0.563	0.656	2.75
AGC750750D	750	0.657	0.750	2.75
AGC849849D	849	0.751	0.849	3.00
AGC948948D	948	0.850	0.948	3.00
AGC105105D	105	0.949	1.050	3.00

Note: Alternative configurations are available. Please contact AFL for additional information.

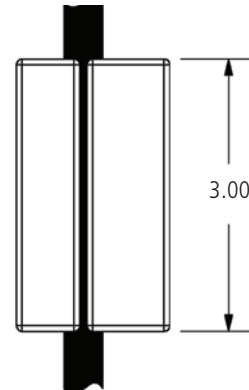
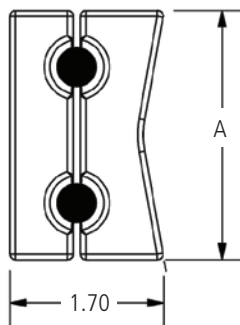
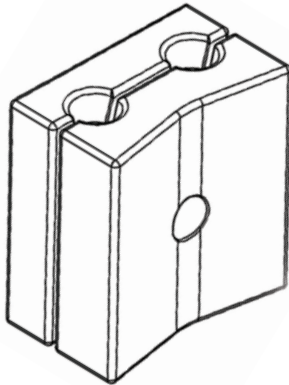

INSTALLATION INSTRUCTIONS
FDOA B & C Series – Downlead Clamp for OPGW and ADSS
with Optional Lattice Structure Adapter

Fiber Optic Cable Hardware

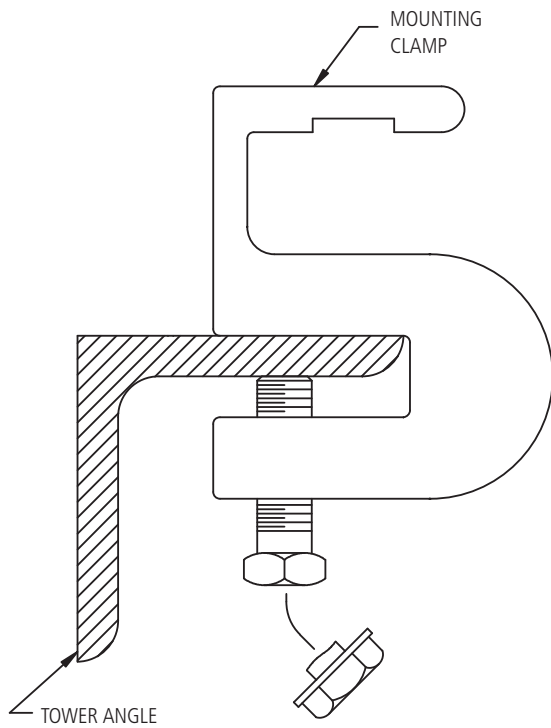

FIG. 1

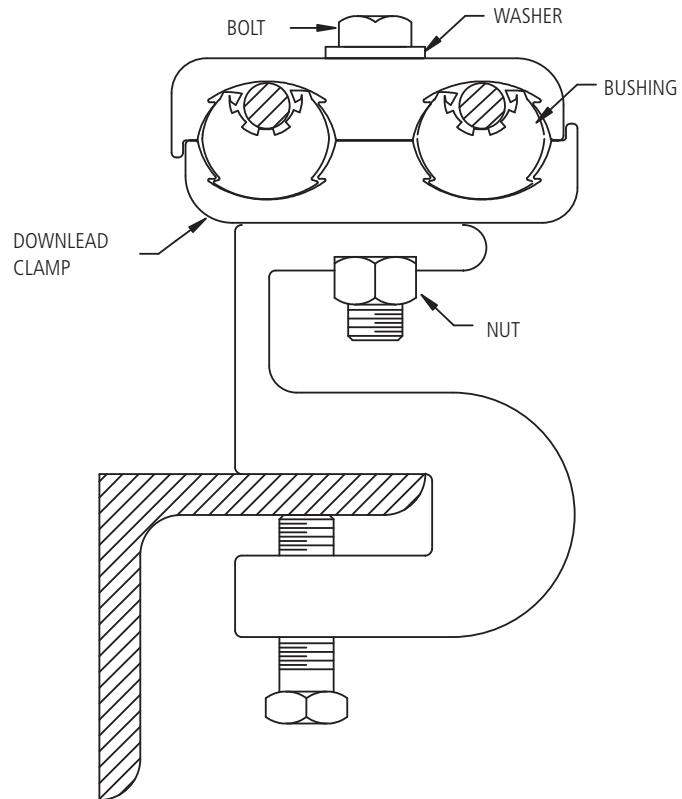

FIG. 2

1. Attach mounting clamp adapter to tower angle (as illustrated in **Fig. 1**) with break-away bolt (breaking torque range: 20-25 lbf-ft).
2. Lay the proper OPGW and/or ADSS cable in each bushing groove of the bottom clamp. Place top clamp over the cables and ensure the bushing color code and cable diameter match the table below.
3. Bolt the downlead clamp to mounting clamp (as illustrated in **Fig. 2**). Hold the mounting clamp and downlead clamp halves while tightening the hardware to prevent rotation and bending of the OPGW and/or ADSS cables.
4. Tighten the bolt on the downlead clamp until a bolt torque of 20-25 lbf-ft is achieved.

COLOR	RED-B4	GREEN-B5	YELLOW-B6	BLUE-B7	WHITE-B8	BLACK-B9	B10
RANGE	.400 - .500	.501 - .600	.601 - .700	.701 - .800	.801 - .900	.900 - 1.00	1.001 - 1.100

CAUTION: In order to avoid any damage to the OPGW and/or ADSS cable, it is essential that the cable be clamped only in the recommended bushings.

AVD Series Spiral Vibration Dampers

AFL's AVD Series Spiral Vibration Dampers are designed to eliminate the damage caused by Aeolian vibration and reduce overall vibration on bare All-Dielectric Self-Supporting (ADSS) cables. Made of weather-resistant, non-corrosive plastic, these dampers have a large, helically-formed damping section sized for the ADSS cable. A smaller gripping section gently grips the ADSS cable. Each damper is marked with the conductor range and color coded to indicate the cable diameter size range.

Line design, temperature, tension, wind flow exposure and history of vibration on similar construction in the location are factors to consider when determining the amount of protection required. Installation can be on both sides of the support location—at least one hand-width from the ends of Armor Rods or cable hardware. Depending on the customer's specific conditions, AFL recommends the AVD Spiral Vibration Damper for ADSS cable in accordance with the recommended application chart.

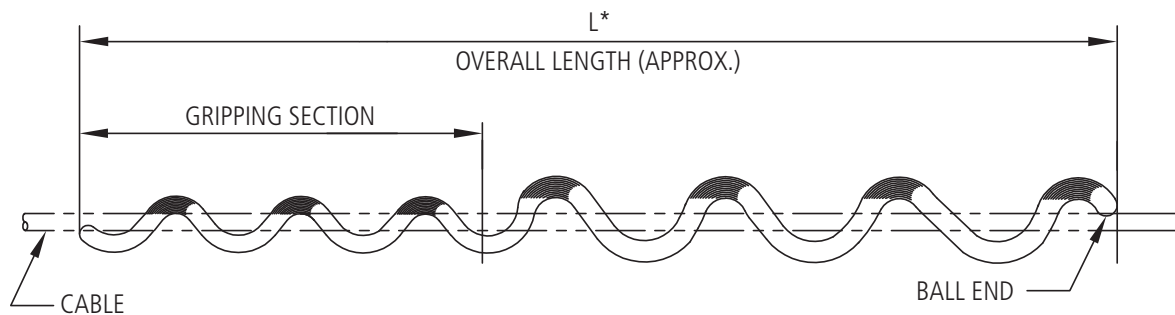
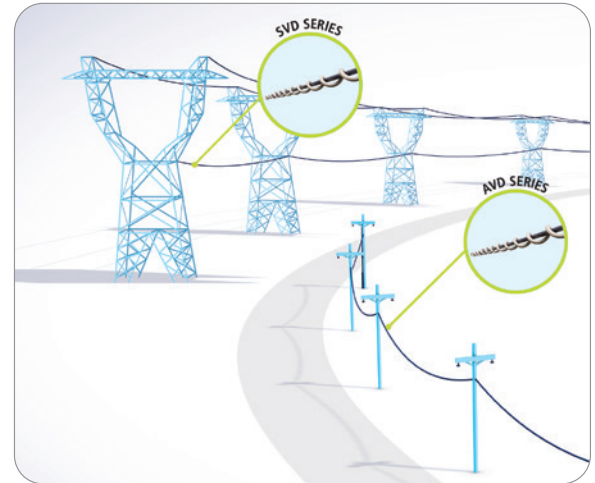

* For "L" dimensions, see table below.

Ordering Information

Select catalog number based on cable diameter. Example: for 0.512" diameter, order AVD462/563

Conductor Diameter Cross Reference

AFL NO.	PLP NO.	CONDUCTOR DIAMETER RANGE inches (mm)	"L" ROD LENGTH inches (mm)	WEIGHT lbs (KG)	STANDARD PACK
AVD250/326	50502393	0.250-0.326 (6.35-8.29)	49 (1244)	27 (12.247)	50
AVD327/461	50502272	0.327-0.461 (8.30-11.72)	51 (1295)	30 (12.701)	50
AVD462/563	50502274	0.462-0.563 (1.73-14.32)	53 (1346)	30 (13.608)	50
AVD564/770	50509862	0.564-0.770 (14.33-19.30)	64 (1625)	47 (21.319)	25
AVD771/876	50503057	0.771-0.876 (19.58-22.25)	71 (1803)	29 (13.154)	25
AVD877/1000	50503576	0.877-1.000 (22.26-25.40)	75 (1905)	36 (16.329)	25
AVD1001/1250	50503909	1.001-1.250 (25.41-31.75)	90 (2286)	41 (18.597)	25

continued
→

AVD Series Spiral Vibration Dampers (cont.)

Damper Recommendations for Placement

Damper Recommendation applies for specified AFL dampers only. If alternative type or different manufacturer dampers are applied instead, it is possible that damage will occur on the conductor and/or the accessories.

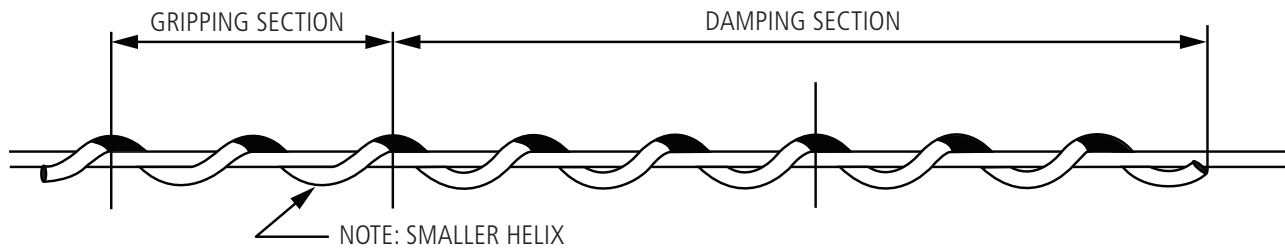

SPAN LENGTH	INITIAL TENSION PERCENTAGE OF CABLE RATED BREAKING STRENGTH (RBS) AT NOMINAL TEMPERATURE 60°F				
	0-10%	11-15%	16-20%	21-25%	>25%
< 250 ft.	0	2/s	2/s	2/s	2/s
251-500	2/s	2/s	2/s	2/s	4/s
501-800	2/s	2/s	2/s	4/s	4/s
801-1600	4/s	4/s	4/s	6/s	6/s
1601-2400	6/s	6/s	6/s	8/s	8/s
2401-3000	8/s	8/s	8/s	10/s	10/s
3001-3500	10/s	10/s	10/s	12/s	12/s
3501-4000	12/s	12/s	12/s	16/s	16/s
4001-4500	16/s	16/s	16/s	16/s	18/s
4501-5000	18/s	18/s	18/s	18/s	20/s

Symbol Designation

- 2/s = 2 dampers per span, 1 on each end of the span
- 4/s = 2 dampers in tandem on each end of the span
- 6/s = 3 dampers in tandem on each end of the span
- 8/s = 3 dampers in tandem + 1 damper on each end of the span
- 10/s = 3 dampers in tandem + 2 dampers in tandem on each end of the span
- 12/s = 3 dampers in tandem + 3 dampers in tandem on each end of the span
- 16/s = 3 dampers in tandem + 3 dampers in tandem + 2 dampers in tandem on each end of the span
- 18/s = 3 dampers in tandem + 3 dampers in tandem + 3 dampers in tandem on each end of the span
- 20/s = 4 dampers in tandem + 3 dampers in tandem + 3 dampers in tandem on each end of the span

Placement and Spacing

1. AVD shall be placed approximately 5 inches away from any line hardware (suspension, deadend, armor rods, other SVDs, etc.).
2. AVDs can be nested in tandem for up to three units to prevent the units from interfering with each other.
3. AVDs shall be applied to bare cable only to ensure proper performance.



Fiber Storage Units for ADSS Fiber Optic Cable

AFL Fiber Storage Units (FSU) are used to conveniently store an extra length of cable along the ADSS cable run for later use. Furnished as pairs (kit contains two Fiber Storage Units and two sets of hanger brackets), these FSUs are constructed from UV stabilized PPE thermoplastic. All basic hardware for attachment to the ADSS cable is provided. ADSS cable mount support brackets meet Telcordia® specifications. Epoxy coated clamping devices meet ASTM specifications A153 and B695.

Features

- Small profile and side facing channel minimizes ice and leaf loading
- Constructed from UV stabilized PPE thermoplastic
- Basic hanging hardware (bolts, nuts, washers) and strand clamps all included
- Tie-wrap slots for securing cable
- Epoxy-coated strand clamps

The mounting bracket features an angled, tent-profile, epoxy-coated bracket for standard ADSS cable mounting.

Specifications

PARAMETER	FOSP-ADSS-12	FOSP-ADSS-17
Nominal Channel Width - in. (cm)	0.625	1.00
Minimum Bend Diameter - in. (cm)	12	17.5

Ordering Information

DESCRIPTION	FOSP-ADSS-12	FOSP-ADSS-17
FOS ADSS Kit	FA000049	FA000050

Kits contain one pair of FOSP and two sets of hanger brackets.

Qualifications

GOVERNING BODY	STANDARD CODE
ASTM	ASTM A153, ASTM B695

Typical Installation Diagram

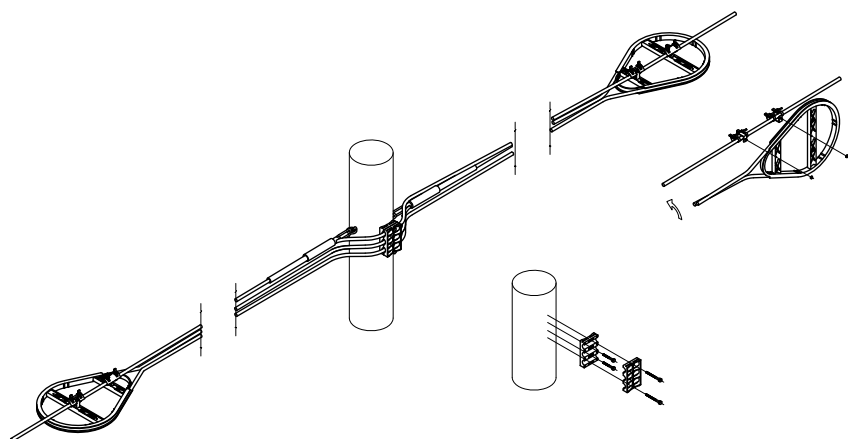

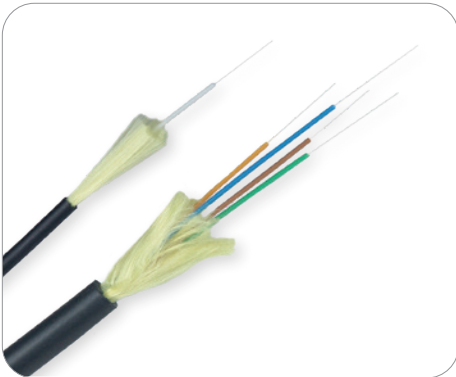

Tactical Tight Buffered Cable

AFL Tactical Tight Buffered Cables are ideal for use in installations where extreme environmental conditions are present. Designed to be deployed and retrieved in the field, AFL's Tactical Tight Buffered Cables are highly resistant to damage caused by repeated impacts crushing forces, abrasion and extreme temperatures.

Features

- Cut resistant, fire retardant, LSZH polyurethane jacket
- Highly flexible construction allows for multiple deployments
- All aramid strength members
- Performance in wide temperature range
- UV, Fungus and water resistant
- High impact and crush resistance
- Durable in high traffic areas
- MIL-PRF-49291 qualified fiber available (-RH designation)

Applications

- Field deployment in abusive environments
- Temporary installation of critical communications lines where quick retrieval and re-use is necessary
- High Traffic areas
- Security and Sensing applications
- Broadcast deployments
- Installations in harsh environments

Cable Components

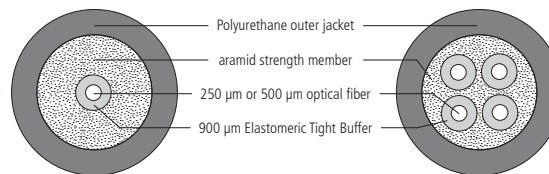

Specifications

CHARACTERISTIC	TEST PROCEDURE	PERFORMANCE
Tensile and elongation	EIA/TIA-455-33	
Operating tensile strength	EIA/TIA-455-33	
Low-temp flexibility	EIA/TIA-455-37	
Cyclic flexing	EIA/TIA-455-104	2000
Crush resistance	EIA/TIA-455-41	1800 N/cm or greater
Impact	EIA/TIA-455-25	200
Temperature cycling	EIA/TIA-455-3	-46°C to 85°C
Temperature/humidity cycling	EIA/TIA-455-5 Method B	
Life aging	EIA/TIA-455-4	
Freezing water immersion	EIA/TIA-455-98	



Tactical Tight Buffered Cable

Mechanical Data

AFL NO.	FIBER COUNT	NOMINAL DIAMETER		NOMINAL WEIGHT		MAXIMUM TENSILE LOAD		MINIMUM BEND RADIUS	
		INCHES	(MM)	LBS/1000FT	(KG/KM)	LBS (N)		INCHES (CM)	
						INSTALLATION	LONG TERM	INSTALLATION	LONG TERM
X5002*551#0H	2	0.22	(5.5)	16.2	(25)	400 (1780)	130 (578)	2.2 (5.5)	1.1 (2.8)
X5004*551#0H	4	0.22	(5.5)	16.2	(25)	400 (1780)	130 (578)	2.2 (5.5)	1.1 (2.8)
X5002*581#0H	2	0.23	(5.8)	21.5	(32)	400 (1780)	130 (578)	3.4 (8.7)	2.3 (5.8)
X5004*581#0H	4	0.23	(5.8)	21.5	(32)	400 (1780)	130 (578)	3.4 (8.7)	2.3 (5.8)
X5006*611#0H	6	0.24	(6.1)	22.2	(33)	400 (1780)	130 (578)	3.6 (9.2)	2.4 (6.1)
X5008*641#0H	8	0.25	(6.4)	28.8	(44)	470 (2090)	160 (712)	2.5 (6.4)	1.3 (3.2)
X5012*641#0H	12	0.25	(6.4)	30.8	(47)	470 (2090)	160 (712)	2.5 (6.4)	1.3 (3.2)

Note: Diameter and weight subject to change without notice

500 µm primary coated fiber available, replace H in AFL number with number corresponding below.

G = 500 µm Coated Optical Fiber

H = 250 µm Coated Optical Fiber

Replace asterisk (*) in AFL No. with corresponding fiber type below.

5 = 50/125 µm multimode GIGA-Link™ 600

6 = 62.5/125 µm multimode GIGA-Link™ 300

9 = Bend Insensitive G.657A1 single-mode

L = 50/125 µm OM3

C = 50/125 µm OM4

Replace hashtag (#) in AFL No. with jacket color. See Tactical Cable Ordering Guide.

Customer specified print available.

See Tactical Cable Ordering Guide AFL No. designations.

Qualifications

GOVERNING BODY	STANDARD CODE	COMPONENT
EIA/TIA	EIA/TIA-455-33, EIA/TIA-455-37, EIA/TIA-455-104, EIA/TIA-455-41, EIA/TIA-455-25, EIA/TIA-455-3, EIA/TIA-455-5 Method B, EIA/TIA-455-4, EIA/TIA-455-98	Fiber Optic Cable
U.S. Department of Defense	MIL-PRF-49291 MIL-PRF-85045	Optical Fiber Fiber Optic Cable

Temperature Specifications

TEMPERATURE RANGE	
INSTALLATION	-46°C to +85°C
OPERATION	-46°C to +85°C
STORAGE	-55°C to +85°C

Contact AFL for further details.



Please contact your AFL Sales Representative for information about our other products or services.

**FIBER OPTIC CABLE
(OPGW, ADSS, Loose Tube)**



**TEST AND INSPECTION
EQUIPMENT**



**FUSION SPLICING
SYSTEMS AND ACCESSORIES**



**FIELD-INSTALLABLE
CONNECTORS**

