

ADEW10J1-AL535

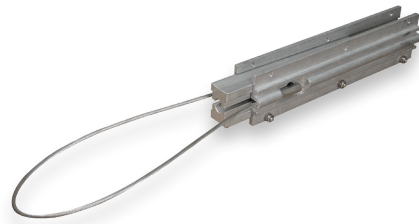

ADEW16J1-AL693

Wedge Dead End

(to be used only on Standard ADSS Cable up to 0.890" diameter, 144 fibers)

AFL offers wedge dead ends that ease and speed ADSS cable installation. The ADSS Wedge Dead End is ideal in crowded distribution environments because its shorter length allows for safer and efficient installation. The Wedge Dead End comes with all parts assembled. The side plates are properly aligned with spacers and self-locking hex bolts, as well as retainers. Lubricated wedges are pre-installed inside the body of the dead end.

Caution: The load ratings shown here are based on performance results of certain cable configurations and may not be representative of all manufacturers' ADSS cable designs. AFL strongly recommends that before using this product, you contact AFL to obtain the recommended load rating and to verify that the wedge dead end has been qualified for use with the proposed cable. AFL will perform a qualification test at no charge.

Specifications

PARAMETER	VALUE
Wedge Length	10" or 16" depending on cable characteristics
Cable O.D.	0.512" to 0.890" (13 mm to 22.6 mm)
Hold Strength	100% of Maximum Rated Cable Load (MRCL)
Maximum Attenuation Change	0.05 dB at 100% MRCL

Benefits

- Wedge-type design is safer than spiral wrap style dead ends
- Fewer parts, smaller and easier to store
- Attaches to structure via common pole hardware sold separately (thimble eye, ram's head, etc.)

Features

- Easier and faster installation
- Lower total system costs
- No special tools or hardware required for installation

APPLICATION & DESCRIPTION	AFL NO.
ADSS Mini-Span® 535 500 ft NESC heavy, 700 ft NESC medium, 875 ft NESC light Maximum loading capability is 1500 lbs.	ADEW10J1-AL535
ADSS Mini-Span 693 500 ft NESC heavy, 600 ft NESC medium, 750 ft NESC light Maximum loading capability is 1500 lbs.	ADEW16J1-AL693

Ordering Information for Double Jacket Cables

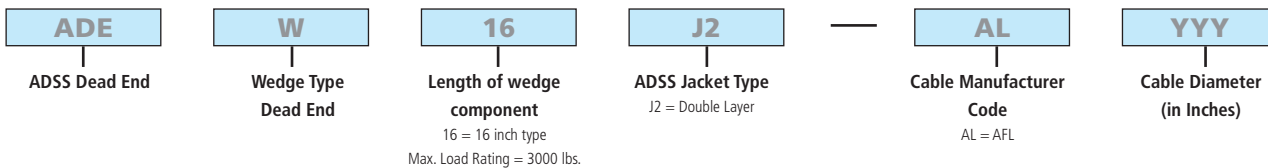

Application Notes:

1. For use with ADSS cables with polyethylene jackets in low voltage environments only. Not for use in high voltage environments where tracking resistant cables are required.
2. AFL fiber optic cable and related hardware are designed to work as a system. Dead ends may not be available for cable from other manufacturers.

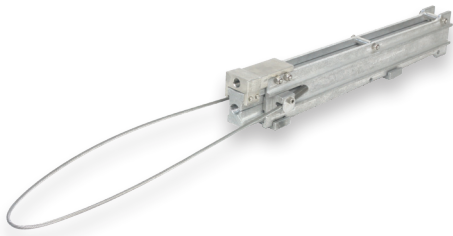

Temporary Grip

Temporary Grips are used in stringing the ADSS during sagging and where it is necessary to make short term catch on the ADSS.

The Temporary grip for ADSS is a high strength aluminum body designed to hold 2,500 pounds or 50% of MRCL of the cable.

Application Notes:

1. Mechanical Grip for Use with Polyethylene Outer Jackets Only

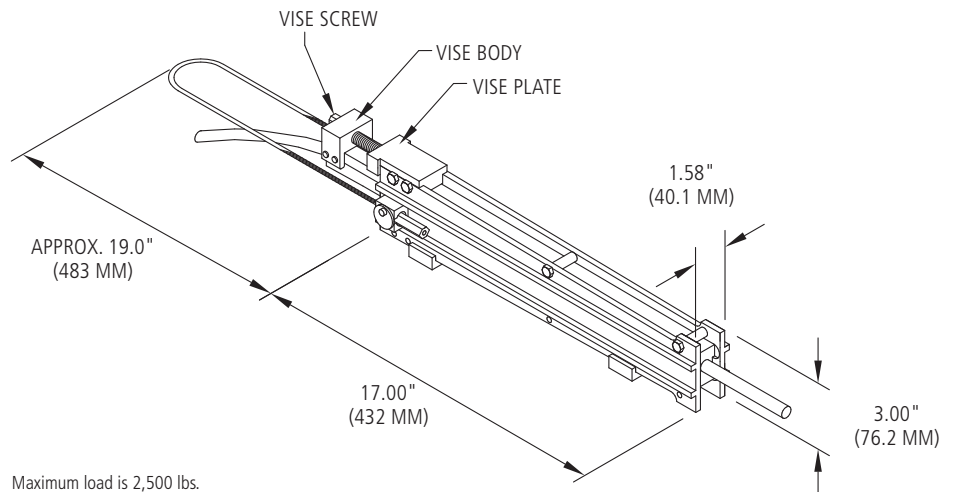

Maximum load is 2,500 lbs.

Thimble Clevis is included to attach temporary grip bail to chain hoist.

Ordering Information



Ordering Information for Additional Wedges

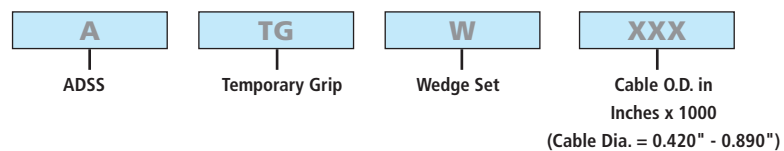

CAUTION:

1. The Temporary Grip is only to be used for AFL's ADSS fiber optic cables with standard polyethylene jackets with the O.D. ranging from 0.420" - 0.890" .
2. For cables with an O.D. outside of this range, please contact AFL.

Limited Tension Formed Wire Dead End for ADSS Cable

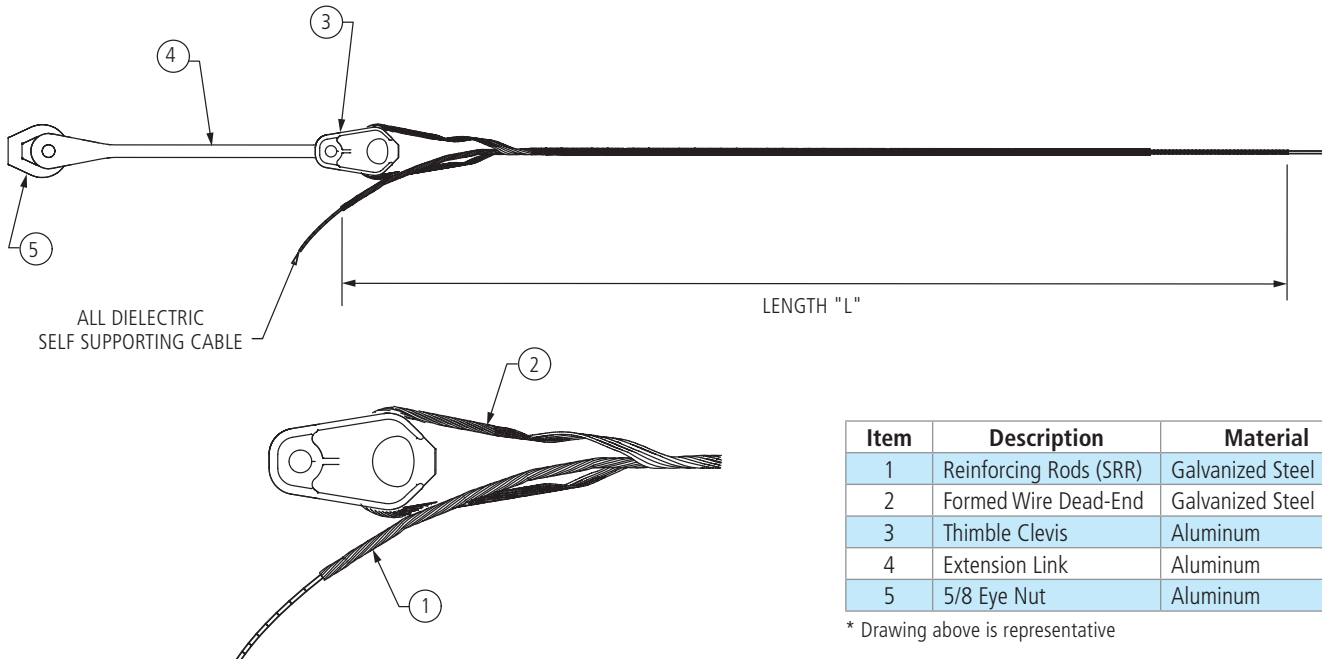

Item	Description	Material
1	Reinforcing Rods (SRR)	Galvanized Steel
2	Formed Wire Dead-End	Galvanized Steel
3	Thimble Clevis	Aluminum
4	Extension Link	Aluminum
5	5/8 Eye Nut	Aluminum

* Drawing above is representative

Features

- Components strength—6,500 lbs.
- Maximum initial tension—up to 1,000 lbs.
- Maximum loaded tension—up to 2,500 lbs.
- Dead end component may be reused once during initial installation
- Contact AFL for track-resistant ADSS application

Ordering Information

AFL NO.	CABLE OD (IN)	LENGTH "L" (IN)	COLOR CODE
ADESE380/400C	0.380 - 0.400	48	Red
ADESE400/424C	0.400 - 0.424	48	Black
ADESE425/451C	0.425 - 0.451	48	Yellow
ADESE452/481C	0.452 - 0.481	48	Green
ADESE482/510C	0.482 - 0.510	48	Orange
ADESE511/542C	0.511 - 0.542	48	Blue
ADESE543/577C	0.543 - 0.577	48	White
ADESE578/613C	0.578 - 0.613	48	Red
ADESE614/651C	0.614 - 0.651	48	Black
ADESE652/692C	0.652 - 0.692	48	Yellow
ADESE693/737C	0.693 - 0.737	48	Green
ADESE738/784C	0.738 - 0.784	48	Orange
ADESE785/834C	0.785 - 0.834	48	Blue
ADESE835/889C	0.835 - 0.889	48	White
ADESE890/945C	0.890 - 0.945	48	Red
ADESE946/1007C	0.946 - 1.007	48	Black
ADESE1008/1073C	1.008 - 1.073	60	Yellow
ADESE1074/1140C	1.074 - 1.140	60	Green
ADESE1141/1212C	1.141 - 1.212	60	Orange
ADESE1213/1288C	1.213 - 1.288	60	Blue

Medium Tension Dead End for ADSS Cable

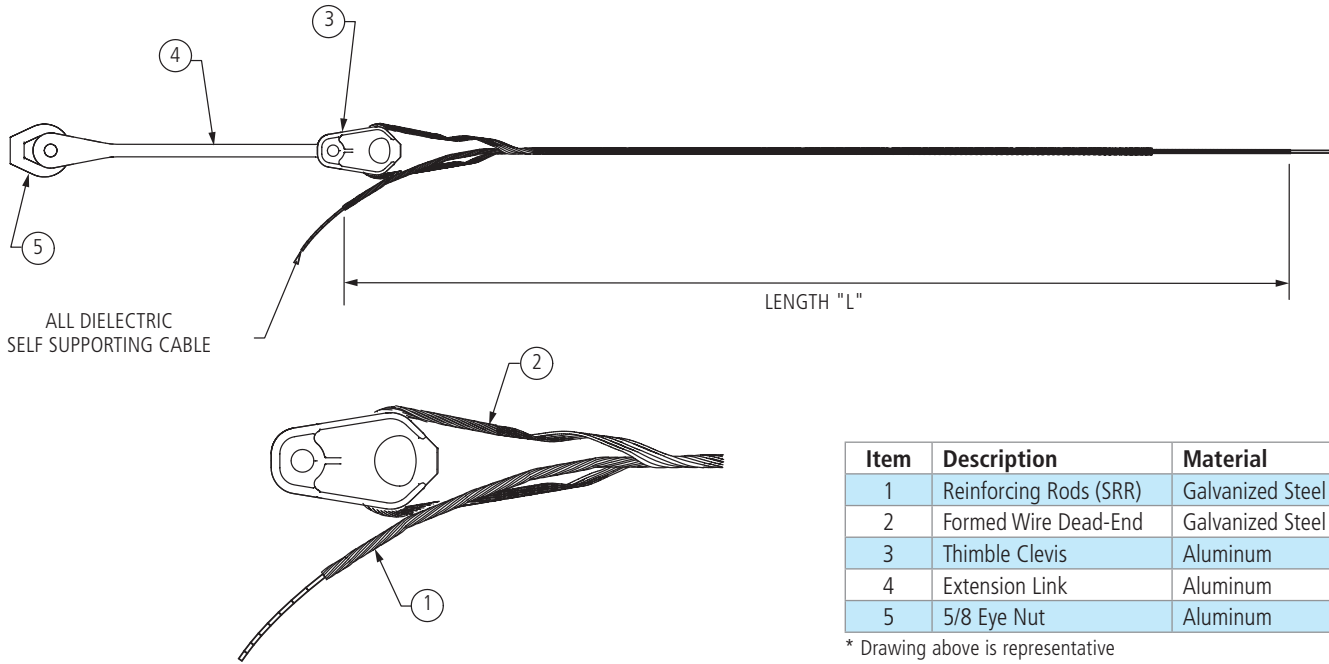

Features

- Component strength—6,500 lbs.
- Maximum initial tension—up to 2,000 lbs.
- Maximum loaded tension—up to 4,000 lbs.
- Dead end component may be reused once during initial installation
- Contact AFL for track-resistant ADSS application

Ordering Information

AFL NO.	CABLE OD (IN)	LENGTH "L" (IN)	COLOR CODE
ADEME482/510C	.482-.510	72	Orange
ADEME511/542C	.511-.542	73	Blue
ADEME543/577C	.543-.577	74	White
ADEME578/613C	.578-.613	78	Red
ADEME614/651C	.614-.651	80	Black
ADEME652/692C	.652-.692	80	Yellow
ADEME693/737C	.693-.737	82	Green
ADEME738/784C	.738-.784	88	Orange
ADEME785/834C	.785-.834	92	Blue
ADEME835/889C	.835-.889	94	White
ADEME890/945C	.890-.945	96	Red
ADEME946/1007C	.946-1.007	98	Black
ADEME1008/1073C	1.008-1.073	102	Purple
ADEME1074/1140C	1.074-1.140	102	Pink
ADEME1141/1212C	1.141-1.212	104	Brown
ADEME1213/1288C	1.213-1.288	107	Orange

Semi-High Tension Dead End for ADSS Cable

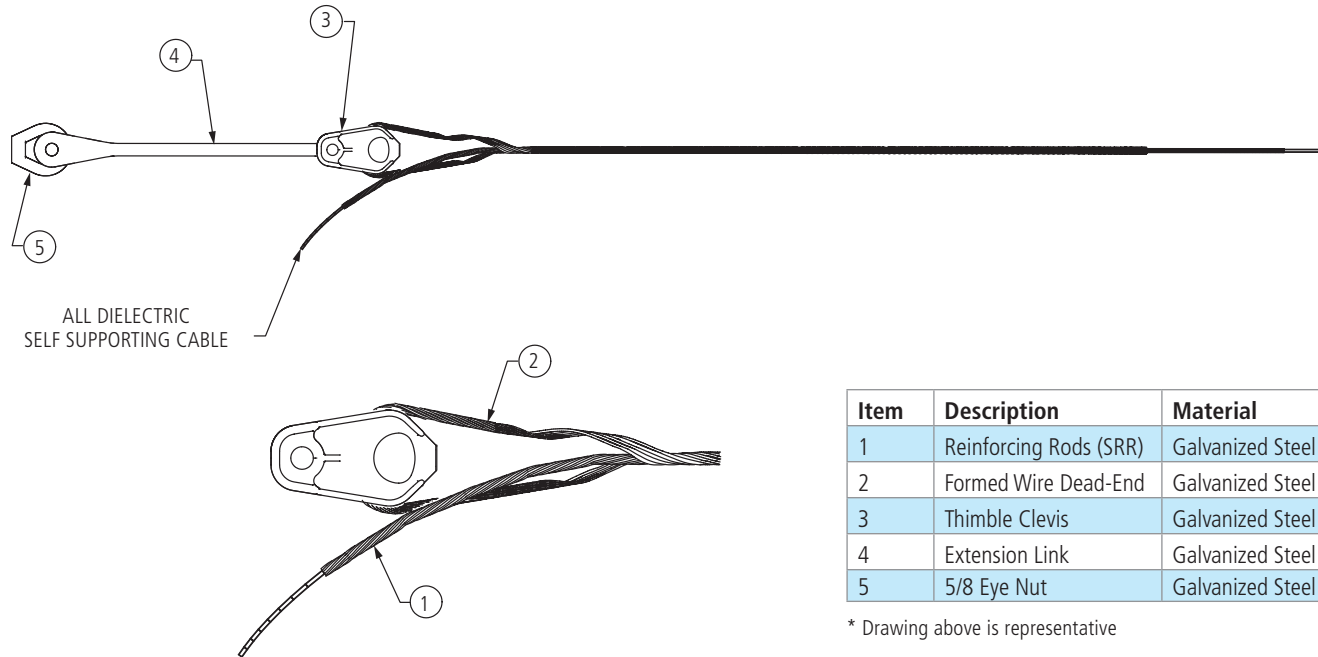

Item	Description	Material
1	Reinforcing Rods (SRR)	Galvanized Steel
2	Formed Wire Dead-End	Galvanized Steel
3	Thimble Clevis	Galvanized Steel
4	Extension Link	Galvanized Steel
5	5/8 Eye Nut	Galvanized Steel

* Drawing above is representative

Features

- Components strength—15,000 lbs.
- Maximum initial tension—up to 4,000 lbs.
- Maximum loaded tension—up to 7,500 lbs.
- Dead end component may be reused once during initial installation
- Contact AFL for Length Information and track-resistant ADSS application
- Lengths range from 100" to 134"

Ordering Information

AFL NO.	CABLE OD (in.)	LENGTH "L" (in.)	COLOR CODE
ADELE482/510C	.482-.510	98	Orange
ADELE511/542C	.511-.542	98	Blue
ADELE543/577C	.543-.577	100	White
ADELE578/613C	.578-.613	104	Red
ADELE614/651C	.614-.651	106	Black
ADELE652/692C	.652-.692	106	Yellow
ADELE693/737C	.693-.737	108	Green
ADELE738/784C	.738-.784	113	Orange
ADELE785/834C	.785-.834	118	Blue
ADELE835/889C	.835-.889	119	White
ADELE890/945C	.890-.945	121	Red
ADELE946/1007C	.946-1.007	123	Black
ADELE1008/1073C	1.008-1.073	126	Purple
ADELE1074/1140C	1.074-1.140	127	Pink
ADELE1141/1212C	1.141-1.212	129	Brown
ADELE1213/1288C	1.213-1.288	133	Orange

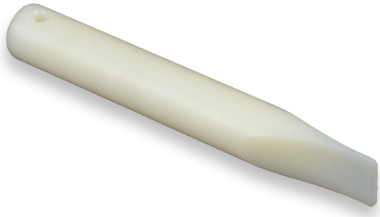

**AFL FIT
(Formed Wire Installation Tool)**

The nonmetallic AFL Fit Tool is used to install formed wire components without damaging the cable. Use of metal instruments to aid in the installation of formed wire components can result in cable damage.

Ordering Information:

AFL NO.
AFL-FIT

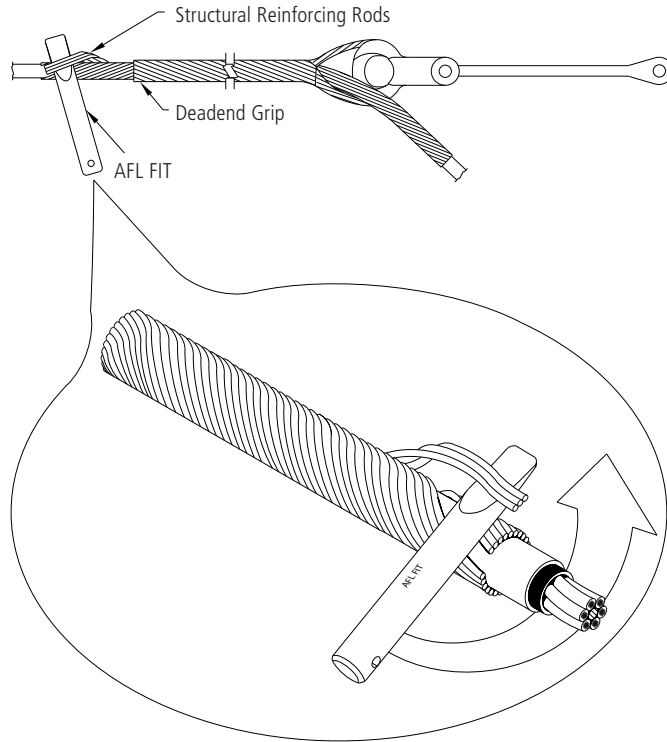

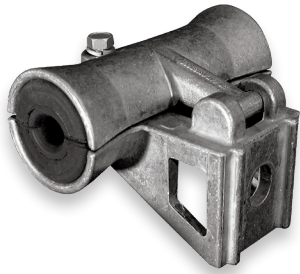

Single Trunnion Cable Support



Double Trunnion Cable Support (closed)



Double Trunnion Cable Support (open)

Trunnion Assemblies— Single and Double Cables

AFL offers trunnions with various mounting capabilities: bolted, banded or standoff. Trunnions reduce installation costs by functioning as a pull-through during installation (maximum line angle for stringing is 15° total, 7.5° per side, number of structures not to exceed 30). No block or pulley is needed provided these conditions are met.

Features

- May be used as a pull-through by removing the bushing inserts
- Double cable supports option
- High-strength aluminum
- Smaller and more compact design
- Facilitates faster installation
- Color-coded range taking inserts for easy identification
- Versatile mounting styles to fit different structure types: bolted, banded or standoff
- Banding and pole hardware supplied by customer
- Lowers the total cost of installation
- Span Length: 600 ft.—NESC Heavy
1,200 ft.—NESC Light

Ordering Information—Single Cable Support

AFL NO.	CABLE O.D. RANGE		ESTIMATED WEIGHT		BUSHING COLOR CODE
	INCHES	MILLIMETERS	LBS	KG	
ATGN325/375	0.325" - 0.375"	8.26 - 9.53	2.06	.934	Green + White
ATGN376/419	0.376" - 0.419"	9.55 - 10.64	2.06	.934	Orange + White
ATGN420/474	0.420" - 0.474"	10.67 - 12.05	2.05	.930	Purple + White
ATGN475/525	0.475" - 0.525"	12.07 - 13.34	2.05	.930	Blue
ATGN526/575	0.526" - 0.575"	13.36 - 14.61	2.05	.930	Orange
ATGN576/625	0.576" - 0.625"	14.63 - 15.88	2.04	.925	Brown
ATGN626/675	0.626" - 0.675"	15.90 - 17.15	2.04	.925	Green
ATGN676/725	0.676" - 0.725"	17.17 - 18.42	2.03	.921	White
ATGN726/775	0.726" - 0.775"	18.44 - 19.69	2.03	.921	Red
ATGN776/825	0.776" - 0.825"	19.71 - 20.96	2.02	.916	Purple
ATGN826/875	0.826" - 0.875"	20.98 - 22.23	2.02	.916	Yellow
ATGN876/925	0.876" - 0.925"	22.25 - 23.50	2.02	.916	Pink
ATGN926/959	0.926" - 0.959"	23.52 - 24.36	2.02	.916	Blue + White
ATGN960/1045	0.960" - 1.045"	24.38 - 26.54	2.02	.916	Gray

Application Notes:

1. For use with ADSS cables with polyethylene jackets in low voltage environments only. Not for use in high voltage environments where tracking resistant cables are required.
2. As a stringing block:
Maximum line angle = 15° (7.5° per side)
Maximum number of structures = 30
3. For final installation:
Maximum line angle = 22° (11° per side)

continued
→

Trunnion Assemblies (cont.)

Ordering Information—Double Tangent Support

BUSHING NUMBER		CABLE O.D. RANGE		BUSHING COLOR CODE	MAXIMUM SPAN CAPABILITIES USING NESC LOADS IN FEET/METERS	ESTIMATED WEIGHT	
"A"	"B"	INCHES	MM		HEAVY	LBS	KG
325	325	.325-.375	8.26-9.53	Green + White	600/182.9	4.00	1.814
376	376	.376-.419	9.55-10.64	Orange + White	600/182.9	4.00	1.814
420	420	.420-.474	10.67-12.04	Purple + White	600/182.9	3.99	1.810
475	475	.475-.525	12.07-13.34	Blue	600/182.9	3.99	1.810
526	526	.526-.575	13.36-14.61	Orange	600/182.9	3.99	1.810
576	576	.576-.625	14.63-15.88	Brown	600/182.9	3.98	1.805
626	626	.626-.675	15.90-17.15	Green	600/182.9	3.98	1.805
676	676	.676-.725	17.17-18.42	White	600/182.9	3.97	1.801
726	726	.726-.775	18.44-19.69	Red	600/182.9	3.97	1.801
776	776	.776-.825	19.71-20.96	Purple	600/182.9	3.96	1.796
826	826	.826-.875	20.98-22.23	Yellow	600/182.9	3.96	1.796
876	876	.876-.925	22.25-23.50	Pink	500/152.4	3.96	1.796
926	926	.926-.959	23.52-24.36	Blue + White	CONTACT AFL	3.96	1.796
960	960	.960-1.045	24.38-26.54	Gray	CONTACT AFL	3.96	1.796

How to Order

Order by assembling part number as shown:

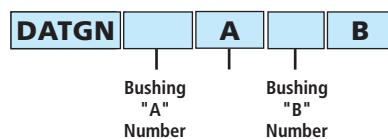

- Reference table above. See Note 1 below.
- Example:
 - First cable 0.500" OD → Bushing "A" number = 475
 - Second cable 0.750" OD → Bushing "B" number = 726
 - Order by part number: DATGN475A726B

Notes:

1. Bushing "A" and "B" may be the same or different.
2. Attachment hardware or stainless steel banding to be supplied by customer.

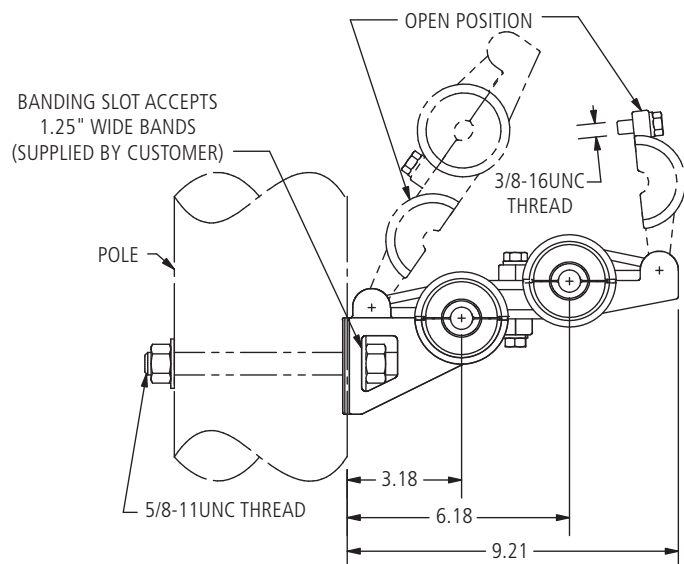

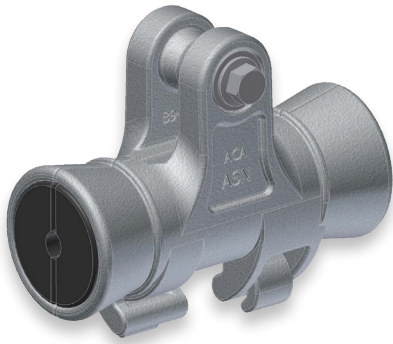

Correct orientation of bushing shown above.

Application Note:

1. For use with ADSS cables with polyethylene jackets in low voltage environments only. Not for use in high voltage environments where tracking resistant cables are required.

ADSS Suspension Unit

AFL's ADSS suspension unit is used to provide long term performance for spans up to 1200 feet (see span rating below). The interlocking halves of the aluminum body clamp provides positive alignment and utilize our proven EDPM bushings to gently grip the cable. The 3/8" mounting bolt is held captive by an o-ring. This product cannot be used as a stringing device.

Specifications

PARAMETER	VALUE
Span Length Rating	600 feet (200 meters) NESC Heavy 900 feet (274 meters) NESC Medium 1200 feet (365 meters) NESC Light
Vertical Load Rating	5000 lbs
Torque Requirement	Mounting bolt should be tightened to 25 ft-lb
Mounting Hardware	5/8" oval eye nut and anchor shackle (both parts not shown) can be included in the assembly by adding the suffix "AS01" to the part number
Line Angle	Max line angle is 30 degrees
Cable Types Recommended	For use on standard polyethylene jackets only DO NOT USE on track resistant cables
Slip Strength	Contact AFL for specific slip strength requirements

Ordering Information

AFL NO.	CABLE RANGE		WEIGHT		BUSHING COLOR CODE
	INCHES	MM	LBS	KG	
ASN325/375	0.325-0.375	8.3-9.5	2.2	1.0	Green + White
ASN376/419	0.376-0.419	9.6-10.6			Orange + White
ASN420/474	0.420 - 0.474	10.7 - 12.0			Purple + White
ASN475/525	0.475 - 0.525	12.1 - 13.3			Blue
ASN526/575	0.526 - 0.575	13.4 - 14.6			Orange
ASN576/625	0.576 - 0.625	14.6 - 15.9			Brown
ASN626/675	0.626 - 0.675	15.9 - 17.1			Green
ASN676/725	0.676 - 0.725	17.2 - 18.4			White
ASN726/775	0.726 - 0.775	18.4 - 19.7			Red
ASN776/825	0.776 - 0.825	19.7 - 21.0			Purple
ASN826/875	0.826 - 0.875	21.0 - 22.2			Yellow
ASN876/925	0.876 - 0.925	22.3 - 23.5			Pink
ASN926/959	0.926 - 0.959	23.5 - 24.4			—
ASN960/1045	0.960 - 0.1045	24.4 - 26.5			Gray

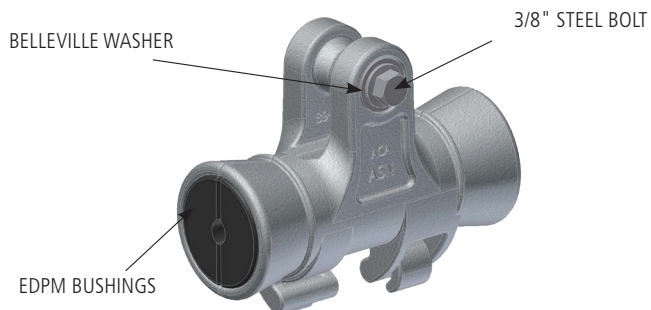

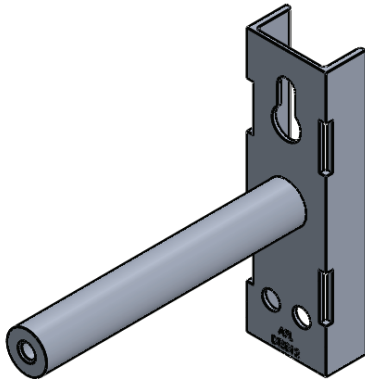

Standoff Bracket for ADSS Hardware Clamps

Features

- Aluminum material
- Positions the AFL ADSS trunnion or AFL ADSS suspension 14" off of structure
- Vertical load rating 1,250 lbs, horizontal load rating 1,250 lbs
- Attachment hardware supplied by customer
- Recommended hardware:
 - ATGN trunnion attachment to bracket:
 - 5/8-11 x 1-1/2" long hex head bolt
 - ASN suspension attachment to bracket:
 - 5/8-11 eyebolt and anchor shackle
 - Standoff bracket attachment to structure:
 - 5/8 bolt in top attachment hole
 - 1/2 or 5/8 lag screw in bottom hole(s)
 - 1-1/2 or 1-5/8 banding through both top and bottom banding slots

Ordering Information

AFL NO.	DESCRIPTION	WEIGHT
DTSB12	14" Standoff Bracket for AFL's ATGN Trunnion Clamp or ASN Suspension Clamp for use with ADSS Fiber Optic Cable	2.5 lbs.

Dimensions

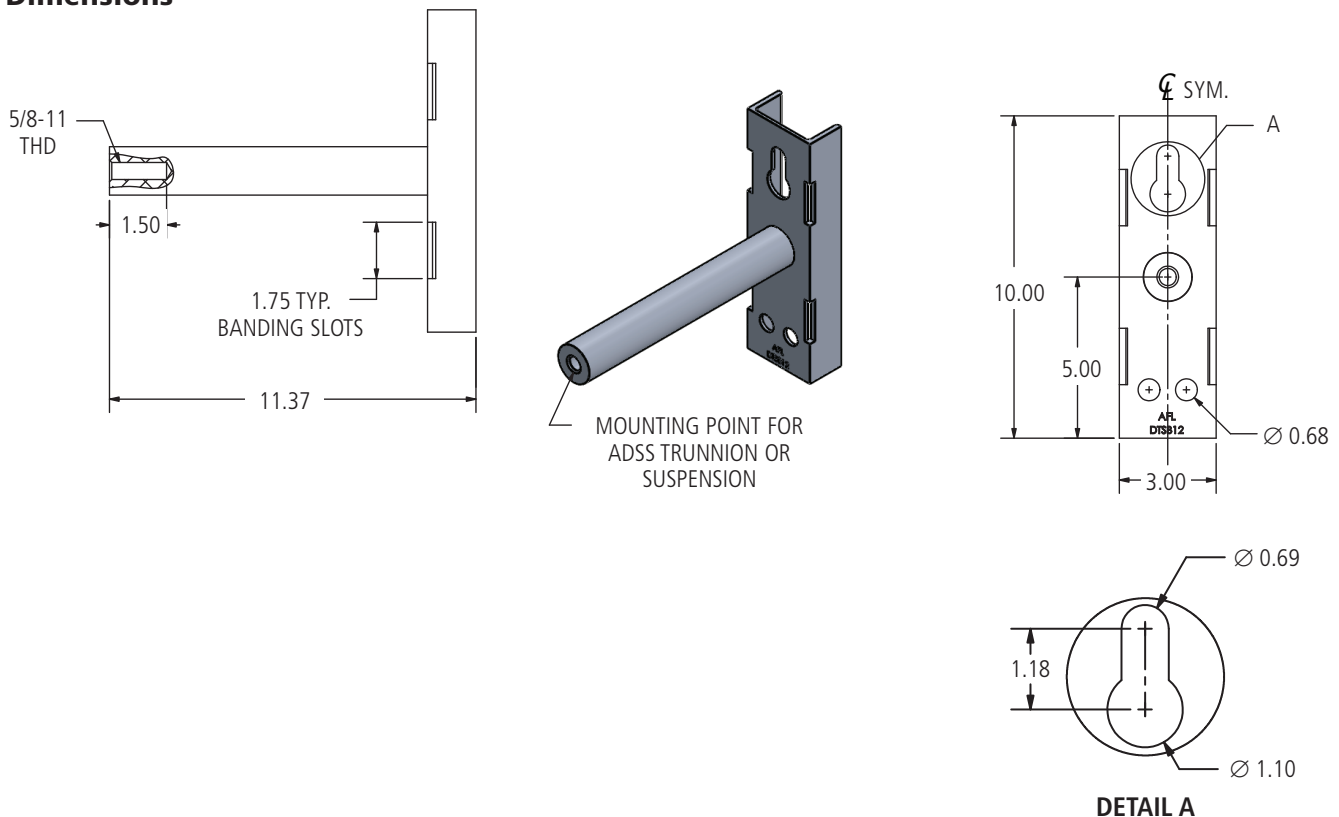

Formed Wire Suspension for ADSS Cable

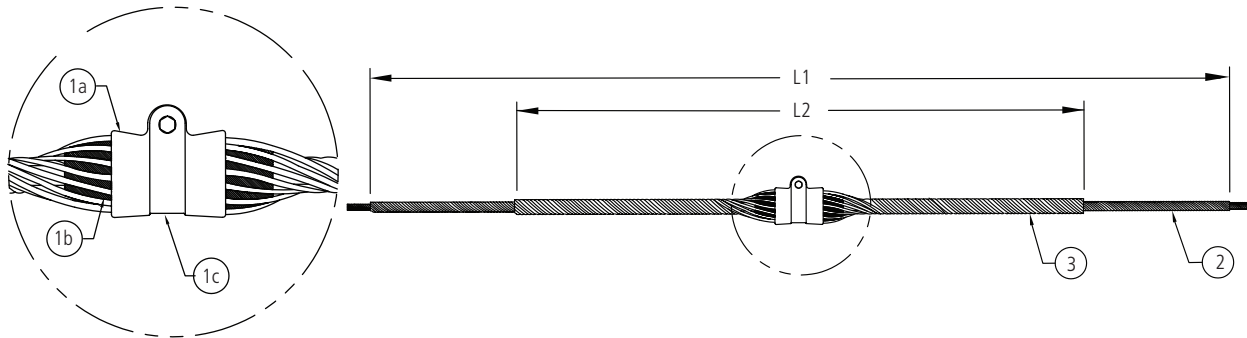

Features

- For line or elevation angle changes less than 30°
- Max vertical load—20,000 lbs.

Item	Description	Material
1a,c	Suspension Housing	Aluminum Alloy
1b	Insert (2 Halves)	Elastomer
2	Reinforcing Rods (SRR)	Aluminum Alloy
3	Outer Support Rods	Aluminum Alloy

Ordering Information

CABLE O.D. RANGE	STRUCTURAL REINFORCEMENT RODS				OUTER RODS				AFL NO.
	LENGTH "L1" (INCHES)	ROD DIA. (INCHES)	RODS PER SET	COLOR CODE	LENGTH "L2" (INCHES)	ROD DIA. (INCHES)	RODS PER SET	COLOR CODE	
0.399" - 0.418"	80	.146	10	Yellow	42	.204	11	Yellow	ASU399/418
0.419" - 0.439"	80	.146	10	Black	42	.204	11	Black	ASU419/439
0.440" - 0.458"	81	.146	11	White	43	.204	11	White	ASU440/458
0.459" - 0.461"	84	.167	10	Purple	46	.250	10	Orange	ASU459/461
0.462" - 0.476"	84	.167	10	Purple	46	.250	10	Purple	ASU462/476
0.477" - 0.503"	84	.146	12	Orange	46	.250	10	Orange	ASU477/503
0.504" - 0.511"	84	.146	12	Red	46	.250	10	Purple	ASU504/511
0.512" - 0.536"	87	.167	11	Blue	49	.250	11	Blue	ASU512/536
0.537" - 0.559"	87	.167	11	Green	49	.250	11	Green	ASU537/559
0.560" - 0.565"	87	.167	11	Green	49	.250	11	Green	ASU560/565
0.566" - 0.573"	92	.182	11	Black	54	.250	12	Black	ASU566/573
0.574" - 0.598"	92	.182	11	Black	54	.250	12	White	ASU574/598
0.599" - 0.625"	92	.182	12	Brown	54	.310	12	Brown	ASU599/625
0.626" - 0.632"	102	.204	11	Red	63	.310	11	Red	ASU626/632
0.633" - 0.666"	102	.204	11	Red	63	.310	11	Blue	ASU633/666
0.667" - 0.682"	102	.204	12	Yellow	63	.310	11	Green	ASU667/682
0.683" - 0.710"	102	.204	12	Yellow	63	.310	11	Yellow	ASU683/710
0.711" - 0.728"	102	.204	12	White	63	.310	12	Black	ASU711/728
0.729" - 0.744"	102	.204	12	White	63	.310	12	White	ASU729/744
0.745" - 0.750"	102	.204	12	White	63	.310	12	White	ASU745/750
0.751" - 0.786"	102	.204	13	White	63	.310	12	Brown	ASU751/786
0.787" - 0.814"	111	.250	11	Green	72	.365	11	Green	ASU787/814
0.815" - 0.845"	111	.250	12	Yellow	72	.365	11	Yellow	ASU815/845
0.846" - 0.855"	111	.250	12	Green	72	.365	12	Blue	ASU846/855
0.856" - 0.894"	119	.250	12	Black	80	.365	12	Black	ASU856/894
0.895" - 0.907"	119	.250	12	White	80	.365	12	White	ASU895/907
0.908" - 0.916"	119	.250	13	Purple	80	.365	12	Purple	ASU908/916
0.917" - 0.929"	119	.250	13	Brown	80	.365	12	Brown	ASU917/929
0.930" - 0.942"	119	.250	13	Red	80	.365	12	Red	ASU930/942
0.943" - 0.977"	119	.250	13	Orange	80	.365	13	Orange	ASU943/977



Download Clamp shown with Adapter B

Download Clamp for ADSS (with or without Unequal Diameters)

AFL Download Clamps are used to guide ADSS wire from the top of the structure to the splice box. Our clamps install easily and provide proper spacing and hold strength without damage to the cable. From poles to towers, we offer a full line of ADSS Download Clamps to meet the needs of any application.

Features

- Slip strength: >100 lbs.
- Lattice adapters provided with break-away bolts for precise torque during installation
- Steel tower guide clamps available with adapters to eliminate the need for drilling
- Banding adapters available

Ordering Information – Download Clamp and Adapter

BUSHING DESIGNATION	DIAMETER (INCHES)	COLOR CODE
B4	0.350 - 0.500	red
B5	0.501 - 0.600	green
B6	0.601 - 0.700	yellow
B7	0.701 - 0.800	blue
B8	0.801 - 0.900	white
B9	0.901 - 1.000	black
B10	1.001 - 1.100	orange

FD	OA	XX	YY	Z	M
Fiber Download	OPGW and ADSS	Bushing Designation (Smaller Dia.)	Bushing Designation (Larger Dia.)	Indicates Adapters A = Banding Adapter B = Lattice Adapter for web thickness 0.25" - 0.72" C = Lattice Adapter for web thickness 0.72" - 1.25" D = 3/8" diameter x 4" lag bolt E = Lattice Adapter for web thickness 0.25" - 1.25" Omit = No adapter desired	M for Metric Hardware

Ordering Example

For 0.528" dia. OPGW and 0.484 ADSS with pole banding (Type A), the part number is FDOA-B4B5A.

- NOTES:** 1. If metric hardware is desired, add a "M" suffix to the end.
2. See next page for optional download clamp adapters.

Download Clamp and Optional Download Clamp Adapters

Dimensions

FIG. 1

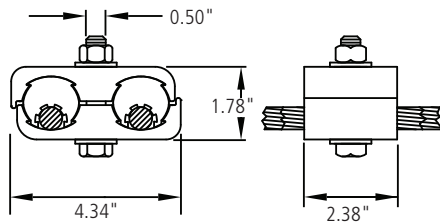

FDOA XXYX
NO ADAPTER

FIG. 2

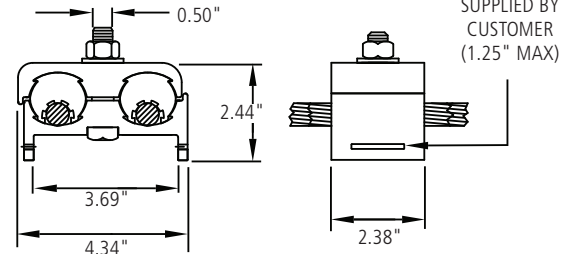

Download Clamp Adapters

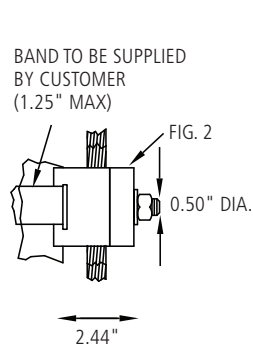

FDOA XXYXA

TYPE A ADAPTER WITH FIG. 2 BANDING CONFIGURATION
EST. WEIGHT: 0.96 LBS.

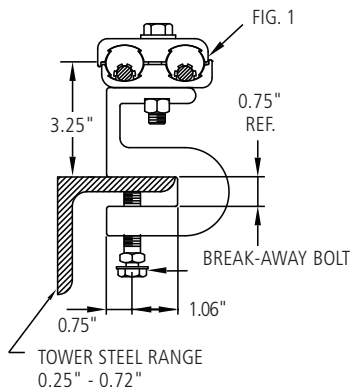

FDOA XXYXB

TYPE B ADAPTER WITH FIG. 1 LATTICE CONFIGURATION
EST. WEIGHT: 1.98 LBS.

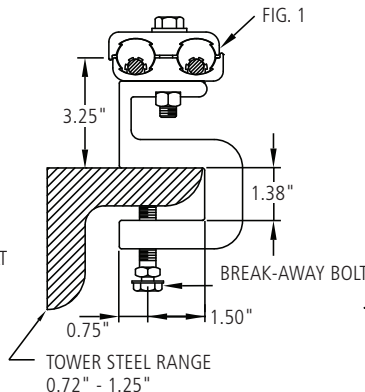

FDOA XXYXC

TYPE C ADAPTER WITH FIG. 1 LATTICE CONFIGURATION
EST. WEIGHT: 2.20 LBS.

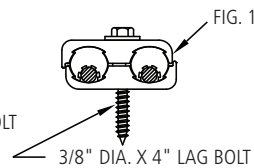

FDOA XXYXD

TYPE D ADAPTER WITH FIG. 1 LATTICE CONFIGURATION
EST. WEIGHT: 0.96 LBS.

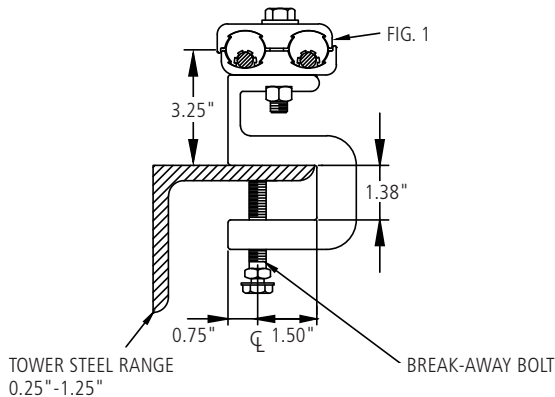

FDOA XXYXE

TYPE E ADAPTER WITH FIG. 1 LATTICE CONFIGURATION
EST. WEIGHT: 2.20 LBS.

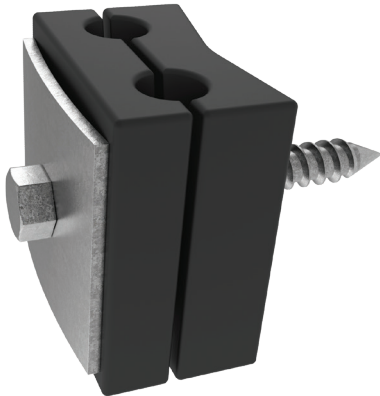

AGC Series ADSS Downlead Clamp with galvanized steel hardware

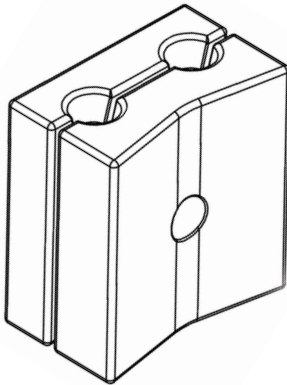

AGC Series ADSS Downlead Clamp

AFL's AGC Series Downlead Clamps are used to guide ADSS Fiber Optic Cable from the top of the structure to the splice location. Our clamps install easily and provide proper spacing and hold strength without damage to the cable. From poles to towers, we offer a full line of ADSS Downlead Clamps to meet the needs of any application.

Features

- Compressive elastomer material protects cable jacket
- Galvanized lag screw, square curved washer and standard round washers included

Ordering Information

AFL NO.	GROOVE CODE	CABLE DIAMETER (INCHES)		DIMENSIONS (INCHES)
		MIN.	MAX.	A
AGC468468D	468	0.375	0.468	2.75
AGC562562D	562	0.469	0.562	2.75
AGC656656D	656	0.563	0.656	2.75
AGC750750D	750	0.657	0.750	2.75
AGC849849D	849	0.751	0.849	3.00
AGC948948D	948	0.850	0.948	3.00
AGC105105D	105	0.949	1.050	3.00

Note: Alternative configurations are available. Please contact AFL for additional information.

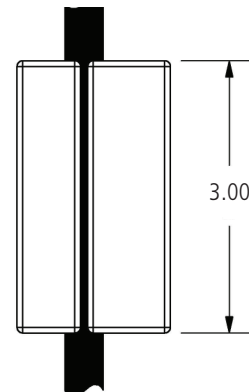
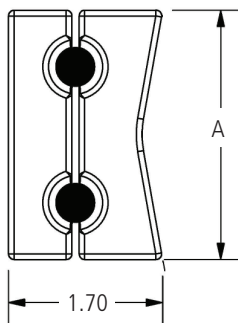
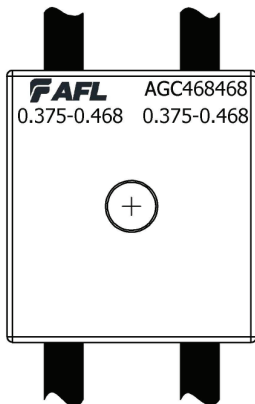



FDCT-4D

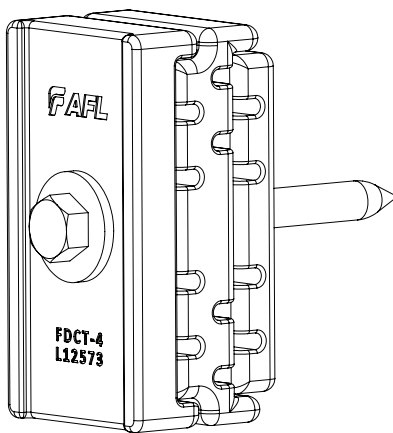

FDCT-12D

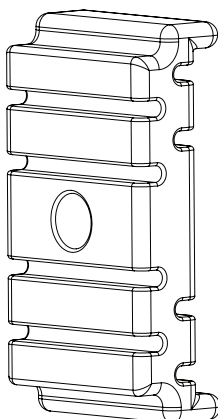

FDCT-5-12

Adapter may be ordered separately for increase in flat drop count

FDCT Series Flat Drop Cable Tangent/Download

The Flat Drop Cable Tangent accessory provides a means of suspending the flat drop cable to structures where termination is undesirable. The accessory can also be used in download applications to guide flat drop cables from the top of the structure to the splice box.

Features

- Compressive elastomer material protects cable jacket
- Lag screw attachment hardware kit available
- Can be banded or bolted in download applications

Ordering Information

AFL NO.	FLAT DROP CAPACITY	HARDWARE INCLUDED
FDCT-4	up to 4	—
FDCT-12	up to 12	—
FDCT-4D	up to 4	Lag screw hardware kit
FDCT-12D	up to 12	Lag screw hardware kit

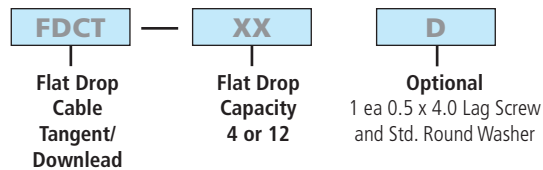

Ordering Example: To hold up to 12 flat drop cables, with lag screw hardware kit included, order part number FDCT-12D.

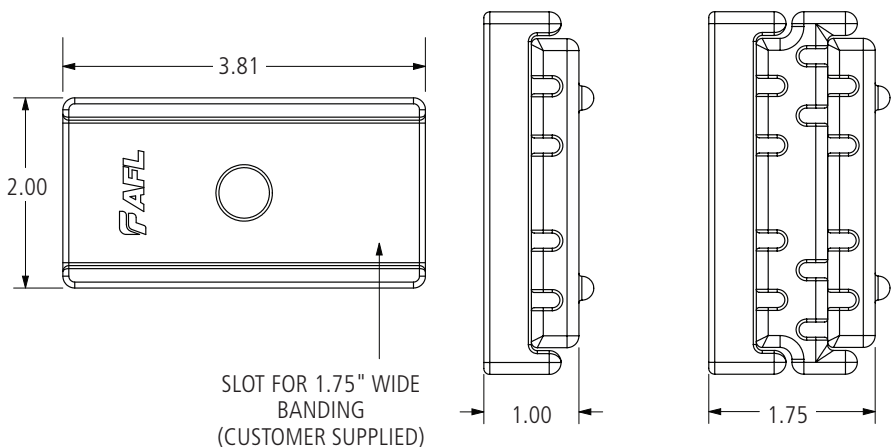



RDCT Series Round Drop Cable Tangent/Download

The Round Drop Cable Tangent accessory provides a means of suspending the round drop cable to structures where termination is undesirable. The accessory can also be used in download applications to guide round drop cables from the top of the structure to the splice box.

Features

- Compressive elastomer material protects cable jacket
- Lag screw attachment hardware kit available
- Can be banded or bolted in download applications
- Max cable diameter: 0.336"

Ordering Information

AFL NO.	ROUND DROP CAPACITY	HARDWARE INCLUDED
RDCT-4	Up to 4	—
RDCT-4D	Up to 4	Lag screw hardware kit

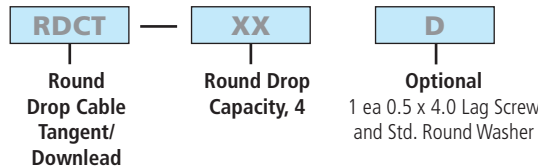

Ordering Example: To hold four (4) round drop cables with lag screw hardware kit included, order part number RDCT-4D.

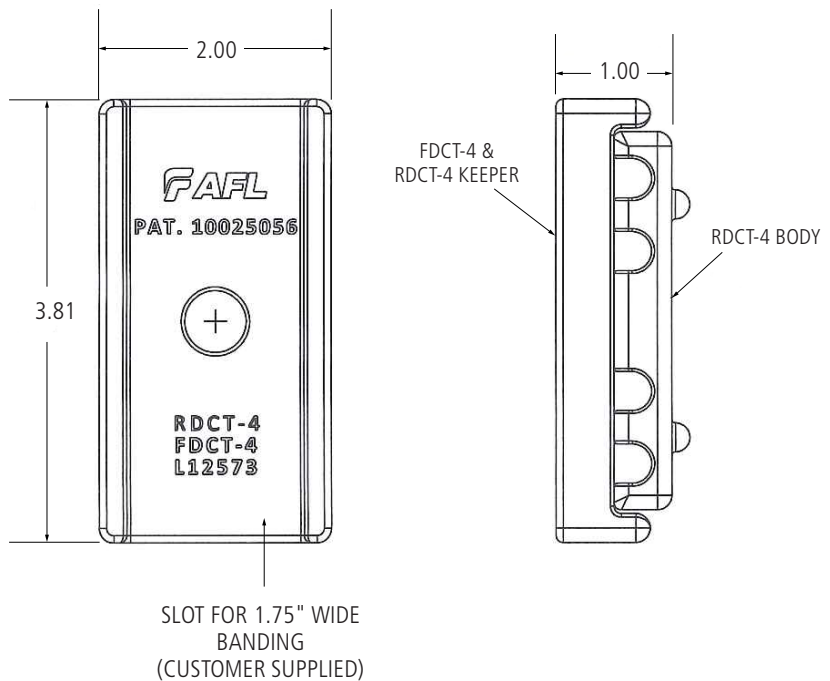
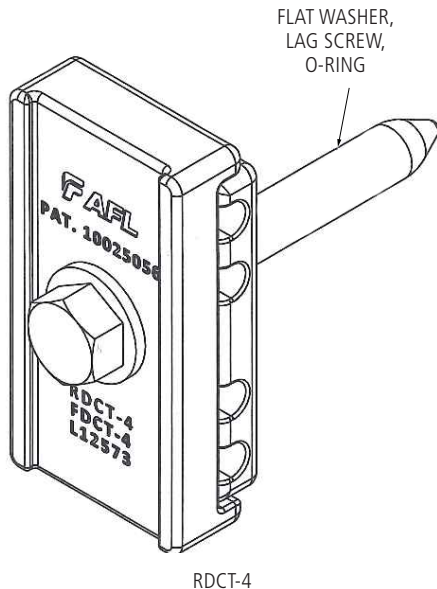



Multi-Drop Thimble Eye for Round Drop ADSS

The AFL Multi-Drop Thimble Eye is used to anchor aerial round drop cables to the distribution structure. The uniform radial slots can accommodate up to four formed wire deadends per thimble eye and support tensioning up to 90 degrees from the installation hardware. This is particularly useful when double deadending is required.

Features

- Anchors up to four aerial drop cables
- Supports tensioning 90° from installation hardware
- Slot base for ease of installation

Ordering Information

AFL NO.	RATED STRENGTH (LBS.)	APPROX. WEIGHT (LBS.)
MDTE4-S	8,000	1.75

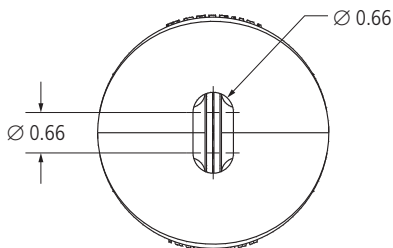
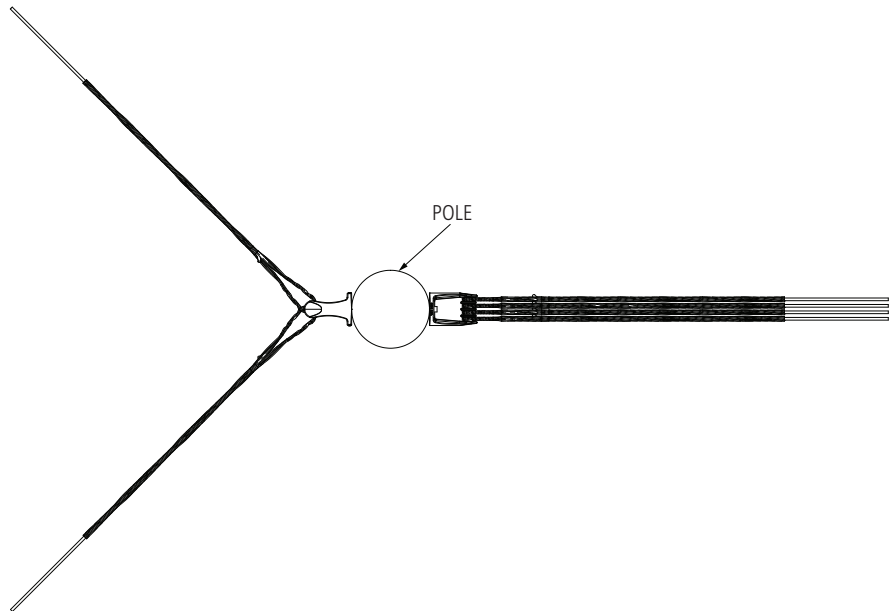
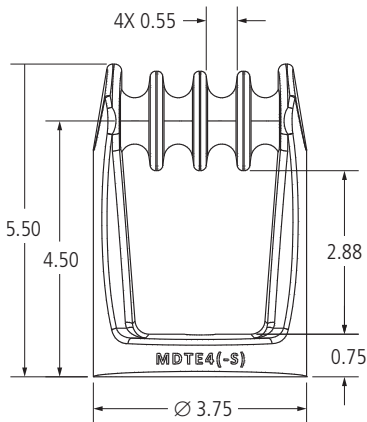

SVD Series Spiral Vibration Dampers

AFL's SVD Series Spiral Vibration Dampers are designed to eliminate the damage caused by Aeolian vibration and reduce overall vibration on bare cables. Made of weather-resistant, non-corrosive plastic, these dampers have a large, helically-formed damping section sized for the cable. A smaller gripping section gently grips the cable. Each damper is marked with the conductor range and color coded to indicate the cable diameter size range.

Line design, temperature, tension, wind flow exposure and history of vibration on similar construction in the location are factors to consider when determining the amount of protection required. Installation can be on both sides of the support location—at least one hand-width from the ends of Armor Rods or cable hardware. Depending on the customer's specific conditions, AFL recommends the SVD Spiral Vibration Damper in accordance with the recommended application chart for the following:

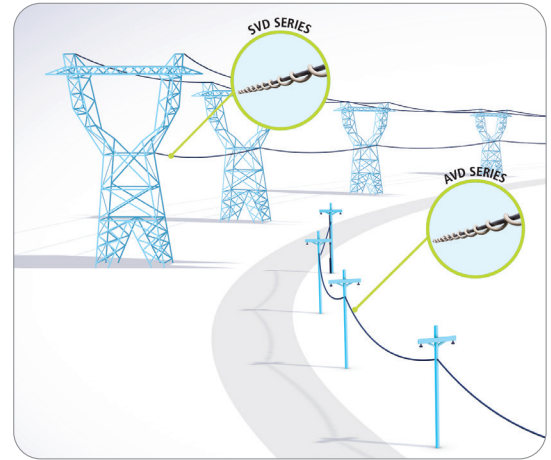

- Conductors between 0.250 inches and 0.500 inches O.D. (used with tietop insulators and rural construction)
- Optical Ground Wires (OPGW) and Overhead Ground Wires (OHGW) in accordance with the recommended application chart

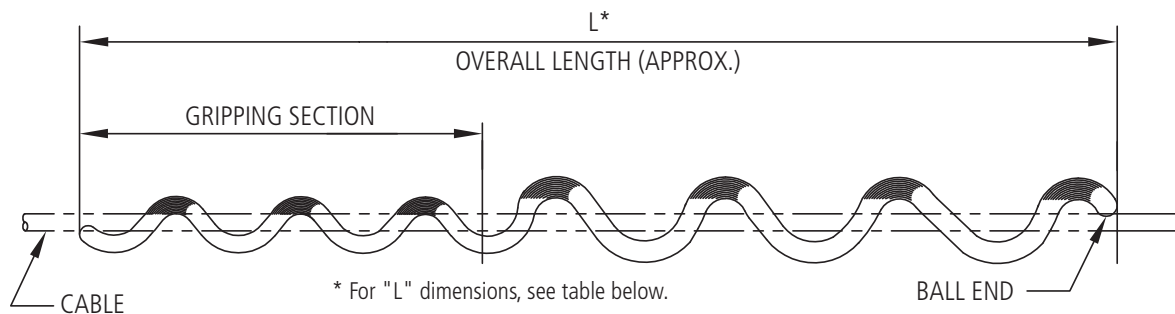

Ordering Information

Select catalog number based on cable diameter. Example: for 0.512" diameter, order SVD462/563

Conductor Diameter Cross Reference

AFL NO.	PLP NO.	CONDUCTOR DIAMETER RANGE INCHES (MM)	"L" ROD LENGTH INCHES (MM)	WEIGHT LBS (KG)	COLOR CODE	STANDARD PACK
SVD250/326	5050103	0.250-0.326 (6.35-8.29)	49 (1244)	29 (13.154)	Light Blue	50
SVD327/461	5050104	0.327-0.461 (8.30-11.72)	51 (1295)	31 (14.061)	Black	50
SVD462/563	5050105	0.462-0.563 (1.73-14.32)	53 (1346)	34 (15.422)	Yellow	50
SVD564/770	5050106	0.564-0.770 (14.33-19.30)	64 (1625)	50 (22.679)	Green	25

High Mass Cross Reference

AFL NO.	PLP NO.	CONDUCTOR DIAMETER RANGE INCHES (MM)	"L" ROD LENGTH INCHES (MM)	WEIGHT LBS (KG)	COLOR CODE	STANDARD PACK
SVD250/326HM	5050200	0.250-0.326 (6.35-8.29)	87 (2209)	55 (24.948)	Light Blue	50
SVD327/461HM	5050201	0.327-0.461 (8.30-11.72)	91 (2311)	60 (27.216)	Black	50
SVD462/563HM	5050202	0.462-0.563 (1.73-14.32)	94 (2387)	65 (29.483)	Yellow	50
SVD564/770HM	5050203	0.564-0.770 (14.33-19.30)	96 (2438)	55 (24.948)	Green	25

continued
→

SVD Series Spiral Vibration Dampers (cont.)

Damper Recommendations for Placement

Damper Recommendation applies for specified AFL dampers only. If alternative type or different manufacturer dampers are applied instead, it is possible that damage will occur on the conductor and/or the accessories.

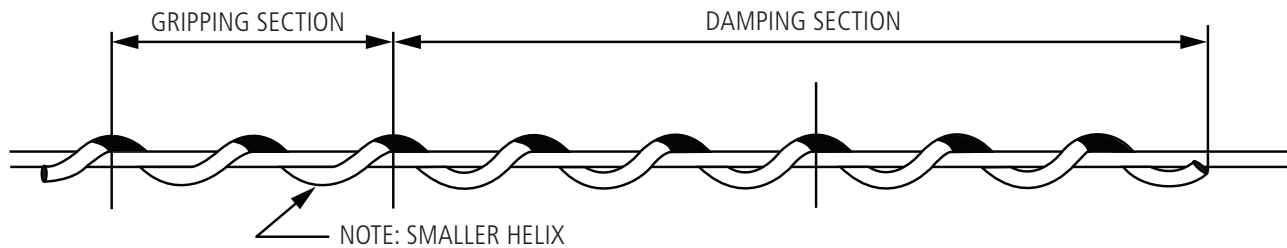

SPAN LENGTH	INITIAL TENSION PERCENTAGE OF CABLE RATED BREAKING STRENGTH AT NOMINAL TEMPERATURE 60°F							
	0-10%		11-15%		16-20%		>20%	
	STANDARD	HIGH MASS	STANDARD	HIGH MASS	STANDARD	HIGH MASS	STANDARD	HIGH MASS
< 800 ft.	2/s	1/s	2/s	1/s	4/s	2/s	4/s	2/s
801-1400 ft.	4/s	2/s	4/s	2/s	6/s	4/s	6/s	4/s
1401-2400 ft.	6/s	4/s	6/s	4/s	8/s	4/s	8/s	4/s
2401-3000 ft.	8/s	4/s	8/s	4/s	10/s	6/s	10/s	6/s
3001-3500 ft.	10/s	6/s	10/s	6/s	12/s	6/s	12/s	6/s
3501-4000 ft.	12/s	6/s	12/s	6/s	16/s	8/s	16/s	8/s
4001-4500 ft.	16/s	8/s	16/s	8/s	18/s	10/s	18/s	10/s
4501-5000 ft.	18/s	10/s	18/s	10/s	20/s	10/s	20/s	10/s

Symbol Designation

- 2/s = 2 dampers per span, 1 on each end of the span
- 4/s = 2 dampers in tandem on each end of the span
- 6/s = 3 dampers in tandem on each end of the span
- 8/s = 3 dampers in tandem + 1 damper on each end of the span
- 10/s = 3 dampers in tandem + 2 dampers in tandem on each end of the span
- 12/s = 3 dampers in tandem + 3 dampers in tandem on each end of the span
- 16/s = 3 dampers in tandem + 3 dampers in tandem + 2 dampers in tandem on each end of the span
- 18/s = 3 dampers in tandem + 3 dampers in tandem + 3 dampers in tandem on each end of the span
- 20/s = 3 dampers in tandem + 3 dampers in tandem + 3 dampers in tandem + 1 damper on each end of the span

Placement and Spacing

1. SVD shall be placed approximately 5 inches away from any line hardware (suspension, deadend, armor rods, other SVDs, etc.).
2. SVDs can be nestled in tandem for up to three units to prevent the units from interfering with each other.
3. SVDs shall be applied to bare cable only to ensure proper performance.

AVD Series Spiral Vibration Dampers

AFL's AVD Series Spiral Vibration Dampers are designed to eliminate the damage caused by Aeolian vibration and reduce overall vibration on bare All-Dielectric Self-Supporting (ADSS) cables. Made of weather-resistant, non-corrosive plastic, these dampers have a large, helically-formed damping section sized for the ADSS cable. A smaller gripping section gently grips the ADSS cable. Each damper is marked with the conductor range and color coded to indicate the cable diameter size range.

Line design, temperature, tension, wind flow exposure and history of vibration on similar construction in the location are factors to consider when determining the amount of protection required. Installation can be on both sides of the support location—at least one hand-width from the ends of Armor Rods or cable hardware. Depending on the customer's specific conditions, AFL recommends the AVD Spiral Vibration Damper for ADSS cable in accordance with the recommended application chart.

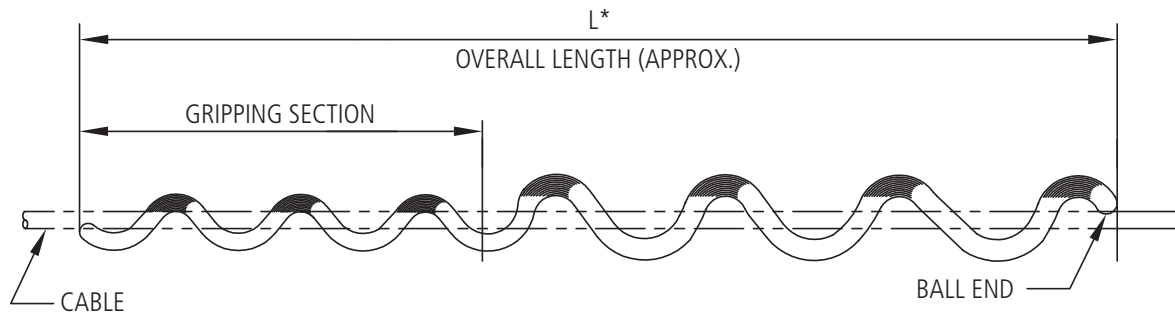
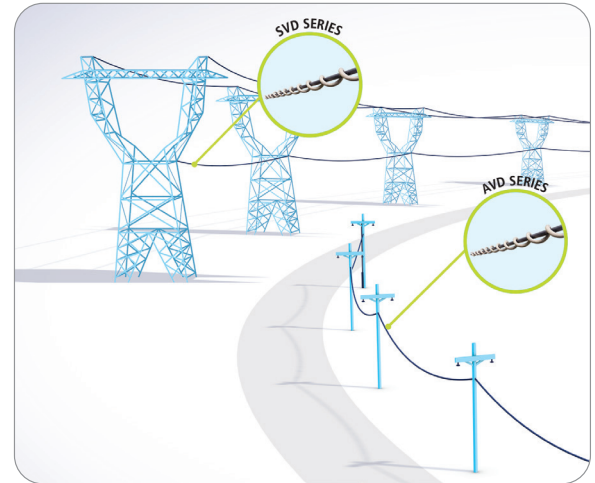

* For "L" dimensions, see table below.

Ordering Information

Select catalog number based on cable diameter. Example: for 0.512" diameter, order AVD462/563

Conductor Diameter Cross Reference

AFL NO.	PLP NO.	CONDUCTOR DIAMETER RANGE inches (mm)	"L" ROD LENGTH inches (mm)	WEIGHT lbs (KG)	STANDARD PACK
AVD250/326	50502393	0.250-0.326 (6.35-8.29)	49 (1244)	27 (12.247)	50
AVD327/461	50502272	0.327-0.461 (8.30-11.72)	51 (1295)	30 (12.701)	50
AVD462/563	50502274	0.462-0.563 (1.73-14.32)	53 (1346)	30 (13.608)	50
AVD564/770	50509862	0.564-0.770 (14.33-19.30)	64 (1625)	47 (21.319)	25
AVD771/876	50503057	0.771-0.876 (19.58-22.25)	71 (1803)	29 (13.154)	25
AVD877/1000	50503576	0.877-1.000 (22.26-25.40)	75 (1905)	36 (16.329)	25
AVD1001/1250	50503909	1.001-1.250 (25.41-31.75)	90 (2286)	41 (18.597)	25

continued
→

AVD Series Spiral Vibration Dampers (cont.)

Damper Recommendations for Placement

Damper Recommendation applies for specified AFL dampers only. If alternative type or different manufacturer dampers are applied instead, it is possible that damage will occur on the conductor and/or the accessories.

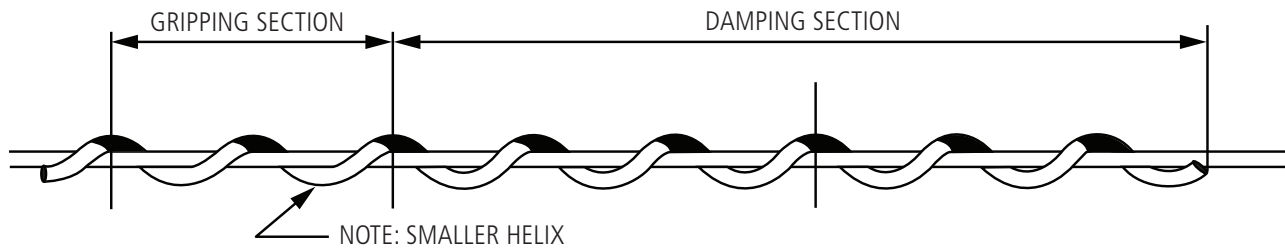

SPAN LENGTH	INITIAL TENSION PERCENTAGE OF CABLE RATED BREAKING STRENGTH (RBS) AT NOMINAL TEMPERATURE 60°F				
	0-10%	11-15%	16-20%	21-25%	>25%
< 250 ft.	0	2/s	2/s	2/s	2/s
251-500	2/s	2/s	2/s	2/s	4/s
501-800	2/s	2/s	2/s	4/s	4/s
801-1600	4/s	4/s	4/s	6/s	6/s
1601-2400	6/s	6/s	6/s	8/s	8/s
2401-3000	8/s	8/s	8/s	10/s	10/s
3001-3500	10/s	10/s	10/s	12/s	12/s
3501-4000	12/s	12/s	12/s	16/s	16/s
4001-4500	16/s	16/s	16/s	16/s	18/s
4501-5000	18/s	18/s	18/s	18/s	20/s

Symbol Designation

- 2/s = 2 dampers per span, 1 on each end of the span
- 4/s = 2 dampers in tandem on each end of the span
- 6/s = 3 dampers in tandem on each end of the span
- 8/s = 3 dampers in tandem + 1 damper on each end of the span
- 10/s = 3 dampers in tandem + 2 dampers in tandem on each end of the span
- 12/s = 3 dampers in tandem + 3 dampers in tandem on each end of the span
- 16/s = 3 dampers in tandem + 3 dampers in tandem + 2 dampers in tandem on each end of the span
- 18/s = 3 dampers in tandem + 3 dampers in tandem + 3 dampers in tandem on each end of the span
- 20/s = 4 dampers in tandem + 3 dampers in tandem + 3 dampers in tandem on each end of the span

Placement and Spacing

1. AVD shall be placed approximately 5 inches away from any line hardware (suspension, deadend, armor rods, other SVDs, etc.).
2. AVDs can be nested in tandem for up to three units to prevent the units from interfering with each other.
3. AVDs shall be applied to bare cable only to ensure proper performance.



Fiber Storage Units for ADSS Fiber Optic Cable

AFL Fiber Storage Units (FSU) are used to conveniently store an extra length of cable along the ADSS cable run for later use. Furnished as pairs (kit contains two Fiber Storage Units and two sets of hanger brackets), these FSUs are constructed from UV stabilized PPE thermoplastic. All basic hardware for attachment to the ADSS cable is provided. ADSS cable mount support brackets meet Telcordia® specifications. Epoxy coated clamping devices meet ASTM specifications A153 and B695.

Features

- Small profile and side facing channel minimizes ice and leaf loading
- Constructed from UV stabilized PPE thermoplastic
- Basic hanging hardware (bolts, nuts, washers) and strand clamps all included
- Tie-wrap slots for securing cable
- Epoxy-coated strand clamps

The mounting bracket features an angled, tent-profile, epoxy-coated bracket for standard ADSS cable mounting.

Specifications

PARAMETER	FOSP-ADSS-12	FOSP-ADSS-17
Nominal Channel Width - in. (cm)	0.625	1.00
Minimum Bend Diameter - in. (cm)	12	17.5

Ordering Information

DESCRIPTION	FOSP-ADSS-12	FOSP-ADSS-17
FOS ADSS Kit	FA000049	FA000050

Kits contain one pair of FOSP and two sets of hanger brackets.

Qualifications

GOVERNING BODY	STANDARD CODE
ASTM	ASTM A153, ASTM B695

Typical Installation Diagram

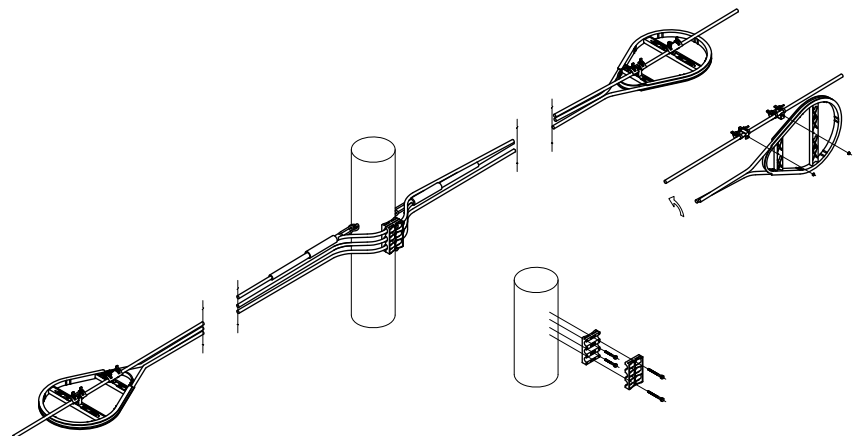

Corona Ring for ADSS Cable

Ordering Information

A	CR	XXX
ADSS CABLE	Corona Ring	Cable Diameter in Decimal Inches

Ordering Example:

For a .685" diameter ADSS, the AFL number is ACR685

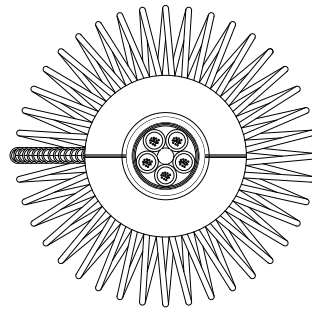

CORONA RING ASSEMBLY

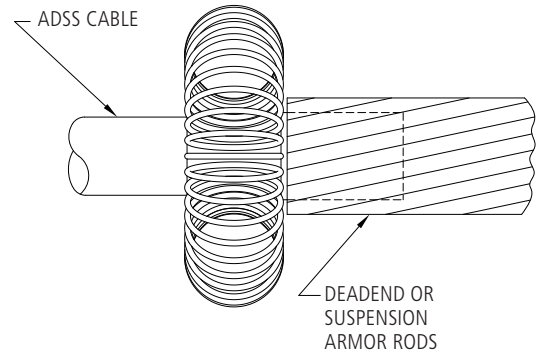

Note: Corona coil clamp component should be installed under the rods of the dead end or suspension.