

OPTICAL CONNECTIVITY

Rack Mount Panels | Optical Modules | Cable Assemblies | Components
Sealed & Aerial Splice Closures | Fiber Demarcation | Fiber Enclosures

Founded in 1984, AFL is an international manufacturer providing end-to-end solutions to the energy, service provider, enterprise, hyperscale and industrial markets as well as several emerging markets.

AFL's products are in use in over 130 countries and include fiber optic cable and hardware, transmission and substation accessories, outside plant equipment, connectivity, test and inspection equipment, and fusion splicing systems.

AFL also offers a wide variety of services supporting data center, enterprise, wireless and outside plant applications.

AFL is dedicated to bringing our customers a quality product as well as delivering superior value.



Table of Contents

Pre-Terminated Cable Assemblies

Simplex Cable Assemblies	3
Duplex Cable Assemblies	4
Multi-Fiber Cable Assemblies	5
MPO Cable Assemblies	7
NodeFLEX® Cable Assembly	9
Loose Tube and Riser Rated Indoor/Outdoor Cable Assemblies	10
MDU Drop Cable Assemblies	12
Fanout Kits	13
Connector Specifications	14

Connectivity Accessories

Buildout Attenuators	15
Optical Adapters	16
Optical Terminators	18
SpliceConnect with Tool Kit	19
Optical Coupler Modules	20
Planar Lightwave Circuit (PLC) Splitters	22

Couplers/Splitters and Multiplexers

Wideband Couplers	23
Ruggedized Wideband Couplers	24
Optical Splitter Shelf	25
Optical FTTx Coupler Module	26
LGX® FTTx Splitter Modules	27
CWDM LGX Modules	28
CGM® PLUS	31
Card Guide Module (CGM®)	32
CWDM Single-channel OADM	33
Dense Wave Division Multiplexing (DWDM) Single Fiber OADM	35
DWDM LGX Modules	38
DWDM Cassette Modules	41
DWDM Card Guide Modules (CGM®)	44
DWDM Rack-Mount Panels	47
RFoG WDM Module	50
LGX® FTTx WDM Modules	51

Field-Installable Connectors

FASTConnect® Field-Installable Connectors	52
FUSEConnect® Field-Installable Connectors	54
FUSEConnect MPO Splice-On, Field-Installable Connectors with Heat Sleeve	56
FASTConnect® Universal Tool Kit	58
FUSEConnect® Tool Kit and Accessories	59

Fiber Management

LightLink LANSystem

1RU Fiber Termination Patch/Splice Panel	60
2RU Fiber Termination Patch/Splice Panel	62
3RU Fiber Termination Patch Panel	64
4RU Fiber Termination Patch Panel	66
5RU Fiber Termination Patch Panel	68
6RU Fiber Patch and Splice Panel	70
7RU Fiber Patch and Splice Panel	72
8RU Fiber Patch and Splice Panel	74
10RU Fiber Patch and Splice Panel	76
SPL3RU and SPL5RU—Optical Splice Shelf	78

Xpress Fiber Management® (XFM®)

XFM 1RU Patch Panel	80
XFM 2RU Patch Panel	81
XFM 4RU Patch Panel	82
XFM 5RU Shelf	83
XFM-28 Dual Access Module Panel	84
XFM MPO Optical Cassettes	85

High Density Modular Platform

ASCEND® Fiber Housings	87
ASCEND Optical Cassettes	89
ASCEND Fanout Cassettes	90
ASCEND Mesh Cassettes NEW	92
ASCEND Patch Cassettes	93
ASCEND Splice Cassettes	94
ASCEND Conversion Cassettes	95
ASCEND Tap Cassettes	97
ASCEND Patch Cord Assemblies	101
ASCEND Trunk Cable Assemblies	102
ASCEND Outback Clip Management (OCM) Bracket	104
MTP® PRO Field Tool for Polarity/Pin Change	105

Modules and Panel Accessories

Poli-MOD® Patch and Splice Module	106
LightLink Adapter Plates	108
Pigtail Assemblies for Patch and Splice Panels	111

Wall Mount Interconnect Enclosure (WME)

WME01 with One LGX® Mounting Position	112
WME02 with Two LGX® Mounting Positions	114
WME04 with Four LGX® Mounting Positions	116
LightLink Optical Entrance Enclosures	119

Wall Mount Enclosures – Outdoor & Pedestal Mount

LL-5D Optical Splicing and Distribution Enclosure NEW	123
LightLink 580 Optical Splicing and Distribution Enclosure	126
LightLink 550 Optical Splicing and Distribution Enclosure	128
LightLink 500 Optical Splicing and Distribution Enclosure	130
LightLink 400sx Optical Splicing and Distribution Enclosure	131
LightLink 400b Optical Splicing and Distribution Enclosure	132
LightLink 24 Slim-Line Pedestal	133

DIN Mount Enclosures

Mini DIN Rail Mounted Enclosure	136
-------------------------------------------	-----

Fiber Demarcation

OptiNID® Duo Optical Demarcation Enclosure	137
OptiNID 300 Series Optical Demarcation Slack Storage Closure.	139
OptiNID 500 Optical Demarcation Closure	140
OptiNID 760XL Optical Demarcation Closure	141
OptiNID Optical Demarcation Accessories	142

Coax Demarcation

CableGuard 1000XL Coax Demarcation Enclosures	144
---------------------------------------------------------	-----

FTTx Splitter Cabinets and Accessories

IDEAA® Exterior Distribution Cabinet.	145
LL-400sx Optical Splicing/Distribution Enclosure	147
IDEAA® Rack Mount Bracket.	147
IDEAA Splice Closure—Sealed	148
IDEAA Interior Distribution Cabinet	149
IDEAA Interior Distribution Cabinet Accessories	150
IDEAA Mini Interior Distribution Cabinet	151

Fiber Optic Splice Closures

Sealed Fiber Optic Splice Closures	152
Apex® X-3 Sealed Splice Closure NEW	153
Apex® X-3H Sealed Splice Closure NEW	158
Apex® X-2 Sealed Splice Closure.	163
Apex® X-2S Sealed Splice Closure	169
LightGuard® (LG) Sealed Splice Closures	
LG Peel & Seal Grommet Systems for Sealed Splice Closures	175
LG-55 Sealed Fiber Optic Splice Closure	176
LG-55-SC Sealed Fiber Optic Splice Closure	177
LG-150 Sealed Fiber Optic Splice Closure	178
LG-250 Sealed Fiber Optic Splice Closure	180
LG-350 Sealed Fiber Optic Splice Closure	182
LG-350-20-WTC Sealed Fiber Optic Splice Closure.	184
LG-350-27-WTC Sealed Fiber Optic Splice Closure.	186
Silicone Spiral Wrap	188
LG-350-AC Drop Access Sealed Fiber Optic Splice Closure.	189
LG-350XL Sealed Fiber Optic Splice Closure	191
LightGuard Sealed Splice Closure Accessories	193
LightLink Fiber Optic Terminal Adapters for Sealed Splice Closures.	196
LightGuard® (LG) Aerial Weathertight Fiber Optic Splice Closures	197
LG-410 Aerial Weathertight Fiber Optic Splice Closure	198
LG-420 Aerial Weathertight Fiber Optic Splice Closure	200
LG-500 Aerial Weathertight Fiber Optic Splice Closure	202
LG-600 Aerial Weathertight Fiber Optic Splice Closure	204
LG-420 FTTx Aerial Weathertight Closure	206
LG-500 FTTx Aerial Weathertight Closure	208
LG-600 FTTx Aerial Weathertight Closure	210
LG-600 FTTx/32 Aerial Weathertight Closure	212
Interchangeable Grommets for Splice Closures & Enclosures.	214
LightGuard Aerial Splice Closure Accessories	216
LightLink Fiber Optic Splice Trays	218
LightLink Splitter Trays	226

Fiber Containment Vaults

Switchblade® Fiber Containment Vault NEW	227
-----------------------------------------------------------	-----

Fiber Storage Units

Fiber Storage Units.	229
Fiber Storage Units for ADSS Fiber Optic Cable.	230

Preterminated FTTx Solutions

AFL TITAN RTD® FTTx System	231
AFL TRIDENT® Hardened Drop Cables	233

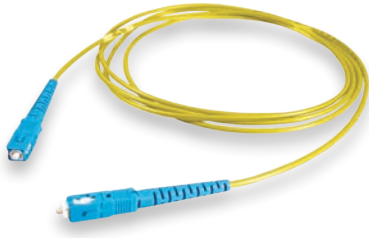

Simplex Cable Assemblies

Simplex cable assemblies are offered with a variety of combinations. Connectors include SC, FC, ST and LC. 3.0 mm, 2.0 mm, 1.6 mm and 900 µm simplex cables in riser and plenum are available.

Features

- 3.0 mm, 2.0 mm, 1.6 mm, and 900 µm cable diameter available
- Riser, Plenum and LSZH rated cables available

Applications

- Building interconnections (campus LAN)
- Trunking lines direct to telecommunications closet
- Fiber patch panels within communications closets
- Links between electronic equipment and fiber patch panels

Cable Components

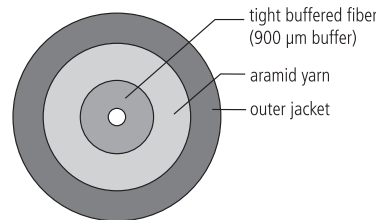

Ordering Information

ASC

Connector End A

Single-mode

ASC = Angle SC
AFC = Angle FC
ALC = Angle LC
USC = Ultra SC
UFC = Ultra FC
UST = Ultra ST
ULC = Ultra LC

Multimode

PSC = SC MM
PFC = FC MM
PLC = LC MM
PST = ST MM

ASC

Connector End B

Single-mode

ASC = Angle SC
AFC = Angle FC
ALC = Angle LC
USC = Ultra SC
UFC = Ultra FC
UST = Ultra ST
ULC = Ultra LC
XXX = No connector

Multimode

PSC = SC MM
PFC = FC MM
PLC = LC MM
PST = ST MM
XXX = No connector

RS

Cable Type

RS = 3.0 mm Riser
PS = 3.0 mm Plenum
KR = 3.0 mm I/O Riser
RT = 2.0 mm Riser
PT = 2.0 mm Plenum
RM = 1.6 mm Riser
PM = 1.6 mm Plenum
JH = 900 µm

001

Fiber Count

001 = 1

Q

Fiber Type

Q = Single-mode*
2 = Multimode 62.5/125 OM1
L = Multimode 50/125 OM3
C = Multimode 50/125 OM4

0010

Cable Length (meters)

0010 = 10 meters
(specify length)

NOTES: * All Single-mode cable assemblies use the ITU G.657.A1 standard.

Qualifications

GOVERNING BODY	STANDARD CODE	COMPONENT
Telcordia	GR-409 GR-326	Cable Connectors
RoHS	Compliant	Cable
ITU	G.652.D, G.657.A1	Single-mode optical fiber only

Contact AFL for further details.

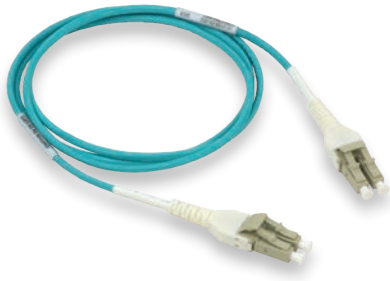

Duplex Cable Assemblies

Zipcord cables are used to meet the requirements for two-fiber cable assemblies, utilizing SC, FC, ST and LC connectors.

Features

- Flexible, 2-fiber design
- Riser, Plenum and LSZH* rated cables available (*contact AFL)

Applications

- Private networks
- Data centers
- High-density applications
- Interconnect and cross-connect
- Premise installations

Cable Components

Zipcord

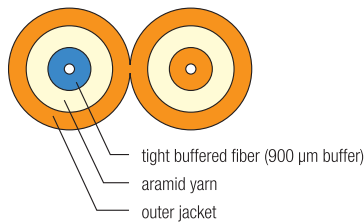

Qualifications

GOVERNING BODY	STANDARD CODE	COMPONENT
Telcordia	GR-409 GR-326	Cable Connectors
RoHS	Compliant	Cable
ITU	G.652.D, G.657.A1	Single-mode optical fiber only

Contact AFL for further details.

Ordering Information

UST	UST	RZ	002	Q	0010
Connector End A	Connector End B	Cable Type	Fiber Count	Fiber Type	Cable Length (meters)
Single-mode AFC = Angle FC UFC = Ultra FC }* UST = Ultra ST ADL = Angled LC Duplex ASF = Angled SC Duplex USF = Ultra SC Duplex UDL = Ultra LC Duplex Multimode PFC = FC MM }* PST = ST MM }* PSF = SC Duplex MM PDL = LC Duplex MM	Single-mode AFC = Angle FC UFC = Ultra FC }* UST = Ultra ST ADL = Angled LC Duplex ASF = Angled SC Duplex USF = Ultra SC Duplex UDL = Ultra LC Duplex XXX = No connector Multimode PFC = FC MM }* PST = ST MM }* PSF = SC Duplex MM PDL = LC Duplex MM XXX = No connector	Zipcord RZ = 3.0 mm Riser PZ = 3.0 mm Plenum R20Z = 2.0 mm Riser P20Z = 2.0 mm Plenum R16Z = 1.6 mm Riser P16Z = 1.6 mm Plenum	002 = 2	Q = Single-mode** 2 = Multimode 62.5/125 OM1 L = Multimode 50/125 OM3 C = Multimode 50/125 OM4	XXXX (specify length) 0010 = 10 meters

NOTES:

1. Refer to Connector Specifications page.
- * Single connector options, quantity two per end. Duplex connectors are assembled with removable clip.
 - ** All Single-mode cable assemblies use the ITU G.652.D/G.657.A1 standard.
 - *** LC Connectors available on 2.0 mm Zipcord cable.

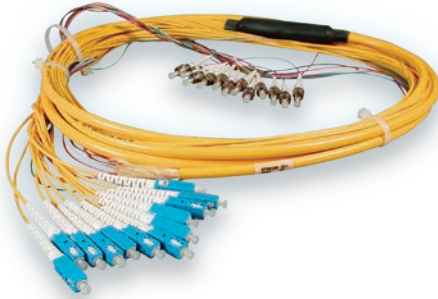

Multi-Fiber Cable Assemblies

Multi-fiber cable assemblies provide safe and cost effective installation for many applications. These assemblies help eliminate labor-intensive field termination, yet guarantee reliable performance. These assemblies feature a unified construction for easy fiber identification and rapid installation.

Features

- 4-144 fibers with aramid yarn reinforcement for rugged protection
- Available with 900 μm tight buffered fibers or sub-unitized design with twelve 250 μm fibers per tube
- Highly flexible for ease of routing
- Riser, Plenum and LSZH rated cables available
- Pre-installed pulling eye kits available on certain products

Applications

- Headend termination to a fiber "backbone"
- Termination of fiber rack systems
- Multi-floor deployment where select fibers are used at each floor
- Intra-building "backbones"
- Data center systems

Specifications

PARAMETER	SINGLE-MODE ASSEMBLIES				MULTIMODE ASSEMBLIES	
	LC		SC		LC	SC
	ULTRA	ANGLED	ULTRA	ANGLED		
Insertion Loss (Typical dB)***	0.15	0.15	0.15	0.15	0.15	0.15
Insertion Loss (Maximum dB)	0.3	0.3	0.3	0.3	0.5	0.5
Return Loss (Typical dB)***	-60	-70	-60	-70	-35	-35
Return Loss (Minimum dB)	-55	-65	-55	-65	-30	-30

*** Typical values based on equal quality connectors.

continued
→

Multi-Fiber Cable Assemblies

Ordering Information

ASC	ASC	RC	012	Q	0010	NN
Connector End A	Connector End B	Cable Type	Fiber Count	Fiber Type	Cable Length (meters)	Leg Diameter
Single-mode ASC = Angle SC AFC = Angle FC USC = Ultra SC UFC = Ultra FC UST = Ultra ST ULC = Ultra LC UDL = Ultra LC Duplex Multimode PSC = SC MM PFC = FC MM PLC = LC MM PST = ST MM PDL = LC Duplex MM* PSF = SC Duplex MM*	Single-mode ASC = Angle SC AFC = Angle FC USC = Ultra SC UFC = Ultra FC UST = Ultra ST ULC = Ultra LC XXX = No connector Multimode PSC = SC MM PFC = FC MM PLC = LC MM PST = ST MM XXX = No connector	RC = Riser (CPC) PC = Plenum (CPC) PL = Plenum MicroCore®	004 = 4 006 = 6 012 = 12 024 = 24 036 = 36 048 = 48 072 = 72 096 = 96 144 = 144	Q = Single-mode ITU G.652D/ G.657.A1 2 = Multimode 62.5/125 μm OM1 L = Multimode 50/125 μm OM3 C = Multimode 50/125 μm OM4	XXXX (specify length) 0010 = 10 meters Leg Diameter N = 900 μm End A / XXX End B NN = 900 μm End A and B F = Furcated End A / XXX End B FF = Furcated Ends A and B FN = Furcated Ends A / 900 μm End B NF = 900 μm End A / Furcated Ends B	

NOTES:

1. Refer to Connector Specifications page.
2. Duplex SC and LC available

Qualifications

GOVERNING BODY	STANDARD CODE	COMPONENT
EIA/TIA	568-A	Cable
Telcordia	GR-409-CORE GR-326	Cable Connectors
RoHS	Compliant	Cable

Temperature Specifications

Temperature Range	-40°C to +85°C
-------------------	----------------

Contact AFL for further details.



MPO Cable Assemblies



MPO Fanout Cable Assemblies

MPO Cable Assemblies

MPO cable assemblies provide a high performance plug-and-play solution for premise installations where space is a premium. Used to interconnect panels or cassettes, the small diameter MicroCore® cable construction reduces the required pathway space and provides a flexible outer jacket in both single-mode and multimode configurations. Multiple breakout options are also available including LC, SC, ST, or FC single fiber connectors.

Features

- High density, plug and play fiber optic interconnects
- Pre-terminated cable assemblies eliminate field termination time and guarantee optical performance
- Available with a wide variety of cable and connector options
- Standard and low loss connectors
- Single-mode and laser-optimized multimode fiber available
- Pulling eye option available upon request

Applications

- Data center systems wiring
- MPO-MPO or MPO-Fanouts
- Headend termination to a fiber "backbone"
- Termination of fiber rack systems
- Multi-floor deployment
- Intra-building "backbones"

Specifications

PARAMETER	SINGLE-MODE ASSEMBLIES					MULTIMODE ASSEMBLIES		
	LC		SC		MPO	LC	SC	MPO (LOW LOSS)
	ULTRA	ANGLED	ULTRA	ANGLED	ANGLED			
Insertion Loss (Typical dB)***	0.15	0.15	0.15	0.15	0.35	0.15	0.15	0.15
Insertion Loss (Maximum dB)	0.3	0.3	0.3	0.3	0.75	0.5	0.5	0.2
Return Loss (Typical dB)***	-60	-70	-60	-70	-65	-35	-35	-30
Return Loss (Minimum dB)	-55	-65	-55	-65	-55	-30	-30	-20
Operation Temperature	0°C to 70°C							
Durability Cycles	500	500	500	500	200	500	500	200

*** Typical values based on equal quality connectors.

continued
→

MPO Cable Assemblies

Ordering Information

MPO-MPO Assemblies

(Female MPOs on both ends – no pins)

(Polarity: Key Up/Key Up, Straight Through)

FIBER COUNT	FIBER TYPE	PULLING EYE	AFL NO.
12	Single-mode, Single Jacket	No	CS017463-XXXX
12	Single-mode	No	CS009980-XXXX
12	Single-mode	Yes	CS009981-XXXX
24	Single-mode	No	CS009984-XXXX
24	Single-mode	Yes	CS009985-XXXX
72	Single-mode	No	CS009996-XXXX
72	Single-mode	Yes	CS009997-XXXX
12	50 µm 10gig 300 (OM3), Single Jacket	No	CS003695-XXXX
12	50 µm 10gig 300 (OM3)	No	CS010649-XXXX
12	50 µm 10gig 300 (OM3)	Yes	CS010650-XXXX
24	50 µm 10gig 300 (OM3)	No	CS003700-XXXX
24	50 µm 10gig 300 (OM3)	Yes	CS009912-XXXX
72	50 µm 10gig 300 (OM3)	No	CS003720-XXXX
72	50 µm 10gig 300 (OM3)	Yes	CS010016-XXXX
12	50 µm 10gig 550 (OM4), Single Jacket	No	CS013364-XXXX
12	50 µm 10gig 550 (OM4)	No	CS008420-XXXX
12	50 µm 10gig 550 (OM4)	Yes	CS010165-XXXX
24	50 µm 10gig 550 (OM4)	No	CS010100-XXXX
24	50 µm 10gig 550 (OM4)	Yes	CS010066-XXXX
72	50 µm 10gig 550 (OM4)	No	CS010101-XXXX
72	50 µm 10gig 550 (OM4)	Yes	CS010067-XXXX

NOTE: XXXX is length in meters.

Contact AFL Customer Service for additional polarity schemes available.

Qualifications

GOVERNING BODY	STANDARD CODE	COMPONENT
Telcordia	GR-326/GR-1435 GR-409-CORE	Connectors Cable
EIA/TIA	568-A	Cable

Contact AFL for further details.

MPO Fanout Assemblies

(Male MPOs — Duplex Connectors)

FIBER COUNT	FIBER TYPE	PULLING EYE	AFL NO.	
			MALE MPO-LC DUPLEX	MALE MPO-SC DUPLEX
12	Single-mode	No	CS009521-XXXX	CS010020-XXXX
12	Single-mode	Yes	CS0010017-XXXX	CS010021-XXXX
24	Single-mode	No	CS003796-XXXX	CS010022-XXXX
24	Single-mode	Yes	CS010018-XXXX	CS010023-XXXX
72	Single-mode	No	CS003811-XXXX	CS010024-XXXX
72	Single-mode	Yes	CS010019-XXXX	CS010025-XXXX
12	50 µm 10gig 300 (OM3)	No	CS011510-XXXX	CS010030-XXXX
12	50 µm 10gig 300 (OM3)	Yes	CS010027-XXXX	CS010031-XXXX
24	50 µm 10gig 300 (OM3)	No	CS003795-XXXX	CS010032-XXXX
24	50 µm 10gig 300 (OM3)	Yes	CS010028-XXXX	CS010033-XXXX
72	50 µm 10gig 300 (OM3)	No	CS003810-XXXX	CS010034-XXXX
72	50 µm 10gig 300 (OM3)	Yes	CS010029-XXXX	CS010035-XXXX
12	50 µm 10gig 550 (OM4)	No	CS009519-XXXX	CS010073-XXXX
12	50 µm 10gig 550 (OM4)	Yes	CS010068-XXXX	CS010074-XXXX
24	50 µm 10gig 550 (OM4)	No	CS010069-XXXX	CS010075-XXXX
24	50 µm 10gig 550 (OM4)	Yes	CS010070-XXXX	CS010076-XXXX
72	50 µm 10gig 550 (OM4)	No	CS010071-XXXX	CS010077-XXXX
72	50 µm 10gig 550 (OM4)	Yes	CS010072-XXXX	CS010078-XXXX

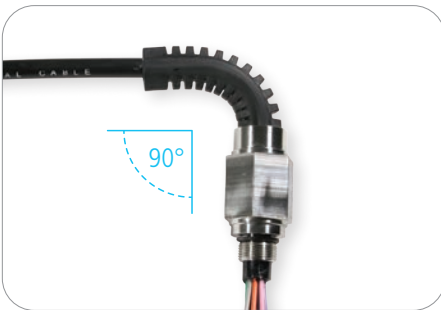
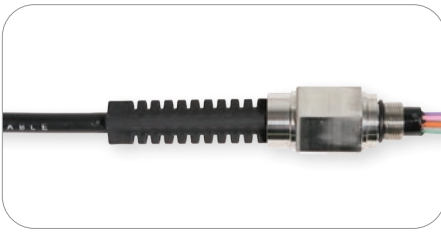

NodeFLEX® Cable Assembly

The AFL NodeFLEX cable assemblies are used to link the Optical Distribution Network (ODN) to Hybrid Fiber-Coaxial (HFC) Nodes. The NodeFLEX fitting includes a flexible boot with integrated steel wires that allow installers to flex the boot to an angle up to 90° and hold that position for applications where 90° entry is required. This eliminates the need for separate straight and 90° node cables, thus reducing inventory and ordering complexity. The SCTE 5/8-24 UNEF threaded fitting of the assembly provides a water-tight seal for up to 3 meters of static waterhead. The fitting materials are machined from stainless steel to ensure long life in the outside plant environment.

Specifications

PARAMETER	VALUE
Operating Temperature °F (°C)	-40 to 158 (-40 to 70)
Cable Retention lbf (N)	100 (445)
Fiber Count	2-24
Maximum Insertion Loss (dB)	0.30
Return Loss (dB)	≥55 (UPC), ≥65 (APC)
Fitting Material	Stainless Steel
Fitting Threads	5/8-24 UNEF
Hex Nut Size (in.)	1
Cable Diameter, Armored, 2-12 Fiber in. (mm)	0.32 (8.2)
Cable Diameter, Dielectric, 2-24 Fiber in. (mm)	0.26 (6.7)
Cable Diameter, Armored, 24 Fiber in. (mm)	0.33 (8.4)

Features

- An assortment of industry standard connector styles are available such as SC/APC, SC/UPC, FC/APC, FC/UPC and LC/UPC
- Available from 2 to 24 fibers
- Available with 900 μm, 1.6 mm or 2.0 mm color-coded furcation at various lengths to accommodate all applications
- Dielectric or armored outside plant cables available
- IP68 rated up to 3 meters of water head
- Unbody design allows for installation into the node without twisting the cable
- Stainless steel fitting with UV-stabilized rubber boot

Cable Components

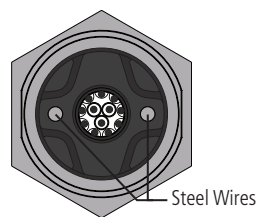

Flexible Boot

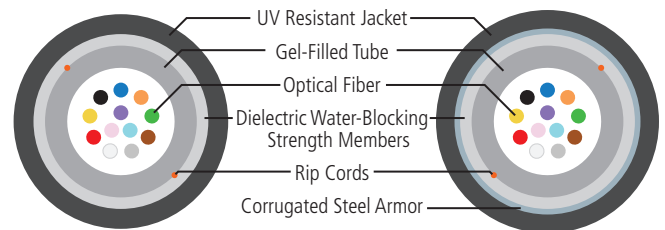

Dielectric Cable

Armored Cable

Ordering Information

ASC	XXX	NC	012	Q	0010FT	F2041
Connector End A	Connector End B	Cable Type	Fiber Count	Fiber Type	Cable Length (meters)	Leg Diameter
ASC = Angled SC AFC = Angled FC USC = Ultra SC UFC = Ultra FC UST = Ultra ST ULC = Ultra LC ALC = Angled LC	XXX = No connector	NC = Dielectric Round Drop AN = Armored Round Drop	002 = 2 004 = 4 006 = 6 008 = 8 012 = 12 024 = 24	Q = Single-mode	XXXX (specify length) 0010 = 10 meters 0010FT = 10 feet	N = 900 μm End A 41 inches length F1624 = 1.6 mm End A 24 inches length F1636 = 1.6 mm End A 36 inches length F1641 = 1.6 mm End A 41 inches length (F16XX required for 24 fiber) F2041 = 2.0 mm End A 41 inches length (Default 41 inches length)



Loose Tube and Riser Rated Indoor/Outdoor Loose Tube Cable Assemblies

High fiber count Loose Tube and Riser Rated Indoor/Outdoor Loose Tube Cable assemblies provide a safe and proven method of utilizing preterminated connector technology for outside plant applications. These assemblies help control cost by eliminating labor-intensive field termination and provide the same factory terminated reliability the industry has trusted for many years. Cable assemblies are available in Indoor/Outdoor Loose Tube, suitable for use in both indoor and outdoor applications.

Applications

- Outdoor Cabinets
- External-Building Runs
- Vaults
- CEVs
- Duct and lashed applications

Features

- Fiber counts from 6 to 144 fibers (up to 432 for Loose Tube)
- Available with ST, SC, FC, and LC connectors single-mode
- Pigtail assemblies, standard configuration (nonstandard configurations available)
- ST, SC, FC and LC connectors available in both single-mode and multimode
- Pre-installed pulling eye kits available
- 1 meter standard breakout length
- 2.4 mm standard furcation for SC, FC, ST
- 1.6 mm standard furcation for LC
- UV resistant outer jacket
- S-Z stranded for easy mid-span access
- Gel-filled loose buffer tubes (RL), Gel-filled Loose Tube (LT)

Cable Components

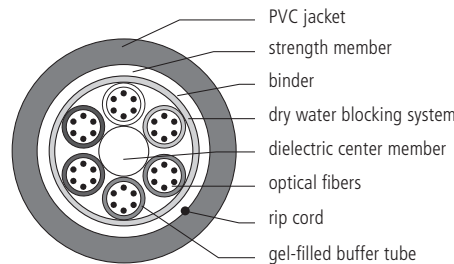

Riser Rated Indoor/Outdoor Loose Tube

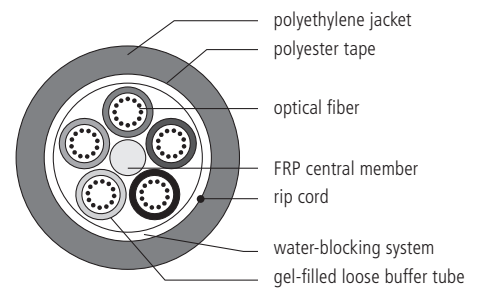

Loose Tube

Dimensions

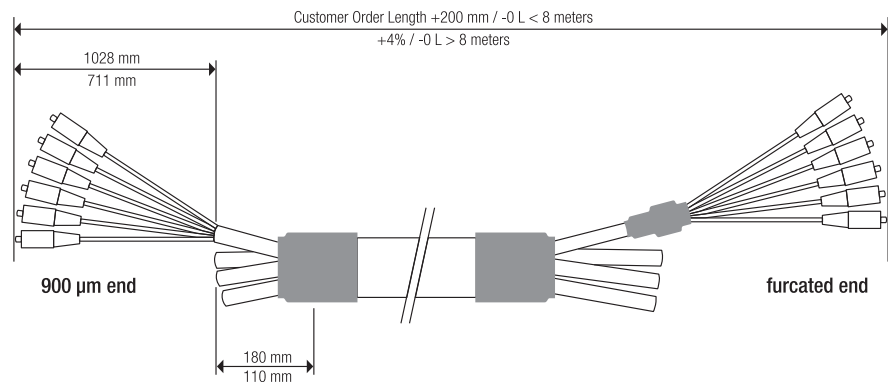

continued
→

Loose Tube and Riser Rated Indoor/Outdoor Loose Tube Cable Assemblies

Ordering Information

ASC	ASC	LT	024	Q	0010	NN
Connector End A	Connector End B	Cable Type	Fiber Count	Fiber Type	Cable Length (meters)	Leg Diameter
Single-mode ASC = Angle SC AFC = Angle FC USC = Ultra SC UFC = Ultra FC UST = Ultra ST ULC = Ultra LC	Single-mode ASC = Angle SC AFC = Angle FC USC = Ultra SC UFC = Ultra FC UST = Ultra ST ULC = Ultra LC XXX = No connector	LT= Loose Tube RL=Riser Rated Indoor/Outdoor Loose Tube	006 = 6 012 = 12 024 = 24 036 = 36 048 = 48 072 = 72 096 = 96 144 = 144	Q = Single-mode X = Single-mode ITU-T G.657A BIF	XXXX (specify length) 0010 = 10 meters	 N = 900 μm End A / XXX End B NN = 900 μm End A and B F = Furcated End A / XXX End B FF = Furcated Ends A and B FN = Furcated Ends A / 900 μm End B NF = 900 μm End A / Furcated Ends B

Lengths Available

Cable lengths are dependent on fiber cable type and count.
 Consult customer service for maximum lengths available.

Qualifications

GOVERNING BODY	STANDARD CODE	COMPONENT
Telcordia	GR-326 GR-20-CORE	Connectors Cable
EIA/TIA		Loose Tube Cable
UL	1666 OFNR	Riser Rated I/O Loose Tube Cable
REA/RUS	PE-90	Loose Tube Cable

Temperature Range

	Riser Rated I/O Loose Tube	Loose Tube
Operating	-40°C to +70°C	-40°C to +70°C
Storage	-40°C to +75°C	-40°C to +75°C
Installation	0°C to +70°C	-30°C to +70°C

Contact AFL for further details.

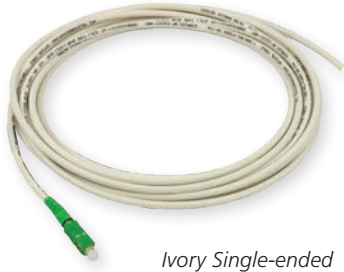

Ivory Single-ended



Black Double-ended

MDU Drop Cable Assemblies

AFL single-mode SC Angled Indoor and Indoor/Outdoor MDU Drop Assemblies are designed to meet stringent performance requirements of the latest FTTH (Fiber-to-the-Home) applications. Bend-insensitive fiber reduces macrobending attenuation when routing the drops in tight environments and the SC angled connector guarantees the high performance return loss required of video signals. Availability in both compact 3.0 mm and rugged 4.8 mm varieties allows for multiple installation scenarios. Assemblies are tested and qualified to Telcordia GR-326, Issue 3 requirements and meet all EIA/TIA 455-3 (FOCIS 3) interface standards for SC connectors.

Features

Connectors:

- Ceramic ferrule utilized for precision fiber alignment
- Keyed push-pull latching mechanism
- Connector housings are color-coded (Green) for APC identification and -65 dB return loss

Applications

- Multi-Dwelling Unit (MDU) drop cables for FTTH systems
- CATV Video systems
- LAN Networks

Cable Components

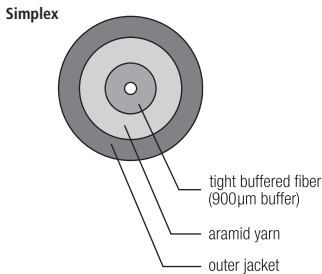

Qualifications

GOVERNING BODY	STANDARD CODE
Telcordia	GR-326 (Issue 3)
EIA/TIA	455-3 (FOCIS 3)

Temperature Specifications

Installation	-20°C to +70°C
Operating	-40°C to +70°C
Storage	-40°C to +70°C

Specifications

INSERTION LOSS		RETURN LOSS		FIBER TYPE	MAX. ATTENUATION		NOMINAL DIAMETER		TENSION		BENDING RADIUS	
MAX.	TYP.	MAX.	TYP.		1310 NM	1550 NM	INCHES (MM)		LBS (N)		INCHES (MM)	
0.25 dB	0.15 dB	-65 dB	-68 dB	Bend Insensitive G.657.B3	0.5 dB/km	0.5 dB/km	0.11 in. (3.0 mm)	0.19 in. (4.8 mm)	100 lbs. (450 N)	30 lbs. (150 N)	0.2 in. (5 mm)	0.2 in. (5 mm)

Ordering Information

ASC		KR	001	X	0010	FT	BLACK
Connector End A	Connector End B	Cable Type	Fiber Count	Fiber Type	Cable Length	Unit of Measure	Color
ASC = Angle SC USC = Ultra SC	ASC = Angle SC USC = Ultra SC Blank = Single Ended	K48R = Indoor/Outdoor 4.8 mm KR = Indoor/Outdoor 3.0 mm	001 = 1	X = Bend Insensitive G.657.B3		Blank = Meters FT = Feet	Ivory Black



Fanout Kits

Fanout kits route 250 μm fibers into 900 μm buffer tubes ready for termination. These kits require no special tools and accommodate input cables from 2.0-3.8 mm in diameter. Fanout kits feature a clear, removable cover which is VFL-compatible and does not require epoxy. Color-coded 900 μm buffer tubes allow for easy identification of individual fiber channels.

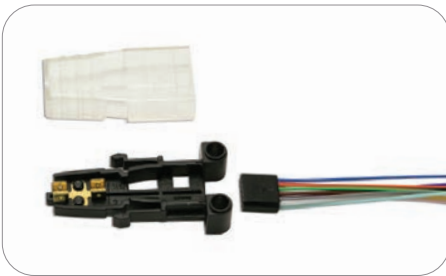

Features

- Accepts 2.0-3.8 mm input cable
- Epoxy-free installation
- Clear, removable cover works with Visual Fault Locators (VFL)
- Protects sensitive 250 μm fibers
- Compatible with FUSEConnect® and FASTConnect® field-installable connectors

Applications

- Routing 250 μm fibers into 900 μm buffer tubes for termination

Specifications

PARAMETER	VALUE
Fiber Count	12
Environment	Indoor
Input Cable Size	2.0 - 3.8 mm
Length	1 meter or 3 meter







Temperature Specifications

TEMPERATURE RANGE	
Operation	-0°C to 70°C

Ordering Information

AFL NO.	DESCRIPTION
FAN1-9-012-A-01	Fanout kit, 1 position base, 900 μm , 12 tubes, A, 1M
FAN1-9-012-A-03	Fanout kit, 1 position base, 900 μm , 12 tubes, A, 3M

Connector Specifications

PARAMETER	CONNECTOR													
	SC		FC		ST		LC		MTP		MT-RJ		MU	
Single-mode Assemblies														
Image														
	Ultra	Angle	Ultra	Angle	Ultra	Angle	Ultra	Angle	Flat	Angle	Ultra	Angle	Ultra	Angle
Insertion loss (dB)														
Maximum	0.3	0.3	0.3	0.3	0.3	—	0.3	0.3	—	0.75	0.5	—	0.3	—
Typical	0.15	0.2	0.25	0.2	0.15	—	0.15	0.15	—	0.35	0.25	—	0.2	—
Return Loss (dB)														
Minimum	-55 dB	-65 dB	-55 dB	-65 dB	-55 dB	—	-55 dB	-65 dB	—	-55 dB	-35 dB	—	-55 dB	—
Temp Range (°C)	-40 to +85		-40 to +85		-40 to +85		-40 to +85		-40 to +75		-40 to +75		-40 to +85	
Durability Cycles	500		500		500		500		200		200		500	

Multimode Assemblies														
Insertion loss (dB)														
Maximum	0.5	—	0.5	—	0.5	—	0.3	—	0.75	—	0.5	—	0.5	—
Typical	0.25	—	0.25	—	0.25	—	0.25	—	0.35	—	0.25	—	0.25	—
Return Loss (dB)														
Minimum	-30 dB	—	-30 dB	—	-30 dB	—	-30 dB	—	-20 dB	—	-20 dB	—	-30 dB	—
Temp Range (°C)	-40 to +85		-40 to +85		-40 to +85		-40 to +85		-40 to +75		-40 to +75		-40 to +85	
Durability Cycles	500		500		500		500		200		200		500	
Cable Options	Simplex/Duplex 900 µm 1.6 mm 2.0 mm 2.4 mm 3.0 mm	Simplex/Duplex 900 µm 1.6 mm 2.0 mm 2.4 mm 3.0 mm	Simplex/Duplex 900 µm 1.6 mm 2.0 mm 2.4 mm 3.0 mm	Simplex/Duplex 900 µm 1.6 mm 2.0 mm 2.4 mm 3.0 mm	Simplex/Duplex 900 µm 1.6 mm 2.0 mm	Bare Ribbon Jacketed Ribbon 8-12 Fiber Count	Bare Ribbon Jacketed Ribbon Dual Link Zipcord	900 µm 2.0 mm						
Applications	Telephony CATV/Broadband Telco Backplanes LAN/WAN	Telephony CATV/Broadband Telco Backplanes LAN/WAN	Telephony CATV/Broadband Telco Backplanes LAN/WAN	Telephony CATV/Broadband Telco Backplanes LAN/WAN	Telephony CATV/Broadband Telco Backplanes LAN/WAN	Telephony CATV/Broadband Telco Backplanes LAN/WAN	Telephony CATV/Broadband Telco Backplanes LAN/WAN	Telephony CATV/Broadband Telco Backplanes LAN/WAN						



Buildout Attenuators

Buildout attenuators provide superior performance for all single-mode in-line attenuation requirements. Standard attenuation values are 5, 10, 15, and 20 dB, available in SC, FC, ST, and LC connector styles. Using no air gap, filters, or light path discontinuities, attenuation is achieved by controlled absorption of light energy. This results in a polarization insensitive device with high power handling capability, environmentally stable, and exceptionally responsive, across a wide bandpass range.

Features

- SC, FC, ST, and LC connector styles (Ultra & Angled Polish)
- Long-term reliability
- Low ripple, wavelength independent attenuation
- Certified to >125 mW continuous power handling capability with no performance degradation
- Polarization insensitive

Application

- Broadband Network
- Fiber in the Loop
- Local Area Networks (LAN)
- Long Haul Telecommunications (CLEC, CAPS)
- Network Testing
- Passive Optical Networks
- Telco

Specifications

PARAMETER	VALUE
Standard Attenuation Values	5, 10, 15 and 20 dB
Attenuation Tolerance	Standard at 10%
Vibration resistance	<0.1X attenuation value
Operating Temperature Range:	-40°C to +75°C
Storage Temperature Range:	-40°C to +85°C

Ordering Information

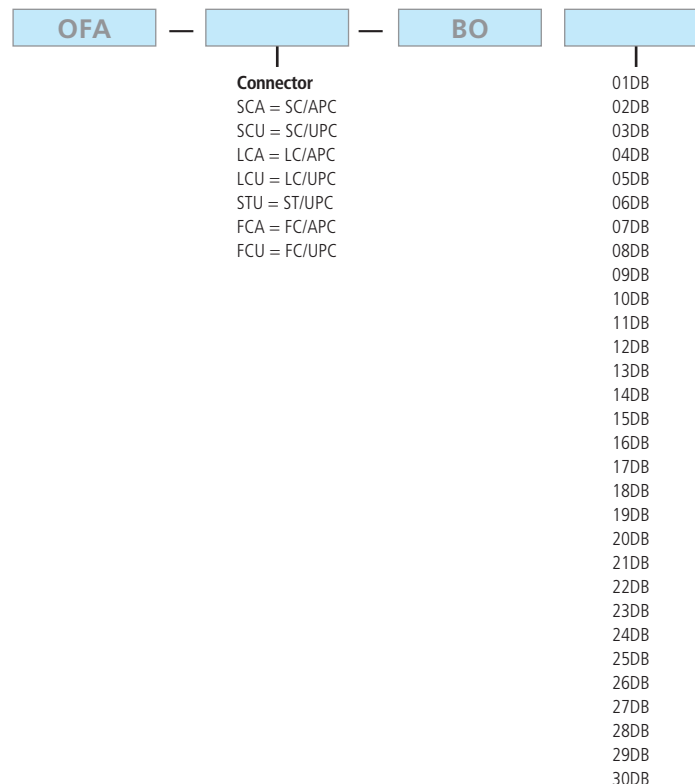

Optical Adapters

SC Adapters

SC adapters are used to mate industry standard SC connectors. Adapters are available with metal and ceramic alignment sleeves, and are color coded for easy identification. The duplex adapters accept two simplex connectors or one duplex connection. Hybrids are available for special applications.

Type	Mode	Description	Sleeve	Color	AFL No.
SC Simplex Adapters					
SC Simplex	MM	Flangeless	Ceramic	Beige	CS013275
SC Simplex	SM	Flangeless	Ceramic	Blue	CS013274
SC Simplex	SM	Flangeless	Ceramic	Green	CS018945
SC Simplex	MM	Flangeless	Ceramic	Aqua	CS013426
SC Duplex Adapters					
SC Duplex	MM	Flangeless	Ceramic	Beige	CS013277
SC Duplex	SM	Flangeless	Ceramic	Blue	CS017295
SC Duplex	SM	Flangeless	Ceramic	Green	CS017296
SC Duplex	MM	Flangeless	Ceramic	Aqua	CS013279

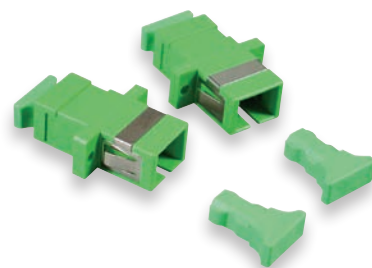

SC Simplex Adapters

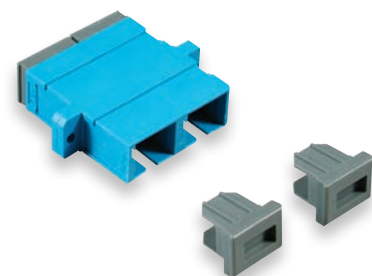

SC Duplex Adapters

FC Adapters

FC adapters connect industry standard FC connectors and are available in Square-Mount, D-Mount and Flange-Mount versions. Our FC adapters feature a metal body for long life and are available with either ceramic or metallic sleeves. The FC D-Mount adapter easily installs into panel mount applications. FC Square-Mount angle polish versions meet the industry standard 2.0 mm key width. An assortment of hybrid configurations is available.

Type	Mode	Description	Sleeve	Color	AFL No.
FC Simplex	SM	D Mount	Ceramic	Metal	CS013316



Qualifications

Governing Body	Standard Code
JIS	C5970
Bellcore	GA326

ST Adapters

ST adapters connect industry standard ST connectors and are available in D-Mount and Flange-Mount versions. ST adapters are available with x or metallic sleeves, feature a metal body for long life, and easily install in panel mount applications.

Type	Mode	Description	Sleeve	Color	AFL No.
ST Simplex	SM/MM	D Mount	Ceramic	Metal	C094994

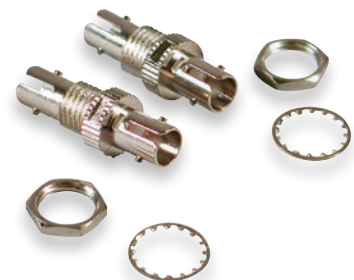

continued
→

Optical Adapters

LC Adapters

LC style adapters are used in high density applications and feature a quick plug in installation. Adapters are available in both simplex and duplex designs and utilize high quality zirconia and phosphorous bronze sleeves. The LC duplex adapter uses the same cutout as the copper RJ-45, resulting in less redesign work when retrofitting existing panels.

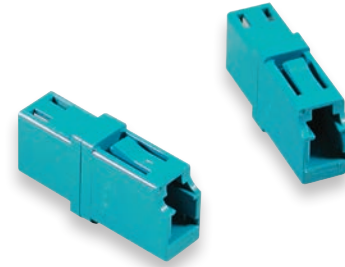

Type	Mode	Insert	Color	AFL No.
LC Simplex Adapters				
LC Simplex	SM	Ceramic	Blue	CS013424
LC Simplex	MM	Ceramic	Beige	CS013423
LC Duplex Adapters				
LC Duplex	SM	Ceramic	Blue	CS013283
LC Duplex	SM	Ceramic	Green	CS013195
LC Duplex	MM	Ceramic	Beige	CS013282
LC Duplex	MM	Ceramic	Aqua	CS013281

MTP Adapters

The MTP adapter connects two industry standard MTP connectors. The compact MTP adapter measures 25 mm x 10 mm and is found in high density applications.



Type	Mode	Description	Sleeve	Color	AFL No.
MTP	SM/MM	Flange Mount	—	Black	C057010
MTP (aligned keyway)	SM/MM	Flange Mount	—	Grey	CS000211

Hybrid Adapters

Simplex female-female hybrid adapter are available to fit specific application needs.

Type	Mode	Description	Sleeve	Color	AFL No.
ST – FC	SM/MM	Flat Mount	Ceramic	Metal	C032980
SC – FC	SM – APC	FLAT MOUNT	CERAMIC	METAL	C130082
SC – FC	SM/MM	Square Mount	Ceramic	Metal	C002453
SC – FC	SM/MM	Flat Mount	Ceramic	Metal	C033030
SC – ST	SM/MM	Flat Mount	Ceramic	Blue	C024392
SC – ST	SM/MM	Flat Mount	Ceramic	Metal	C038733

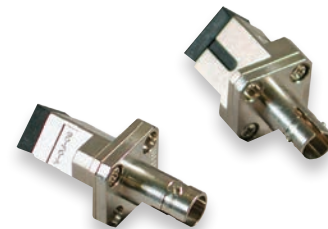

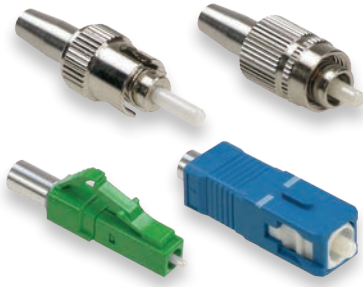

Optical Terminators

Optical terminators are used to terminate unused connector ports in fiber optic systems so that unwanted reflections are not introduced back into the system. All AFL optical terminators feature zirconia ferrules for long life and durability.

Specifications

PARAMETER	VALUE
Reflectance	<-55 dB (ultra polish)
Reflectance	<-60 dB (angle polish)
Operating Temperature	-40°C to +85°C
Operating Wavelength	1260 nm to 1580 nm

Ordering Information

DESCRIPTION	AFL NO.
SC/UP Terminator	C067393
SC/AP Terminator	C148828
FC/UP Terminator	C067407
FC/AP Terminator	C082562
ST/UP Terminator	C167083
LC/UP Terminator	CS000637
LC/AP Terminator	CS000638

SpliceConnect with Tool Kit

AFL's SpliceConnect is a mechanical splice that provides an inexpensive, quick alternative to mating fibers. Using V-groove technology, this splice maintains physical contact between the fibers. An assembly tool is used to ensure the fibers are mated correctly, resulting in <math><0.1\text{ dB}</math> insertion loss (typical for single-mode). The SpliceConnect secures both fiber and coating independently with the U-shaped sleeve, enhancing the strength against fiber twist.



Features

- Quick splicing time
- Minimal tools
- 250 μm and/or 900 μm fiber capabilities
- Both fiber and coating are secured independently

Applications

- Restoration
- Premise environments
- Fiber-to-the-Subscriber (FTTx) applications

Dimensions and Structure

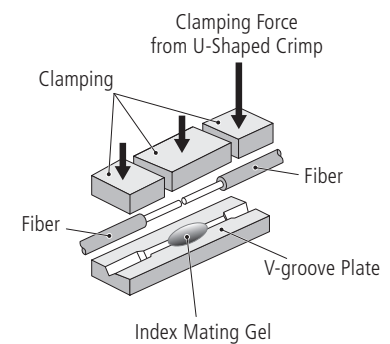
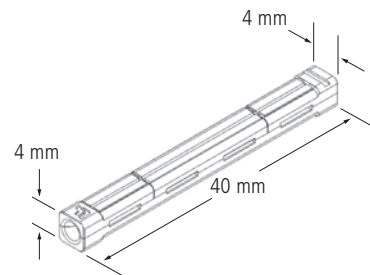

Ordering Information

DESCRIPTION	AFL NO.
SpliceConnect Mechanical Splices (Bag of 6)	CS004154
SpliceConnect Mechanical Splice Tool Kit <i>Kit Includes:</i>	CS004162
SpliceConnect Mechanical Splicing Tool	CS004155
Fiber Holder, 250 μm x2	CS004442
Fiber Holder, 900 μm x2	CS004443
Instruction Manual	CS004159
Carrying Case	CS004161
Template, Strip/Cleave Length	CS004573
SpliceConnect Mechanical Splicing Tool	CS004155
Fiber Holder, 250 μm	CS004442
Fiber Holder, 900 μm	CS004443



Optical Coupler Modules

The optical coupler module offers management of optical power and wavelength, packaged in the LGX® design. Each module is comprised of Telcordia®-compliant PLC or concatenated fused biconic components. Once assembled and terminated, the module is fully tested for environmental, mechanical, and optical integrity.

Features

- Telcordia GR-1209 & GR-1221 compliant
- Telcordia GR-326 compliant connectors and adapters
- Telcordia GR-20 compliant singlemode optical fiber
- RoHS compliant
- Packaged individually / tamper-proof seal

Applications

- CATV
- Telco
- Wide Area Networks
- Fiber Monitoring Systems
- Military systems

Specifications

PARAMETER	VALUE	
	Single-mode	
	Ultra	Angled
Return Loss (Minimum dB)	> -45	> -50
Directivity	> -55	
Operating Temperature/ Relative Humidity	-40 to +85°C / 90%	
Storage Temperature/ Relative Humidity	-40 to +85°C / 90%	

Ordering Information

I/O PORTS	I/O CONN	AFL NO.	OPTICAL BANDPASS	OUTPUT PORT COUPLING RATIO (PORT)		INSERTION LOSS (IL) PORT 01		INSERTION LOSS (IL) PORT 02	
				01	02	TYP	MAX	TYP	MAX
1 x 2	USC	CM000165	1310 ± 40 nm / 1550 ± 40 nm	50	50	3.3	4.0	3.3	4.0
1 x 2	USC	CM000166	1310 ± 40 nm / 1550 ± 40 nm	40	60	4.3	5.2	2.5	3.3
1 x 2	USC	CM000167	1310 ± 40 nm / 1550 ± 40 nm	30	70	5.5	6.4	1.5	2.4
1 x 2	USC	CM000168	1310 ± 40 nm / 1550 ± 40 nm	20	80	7.3	8.3	1.3	1.8
1 x 2	USC	CM000169	1310 ± 40 nm / 1550 ± 40 nm	10	90	10.3	11.5	0.8	1.1
1 x 2	USC	CM000170	1310 ± 40 nm / 1550 ± 40 nm	5	95	13.3	14.6	0.5	0.8
1 x 2	ASC	CM000171	1310 ± 40 nm / 1550 ± 40 nm	50	50	3.3	4.0	3.3	4.0
1 x 2	ASC	CM000172	1310 ± 40 nm / 1550 ± 40 nm	40	60	4.3	5.2	2.5	3.3
1 x 2	ASC	CM000173	1310 ± 40 nm / 1550 ± 40 nm	30	70	5.5	6.4	1.5	2.4
1 x 2	ASC	CM000174	1310 ± 40 nm / 1550 ± 40 nm	20	80	7.3	8.3	1.3	1.8
1 x 2	ASC	CM000175	1310 ± 40 nm / 1550 ± 40 nm	10	90	10.3	11.5	0.8	1.1
1 x 2	ASC	CM000176	1310 ± 40 nm / 1550 ± 40 nm	5	95	13.3	14.6	0.5	0.8
1 x 2	ULC	CM000315	1310 ± 40 nm / 1550 ± 40 nm	50	50	3.3	4.0	3.3	4.0
1 x 2	ULC	CM000325	1310 ± 40 nm / 1550 ± 40 nm	40	60	4.3	5.2	2.5	3.3
1 x 2	ULC	CM000323	1310 ± 40 nm / 1550 ± 40 nm	30	70	5.5	6.4	1.5	2.4
1 x 2	ULC	CM000321	1310 ± 40 nm / 1550 ± 40 nm	20	80	7.3	8.3	1.3	1.8
1 x 2	ULC	CM000319	1310 ± 40 nm / 1550 ± 40 nm	10	90	10.3	11.5	0.8	1.1
1 x 2	ULC	CM000317	1310 ± 40 nm / 1550 ± 40 nm	5	95	13.3	14.6	0.5	0.8
1 x 2	ALC	CM000310	1310 ± 40 nm / 1550 ± 40 nm	50	50	3.3	4.0	3.3	4.0
1 x 2	ALC	CM000324	1310 ± 40 nm / 1550 ± 40 nm	40	60	4.3	5.2	2.5	3.3
1 x 2	ALC	CM000322	1310 ± 40 nm / 1550 ± 40 nm	30	70	5.5	6.4	1.5	2.4
1 x 2	ALC	CM000320	1310 ± 40 nm / 1550 ± 40 nm	20	80	7.3	8.3	1.3	1.8
1 x 2	ALC	CM000318	1310 ± 40 nm / 1550 ± 40 nm	10	90	10.3	11.5	0.8	1.1
1 x 2	ALC	CM000316	1310 ± 40 nm / 1550 ± 40 nm	5	95	13.3	14.6	0.5	0.8

LGX is a registered trademark of Furukawa Electric North America, Inc.

Telcordia is a registered trademark of Telcordia Technologies, Inc.

Optical Coupler Modules

Ordering Information (cont.)

I/O PORTS	I/O CONN	AFL NO.	OPTICAL BANDPASS	OUTPUT PORT COUPLING RATIO (%) EACH PORT	INSERTION LOSS (dB) EACH PORT	
					TYP	MAX
1 x 3	USC	CM000177	1310 ± 40 nm / 1550 ± 40 nm	33.0	5.1	6.2
1 x 3	ASC	CM000178	1310 ± 40 nm / 1550 ± 40 nm	33.0	5.1	6.2
1 x 3	ULC	CM000326	1310 ± 40 nm / 1550 ± 40 nm	33.0	5.1	6.2
1 x 3	ALC	CM000311	1310 ± 40 nm / 1550 ± 40 nm	33.0	5.1	6.2

I/O PORTS	I/O CONN	AFL NO.	OPTICAL BANDPASS	OUTPUT PORT COUPLING RATIO (%) EACH PORT	INSERTION LOSS (dB) EACH PORT	
					TYP	MAX
1 x 4	USC	CM000179	1310 ± 40 nm / 1550 ± 40 nm	25.0	6.3	7.7
1 x 4	ASC	CM000180	1310 ± 40 nm / 1550 ± 40 nm	25.0	6.3	7.7
1 x 4	ULC	CM000327	1310 ± 40 nm / 1550 ± 40 nm	25.0	6.3	7.7
1 x 4	ALC	CM000312	1310 ± 40 nm / 1550 ± 40 nm	25.0	6.3	7.7

I/O PORTS	I/O CONN	AFL NO.	OPTICAL BANDPASS	OUTPUT PORT COUPLING RATIO (%) EACH PORT	INSERTION LOSS (dB) EACH PORT	
					TYP	MAX
1 x 8	USC	CM000181	1260 - 1650 nm	12.5	9.3	11.4
1 x 8	ASC	CM000182	1260 - 1650 nm	12.5	9.3	11.4
1 x 8	ULC	CM000346	1260 - 1650 nm	12.5	9.3	11.4
1 x 8	ALC	CM000347	1260 - 1650 nm	12.5	9.3	11.4

I/O PORTS	I/O CONN	AFL NO.	OPTICAL BANDPASS	OUTPUT PORT COUPLING RATIO (%) EACH PORT	INSERTION LOSS (dB) EACH PORT	
					TYP	MAX
1 x 16	ASC	CM000476	1260 - 1650 nm	6.25	13.1	13.8

I/O PORTS	I/O CONN	AFL NO.	OPTICAL BANDPASS	OUTPUT PORT COUPLING RATIO (%) EACH PORT	INSERTION LOSS (dB) EACH PORT	
					TYP	MAX
1 x 32	ASC	CM000477	1260 - 1650 nm	3.125	16.2	16.8

Insertion loss (IL) includes connector loss and Polarization Dependent Loss (PDL) across operating temperature over the Optical Bandpass.

*** Additional split ratios available upon request.

Qualifications

GOVERNING BODY	STANDARD CODE
RoHS	?
Telcordia	GR-1209, GR-1221, GR-326 and GR-20

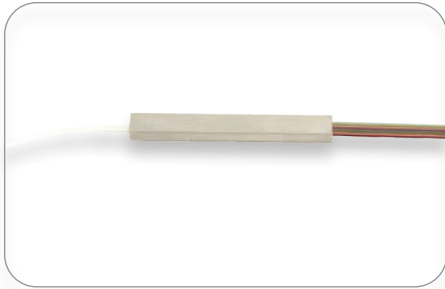

Planar Lightwave Circuit (PLC) Splitters

Planar Lightwave Circuits split optical power evenly over the entire single-mode operating window (1260-1650 nm). Split counts are available from 1x4 up to 2x32 and input/output fibers can be supplied with or without connectors.

Features

- Full spectrum (1260-1650 nm) operation
- Even split ratio over entire bandwidth
- Compact design
- Low PDL and temperature sensitivity
- High directivity

Applications

- Telecommunications
- CATV
- LAN
- Monitoring of networks

Specifications

PARAMETER	UNITS	VALUE			
		1x4	1x8	1x16	1x32
Operating Wavelength	nm	1260-1650			
Insertion Loss (IL)*	dB	≤ 7.4	≤ 10.8	≤ 14.3	≤ 17.4
Uniformity	dB	≤ 0.8	≤ 1.0	≤ 1.3	≤ 1.5
Return Loss (RL)	dB	≥ 50			
Directivity	dB	≥ 55			
PDL	dB	≤ 0.2		≤ 0.3	
Operating Temperature	°C	-40 to +85			
Storage Temperature	°C	-40 to +85			

* Without connectors. With connectors, add 0.3 dB (typical).

Packaging Information

PARAMETER	STANDARD				SMALL FORM FACTOR			
	1x4	1x8	1x16	1x32	1x4	1x8	1x16	1x32
Fiber Type	G.657.A1				G.657.A1			
Input/output Fiber	2 mm or 3 mm Loose Tube				900 μm Loose Tube			
Loose Tube Color	Yellow				White			
Loose Tube Material	PVC				Hytrel			
Housing Material	PVC				Stainless Steel			
Length (mm)	100	100	120	141	60	60	60	80
Width (mm)	80	80	80	114	7	7	12	20
Height (mm)	10	10	18	18	4	4	4	6

Ordering Information

PLC	1x4	9	1M	ULC
	Ports	Cable Diameter	Length	Output Connector
	1x2	9 = 900 μm	1M	ULC = LC/UPC
	1x4	2 = 2 mm	2M	ALC = LC/APC
	1x8	3 = 3 mm	3M	USC = SC/UPC
	1x16		4M	ASC = SC/APC
	1x32		5M	UFC = FC/UPC
	2x2			AFC = FC/APC
	2x4			XXX = No Connector
	2x8			
	2x16			
	2x32			

Qualifications

GOVERNING BODY	STANDARD CODE
Telcordia	GR-1209 and GR-1221



Wideband Couplers

The dual window Wideband Couplers (WBC) split or couple optical power in two wavelength regions while maintaining a very broad operating bandwidth. Split and coupling ratios are available from 5% to 50%. WBCs are widely considered one of the most cost-effective solutions to optical power management. The WBC is an all-fiber device, based on AFL's fused biconic technology, and is designed and manufactured to meet military and Telcordia® requirements.

Features

- Dual window wideband operation
- Low insertion loss over entire bandwidth and temperature (typical IL change $< \pm 0.1$ dB)
- Ultra-low PDL and temperature sensitivity
- High directivity
- Compact design
- Environmentally stable, over 10 years of proven field reliability

Applications

- Telecommunications
- CATV
- LAN
- Monitoring of Networks

Specifications

STANDARD AND PREMIUM GRADES

PARAMETER	VALUE
Operating Wavelength	1310 nm + 50 and 1550 nm + 50
Return Loss	55 dB
Directivity	55 dB
Package Dimension	3.2 mm (dia.) x 55 mm (L)
Operating Temperature	-40° to +85°C
Storage Temperature	-40° to +85°C

Ordering Information

SINGLE-MODE PREMIUM GRADE SPECIFICATIONS (MAX. INSERTION LOSS AND MAX. PDL)

RATIO	SPECIFICATIONS (DB)		AFL NO.
	PRIMARY/SECONDARY PORT	PDL (DB)	
50/50	3.6/3.6	0.15	C198364-P
55/45	3.2/4.1	0.15	C198358-P
60/40	2.7/4.7	0.14	C198353-P
65/35	2.3/5.3	0.14	C198349-P
67/33	2.2/5.7	0.14	C198904-P
70/30	2.0/6.0	0.13	C198346-P
75/25	1.8/6.8	0.13	C198340-P
80/20	1.3/7.8	0.10	C198335-P
85/15	1.0/9.2	0.10	C198331-P
90/10	0.8/11.2	0.10	C198328-P
95/5	0.5/14.4	0.10	C198322-P

Qualifications

GOVERNING BODY	STANDARD CODE
Telcordia	GR-1209 and GR-1221

Telcordia is a registered trademark of Telcordia Technologies, Inc.



Ruggedized Wideband Couplers

Enhancing AFL's wideband coupler offering are two package styles for ruggedized versions of these reliable, standardized couplers – 3 mm and 900 μm furcated pigtail options and a variety of connector styles. All AFL couplers conform to stringent environmental and mechanical standards to provide high reliability in a variety of customer applications.



Features

- Dual window wideband operation
- Low insertion loss
- Low PDL
- High Directivity
- Long term field application
- Environmentally stable

Applications

- Telecommunications
- CATV
- LAN
- Fiber in the Loop
- Network monitoring

Specifications

PARAMETER	VALUE
Operating Wavelength	1310 nm +/- 40 and 1550 nm +/- 40
Return Loss	55 dB
Directivity	55 dB
Operating Temperature	-40° to +85°C
Storage Temperature	-40 to +85°C

Ordering Information

WBC	1x2	50/50	900	ULC	1M	ULC	1M
	Inputs x Outputs	Split Ratio (%/%)	Leg Diameter	Input Connector	Input Length	Output Connector	Input Length
	1x2 2x2	50/50 55/45 60/40 65/35 70/30 75/25 80/20 85/15 90/10 95/5	900=900 μm 3=3 mm	ULC = LC/UPC ALC = LC/APC USC = SC/UPC ASC = SC/APC UFC = FC/UPC AFC = FC/APC NC = No Connector	1M 2M 3M 4M 5M	ULC = LC/UPC ALC = LC/APC USC = SC/UPC ASC = SC/APC UFC = FC/UPC AFC = FC/APC NC = No Connector	1M 2M 3M 4M 5M



Optical Splitter Shelf

The LightLink LanSystem™ Optical Splitter Shelf provides a convenient in-rack solution to combine/split optical signals in a passive optical network. With 1x16, 1x32 and 2x32 options available, the splitter shelf also features a Planar Lightwave Circuit (PLC) allowing a signal to be split into either 16 or 32 channels in a 1U rack-mountable housing. The 2x32 option provides a filter WDM concatenated to a PLC, which allows 1310/1490/1550 nm signal management evenly across 32 channels.

Features

- Telcordia® GR-63 NEBS tested housing
- Aluminum Material per ASTM B209
- Universal Mounting Bracket WECO, EIA
- 19" and 23" Rack Mountable
- Rugged construction, ensuring environmental, mechanical and optical integrity
- WDM and PLC fully compliant to Telcordia GR-1209 and GR-1221
- Low Excess loss
- Low Polarization Dependent Loss

Applications

- PON-FTTx Networks
- CATV links
- DWDM and CWDM systems
- Wide area networks
- Outside plant requirements

Specifications

PARAMETER	1x16	1x32	2x32	
Insertion Loss	13.5 ~ 14.3 dB	17.5 - 18.5 dB	17.5 - 19 dB	
Uniformity	1.5 dB Typical	1.8 dB Typical	1.8 dB Typical	
PDL	≤ 0.3 dB	<0.45 dB	<0.45 dB	
Return Loss	≥ 55 dB	≥ 55 dB	≥ 40 dB	
Directivity	≥ 55 dB	≥ 55 dB	≥ 50 dB	
Fiber Type	SMF-28e	SMF-28e	SMF-28e	
Operating Temp	-40°C to +85°C	-40°C to +85°C	-40°C to +70°C	
Storage Temp	-40°C to +85°C	-40°C to +85°C	-40°C to +85°C	
Operating Bandwidth	1260 ~ 1650	1260 ~ 1650	1550 nm Band - Port 1 (Pass)	1550 - 1560 nm
			1310 + 1490 nm - Port 2 (Reflect)	1260-1360 nm & 1480-1500 nm

Ordering Information

DESCRIPTION	AFL NO.
1x16 Optical Splitter Shelf, ASC inputs/outputs, 1U, textured White	FM001000
1x32 Optical Splitter Shelf, ASC inputs/outputs, 1U, textured White	FM000775
2x32 Optical Splitter Shelf, ASC inputs/outputs, 1U, textured White	FM000622

Qualifications

GOVERNING BODY	STANDARD CODE
ASTM	ASTM B209
Telcordia	GR-63NEBS, GR-1209 and GR-1221



Optical FTTx Coupler Module

AFL's Optical FTTx Coupler Module is designed to satisfy requirements utilizing 1550 nm bandwidths in FTTx applications and is specified for FTTx video installations. The module features a compact footprint with adapter ports consisting of SC/APC adapter outputs.

Specifications

PARAMETER	VALUE
Performance	
Wavelength	1540-1560 nm
Insertion Loss	1550 < 3.9 dB
PDL	<0.2 dB
PMD	< 0.05 ps
Return Loss	> 55 dB
Directivity	> 55 dB
Operating Temperature	-40 to +75°C
Storage Temperature	-40 to +85 °C
Relative Humidity	0 to 90%
Optical Power	500 mW

PACKAGING	
Packaging Size	Standard Single Width LGX® Rack Module
Fiber Type	Low-Water-Peak Non-Dispersion Shifted SMF-28e
Connector Type	All ports – SC/APC, Green

Ordering Information

DESCRIPTION	AFL NO.
Optical FTTx Coupler Module	CM000072

Dimensions

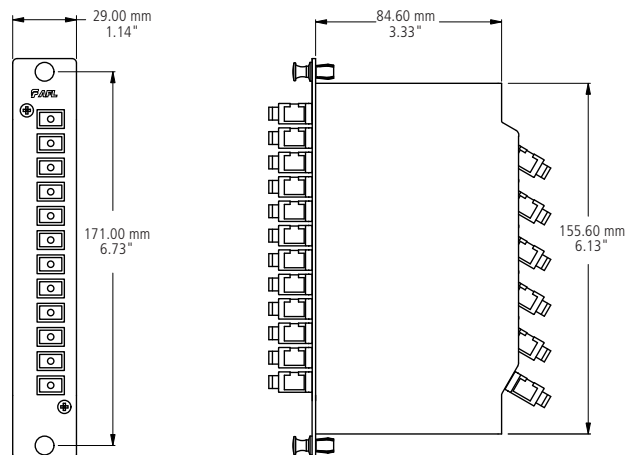

LGX is a registered trademark of Furukawa Electric North America, Inc.



LGX® FTTx Splitter Modules

The PON / FTTx splitters provide a convenient in-rack solution to combine or split optical signals in an optical network. Based on PLC technology, these modules offer the network operator high port-to-port uniformity and low insertion loss, as well as a wide operating wavelength range to accommodate future growth needs with new and emerging optical technologies. These products are available in LGX compatible modules.

Features

- Low excess loss
- Low polarization dependent loss
- Flexible LGX packaging options
(*see ordering information below for product size information)
- SC/APC Connectors

Applications

- PON - FTTx Networks
- Access Networks
- CATV Links
- Wide Area Networks

Performance Specifications

PARAMETER	1X4	1X8	1X16	1X32
Insertion Loss (dB) *	<7.4	<10.5	<13.9	<17.2
Uniformity (dB) *, **	<0.5	<0.8	<1.1	<1.5
PDL (dB) *, **	<0.3			
Return Loss (dB)	>55			
Directivity (dB)	>55			
Package	LGX, 1 Slot	LGX, 2 Slot	LGX, 3 Slot	LGX, 3 Slot

*Operating wavelength range (1260-1650 nm) guaranteed by design. Test report provided at 1310 and 1550 nm.

** Value does not include connector loss.

Ordering Information

DESCRIPTION	AFL NO.
1x4 Optical Splitter Module, 1260~1650 nm, Single slot LGX, Black, SC/APC	CM000474
1x8 Optical Splitter Module, 1260~1650 nm, Dual slot LGX, Black, SC/APC	CM000475
1x16 Optical Splitter Module, 1260~1650 nm, Triple slot LGX, Black, SC/APC	CM000476
1x32 Optical Splitter Module, 1260~1650 nm, Triple slot LGX, Black, SC/APC	CM000477

Qualifications

GOVERNING BODY	STANDARD CODE
Telcordia	GR-1209, GR1221

Temperature Specifications

TEMPERATURE RANGE	
Operation Temperature	-40°C to +85°C
Storage Temperature	-40°C to +85°C

Contact AFL for further details.



Double-width LGX 118 package shown

CWDM LGX Modules

AFL's Coarse WDM modules are designed using proven thin-film filter technology providing high isolation, 20 nm channel separation and a high level of thermal stability. CWDM modules are available in 2, 4, 8, and 16 channel configurations and are factory assembled in a thin cassette or rugged LGX® cassette with industry standard connector options to meet varying system requirements. An optional 1310 nm Mux/Demux Upgrade Port is available to allow seamless integration of legacy voice, video, and data services.

Features

- 20 nm channel spacing
- 2, 4, 8, and 16 channel configurations
- Most industry standard connectors
- Low insertion loss
- High isolation
- Custom configurations upon request

Applications

- CATV Systems
- Sensor Systems
- 10G Ethernet Systems
- Metro Optical Networks
- Metro Access Networks

Specifications

PARAMETER	VALUE			
Ports	2	4	8	16
Center Wavelength	1271-1611 nm			
Passband @ 0.5 dB	> 14 nm			
Passband	± 6.5 nm			
Passband Flatness	< 0.5 dB			
Insertion Loss (Typ.)	1.4 dB	1.6 dB	1.8 dB	4.3 dB
Insertion Loss (Max.)	1.8 dB	2.0 dB	2.5 dB	5.0 dB
Adjacent Channel Isolation	> 30 dB			
Non-Adjacent Channel Isolation	> 45 dB			
Wavelength Thermal Stability	< 0.002 nm/°C			
IL Thermal Stability	< 0.005 dB/°C	< 0.005 dB/°C	< 0.007 dB/°C	< 0.008 dB/°C
Return Loss	> 45 dB			
PMD	< 0.10 ps	< 0.10 ps	< 0.15 ps	< 0.15 ps
PDL	< 0.10 dB	< 0.15 dB	< 0.20 dB	< 0.25 dB
Directivity	> 50 dB			
LGX 118 Package	Single-width	Single-width	Double-width	Triple-width
Thin Cassette Package	88.9 x 50.8 x 8.3 mm	120 x 80 x 13 mm	130 x 87 x 13 mm	150 x 115 x 13 mm
Options	2% Tap, 1310 Upgrade			
1310 Channel Wavelength	1260-1360 nm			
1310 Channel Isolation	40 dB minimum			
1310 Channel Insertion Loss	1.3 dB maximum			

* Includes Connectors

continued
→

CWDM LGX Modules

Ordering Information

CWDM	04	5	1271	1331	B	ASC	ISP
	Channel Count	Package/Pigtail	Start Wavelength (nm)	End Wavelength (nm)	Options	Connectors	
	02 = 2 Channel 04 = 4 Channel 08 = 8 Channel 16 = 16 Channel	1 = Thin Cassette, 1 Meter Pigtail 3 = Thin Cassette, 3 Meter Pigtail 5 = Thin Cassette, 5 Meter Pigtail L = LGX 118	1271 1291 1311 1331 1351 1371 1391 1411 1431 1451 1471 1491 1511 1531 1551 1571 1591	1291 1311 1331 1351 1371 1391 1411 1431 1451 1471 1491 1511 1531 1551 1571 1591 1611	U = 1310 Upgrade Port T = 2% Tap Port X = No Option B = 1310 Upgrade Port and 2% Tap Port	ASC = SC/APC USC = SC/UPC ALC = LC/APC ULC = LC/UPC X = No connectors	

Qualifications

GOVERNING BODY	STANDARD CODE	COMPONENT
Telcordia	Compliant	Cable

Temperature Specifications

TEMPERATURE RANGE	
Operation Temperature	-5°C to +65°C
Storage Temperature	-40°C to +85°C

Contact AFL for further details.

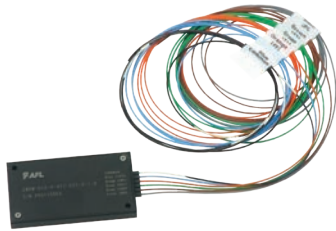

CWDM 4-Channel Mini Module

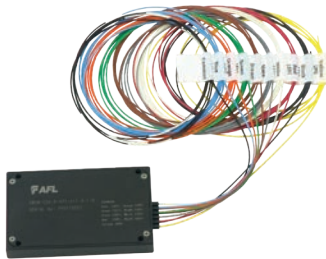

CWDM 8-Channel Mini Module

Thin Film Filter (TFF) Compact Series CWDM

AFL's TFF compact series CWDM modules deliver reliable performance and flexibility in every network application – from cellular backhaul and metro Ethernet to access and security. With its reduced package size, this new outside plant CWDM module has added flexibility, making deployment options more convenient.

This CWDM series is based on proven Thin Film Filter technology, offering low insertion loss and high thermal stability over the entire outside plant operating temperature range. Numerous configurations are available to meet unique needs and support new or existing network architectures. Typical options include a variety of configurations (mux, demux, and balanced), upgrade ports (1310, C-Band, and others), test/monitoring ports and multiple termination options.

Features

- Low insertion loss
- Compact size
- High thermal stability

Applications

- CWDM systems
- Metro Ethernet / access networks
- Cellular backhaul networks

Specifications

PARAMETER	UNIT	WITHOUT UPGRADE PORT		WITH 1310 NM UPGRADE PORT	
		4 Channel	8 Channel	4 Channel	8 Channel
Operating Wavelength	nm	1471~1611			
Channel Spacing	nm	20			
Center Wavelength	nm	Customer specified			
Pass Band	nm	± 6.5			
1310 Upgrade Port Pass Band	nm	—		1270~1350	
1310 Upgrade Port Insertion Loss	dB	—		1.0	
CWDM Channel Insertion Loss	dB	≤ 2.0	≤ 2.5	≤ 2.6	≤ 3.4
CWDM Adjacent Channel Isolation	dB	≥ 30			
CWDM Non-adjacent Channel Isolation	dB	≥ 45			
PDL	dB	≤ 0.2			
PMD	ps	≤ 0.1		≤ 0.25	
Return Loss	dB	≥ 45			
Directivity	dB	≥ 50			
Maximum Input Power	mW	≤ 300			
Package Size	Mm	60 (l) x 35 (w) x 6 (d)		70 (l) x 45 (w) x 9 (d)	

* Actual optical specifications will vary based on product configuration
 1. Higher and lower channel counts available

Qualifications

GOVERNING BODY	STANDARD CODE	COMPONENT
Telcordia	GR-1221-CORE	Cable
RoHS	6/6 Compliant	Cable

Temperature Specifications

TEMPERATURE RANGE	
Operation Temperature	-40°C ~ to +85°C

Contact AFL for further details.



CGM PLUS

CGM® PLUS

The CGM Plus is a high-density rack-mount panel designed for Wavelength Division Multiplexing (WDM) applications. The CGM Plus can hold LGX® and CGM® devices interchangeably.

The panel features a hinged tray system that extends from the front of the panel and conveniently folds out of the way for unobstructed access to installed modules.

Routing rings on the front of the tray provide enhanced fiber management, allowing cable assemblies to enter and exit comfortably.



CGM PLUS Open

Features

- Galvannealed Steel construction
- Textured white powder coat finish
- 4RU panel height
- Universal 19"/23" rack compatibility
- Hinged tray system for increased access to modules
- Compatible with CGM (Card Guide Module) and LGX products
- Adjustable mounting depth

Applications

- Wavelength Division Multiplexing (WDM)
- Headends/Central Offices
- Service Provider
- Telecommunications
- Data Centers

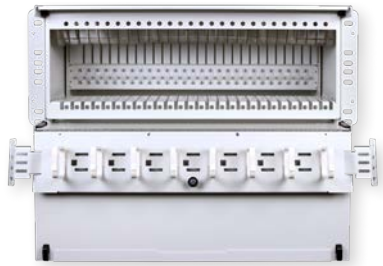

CGM PLUS Interior

Ordering Information

DESCRIPTION	CAPACITY		AFL NO.
	LGX*	CGM*	
CGM PLUS, 4RU, Empty, White, Front Access	12	24	FM004158

* Based on single-wide product

Specifications

DEPTH	WIDTH	HEIGHT	WEIGHT
12.5"	17.375"	6.875"	23 Lbs.



Card Guide Module (CGM®)

Card Guide Modules (CGM) are panel-mount WDM devices for high-density applications. These modules are pre-terminated plug and play products in a space efficient design. Using proven thin-film filter technology, Card Guide Modules feature low insertion loss, high isolation and superior environmental stability.

Available with up to 40 DWDM channels, Card Guide Modules can also be configured with optional Express, Upgrade or Test ports.

Features

- Space efficient design
- Mux/demux options
- LC/UPC or LC/APC adapters
- Up to 40 DWDM channels
- 50/100/200 GHz ITU channel spacing
- Optional Express, Upgrade or Test ports

Specifications

PARAMETER	UNIT	VALUE		
Channels	ea	8	20	40
CGM Size	Width	Single	Dual	Quad
Center Wavelength	nm	Per ITU-T G.694.1 Grid		
Channel Spacing	GHz	100		
Passband	nm	± 0.11		
Passband @ 0.5 dB	nm	> 14		
Passband Ripple	dB	< 0.5		
Insertion Loss (IL) (Typ.) **	dB	2.6	5.3	6.0
Insertion Loss (IL) (Max.) **	dB	3.2	5.8	6.5
Isolation (Adjacent Channel)	dB	≥ 25		
Isolation (Non-Adjacent Channel)	dB	≥ 40		
Return Loss (RL)	dB	≥ 45		
Directivity	dB	≥ 50		
Polarization Mode Dispersion (PMD)	ps	≤ 0.15		
Polarization Dependent Loss (PDL)	dB	≤ 0.25		
Wavelength Thermal Stability	nm/°C	< 0.001		
Insertion Loss Thermal Stability	dB/°C	< 0.007	< 0.007	< 0.008
Optical Power (Max.)	mW	300		
Options	Port	Express, Upgrade, Tap, Mux/Demux		

* Optical specifications do not include optional ports

** Includes Connectors

Temperature Specifications

TEMPERATURE RANGE	
Operating Temperature	-5°C to +70°C
Storage Temperature	-40°C to +85°C

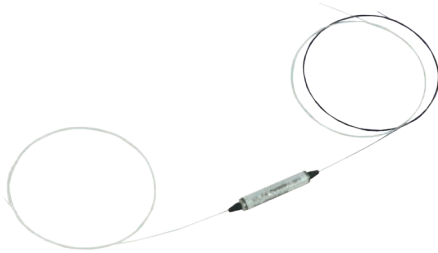

CWDM Single-channel OADM

The CWDM Single-channel OADM is designed to add/drop a single CWDM channel from an optical fiber. This product is hardened and designed to perform in OSP applications, but can also be used in splice trays or similar structures in Inside Plant or similar environments. While 250 μm leads are most commonly desired, these products can also be supplied with color-coded 900 μm leads and terminated with virtually any common single-fiber optical connector.

Features

- Hardened for OSP use
- Low Excess Loss
- Low PDL
- Color coded 900 μm leads available

Applications

- Metro Ethernet / Cellular Backhaul
- Access Networks
- CWDM Systems
- CATV Links

Specifications

PARAMETER	UNIT	VALUE
Center Wavelength	nm	ITU-T Grid
Channel Passband	nm	ITU-T Grid \pm 6.5
Passband Flatness	dB	< 0.5
Bandwidth (@ -5dB)	nm	>14
Insertion Loss (Pass Channel)	dB	< 1.0
Insertion Loss (Reflect Channel)	dB	< 0.6
Adjacent Channel Isolation	dB	> 30
Non-Adjacent Channel Isolation	dB	> 45
Isolation (Reflect Channel)	dB	> 13
Return Loss	dB	> 45
PDL	dB	< 0.1
Directivity	dB	> 50
IL Thermal Stability	dB/ $^{\circ}\text{C}$	< 0.005
Wavelength Thermal Stability	nm/ $^{\circ}\text{C}$	< 0.002
Operation Humidity	% RH	5 to 95 not condensed
Storage Humidity	% RH	0 to 95 not condensed

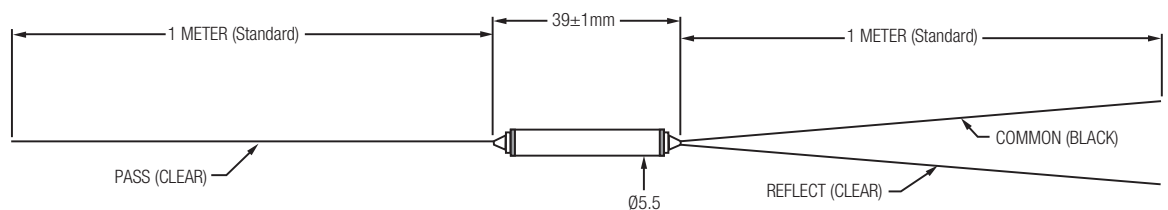

continued

CWDM Single-channel OADM

Ordering Information

AFL NO.	MODEL CODE	PASSBAND
CW000311-1431	CWDM TFF, 3-Port, 1431nm, 250um leads, NC, OSP	1431
CW000311-1451	CWDM TFF, 3-Port, 1451nm, 250um leads, NC, OSP	1451
CW000311-1471	CWDM TFF, 3-Port, 1471nm, 250um leads, NC, OSP	1471
CW000311-1491	CWDM TFF, 3-Port, 1491nm, 250um leads, NC, OSP	1491
CW000311-1511	CWDM TFF, 3-Port, 1511nm, 250um leads, NC, OSP	1511
CW000311-1531	CWDM TFF, 3-Port, 1531nm, 250um leads, NC, OSP	1531
CW000311-1551	CWDM TFF, 3-Port, 1551nm, 250um leads, NC, OSP	1551
CW000311-1571	CWDM TFF, 3-Port, 1571nm, 250um leads, NC, OSP	1571
CW000311-1591	CWDM TFF, 3-Port, 1591nm, 250um leads, NC, OSP	1591
CW000311-1611	CWDM TFF, 3-Port, 1611nm, 250um leads, NC, OSP	1611

* Additional configuration available upon request. Contact AFL Customer Service.

Qualifications

GOVERNING BODY	STANDARD CODE	COMPONENT
RoHS	Compliant	Cable

Temperature Specifications

TEMPERATURE RANGE	
Operation Temperature	-40°C to +85°C
Storage Temperature	-40°C to +85°C

Contact AFL for further details.

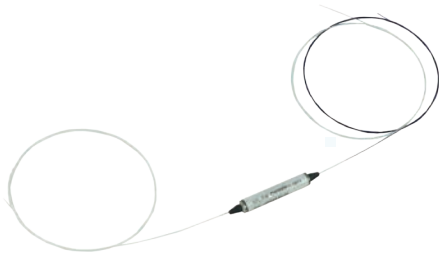

Dense Wave Division Multiplexing (DWDM) Single Fiber OADM

AFL's DWDM OADM provide scalable wavelength management for new deployments and network upgrades, providing add/ drop of a single fiber channel from a common optical fiber. Passive circuit design utilizes proven thin-film filter technology featuring low insertion loss, high isolation, and superior environmental stability. OADM devices are available with 250 μm or 900 μm tails and with multiple connector options.

Features

- 50 GHz and 100 GHz ITU-T channel spacing
- Low insertion loss/high isolation
- Epoxy-free optical path
- Express, upgrade and Tx/Rx test ports

Applications

- CATV Systems
- Carrier Infrastructure
- Access Networks
- Small Cell

Diagrams

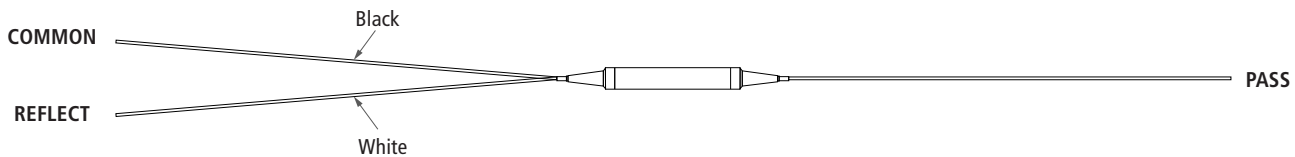
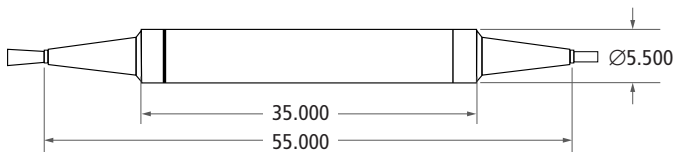

Ordering Information

Model	Specification	Package Style	ITU Channel Plan	Channel	Connectors	Length & UoM
DF	A	250	100	Cxx	XXX	1.0
DF = DWDM Filter	A = AFL Standard	250 = Bare Fiber (250 μm) 900 = Light Duty (900 μm)	050 = 50 GHz 100 = 100 GHz	Replace xx with Channel Number listed in DWDM ITU Channels table on last page of spec sheet. C19 = Channel 19 with 191, 900 GHz and 1562.23 nm center wavelength	AFC = FC/APC Connectors ALC = LC/APC Connectors ASC = SC/APC Connectors UFC = FC/UPC Connectors ULC = LC/UPC Connectors USC = SC/UPC Connectors XXX = No Connectors	0.5 = 0.5 Meter Tails 1.0 = 1.0 Meter Tails 1.5 = 1.5 Meter Tails 2.0 = 2.0 Meter Tails

continued

Dense Wave Division Multiplexing (DWDM) *Single Fiber OADM*

Optical Specifications* — DWDM, OADM, C and L Band, 50 GHz and 100 GHz Spacing

PARAMETER	REQUIREMENT			
	50 GHz		100 GHz	
Input Power and Temperature				
Max. Input Power Rating	300 mW			
Operating Temperature/Humidity	-40°C to 85°C; up to 95% RH			
Storage Temperature/Humidity	-40°C to 85°C; up to 95% RH			
Optical Passband				
Center Wavelength (λ_c) (nm)	See ITU Table on Page 3			
Passband	$\lambda_c \pm 0.06$ nm		$\lambda_c \pm 0.125$ nm	
Min. Bandwidth @ -0.5 dB Points	0.12 nm		0.25 nm	
Max. Passband Flatness	0.50 dB		0.50 dB	
Insertion Loss	w/o Connector	w/ Connector	w/o Connector	w/ Connector
Max. IL – Common to Pass	1.0 dB	1.5 dB	1.0 dB	1.5 dB
Max. IL – Common to Reflect	0.8 dB	1.3 dB	0.8 dB	1.3 dB
Isolation				
Min. Adjacent Channel Isolation	25 dB		25 dB	
Min. Non-Adjacent Channel Isolation	35 dB		45 dB	
Min. Reflect Channel Isolation	10 dB		12 dB	
Max. Polarization Dependent Loss (PDL)	0.15 dB			
Max. Polarization Mode Dispersion (PMD)	0.25 dB			
Directivity				
Min. Directivity	45 dB			
Min. Return Loss	45 dB			
Insertion Loss Thermal Stability				
Max. IL Thermal Stability	0.005 dB/C			
Max. Wavelength Thermal Stability	0.001 nm/C			

* Unless otherwise noted, optical specification applies across operating temperature range.

Qualifications

GOVERNING BODY	STANDARD CODE	COMPONENT
RoHS	Compliant	Cable

Temperature Specifications

	50 GHZ & 100 GHZ DWDM
Operation Temperature, Relative Humidity	-40°C to +85°C, up to 95 %
Storage Temperature, Relative Humidity	-40°C to +85°C, up to 95 %

Contact AFL for further details.

continued
→

Dense Wave Division Multiplexing (DWDM) *Single Fiber OADM*

DWDM ITU Channels

CHANNEL NO.	FREQUENCY (GHz)	CENTER WAVELENGTH (nm)	CHANNEL NO.	FREQUENCY (GHz)	CENTER WAVELENGTH (nm)	CHANNEL NO.	FREQUENCY (GHz)	CENTER WAVELENGTH (nm)	CHANNEL NO.	FREQUENCY (GHz)	CENTER WAVELENGTH (nm)
C1	190,100	1577.03	C19	191,900	1562.23	C37	193,700	1547.72	C55	195,500	1533.47
H1	190,150	1576.61	H19	191,950	1561.83	H37	193,750	1547.32	H55	195,550	1533.07
C2	190,200	1576.20	C20	192,000	1561.42	C38	193,800	1546.92	C56	195,600	1532.68
H2	190,250	1575.78	H20	192,050	1561.01	H38	193,850	1546.52	H56	195,650	1532.29
C3	190,300	1575.37	C21	192,100	1560.61	C39	193,900	1546.12	C57	195,700	1531.90
H3	190,350	1574.95	H21	192,150	1560.20	H39	193,950	1545.72	H57	195,750	1531.51
C4	190,400	1574.54	C22	192,200	1559.79	C40	194,000	1545.32	C58	195,800	1531.12
H4	190,450	1574.13	H22	192,250	1559.39	H40	194,050	1544.92	H58	195,850	1530.72
C5	190,500	1573.71	C23	192,300	1558.98	C41	194,100	1544.53	C59	195,900	1530.33
H5	190,550	1573.30	H23	192,350	1558.58	H41	194,150	1544.13	H59	195,950	1529.94
C6	190,600	1572.89	C24	192,400	1558.17	C42	194,200	1543.73	C60	196,000	1529.55
H6	190,650	1572.48	H24	192,450	1557.77	H42	194,250	1543.33	H60	196,050	1529.16
C7	190,700	1572.06	C25	192,500	1557.36	C43	194,300	1542.94	C61	196,100	1528.77
H7	190,750	1571.65	H25	192,550	1556.96	H43	194,350	1542.54	H61	196,150	1528.38
C8	190,800	1571.24	C26	192,600	1556.56	C44	194,400	1542.14	C62	196,200	1527.99
H8	190,850	1570.83	H26	192,650	1556.15	H44	194,450	1541.75	H62	196,250	1527.60
C9	190,900	1570.42	C27	192,700	1555.75	C45	194,500	1541.35	C63	196,300	1527.22
H9	190,950	1570.01	H27	192,750	1555.34	H45	194,550	1540.95	H63	196,350	1526.83
C10	191,000	1569.59	C28	192,800	1554.94	C46	194,600	1540.56	C64	196,400	1526.44
H10	191,050	1569.18	H28	192,850	1554.54	H46	194,650	1540.16	H64	196,450	1526.05
C11	191,100	1568.77	C29	192,900	1554.13	C47	194,700	1539.77	C65	196,500	1525.66
H11	191,150	1568.36	H29	192,950	1553.73	H47	194,750	1539.37	H65	196,550	1525.27
C12	191,200	1567.95	C30	193,000	1553.33	C48	194,800	1538.98	C66	196,600	1524.89
H12	191,250	1567.54	H30	193,050	1552.93	H48	194,850	1538.58	H66	196,650	1524.50
C13	191,300	1567.13	C31	193,100	1552.52	C49	194,900	1538.19	C67	196,700	1524.11
H13	191,350	1566.72	H31	193,150	1552.12	H49	194,950	1537.79	H67	196,750	1523.72
C14	191,400	1566.31	C32	193,200	1551.72	C50	195,000	1537.40	C68	196,800	1523.34
H14	191,450	1565.90	H32	193,250	1551.32	H50	195,050	1537.00	H68	196,850	1522.95
C15	191,500	1565.50	C33	193,300	1550.92	C51	195,100	1536.61	C69	196,900	1522.56
H15	191,550	1565.09	H33	193,350	1550.52	H51	195,150	1536.22	H69	196,950	1522.18
C16	191,600	1564.68	C34	193,400	1550.12	C52	195,200	1535.82	C70	197,000	1521.79
H16	191,650	1564.27	H34	193,450	1549.72	H52	195,250	1535.43	H70	197,050	1521.40
C17	191,700	1563.86	C35	193,500	1549.32	C53	195,300	1535.04	C71	197,100	1521.02
H17	191,750	1563.45	H35	193,550	1548.91	H53	195,350	1534.64	H71	197,150	1520.63
C18	191,800	1563.05	C36	193,600	1548.52	C54	195,400	1534.25	C72	197,200	1520.25
H18	191,850	1562.64	H36	193,650	1548.11	H54	195,450	1533.86	H72	197,250	1519.86

NOTES:

1. See Channel column to determine frequency and center wavelength values.
2. 100 GHz channels begin Cxx and 50 GHz channels begin with Cxx or Hxx.
3. Channels C16 (1564.68 nm) through C63 (1527.22 nm) reference C-BAND filter passband.



DWDM LGX Modules

AFL's DWDM LGX modules provide scalable wavelength management for new deployments and network upgrades, providing increased bandwidth over a single common fiber. Passive circuit design utilizes proven thin-film filter technology featuring low insertion loss, high isolation, and superior environmental stability. Modules can be installed in standard LGX chassis and are available with LC bulkheads in select configurations from 4 to 40 channels, including both single and dual circuit package designs. SC bulkhead modules are available in single circuit packages from 4 to 20 channels.

Features

- 50 GHz and 100 GHz ITU-T channel spacing
- Low insertion loss/high isolation
- Epoxy-free optical path
- Express, upgrade and Tx/Rx test ports

Applications

- CATV Systems
- Carrier Infrastructure
- Access Networks
- Small Cell

Diagram

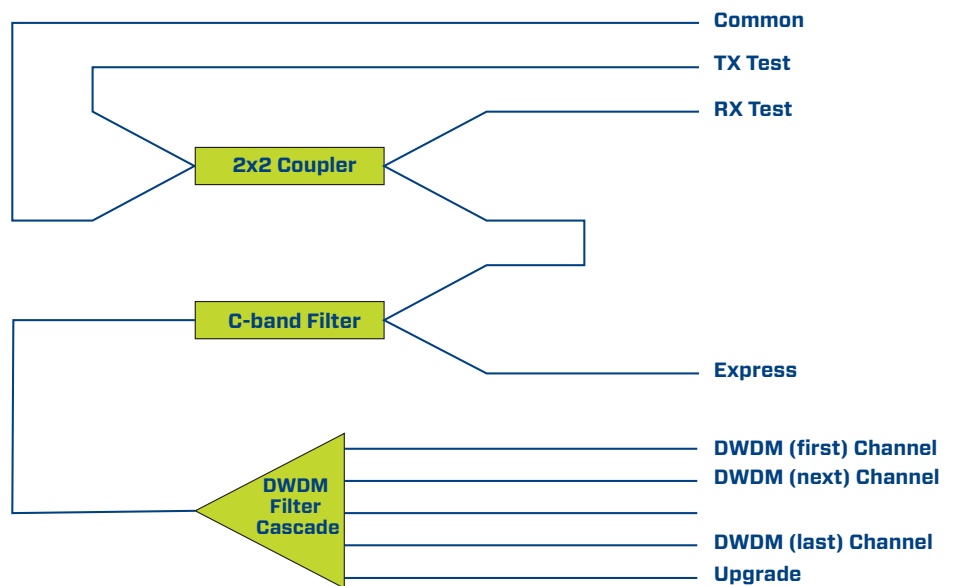

Ordering Information

Model	Specification	ITU Channel Plan	Channel Count	Package Size	Connectors	Channel	Network & Test Options**
D	C	1	S08	L01	ALCO	Cxx	F
D = Dense WDM	C = Commercial A = AFL Standard *	5 = 50 GHz 1 = 100 GHz	S04 = Single Circuit, 4 Channels D04 = Dual Circuit, 4 Channels S08 = Single Circuit, 8 Channels D08 = Dual Circuit, 8 Channels S10 = Single Circuit, 10 Channels D10 = Dual Circuit, 10 Channels S12 = Single Circuit, 12 Channels D12 = Dual Circuit, 12 Channels S16 = Single Circuit, 16 Channels D16 = Dual Circuit, 16 Channels S20 = Single Circuit, 20 Channels D20 = Dual Circuit, 20 Channels S40 = Single Circuit, 40 Channels D40 = Dual Circuit, 40 Channels	L01 = Single Wide LGX Module L02 = Double Wide LGX Module L03 = Triple Wide LGX Module L04 = Quad Wide LGX Module	ALCO = LC/APC Bulkhead ULCO = LC/UPC Bulkhead ASCO = SC/APC Bulkhead * USCO = SC/UPC Bulkhead *	Replace xx with Channel Number listed in DWDM ITU Channels table on last page of spec sheet. C19 = Channel 19 with 191, 900 GHz and 1562.23 nm center wavelength	0 = No Options 1 = Express 2 = Upgrade 3 = Express & Upgrade D = Express & Dual Test F = Express, Upgrade, & Dual Test

* SC bulkheads only available in AFL STANDARD (A) specification and single circuit channel counts of 4 to 20 channels.

** Additional options available, contact AFL for details.

continued →

DWDM LGX Modules

Optical Specifications *

ITU-T G.694.1 Configuration F (Express, Upgrade and Dual Test Ports)

PARAMETER	REQUIREMENT														COMMENT/COMMERCIAL SPEC VARIATION
	100 GHz							50 GHz							
Temperature and Input Power															
OT/H – Inside Plant	-10°C to 65°C; 5 to 95% RH														-20°C to 65°C; 5 to 95% RH
OT/H – Outside Plant	-40°C to 85°C; 5 to 95% RH														
Storage Temperature/Humidity	-40°C to 85°C; 5 to 95% RH														
Max. Input Power Rating	300 mW														
Optical Passband															
DWDM Channel Center Wavelength	per ITU 100 GHz Grid							per ITU 50 GHz Grid							
DWDM Channel Passband @ 0.5 dB	± 0.125 nm (ITU Channel Center Wavelength)							± 0.06 nm (ITU Channel Center Wavelength)							
DWDM Channel Passband Ripple	< 0.5														
Upgrade Port Optical Passband	1528.65 nm to 1566.44 nm														
Express Port Optical Passband	1260 nm to 1520 nm and 1570 nm to 1635 nm														
RX Test Optical Passband	1260 nm to 1635 nm														
TX Test Optical Passband	± 0.125 nm (ITU Channel Center Wavelength)							± 0.06 nm (ITU Channel Center Wavelength)							
Insertion Loss (New Product, 20°C to 25°C) ***															
Max IL (dB) – Common to DWDM Ch.	4 Ch	8 Ch	10 Ch	12 Ch	16 Ch	20 Ch	40 Ch	4 Ch	8 Ch	10 Ch	12 Ch	16 Ch	20 Ch	40 Ch	SC Bulkheads 4-20 channel only
	2.0	3.0	3.5	3.5	4.0	4.0	4.0	2.0	3.0	3.5	4.0	4.0	4.0	4.0	
Max DWDM Channel Uniformity	2.0 dB														
Max IL (dB) – Common to Upgrade	1.5	2.5	3.0	3.5	3.5	3.5	3.5	1.5	2.5	3.0	3.5	3.5	3.5	3.5	3.0 dB **
Max IL – Common to Express	1.0 dB														
Common to RX Test	≤21.0 dB														
Express to TX Test	≤22.0 dB														
Isolation															
Min DWDM Adjacent Channel Isolation	30 dB							25 dB							
Min DWDM Non-Adjacent Ch. Isolation	45 dB							35 dB							
Min Express Isolation	12 dB														
Max Polarization Dependent Loss (PDL)	0.3 dB														0.25 dB
Max Polarization Mode Dispersion (PMD)	0.3 dB														0.15 dB
Directivity															
DWDM Port Min Directivity	50 dB														55 dB
Express Port Min Directivity	45 dB														
Test Port Min Directivity	50 dB														
Min Return Loss (all ports)	45 dB														
Insertion Loss Thermal Stability															
Insertion Loss Thermal Stability – New Prod.	≤0.005 dB/C														
Insertion Loss Thermal Stability – Service Life	≤0.010 dB/C														< 0.005 dB/C
Wavelength Thermal Stability	≤0.001 nm/C														
LGX 118 Package (Slot Width)	4 Ch	8 Ch	10 Ch	12 Ch	16 Ch	20 Ch	40 Ch								
LC UPC/APC Bulkhead Mod. – Single Circ.	Single Slot	Single Slot	Single Slot	Single Slot	Single Slot	Single Slot	Single Slot	Single Slot	Single Slot	Single Slot	Single Slot	Single Slot	Single Slot	Dual Slot	
LC UPC/APC Bulkhead Mod. – Dual Circ.	Single Slot	Dual Slot	Dual Slot	Dual Slot	Dual Slot	Dual Slot	Dual Slot	Dual Slot	Dual Slot	Dual Slot	Dual Slot	Dual Slot	Dual Slot	Quad Slot	
SC UPC/APC Bulkhead Mod. – Single Circ.	Dual Slot	Dual Slot	Triple Slot	Triple Slot	Triple Slot	Triple Slot	Triple Slot	Quad Slot	Quad Slot	Quad Slot	Quad Slot	Quad Slot	Quad Slot	N/A	

NOTES:

* Unless otherwise noted, optical specification applies across operating temperature and optical bandpass.

** Includes connector loss.

*** Unless noted, 0.40 dB per mated connector loss is EXCLUDED.

continued
→

DWDM LGX Modules

DWDM ITU Channels

CHANNEL NO.	FREQUENCY (GHz)	CENTER WAVELENGTH (nm)	CHANNEL NO.	FREQUENCY (GHz)	CENTER WAVELENGTH (nm)	CHANNEL NO.	FREQUENCY (GHz)	CENTER WAVELENGTH (nm)	CHANNEL NO.	FREQUENCY (GHz)	CENTER WAVELENGTH (nm)
C1	190,100	1577.03	C19	191,900	1562.23	C37	193,700	1547.72	C55	195,500	1533.47
H1	190,150	1576.61	H19	191,950	1561.83	H37	193,750	1547.32	H55	195,550	1533.07
C2	190,200	1576.20	C20	192,000	1561.42	C38	193,800	1546.92	C56	195,600	1532.68
H2	190,250	1575.78	H20	192,050	1561.01	H38	193,850	1546.52	H56	195,650	1532.29
C3	190,300	1575.37	C21	192,100	1560.61	C39	193,900	1546.12	C57	195,700	1531.90
H3	190,350	1574.95	H21	192,150	1560.20	H39	193,950	1545.72	H57	195,750	1531.51
C4	190,400	1574.54	C22	192,200	1559.79	C40	194,000	1545.32	C58	195,800	1531.12
H4	190,450	1574.13	H22	192,250	1559.39	H40	194,050	1544.92	H58	195,850	1530.72
C5	190,500	1573.71	C23	192,300	1558.98	C41	194,100	1544.53	C59	195,900	1530.33
H5	190,550	1573.30	H23	192,350	1558.58	H41	194,150	1544.13	H59	195,950	1529.94
C6	190,600	1572.89	C24	192,400	1558.17	C42	194,200	1543.73	C60	196,000	1529.55
H6	190,650	1572.48	H24	192,450	1557.77	H42	194,250	1543.33	H60	196,050	1529.16
C7	190,700	1572.06	C25	192,500	1557.36	C43	194,300	1542.94	C61	196,100	1528.77
H7	190,750	1571.65	H25	192,550	1556.96	H43	194,350	1542.54	H61	196,150	1528.38
C8	190,800	1571.24	C26	192,600	1556.56	C44	194,400	1542.14	C62	196,200	1527.99
H8	190,850	1570.83	H26	192,650	1556.15	H44	194,450	1541.75	H62	196,250	1527.60
C9	190,900	1570.42	C27	192,700	1555.75	C45	194,500	1541.35	C63	196,300	1527.22
H9	190,950	1570.01	H27	192,750	1555.34	H45	194,550	1540.95	H63	196,350	1526.83
C10	191,000	1569.59	C28	192,800	1554.94	C46	194,600	1540.56	C64	196,400	1526.44
H10	191,050	1569.18	H28	192,850	1554.54	H46	194,650	1540.16	H64	196,450	1526.05
C11	191,100	1568.11	C29	192,900	1554.13	C47	194,700	1539.77	C65	196,500	1525.66
H11	191,150	1568.36	H29	192,950	1553.73	H47	194,750	1539.37	H65	196,550	1525.27
C12	191,200	1567.95	C30	193,000	1553.33	C48	194,800	1538.98	C66	196,600	1524.89
H12	191,250	1567.54	H30	193,050	1552.93	H48	194,850	1538.58	H66	196,650	1524.50
C13	191,300	1567.13	C31	193,100	1552.52	C49	194,900	1538.19	C67	196,700	1524.11
H13	191,350	1566.72	H31	193,150	1552.12	H49	194,950	1537.79	H67	196,750	1523.72
C14	191,400	1566.31	C32	193,200	1551.72	C50	195,000	1537.40	C68	196,800	1523.34
H14	191,450	1565.90	H32	193,250	1551.32	H50	195,050	1537.00	H68	196,850	1522.95
C15	191,500	1565.50	C33	193,300	1550.92	C51	195,100	1536.61	C69	196,900	1522.56
H15	191,550	1565.09	H33	193,350	1550.52	H51	195,150	1536.22	H69	196,950	1522.18
C16	191,600	1564.68	C34	193,400	1550.12	C52	195,200	1535.82	C70	197,000	1521.79
H16	191,650	1564.27	H34	193,450	1549.72	H52	195,250	1535.43	H70	197,050	1521.40
C17	191,700	1563.86	C35	193,500	1549.32	C53	195,300	1535.04	C71	197,100	1521.02
H17	191,750	1563.45	H35	193,550	1548.91	H53	195,350	1534.64	H71	197,150	1520.63
C18	191,800	1563.05	C36	193,600	1548.52	C54	195,400	1534.25	C72	197,200	1520.25
H18	191,850	1562.64	H36	193,650	1548.11	H54	195,450	1533.86	H72	197,250	1519.86

NOTES:

1. See Channel column to determine frequency and center wavelength values.
2. 100 GHz channels begin Cxx and 50 GHz channels begin with Cxx or Hxx.
3. Channels C16 (1564.68 nm) through C63 (1527.22 nm) reference C-BAND filter passband.

Temperature Specifications *

	50 GHz & 100 GHz DWDM	COMMERCIAL SPEC VARIATION
Operation Temperature, Relative Humidity Inside Plant	-10°C to +65°C; 5 to 95% RH	-20°C to 65°C; 5 to 95% RH
Outside Plant	-40°C to 85°C; 5 to 95% RH	
Storage Temperature, Relative Humidity	-40°C to 85°C; 5 to 95% RH	

* Unless otherwise noted, optical specification applies across operating temperature and optical bandpass.

Contact AFL for further details.

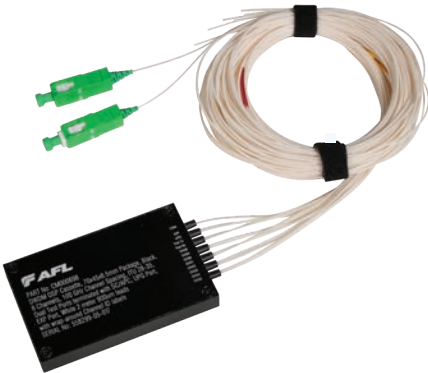

Dense Wave Division Multiplexing (DWDM) Cassette Modules

AFL's DWDM Cassette Modules provide scalable wavelength management for new deployments and network upgrades, providing increased bandwidth over a single common fiber. Passive circuit design utilizes proven thin-film filter technology featuring low insertion loss, high isolation, and superior environmental stability. Cassettes can be installed in OSP splice closures or cabinets and are available with 900 μm in select configurations from 4 to 40 channels. Test ports can be factory terminated with SC connectors for plug-and-play field optical testing.

Features

- 50 GHz and 100 GHz ITU-T channel spacing
- Low insertion loss/high isolation
- Epoxy-free optical path
- Express, upgrade and Tx/Rx test ports

Applications

- CATV Systems
- Carrier Infrastructure
- Access Networks
- Small Cell

Diagram

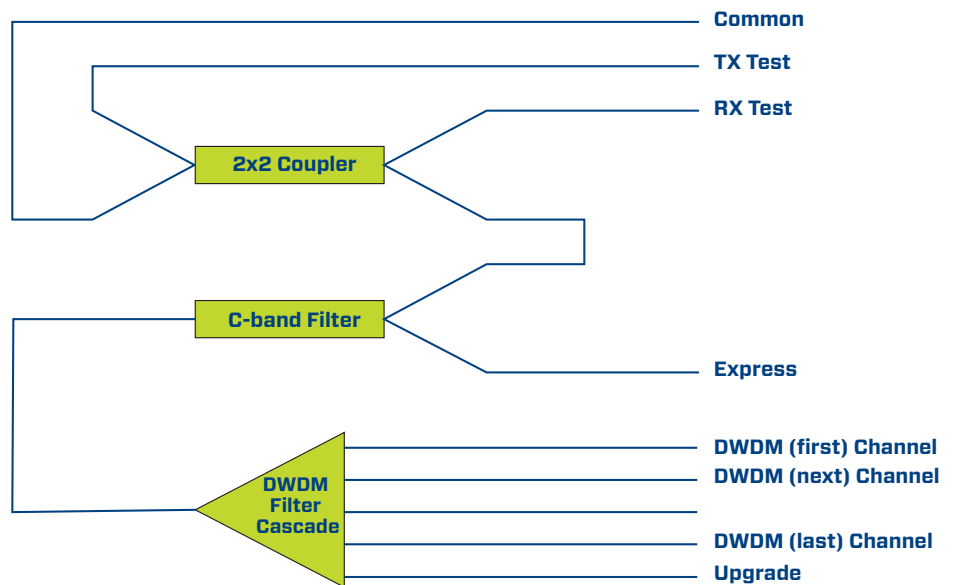

Ordering Information

Model	Specification	ITU Channel Plan	Channel Count	Package Size & 900 μm Fiber Color	Fiber Length & Connector Type*	Channel	Network & Test Options**
D	C	1	S08	01M	ALCO	Cxx	F
D = Dense WDM	C = Commercial A = AFL Standard	5 = 50 GHz 1 = 100 GHz	S04 = Single Circuit, 4 Channels S08 = Single Circuit, 8 Channels S10 = Single Circuit, 10 Channels S12 = Single Circuit, 12 Channels S16 = Single Circuit, 16 Channels S20 = Single Circuit, 20 Channels S40 = Single Circuit, 40 Channels	01W = 70x45x8.5 mm/White 01M = 70x45x8.5 mm/Color 02W = 75x85x8.5 mm/White 02M = 75x85x8.5 mm/Color 03W = 150x110x19 mm/White 03M = 150x110x19 mm/Color	ASC1 = 1M, SC/APC ASC2 = 2M, SC/UPC XXX1 = 1M, No Connector XXX2 = 2M, No Connector	Replace xx with Channel Number listed in DWDM ITU Channels table on last page of spec sheet. C19 = Channel 19 with 191, 900 GHz and 1562.23 nm center wavelength	0 = No Options 1 = Express 2 = Upgrade 3 = Express & Upgrade D = Express & Dual Test F = Express, Upgrade, & Dual Test

* Connector type selection only for Rx and/or Tx port fibers (if applicable), all other port tails without connectors.

** Additional options available, contact AFL for details.

continued

Dense Wave Division Multiplexing (DWDM) Cassette Modules

Optical Specifications *

ITU-T G.694.1 Configuration F (Express, Upgrade and Dual Test Ports)

PARAMETER	REQUIREMENT														COMMENT/COMMERCIAL SPEC VARIATION
	100 GHz							50 GHz							
Temperature and Input Power															
Operating Temperature/Humidity	-40°C to 85°C; 5 to 95% RH														
Storage Temperature/Humidity	-40°C to 85°C; 5 to 95% RH														
Max. Input Power Rating	300 mW														
Optical Passband															
DWDM Channel Center Wavelength	per ITU 100 GHz Grid							per ITU 50 GHz Grid							
DWDM Channel Passband @ 0.5 dB	± 0.125 nm (ITU Channel Center Wavelength)							± 0.06 nm (ITU Channel Center Wavelength)							
DWDM Channel Passband Ripple	< 0.5														
Upgrade Port Optical Passband	1528.65 nm to 1566.44 nm														
Express Port Optical Passband	1260 nm to 1520 nm and 1570 nm to 1635 nm														
RX Test Optical Passband	1260 nm to 1635 nm														
TX Test Optical Passband	± 0.125 nm (ITU Channel Center Wavelength)							± 0.06 nm (ITU Channel Center Wavelength)							
Insertion Loss (New Product, 20°C to 25°C)															
Max IL (dB) – Common to DWDM Ch.	4 Ch	8 Ch	10 Ch	12 Ch	16 Ch	20 Ch	40 Ch	4 Ch	8 Ch	10 Ch	12 Ch	16 Ch	20 Ch	40 Ch	
	2.0	3.0	3.5	3.5	4.0	4.0	4.0	2.0	3.0	3.5	4.0	4.0	4.0	4.0	
Max DWDM Channel Uniformity	2.0 dB														
Max IL (dB) – Common to Upgrade	1.5	2.5	3.0	3.5	3.5	3.5	3.5	1.5	2.5	3.0	3.5	3.5	3.5	3.5	3.0 dB
Max IL – Common to Express	1.0 dB														
Common to RX Test	≤21.0 dB **														
Express to TX Test	≤22.0 dB **														
Isolation															
Min DWDM Adjacent Channel Isolation	30 dB							25 dB							
Min DWDM Non-Adjacent Ch. Isolation	45 dB							35 dB							
Min Express Isolation	12 dB														
Max Polarization Dependent Loss (PDL)	0.3 dB														0.25 dB
Max Polarization Mode Dispersion (PMD)	0.3 dB														0.15 dB
Directivity															
DWDM Port Min Directivity	50 dB														55 dB
Express Port Min Directivity	45 dB														
Test Port Min Directivity	50 dB														
Min Return Loss (all ports)	45 dB														
Insertion Loss Thermal Stability															
Insertion Loss Thermal Stability – New Prod.	≤0.005 dB/C														
Insertion Loss Thermal Stability – Service Life	≤0.010 dB/C														< 0.005 dB/C
Wavelength Thermal Stability	≤0.001 nm/C														
Cassette Module Package Size	4 Ch	8 Ch	10 Ch	12 Ch	16 Ch	20 Ch	40 Ch								
70 x 45 x 8.5 mm (01W/M)	X	X													
75 x 85 x 8.5 mm (02W/M)			X	X	X	X									
150 x 110 x 19 mm (03W/M)													X		

NOTES:

* Unless otherwise noted, optical specification applies across operating temperature and optical bandpass.

** Unless noted, 0.40 dB per mated connector loss is EXCLUDED.

continued
→

Dense Wave Division Multiplexing (DWDM) Cassette Modules

DWDM ITU Channels

CHANNEL NO.	FREQUENCY (GHz)	CENTER WAVELENGTH (nm)	CHANNEL NO.	FREQUENCY (GHz)	CENTER WAVELENGTH (nm)	CHANNEL NO.	FREQUENCY (GHz)	CENTER WAVELENGTH (nm)	CHANNEL NO.	FREQUENCY (GHz)	CENTER WAVELENGTH (nm)
C1	190,100	1577.03	C19	191,900	1562.23	C37	193,700	1547.72	C55	195,500	1533.47
H1	190,150	1576.61	H19	191,950	1561.83	H37	193,750	1547.32	H55	195,550	1533.07
C2	190,200	1576.20	C20	192,000	1561.42	C38	193,800	1546.92	C56	195,600	1532.68
H2	190,250	1575.78	H20	192,050	1561.01	H38	193,850	1546.52	H56	195,650	1532.29
C3	190,300	1575.37	C21	192,100	1560.61	C39	193,900	1546.12	C57	195,700	1531.90
H3	190,350	1574.95	H21	192,150	1560.20	H39	193,950	1545.72	H57	195,750	1531.51
C4	190,400	1574.54	C22	192,200	1559.79	C40	194,000	1545.32	C58	195,800	1531.12
H4	190,450	1574.13	H22	192,250	1559.39	H40	194,050	1544.92	H58	195,850	1530.72
C5	190,500	1573.71	C23	192,300	1558.98	C41	194,100	1544.53	C59	195,900	1530.33
H5	190,550	1573.30	H23	192,350	1558.58	H41	194,150	1544.13	H59	195,950	1529.94
C6	190,600	1572.89	C24	192,400	1558.17	C42	194,200	1543.73	C60	196,000	1529.55
H6	190,650	1572.48	H24	192,450	1557.77	H42	194,250	1543.33	H60	196,050	1529.16
C7	190,700	1572.06	C25	192,500	1557.36	C43	194,300	1542.94	C61	196,100	1528.77
H7	190,750	1571.65	H25	192,550	1556.96	H43	194,350	1542.54	H61	196,150	1528.38
C8	190,800	1571.24	C26	192,600	1556.56	C44	194,400	1542.14	C62	196,200	1527.99
H8	190,850	1570.83	H26	192,650	1556.15	H44	194,450	1541.75	H62	196,250	1527.60
C9	190,900	1570.42	C27	192,700	1555.75	C45	194,500	1541.35	C63	196,300	1527.22
H9	190,950	1570.01	H27	192,750	1555.34	H45	194,550	1540.95	H63	196,350	1526.83
C10	191,000	1569.59	C28	192,800	1554.94	C46	194,600	1540.56	C64	196,400	1526.44
H10	191,050	1569.18	H28	192,850	1554.54	H46	194,650	1540.16	H64	196,450	1526.05
C11	191,100	1568.77	C29	192,900	1554.13	C47	194,700	1539.77	C65	196,500	1525.66
H11	191,150	1568.36	H29	192,950	1553.73	H47	194,750	1539.37	H65	196,550	1525.27
C12	191,200	1567.95	C30	193,000	1553.33	C48	194,800	1538.98	C66	196,600	1524.89
H12	191,250	1567.54	H30	193,050	1552.93	H48	194,850	1538.58	H66	196,650	1524.50
C13	191,300	1567.13	C31	193,100	1552.52	C49	194,900	1538.19	C67	196,700	1524.11
H13	191,350	1566.72	H31	193,150	1552.12	H49	194,950	1537.79	H67	196,750	1523.72
C14	191,400	1566.31	C32	193,200	1551.72	C50	195,000	1537.40	C68	196,800	1523.34
H14	191,450	1565.90	H32	193,250	1551.32	H50	195,050	1537.00	H68	196,850	1522.95
C15	191,500	1565.50	C33	193,300	1550.92	C51	195,100	1536.61	C69	196,900	1522.56
H15	191,550	1565.09	H33	193,350	1550.52	H51	195,150	1536.22	H69	196,950	1522.18
C16	191,600	1564.68	C34	193,400	1550.12	C52	195,200	1535.82	C70	197,000	1521.79
H16	191,650	1564.27	H34	193,450	1549.72	H52	195,250	1535.43	H70	197,050	1521.40
C17	191,700	1563.86	C35	193,500	1549.32	C53	195,300	1535.04	C71	197,100	1521.02
H17	191,750	1563.45	H35	193,550	1548.91	H53	195,350	1534.64	H71	197,150	1520.63
C18	191,800	1563.05	C36	193,600	1548.52	C54	195,400	1534.25	C72	197,200	1520.25
H18	191,850	1562.64	H36	193,650	1548.11	H54	195,450	1533.86	H72	197,250	1519.86

NOTES:

1. See Channel column to determine frequency and center wavelength values.
2. 100 GHz channels begin Cxx and 50 GHz channels begin with Hxx or Hxx.
3. Channels C16 (1564.68 nm) through C63 (1527.22 nm) reference C-BAND filter passband.

Temperature Specifications *

	50 GHz & 100 GHz DWDM
Operation Temperature, Relative Humidity	-40°C to 85°C; 5 to 95% RH
Storage Temperature, Relative Humidity	-40°C to 85°C; 5 to 95% RH

* Unless otherwise noted, optical specification applies across operating temperature and optical bandpass.

Contact AFL for further details.



Dense Wave Division Multiplexing (DWDM) Card Guide Modules (CGM®)

AFL's DWDM CGM modules provide scalable wavelength management for new deployments and network upgrades, providing increased bandwidth over a single common fiber. Passive circuit design utilizes proven thin-film filter technology featuring low insertion loss, high isolation, and superior environmental stability. Modules can be installed in AFL's CGM *Plus* chassis and are available with LC bulkheads in select configurations from 4 to 40 channels. The CGM module space efficient design allows for installation quantity of 24 modules in a single 4RU CGM Plus chassis.

Features

- 50 GHz and 100 GHz ITU-T channel spacing
- Low insertion loss/high isolation
- Epoxy-free optical path
- Express, upgrade and Tx/Rx test ports

Applications

- CATV Systems
- Carrier Infrastructure
- Access Networks
- Small Cell

Diagram

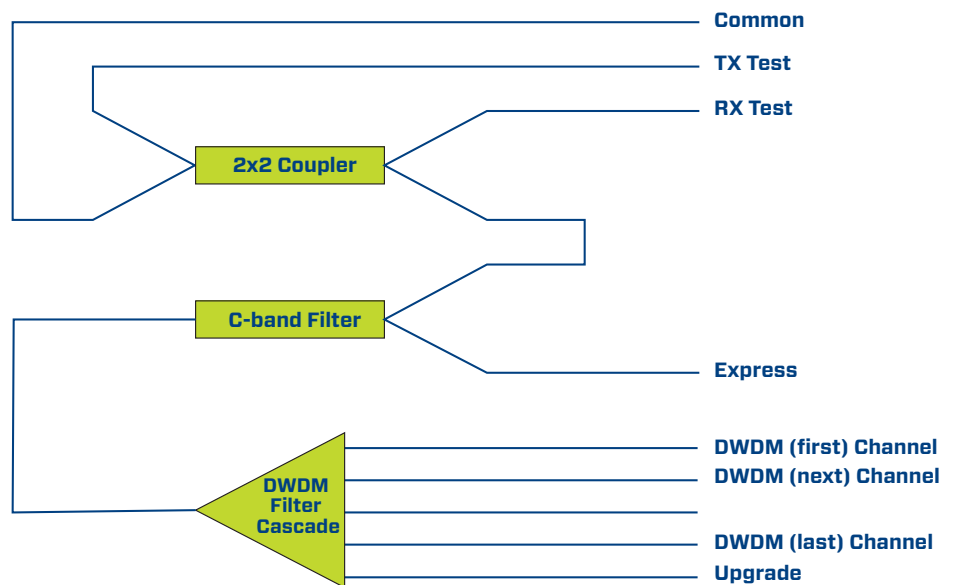

Ordering Information

Model	Specification	ITU Channel Plan	Channel Count	Package Size	Connectors	Channel	Network & Test Options*
D	C	1	S08	C02	ALCO	Cxx	F
D = Dense WDM	C = Commercial A = AFL Standard	5 = 50 GHz 1 = 100 GHz	S04 = Single Circuit, 4 Channels S08 = Single Circuit, 8 Channels S12 = Single Circuit, 12 Channels S16 = Single Circuit, 16 Channels S20 = Single Circuit, 20 Channels S40 = Single Circuit, 40 Channels	C01 = Single Wide CGM C02 = Double Wide CGM C03 = Triple Wide CGM C04 = Quad Wide CGM	ALCO = LC/APC Bulkhead ULCO = LC/UPC Bulkhead	Replace xx with Channel Number listed in DWDM ITU Channels table on last page of spec sheet. C19 = Channel 19 with 191, 900 GHz and 1562.23 nm center wavelength	0 = No Options 1 = Express 2 = Upgrade 3 = Express & Upgrade D = Express & Dual Test F = Express, Upgrade, & Dual Test

* Additional options available, contact AFL for details.

continued
➔

Dense Wave Division Multiplexing (DWDM) Card Guide Modules (CGM®)

Optical Specifications *

ITU-T G.694.1 Configuration F (Express, Upgrade and Dual Test Ports)

PARAMETER	REQUIREMENT										COMMENT/COMMERCIAL SPEC VARIATION	
	100 GHz					50 GHz						
Temperature and Input Power												
OT/H – Inside Plant	-10°C to 65°C; 5 to 95% RH										-20°C to 65°C; 5 to 95% RH	
OT/H – Outside Plant	-40°C to 85°C; 5 to 95% RH											
Storage Temperature/Humidity	-40°C to 85°C; 5 to 95% RH											
Max. Input Power Rating	300 mW											
Optical Passband												
DWDM Channel Center Wavelength	per ITU 100 GHz Grid					per ITU 50 GHz Grid						
DWDM Channel Passband @ 0.5 dB	± 0.125 nm (ITU Channel Center Wavelength)					± 0.06 nm (ITU Channel Center Wavelength)						
DWDM Channel Passband Ripple	< 0.5											
Upgrade Port Optical Passband	1528.65 nm to 1566.44 nm											
Express Port Optical Passband	1260 nm to 1520 nm and 1570 nm to 1635 nm											
RX Test Optical Passband	1260 nm to 1635 nm											
TX Test Optical Passband	± 0.125 nm (ITU Channel Center Wavelength)					± 0.06 nm (ITU Channel Center Wavelength)						
Insertion Loss (New Product, 20°C to 25°C) ***												
Max IL (dB) – Common to DWDM Ch.	4 Ch	8 Ch	16 Ch	20 Ch	40 Ch	4 Ch	8 Ch	12 Ch	16 Ch	20 Ch	40 Ch	
	2.0	3.0	4.0	4.0	4.0	2.0	3.0	4.0	4.0	4.0	4.0	
Max DWDM Channel Uniformity	2.0 dB											
Max IL (dB) – Common to Upgrade	1.5	2.5	3.5	3.5	3.5	1.5	2.5	3.5	3.5	3.5	3.5	3.0 dB **
Max IL – Common to Express	1.0 dB											
Common to RX Test	≤21.0 dB											
Express to TX Test	≤22.0 dB											
Isolation												
Min DWDM Adjacent Channel Isolation	30 dB					25 dB						
Min DWDM Non-Adjacent Ch. Isolation	45 dB					35 dB						
Min Express Isolation	12 dB											
Max Polarization Dependent Loss (PDL)	0.3 dB										0.25 dB	
Max Polarization Mode Dispersion (PMD)	0.3 dB										0.15 dB	
Directivity												
DWDM Port Min Directivity	50 dB										55 dB	
Express Port Min Directivity	45 dB											
Test Port Min Directivity	50 dB											
Min Return Loss (all ports)	45 dB											
Insertion Loss Thermal Stability												
Insertion Loss Thermal Stability – New Prod.	≤0.005 dB/C											
Insertion Loss Thermal Stability – Service Life	≤0.010 dB/C										< 0.005 dB/C	
Wavelength Thermal Stability	≤0.001 nm/C											
LGX 118 Package (Slot Width)												
CGM Package Width	4 Ch	8 Ch	12 Ch	16 Ch	20 Ch	40 Ch						
	Single Slot	Dual Slot	Dual Slot	Dual Slot	Triple Slot	Quad Slot						

NOTES:

* Unless otherwise noted, optical specification applies across operating temperature and optical bandpass.

** Includes connector loss.

*** Unless noted, 0.40 dB per mated connector loss is EXCLUDED.

continued
→

Dense Wave Division Multiplexing (DWDM) Card Guide Modules (CGM®)

DWDM ITU Channels

CHANNEL NO.	FREQUENCY (GHz)	CENTER WAVELENGTH (nm)	CHANNEL NO.	FREQUENCY (GHz)	CENTER WAVELENGTH (nm)	CHANNEL NO.	FREQUENCY (GHz)	CENTER WAVELENGTH (nm)	CHANNEL NO.	FREQUENCY (GHz)	CENTER WAVELENGTH (nm)
C1	190,100	1577.03	C19	191,900	1562.23	C37	193,700	1547.72	C55	195,500	1533.47
H1	190,150	1576.61	H19	191,950	1561.83	H37	193,750	1547.32	H55	195,550	1533.07
C2	190,200	1576.20	C20	192,000	1561.42	C38	193,800	1546.92	C56	195,600	1532.68
H2	190,250	1575.78	H20	192,050	1561.01	H38	193,850	1546.52	H56	195,650	1532.29
C3	190,300	1575.37	C21	192,100	1560.61	C39	193,900	1546.12	C57	195,700	1531.90
H3	190,350	1574.95	H21	192,150	1560.20	H39	193,950	1545.72	H57	195,750	1531.51
C4	190,400	1574.54	C22	192,200	1559.79	C40	194,000	1545.32	C58	195,800	1531.12
H4	190,450	1574.13	H22	192,250	1559.39	H40	194,050	1544.92	H58	195,850	1530.72
C5	190,500	1573.71	C23	192,300	1558.98	C41	194,100	1544.53	C59	195,900	1530.33
H5	190,550	1573.30	H23	192,350	1558.58	H41	194,150	1544.13	H59	195,950	1529.94
C6	190,600	1572.89	C24	192,400	1558.17	C42	194,200	1543.73	C60	196,000	1529.55
H6	190,650	1572.48	H24	192,450	1557.77	H42	194,250	1543.33	H60	196,050	1529.16
C7	190,700	1572.06	C25	192,500	1557.36	C43	194,300	1542.94	C61	196,100	1528.77
H7	190,750	1571.65	H25	192,550	1556.96	H43	194,350	1542.54	H61	196,150	1528.38
C8	190,800	1571.24	C26	192,600	1556.56	C44	194,400	1542.14	C62	196,200	1527.99
H8	190,850	1570.83	H26	192,650	1556.15	H44	194,450	1541.75	H62	196,250	1527.60
C9	190,900	1570.42	C27	192,700	1555.75	C45	194,500	1541.35	C63	196,300	1527.22
H9	190,950	1570.01	H27	192,750	1555.34	H45	194,550	1540.95	H63	196,350	1526.83
C10	191,000	1569.59	C28	192,800	1554.94	C46	194,600	1540.56	C64	196,400	1526.44
H10	191,050	1569.18	H28	192,850	1554.54	H46	194,650	1540.16	H64	196,450	1526.05
C11	191,100	1568.77	C29	192,900	1554.13	C47	194,700	1539.77	C65	196,500	1525.66
H11	191,150	1568.36	H29	192,950	1553.73	H47	194,750	1539.37	H65	196,550	1525.27
C12	191,200	1567.95	C30	193,000	1553.33	C48	194,800	1538.98	C66	196,600	1524.89
H12	191,250	1567.54	H30	193,050	1552.93	H48	194,850	1538.58	H66	196,650	1524.50
C13	191,300	1567.13	C31	193,100	1552.52	C49	194,900	1538.19	C67	196,700	1524.11
H13	191,350	1566.72	H31	193,150	1552.12	H49	194,950	1537.79	H67	196,750	1523.72
C14	191,400	1566.31	C32	193,200	1551.72	C50	195,000	1537.40	C68	196,800	1523.34
H14	191,450	1565.90	H32	193,250	1551.32	H50	195,050	1537.00	H68	196,850	1522.95
C15	191,500	1565.50	C33	193,300	1550.92	C51	195,100	1536.61	C69	196,900	1522.56
H15	191,550	1565.09	H33	193,350	1550.52	H51	195,150	1536.22	H69	196,950	1522.18
C16	191,600	1564.68	C34	193,400	1550.12	C52	195,200	1535.82	C70	197,000	1521.79
H16	191,650	1564.27	H34	193,450	1549.72	H52	195,250	1535.43	H70	197,050	1521.40
C17	191,700	1563.86	C35	193,500	1549.32	C53	195,300	1535.04	C71	197,100	1521.02
H17	191,750	1563.45	H35	193,550	1548.91	H53	195,350	1534.64	H71	197,150	1520.63
C18	191,800	1563.05	C36	193,600	1548.52	C54	195,400	1534.25	C72	197,200	1520.25
H18	191,850	1562.64	H36	193,650	1548.11	H54	195,450	1533.86	H72	197,250	1519.86

NOTES:

1. See Channel column to determine frequency and center wavelength values.
2. 100 GHz channels begin Cxx and 50 GHz channels begin with Hxx or Hxx.
3. Channels C16 (1564.68 nm) through C63 (1527.22 nm) reference C-BAND filter passband.

Temperature Specifications *

	50 GHz & 100 GHz DWDM	COMMERCIAL SPEC VARIATION
Operation Temperature, Relative Humidity Inside Plant	-10°C to +65°C; 5 to 95% RH	-20°C to 65°C; 5 to 95% RH
Outside Plant	-40°C to 85°C; 5 to 95% RH	
Storage Temperature, Relative Humidity	-40°C to 85°C; 5 to 95% RH	

* Unless otherwise noted, optical specification applies across operating temperature and optical bandpass.

Contact AFL for further details.



Dense Wave Division Multiplexing (DWDM) Rack-Mount Panels

AFL's DWDM Rack-mount Panels provide scalable wavelength management for new deployments and network upgrades, providing increased bandwidth over a single common fiber. Passive circuit design utilizes proven thin-film filter technology featuring low insertion loss, high isolation, and superior environmental stability. Panels can be installed in standard 19/23" racks and are available with LC bulkheads in 20 and 40 channel configurations, including both single and dual circuit package designs. SC bulkhead modules are available in single circuit packages only with 20 or 40 channels.

Features

- 50 GHz and 100 GHz ITU-T channel spacing
- Low insertion loss/high isolation
- Epoxy-free optical path
- Express, upgrade and Tx/Rx test ports

Applications

- CATV Systems
- Carrier Infrastructure
- Access Networks
- Small Cell

Diagram

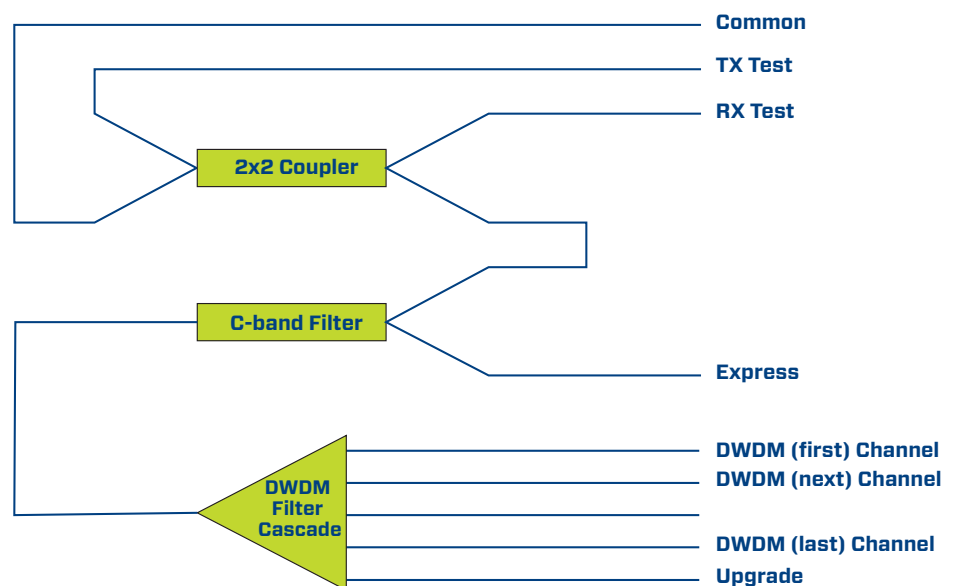

Ordering Information

Model	Specification	ITU Channel Plan	Channel Count	Package Size	Connectors	Channel	Network & Test Options**
D	C	1	S40	1RU	ALCO	Cxx	F
D = Dense WDM	C = Commercial A = AFL Standard *	5 = 50 GHz 1 = 100 GHz	S20 = Single Circuit, 20 Channels D20 = Dual Circuit, 20 Channels S40 = Single Circuit, 40 Channels D40 = Dual Circuit, 40 Channels	1RU = 1 RU Panel	ALCO = LC/APC Bulkhead ULCO = LC/UPC Bulkhead ASCO = SC/APC Bulkhead * USCO = SC/UPC Bulkhead *	Replace xx with Channel Number listed in DWDM ITU Channels table on last page of spec sheet. C19 = Channel 19 with 191, 900 GHz and 1562.23 nm center wavelength	0 = No Options 1 = Express 2 = Upgrade 3 = Express & Upgrade D = Express & Dual Test F = Express, Upgrade, & Dual Test

* SC bulkheads only available in AFL STANDARD (A) specification and single circuit channel counts of 20 and 40 channels.

** Additional options available, contact AFL for details.

continued →

Dense Wave Division Multiplexing (DWDM) Rack-Mount Panels

Optical Specifications *

ITU-T G.694.1 Configuration F (Express, Upgrade and Dual Test Ports)

PARAMETER	REQUIREMENT				COMMENT/COMMERCIAL SPEC VARIATION
	100 GHz		50 GHz		
Temperature and Input Power					
OT/H – Inside Plant	-10°C to 65°C; 5 to 95% RH				-20°C to 65°C; 5 to 95% RH
OT/H – Outside Plant	-40°C to 85°C; 5 to 95% RH				
Storage Temperature/Humidity	-40°C to 85°C; 5 to 95% RH				
Max. Input Power Rating	300 mW				
Optical Passband					
DWDM Channel Center Wavelength	per ITU 100 GHz Grid		per ITU 50 GHz Grid		
DWDM Channel Passband @ 0.5 dB	± 0.125 nm (ITU Channel Center Wavelength)		± 0.06 nm (ITU Channel Center Wavelength)		
DWDM Channel Passband Ripple	< 0.5				
Upgrade Port Optical Passband	1528.65 nm to 1566.44 nm				
Express Port Optical Passband	1260 nm to 1520 nm and 1570 nm to 1635 nm				
RX Test Optical Passband	1260 nm to 1635 nm				
TX Test Optical Passband	± 0.125 nm (ITU Channel Center Wavelength)		± 0.06 nm (ITU Channel Center Wavelength)		
Insertion Loss (New Product, 20°C to 25°C) ***					
Max IL (dB) – Common to DWDM Ch.	20 Ch	40 Ch	20 Ch	40 Ch	Commercial Spec LC Only
	4.0	4.0	4.0	4.0	
Max DWDM Channel Uniformity	2.0 dB				
Max IL (dB) – Common to Upgrade	3.55	3.5	3.5	3.5	3.0 dB **
Max IL – Common to Express	1.0 dB				
Common to RX Test	≤21.0 dB				
Express to TX Test	≤22.0 dB				
Isolation					
Min DWDM Adjacent Channel Isolation	30 dB		25 dB		
Min DWDM Non-Adjacent Ch. Isolation	45 dB		35 dB		
Min Express Isolation	12 dB				
Max Polarization Dependent Loss (PDL)	0.3 dB				0.25 dB
Max Polarization Mode Dispersion (PMD)	0.3 dB				0.15 dB
Directivity					
DWDM Port Min Directivity	50 dB				55 dB
Express Port Min Directivity	45 dB				
Test Port Min Directivity	50 dB				
Min Return Loss (all ports)	45 dB				
Insertion Loss Thermal Stability					
Insertion Loss Thermal Stability – New Prod.	≤0.005 dB/C				
Insertion Loss Thermal Stability – Service Life	≤0.010 dB/C				< 0.005 dB/C
Wavelength Thermal Stability	≤0.001 nm/C				
Rack Unit Size	1RU				

NOTES:

* Unless otherwise noted, optical specification applies across operating temperature and optical bandpass.

** Includes connector loss.

*** Unless noted, 0.40 dB per mated connector loss is EXCLUDED.

continued
→

Dense Wave Division Multiplexing (DWDM) Rack-Mount Panels

DWDM ITU Channels

CHANNEL NO.	FREQUENCY (GHz)	CENTER WAVELENGTH (nm)	CHANNEL NO.	FREQUENCY (GHz)	CENTER WAVELENGTH (nm)	CHANNEL NO.	FREQUENCY (GHz)	CENTER WAVELENGTH (nm)	CHANNEL NO.	FREQUENCY (GHz)	CENTER WAVELENGTH (nm)
C1	190,100	1577.03	C19	191,900	1562.23	C37	193,700	1547.72	C55	195,500	1533.47
H1	190,150	1576.61	H19	191,950	1561.83	H37	193,750	1547.32	H55	195,550	1533.07
C2	190,200	1576.20	C20	192,000	1561.42	C38	193,800	1546.92	C56	195,600	1532.68
H2	190,250	1575.78	H20	192,050	1561.01	H38	193,850	1546.52	H56	195,650	1532.29
C3	190,300	1575.37	C21	192,100	1560.61	C39	193,900	1546.12	C57	195,700	1531.90
H3	190,350	1574.95	H21	192,150	1560.20	H39	193,950	1545.72	H57	195,750	1531.51
C4	190,400	1574.54	C22	192,200	1559.79	C40	194,000	1545.32	C58	195,800	1531.12
H4	190,450	1574.13	H22	192,250	1559.39	H40	194,050	1544.92	H58	195,850	1530.72
C5	190,500	1573.71	C23	192,300	1558.98	C41	194,100	1544.53	C59	195,900	1530.33
H5	190,550	1573.30	H23	192,350	1558.58	H41	194,150	1544.13	H59	195,950	1529.94
C6	190,600	1572.89	C24	192,400	1558.17	C42	194,200	1543.73	C60	196,000	1529.55
H6	190,650	1572.48	H24	192,450	1557.77	H42	194,250	1543.33	H60	196,050	1529.16
C7	190,700	1572.06	C25	192,500	1557.36	C43	194,300	1542.94	C61	196,100	1528.77
H7	190,750	1571.65	H25	192,550	1556.96	H43	194,350	1542.54	H61	196,150	1528.38
C8	190,800	1571.24	C26	192,600	1556.56	C44	194,400	1542.14	C62	196,200	1527.99
H8	190,850	1570.83	H26	192,650	1556.15	H44	194,450	1541.75	H62	196,250	1527.60
C9	190,900	1570.42	C27	192,700	1555.75	C45	194,500	1541.35	C63	196,300	1527.22
H9	190,950	1570.01	H27	192,750	1555.34	H45	194,550	1540.95	H63	196,350	1526.83
C10	191,000	1569.59	C28	192,800	1554.94	C46	194,600	1540.56	C64	196,400	1526.44
H10	191,050	1569.18	H28	192,850	1554.54	H46	194,650	1540.16	H64	196,450	1526.05
C11	191,100	1568.77	C29	192,900	1554.13	C47	194,700	1539.77	C65	196,500	1525.66
H11	191,150	1568.36	H29	192,950	1553.73	H47	194,750	1539.37	H65	196,550	1525.27
C12	191,200	1567.95	C30	193,000	1553.33	C48	194,800	1538.98	C66	196,600	1524.89
H12	191,250	1567.54	H30	193,050	1552.93	H48	194,850	1538.58	H66	196,650	1524.50
C13	191,300	1567.13	C31	193,100	1552.52	C49	194,900	1538.19	C67	196,700	1524.11
H13	191,350	1566.72	H31	193,150	1552.12	H49	194,950	1537.79	H67	196,750	1523.72
C14	191,400	1566.31	C32	193,200	1551.72	C50	195,000	1537.40	C68	196,800	1523.34
H14	191,450	1565.90	H32	193,250	1551.32	H50	195,050	1537.00	H68	196,850	1522.95
C15	191,500	1565.50	C33	193,300	1550.92	C51	195,100	1536.61	C69	196,900	1522.56
H15	191,550	1565.09	H33	193,350	1550.52	H51	195,150	1536.22	H69	196,950	1522.18
C16	191,600	1564.68	C34	193,400	1550.12	C52	195,200	1535.82	C70	197,000	1521.79
H16	191,650	1564.27	H34	193,450	1549.72	H52	195,250	1535.43	H70	197,050	1521.40
C17	191,700	1563.86	C35	193,500	1549.32	C53	195,300	1535.04	C71	197,100	1521.02
H17	191,750	1563.45	H35	193,550	1548.91	H53	195,350	1534.64	H71	197,150	1520.63
C18	191,800	1563.05	C36	193,600	1548.52	C54	195,400	1534.25	C72	197,200	1520.25
H18	191,850	1562.64	H36	193,650	1548.11	H54	195,450	1533.86	H72	197,250	1519.86

NOTES:

1. See Channel column to determine frequency and center wavelength values.
2. 100 GHz channels begin Cxx and 50 GHz channels begin with Cxx or Hxx.
3. Channels C16 (1564.68 nm) through C63 (1527.22 nm) reference C-BAND filter passband.

Temperature Specifications *

	50 GHz & 100 GHz DWDM	COMMERCIAL SPEC VARIATION
Operation Temperature, Relative Humidity Inside Plant	-10°C to +65°C; 5 to 95% RH	-20°C to 65°C; 5 to 95% RH
Outside Plant	-40°C to 85°C; 5 to 95% RH	
Storage Temperature, Relative Humidity	-40°C to 85°C; 5 to 95% RH	

* Unless otherwise noted, optical specification applies across operating temperature and optical bandpass.

Contact AFL for further details.



RFOG WDM Module

The RFOG WDM module is designed to satisfy wavelength management requirements where 1310, 1490, 1550, 1590 / 1610 nm wavelengths are used in passive optical network applications. This unit is available in traditional LGX® module packaging with virtually all connector options supported. Also available is a high density platform delivering unsurpassed ports per rack unit for applications requiring the most efficient use of available rack space.

Features

- Flexible packaging options
- Low Excess Loss
- Low PDL
- Monitoring/Tap ports available

Applications

- PON – FTTx Networks
- Access Networks
- CATV Links

Specifications

PARAMETER	UNIT	SPECIFICATION		
		MIN	MAX	
Wavelength Range	1310 Band	nm	1270	1350
	1490 Band		1480	1500
	1550 Band		1540	1570
	1590/1610 Band		1584.5	1620
Insertion Loss	1310+1490 Port	dB	–	1.2
	1550 Port			1.4
	1590/1610 Port			1.5
Band Isolation	1310/1490 Port @ 1550	dB	40	
	1310/1490 Port @ 1590/1610		40	
	1550 Port @ 1310/1490		30	
	1550 Port @ 1590		15	
	1590/1610 Port @ 1310/1490/1550		35	
Wavelength Thermal Stability	nm/°C			0.002
Directivity	dB	50		
PDL	dB			0.15
PMD	ps			0.10
Return Loss	dB	45		
Optical Power Handling	mW	300		
Operation Humidity	% RH	5 ~ 95 not condensed		
Storage Humidity	% RH	0 ~ 95 not condensed		

Ordering Information

DESCRIPTION	AFL NO.
FILTER WDM, 1310+1490/1550+1590/1610,SC/APC	CM000150
DUAL FILTER WDM, 1310+1490/1550+1590/1610,LC/APC	CM000151

* Additional configuration available upon request. Contact AFL Customer Service.

Qualifications

GOVERNING BODY	STANDARD CODE
RoHS	Compliant

Temperature Specifications

TEMPERATURE RANGE	
Operation Temperature	-5°C to +70°C
Storage Temperature	-40°C to +85°C

Contact AFL for further details.



LGX® FTTx WDM Modules

The FTTx WDM Modules are designed to satisfy 1310, 1490 and 1550 nm wavelength management requirements in FTTx passive optical networks. Based on proven thin-film filter technology, these modules offer low overall insertions loss, high wavelength thermal stability and high band isolation, all of which add to network reliability. These products are available in LGX compatible modules of scaling density to meet varying density objectives.

Features

- Low excess loss
- Low polarization dependent loss
- Flexible LGX packaging options
(*see ordering information below for product size and density information)
- SC/APC Connectors

Applications

- PON - FTTx Networks
- Access Networks
- CATV Links
- Wide Area Networks

Performance Specifications

PARAMETER		UNIT	SPECIFICATION	
			MINIMUM	MAXIMUM
Wavelength Range	1310 Band	nm	1260	1360
	1490 Band	nm	1480	1500
	1550 Band	nm	1550	1560
Insertion Loss	1310+1490 Port	dB		1.2
	1550 Port	dB		1.4
Band Isolation	1310/1490 Port @ 1550	dB	40	
	1550 @ 1310/1490 Port	dB	30	
Wavelength Thermal Stability		nm/°C		0.002
Directivity		dB	50	
PDL		dB		0.15
PMD		ps		0.1
Return Loss		dB	45	
Optical Power Level		mW	300	
Operation Humidity		% RH	5 to 90	
Storage Humidity		% RH	0 to 95	

Ordering Information

DESCRIPTION	AFL NO.
PON WDM Module, 1X, 1310/1490+1550, Single slot LGX, Black, SC/APC	CM000478
PON WDM Module, 2X, 1310/1490+1550, Single slot LGX, Black, SC/APC	CM000479
PON WDM Module, 4X, 1310/1490+1550, Dual slot LGX, Black, SC/APC	CM000480
PON WDM Module, 6X, 1310/1490+1550, Triple slot LGX, Black, SC/APC	CM000481

Qualifications

GOVERNING BODY	STANDARD CODE
Telcordia	GR-1209, GR1221

Temperature Specifications

TEMPERATURE RANGE	
Operation Temperature	-5°C to +70°C
Storage Temperature	40°C to +85°C

LGX is a registered trademark of Furukawa Electric North America, Inc.
Telcordia is a registered trademark of Telcordia Technologies, Inc.

Contact AFL for further details.

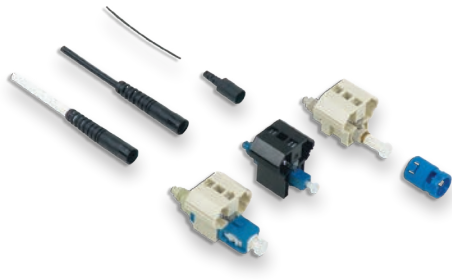

FASTConnect® Field-Installable Connectors

FASTConnect are factory pre-polished, field-installable connectors that completely eliminate the need for hand polishing in the field. Proven mechanical splice technology ensuring precision fiber alignment, a factory pre-cleaved fiber stub and a proprietary index-matching gel combine to offer an immediate low loss termination to either single-mode or multimode optical fibers. FASTConnect are compatible with 250 µm and 900 µm optical fibers, as well as 4.8 mm (SC only) cordage.

All primary fiber types are supported, and each connector is color coded per industry standard requirements to aid in identification during and after installation. A factory-installed wedge clip (included with each connector) is removed and discarded upon completion of the termination. Incorporated into this device is an innovative, translucent wedge enabling the use of a common VFI to provide a "pass/fail" signal once physical contact is achieved.

Features

- No epoxy, no Polish
- Low insertion loss
- Fiber can be reinserted up to three times
- 4.8 mm (SC only) cordage compatibility
- VFI accessory to confirm proper installation

Applications

- Premise/Enterprise Networks
- LAN/WAN Connections
- Patch Panels
- Equipment Termination
- FTTx Applications
- Field Repair/Replacement
- Equipment Test Leads

Specifications

PARAMETER	TYPE	VALUE
Insertion Loss:	Single-mode - UPC	Average: 0.2 dB, Maximum: 0.5 dB
	Single-mode - APC	Average: 0.3 dB, Maximum: 0.6 dB
	Multimode - PC	Average: 0.1 dB, Maximum: 0.5 dB
Return Loss at Room Temperature	Single-mode - UPC	Average: -50 dB, Maximum: -45 dB
	Single-mode - APC	Average: -55 dB, Maximum: -50 dB
	Multimode	Average: -25 dB, Maximum: -20 dB

Ordering Information

FIBER TYPE	HOUSING COLOR	CABLE SIZE	AFL NO.	
			PACKAGE OF 6	PACKAGE OF 100
FASTCONNECT SC				
Multimode 62.5/125 µm, OM1	Beige	900 µm	FAST-SC-MM62.5-6	FAST-SC-MM62.5-100
Multimode 50/125 µm, OM2	Black		FAST-SC-MM50-6	FAST-SC-MM50-100
Multimode 50/125 µm, OM3/OM4 compatible	Aqua		FAST-SC-MM50L-6	FAST-SC-MM50L-100
Single-mode, UPC	Blue		FAST-SC-SM-6	FAST-SC-SM-100
Single-mode, APC	Green		FAST-SC-SMAU-6	FAST-SC-SMAU-100
Single-mode, APC	Green	4.8 mm	FAST-SC48-SMAU-6	FAST-SC48-SMAU-100
FASTCONNECT ST				
Multimode 62.5/125 µm, OM1	Beige	900 µm	FAST-ST-MM62.5-6	FAST-ST-MM62.5-100
Multimode 50/125 µm, OM2	Black		FAST-ST-MM50-6	FAST-ST-MM50-100
Multimode 50/125 µm, OM3/OM4 compatible	Aqua		FAST-ST-MM50L-6	FAST-ST-MM50L-100
Single-mode, UPC	Blue		FAST-ST-SM-6	FAST-ST-SM-100
FASTCONNECT LC				
Multimode 62.5/125 µm, OM1	Beige	900 µm	FAST-LC-MM62.5-6	FAST-LC-MM62.5-100
Multimode 50/125 µm, OM2	Black		FAST-LC-MM50-6	FAST-LC-MM50-100
Multimode 50/125 µm, OM3/OM4 compatible	Aqua		FAST-LC-MM50L-6	FAST-LC-MM50L-100
Single-mode, UPC	Blue		FAST-LC-SM-6	FAST-LC-SM-100
Single-mode, APC	Green		FAST-LC-SMAU-6	FAST-LC-SMAU-100

continued
→

FASTConnect® Field-Installable Connectors

Accessories

DESCRIPTION			AFL NO.	AFL NO.
BOOT KITS FOR 2 MM AND 3 MM CORDAGE	COLOR	CABLE SIZE	PACK OF 6	PACK OF 100
2 mm Boot Kit, SC/LC/ST	Black	2 mm	FAST-BOOT-2MM-6	FAST-BOOT-2MM-100
3 mm Boot Kit, SC/LC/ST	Black	3 mm	FAST-BOOT-3MM-6	FAST-BOOT-3MM-100
DUPLEX CLIPS				
LC Duplex Clip (LC only)	Transparent		CS010437-06	CS010437-100
TOOL KITS				AFL NO.
FASTConnect High Precision Tool Kit with CT50 Cleaver				CS001201
FASTConnect High Precision Tool Kit with CT16 Cleaver				CS010975
VISUAL FAULT IDENTIFIERS				AFL NO.
VFI4 visual fault identifier with 2.5 mm and 1.25 mm adapters				VFI4-01-0900PR
2.5 mm Universal for VFI port				2900-50-0013MR
1.25 mm Universal for VFI port				2900-50-0012MR

Qualifications

GOVERNING BODY	STANDARD CODE
EIA/TIA	568-C.3 604 (FOCIS)

Temperature Specifications

TEMPERATURE RANGE	
Operating Temperature	-40°C to +75°C

Patents

COUNTRY	PATENT NUMBER(S)
U.S.	5,963,699 5,984,532 6,179,482 7,003,208 7,258,496

Contact AFL for further details.



FUSEConnect Connectors (SC, FC, LC, ST)

FUSEConnect® Fusion-Spliced, Field-Installable Connectors

AFL's FUSEConnect fusion-spliced, field installable connectors are uniquely designed and feature only four to five components. The factory pre-polished ferrule eliminates the need for polishing, adhesives, and crimping in the field, which minimizes the potential for operator error and expensive connector scrap.

FUSEConnect utilizes a fusion splicer to terminate the connector in the field, addressing return loss concerns present in analog optical networks. This advanced process yields true APC performance for SC/APC and LC/APC configurations. FUSEConnect is compatible with Fujikura fusion splicers and most other fiber holder-based fusion splicing platforms.

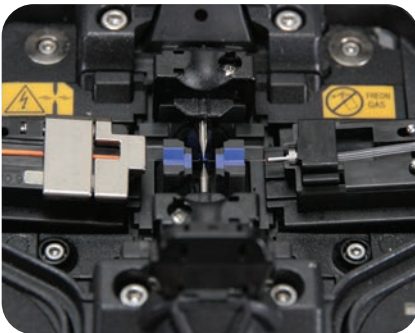

FUSEConnect in Fusion Splicer

Features

- Field installable
- No adhesives, crimping or polishing
- True APC performance
- Compatible with most fusion splicers

Applications

- Connectorization in:
 - RF-overlay FTTP networks
 - Cable TV backbone networks
 - Outside plant
 - FTTD
 - MDU FTTP Cabling
- Central office connector replacement
- Data center installation

Specifications

PARAMETER	VALUE
Connector Type	SC, LC, FC, ST
Cable Type	900 μm, 2 mm, 3 mm, 4.8 mm (SC only)
Polish	APC, UPC, PC
Insertion Loss	SM: 0.15 dB (average), 0.25 dB (maximum) / MM: 0.10 dB (average), 0.25 dB (maximum)
Return Loss	SM: ≤ -65 dB (APC), ≤ -55 dB (UPC) / MM: ≤ -35 dB (PC)

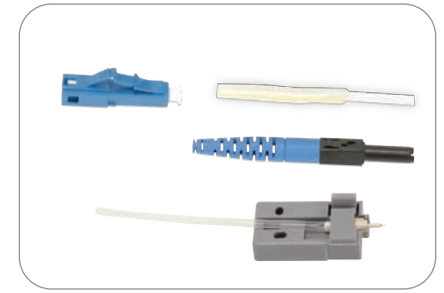
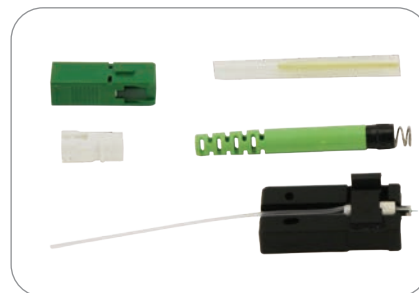
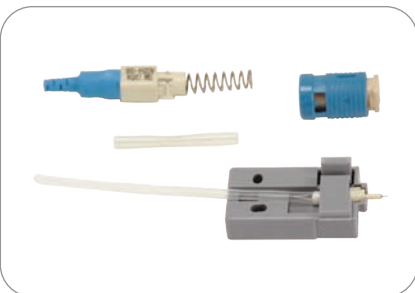

FUSEConnect Kits—ST (blue), SC (green), LC (blue)

continued
→

FUSEConnect® Fusion-Spliced, Field-Installable Connectors

Ordering Information

CONNECTOR TYPE	BOOT TYPE	AFL NO.*				
		UPC SM (Blue)	APC SM (Green)	PC 62.5 µm MM (Beige)	PC 50 µm MM (Black)	PC 50 µm LOMMF (AQUA) **
SC	900 µm	FUSE-SC9SMU-6	FUSE-SC9SMA-6	FUSE-SC9M62-6	FUSE-SC9M50-6	FUSE-SC9M50L-6
	3 mm	FUSE-SC3SMU-6	FUSE-SC3SMA-6	FUSE-SC3M62-6	FUSE-SC3M50-6	FUSE-SC3M50L-6
	4.8 mm	—	FUSE-SC48SMA-6	—	—	—
LC	900 µm	FUSE-LC9SMU-6	FUSE-LC9SMA-6	FUSE-LC9M62-6	FUSE-LC9M50-6	FUSE-LC9M50L-6
	2 mm	FUSE-LC2SMU-6	FUSE-LC2SMA-6	FUSE-LC2M62-6	FUSE-LC2M50-6	FUSE-LC2M50L-6
FC	900 µm	FUSE-FC9SMU-6	FUSE-FC9SMA-6	FUSE-FC9M62-6	FUSE-FC9M50-6	FUSE-FC9M50L-6
	2 mm	FUSE-FC2SMU-6	—	FUSE-FC2M62-6	FUSE-FC2M50-6	FUSE-FC2M50L-6
	3 mm	FUSE-FC3SMU-6	—	FUSE-FC3M62-6	FUSE-FC3M50-6	FUSE-FC3M50L-6
ST	900 µm	FUSE-ST9SMU-6	—	FUSE-ST9M62-6	FUSE-ST9M50-6	FUSE-ST9M50L-6
	2 mm	FUSE-ST2SMU-6	—	FUSE-ST2M62-6	FUSE-ST2M50-6	FUSE-ST2M50L-6
	3 mm	FUSE-ST3SMU-6	—	FUSE-ST3M62-6	FUSE-ST3M50-6	FUSE-ST3M50L-6

* AFL NO. is for one pack of 6 pieces

** Laser Optimized MM Fiber (LOMMF) compatible with OM3 and OM4 fibers

Temperature Specifications

TEMPERATURE RANGE	
Operating Temperature	-40°C to +75°C

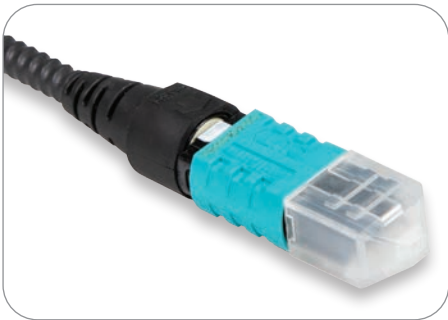

FUSEConnect MPO Connectors, Cable



FUSEConnect MPO Connectors, Ribbon

FUSEConnect® MPO Splice-On, Field-Installable Connectors with Heat Sleeve

AFL's FUSEConnect MPO splice-on, field-installable connectors are uniquely designed and feature just six components. The innovative factory pre-polished ferrule allows for a field-termination process that eliminates the need for polishing, adhesives and crimping in the field and minimizes the potential for operator error and expensive connector scrap. FUSEConnect MPO is part of the FUSEConnect splice-on connector family which includes SC, LC, ST and FC style connectors.

This updated design for the FUSEConnect MPO replaces the mechanical clamp splice protector with a heat protection sleeve utilizing the on-board splicer heater eliminating the need for a separate mechanical clamp tool. The connector is designed for use with the new RT-02 ribbonizing tool which does not require ribbonizing glue resulting in a cleaner termination process.

FUSEConnect MPO performs as an equivalent to the standard factory terminated MPO/MTP® assemblies. Designed to utilize standard ribbon, SpiderWeb Ribbon®, or loose tube cable, this connector helps minimize the complexity involved in the termination of a multi-fiber connection, allowing for a reliable and repeatable termination in field applications. AFL offers a tool kit as well as a variety of accessories designed to meet all your installation needs for your FUSEConnect MPO application.

Features

- Field installable splice-on connector
- Heat sleeve style splice protector
- Utilizes RT-02 ribbonizing tool for glueless termination process
- Only six components
- No adhesives, crimping or polishing
- Field MPO polarity customization
- Includes 3.0 mm round and flat ribbon boots in each pack

Applications

- Connectorization in:
 - RF-overlay FTTP networks
 - Cable TV backbone networks
 - Outside plant
 - MDU FTTP Cabling
- Connector restoration in the field
- Data center installation
- Patch cord customization in the field

Specifications

PARAMETER		VALUE
Insertion Loss	Single-mode (OS1)	Average: 0.25 dB; Max: 0.75 dB
	Single-mode (OS1), Low Loss	Average: 0.10 dB; Max: 0.35 dB
	62.5/125 (OM1)	Average: 0.10 dB; Max: 0.35 dB
	50/125 (OM4)	Average: 0.10 dB; Max: 0.35 dB
Return Loss	Single-mode (OS1)	>65 dB
	62.5/125 (OM1)	>30 dB
	50/125 (OM4)	>30 dB

continued
→

FUSEConnect® MPO Splice-On, Field-Installable Connectors with Heat Sleeve

Ordering Information

AFL NO.*	CONNECTOR TYPE	FIBER TYPE	POLISH	CABLE SIZE		HOUSING COLOR
				ROUND	FLAT	
FUSEMPO-S-SMA-3-F-6	MPO, Female (No Guide Pins)	Single-mode (OS1)	APC	3.0 mm	250 µm	Green
FUSEMPO-S-SMA-3-M-6	MPO, Male (Guide Pins)	Single-mode (OS1)	APC	3.0 mm	250 µm	Green
FUSEMPO-S-LSMA-3-F-6	MPO, Female (No Guide Pins)	Single-mode (OS1), Low Loss	APC	3.0 mm	250 µm	Mustard
FUSEMPO-S-LSMA-3-M-6	MPO, Male (Guide Pins)	Single-mode (OS1), Low Loss	APC	3.0 mm	250 µm	Mustard
FUSEMPO-S-MM6-3-F-6	MPO, Female (No Guide Pins)	Multimode 62.5 µm (OM1)	PC	3.0 mm	250 µm	Beige
FUSEMPO-S-MM6-3-M-6	MPO, Male (Guide Pins)	Multimode 62.5 µm (OM1)	PC	3.0 mm	250 µm	Beige
FUSEMPO-S-OM4-3-F-6	MPO, Female (No Guide Pins)	Multimode , 50 µm (OM4)	PC	3.0 mm	250 µm	Aqua
FUSEMPO-S-OM4-3-M-6	MPO, Male (Guide Pins)	Multimode , 50 µm (OM4)	PC	3.0 mm	250 µm	Aqua

*Pack of 6 pieces

Ordering Information – Accessories

DESCRIPTION	AFL NO.
TOOL KIT	
FUSEConnect MPO Tool Kit	FUSEMPO-TL-KT
ACCESSORIES	
FUSEConnect Stripping Tool (3.0 mm, 2.8 mm, 2.0 mm and 1.6 mm)	FUSE-ST-TL
FUSEConnect MPO Heater Attachment Tool	FUSE-HT-TL
MPO Boot Kit for 3.8 mm diameter cable (Pack of 144)	FUSEMPO-BOOT-3.8MM-144
MPO Boot Kit for Jacketed Ribbon (Pack of 6)	FUSEMPO-BOOT-JK-6

Temperature Specifications

TEMPERATURE RANGE	
Operating Temperature	-40°C to +75°C

Qualifications

GOVERNING BODY	STANDARD CODE
TIA	604-5-C
IEC	61754-7
EIA/TIA	568-C.3
FOCIS	FOCIS-5

Contact AFL for further details.



Tool Kit Contents

FASTConnect® Universal Tool Kit

Now available with the CT50 or CT16 Cleaver!

The FASTConnect Universal Tool Kits provide all the necessary installation tools required for fiber preparation of 250 μm or 900 μm fibers, or 900 μm, 2 mm or 3 mm cordage for AFL's pre-polished FASTConnect. Featuring either the CT50 or CT16 fiber cleaver, the FASTConnect Universal Tool Kit contains all the industry standard termination tools required for fiber preparation. Additionally, the carrying case has adequate storage for extra FASTConnects for on-site convenience.

Kit Features

- Industry standard fiber preparation tools
- Compact design, flexible yet rugged case
- Complete instructions provided

Applications

- Premise environments
- LAN Fiber to the Desk environments
- Patch panel/wiring closets
- FTTx applications
- Quick repair/replacement areas



CT50 Cleaver

Ordering Information

DESCRIPTION	AFL NO.
FASTConnect High Precision Tool Kit with CT50 Cleaver	CS001201
FASTConnect High Precision Tool Kit without cleaver	CS001201-NC
FASTConnect High Precision Tool Kit with CT16 Cleaver	CS010975

Tool Kits include: Cleaver, FAST Assembly Tool, 3 mm Cable Clamp, 2 mm Cable Clamp, 0.25/0.9 mm Cable Clamp, Fiber Stripper, Kevlar Scissors, Fiber Preparation Fluid, Lint-free Cloth Wipes, Marker Pen, Installation Instructions, Strip Length Template and a Carrying Case.



CT16 Cleaver

CT50 Cleaver Features

- Motorized blade rotation
- Bluetooth communication
- Shock resistant
- Simple one-step operation
- 60,000 cleave blade life
- Field serviceable

CT16 Cleaver Features

- Dual fiber adapter plate for single or two fiber cleaving
- Ambidextrous operation available
- Field replaceable fiber clamp pads and cleaver blade
- Shock resistant for drops up to 30" in any of six different orientations
- Compact form factor and tool-less blade rotations



FUSEConnect Tool Kit Contents



FUSEConnect Accessory Kit



Cord Splitter Tool

FUSEConnect® Tool Kit and Accessories

The FUSEConnect tool kit provides all the necessary installation tools required for fiber preparation of 900 μm fiber, 2 mm or 3 mm cordage for AFL's FUSEConnect Fusion Spliced Field Installable Connectors except for a fusion splicer and precision cleaver. Included in the kit are standard fiber preparation tools and cleaning supplies as well as a FUSEConnect accessory kit and cord splitter tool, which can be bought separately from the tool kit. The cord splitter tool is uniquely designed to open the cordage of 2 mm and 3 mm cable allowing the termination of the ST and FC type connectors on simplex cordage.

Features

- Industry standard fiber preparation tools
- Compact design, flexible yet rugged case

Applications

- Premise environments
- LAN Fiber to the Desk environments
- Patch panel/wiring closets
- FTtx applications
- Quick repair/replacement areas

Ordering Information

DESCRIPTION	AFL NO.
FUSECONNECT TOOL KIT (INCLUDES ITEMS BELOW)	FUSE-TL-KT
Tool Case	CS001202
Fiber Stripper	CS001205
Kevlar Scissors	C095257
Lint-Free Wipes	FM000413
Fiber Preparation Fluid	PPF1-00-0900
Permanent Marker	C015830
Cord Splitter Tool	FUSE-ST-TL
FUSEConnect Accessory Kit	FUSE-AC-KT

FUSEConnect Accessory Kit (includes items below)	FUSE-AC-KT
Utility Storage Box	CS012351
Clamp for holding 3 mm Simplex Cordage	S014704
Clamp for holding 2 mm Simplex Cordage	S014705
250 μm / 900 μm Fiber Clamp	CS004442
3 mm FUSEConnect Fiber Holder	S014695
2 mm FUSEConnect Fiber Holder	S014696
900 μm FUSEConnect Fiber Holder	S014697
CLAMP-S70D Sheath Clamp	S015862
CLAMP-S31B Sheath Clamp	S017101

Cord Splitter Tool	FUSE-ST-TL
---------------------------	-------------------

Legacy Splicer Accessories (Required for Fanout Splicing)	
CLAMP-S21B Sheath Clamp	S016853
CLAMP-S60D Sheath Clamp	S014750

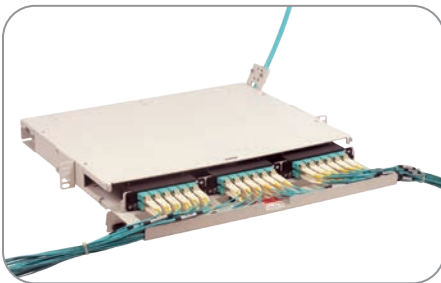

LightLink LANSystem 1RU Fiber Termination Patch/Splice Panel

The AFL 1RU Fiber Termination Patch/Splice Panel is designed for use as a rack mount interconnect point where termination and connectivity of up to 36 fibers is desired. The panel design is based on a 1 rack unit height and is provisioned with three LGX® 118 compatible mounting positions that can accommodate adapter plates, XFM® optical cassettes, passive optical modules or any combination therein.

Standard 1RU Fiber Termination Patch Panels are available empty for complete field configuration, half loaded with adapter plates, or stubbed with a factory installed circular premise cable (CPC) or loose tube cable assembly.

Standard 1RU Fiber Patch and Splice Panels are available empty for complete field configuration, half loaded with adapter plates and splice trays, or loaded with pigtails, adapter plates and splice trays.

Features

- Fits comfortably into new and existing interconnect, cross-connect, customer premise, and co-location environments
- Most common connector styles and types available
- Compatible with industry standard equipment frames
- Modular design
- Slide-out tray with relief cut-outs for simplified connector access
- Optional splice tray kit for on site conversion to patch and splice panel
- Optional front door key lock for heightened protection of internal components

Applications

- Telecommunications closets
- Data Centers
- Customer Premise
- LAN / WAN Networks
- Central Offices / Headends
- Hubs / Cabinets / Remote Terminals
- FTTH / FTTB Networks

Specifications

- Designed around Telcordia® GR-63NEBS
- Aluminum construction per ASTMB209
- Durable textured powder coat finish available in black or white
- Universal 19/23" EIA/TIA rack compatibility
- Standard density: up to 18-fiber
- High density: up to 36-fiber
- LGX 118 compatible
- Standard cable stub location is right rear exiting upward
- 1RU Patch and Splice Panel holds up to three splice tray kits

Dimensions

DEPTH (A) IN INCHES	WIDTH (B) IN INCHES	HEIGHT (C) IN INCHES	RACK UNITS	CAPACITY	UNLOADED WEIGHT
13.51	17.00	1.75	1	18 / 36	4 lbs.

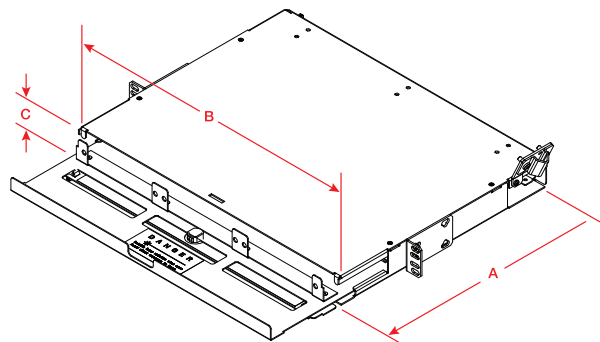

LGX is a registered trademark of Furukawa Electric North America, Inc.
Telcordia is a registered trademark of Telcordia Technologies, Inc.

LightLink LANSystem 1RU Fiber Termination Patch/Splice Panel

Ordering Information

Select the seven digit AFL panel part number, specify the color, and choose the loading character desired.

When ordering stubbed (S), enter the cable stub length required in meters.

Note: Standard stub is Circular Premise Cable (CPC).

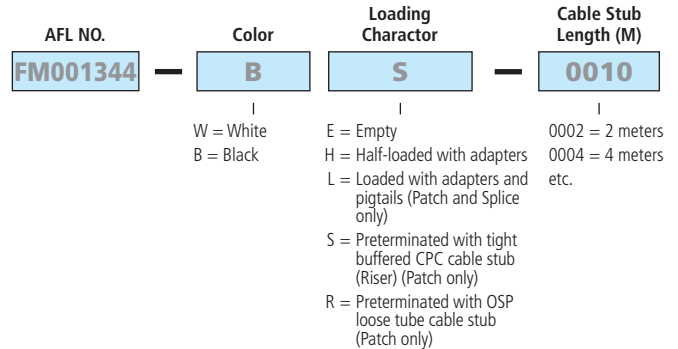

Example: Order number for a panel Black in color, loaded with 12 PSC adapters (2 six packs), connectors and a cable stub 10 meters in length.

Ordering Information

CONFIGURATION	AFL NO.
CON012P—1 RU PATCH PANELS—12 FIBERS—LGX118	
EMPTY	FM001038
12 PSC adapters (2 Six Packs)	FM001344
12 UST adapters (2 Six Packs)	FM001346
12 PST adapters (2 Six Packs)	FM001347
6 UDL (dup) adapters (2 Three Packs)	FM001353
6 PDL (dup) adapters (2 Three Packs)	FM001354
12 ASC adapters (2 Six Packs)	FM001352
12 UFC adapters (2 Six Packs)	FM001349
12 USC adapters (2 Six Packs)	FM001351
12 AFC adapters (2 Six Packs)	FM001350
CON024HD—1 RU HIGH DENSITY PATCH PANELS—24 FIBERS—LGX118	
24 UST adapters (2 Twelve Packs)	FM001355
24 PST adapters (2 Twelve Packs)	FM001356
12 PDL (dup) adapters (2 Six Packs)	FM001348
12 USF (dup) adapters (2 Six Packs)	FM001357
12 ASF (dup) adapters (2 Six Packs)	FM001358

CONFIGURATION	AFL NO.
CNS012P—1RU PATCH AND SPLICE PANELS—12 FIBERS—LGX118	
EMPTY	FM001328
12 PSC adapters (2 Six Packs), Splice Tray	FM001323
12 UST adapters (2 Six Packs), Splice Tray	FM001329
12 PST adapters (2 Six Packs), Splice Tray	FM001325
6 UDL (dup) adapters (2 Three Packs), Splice Tray	FM001334
6 PDL (dup) adapters (2 Three Packs), Splice Tray	FM001335
12 ASC adapters (2 Six Packs), Splice Tray	FM001333
12 UFC adapters (2 Six Packs), Splice Tray	FM001330
12 USC adapters (2 Six Packs), Splice Tray	FM001332
12 AFC adapters (2 Six Packs), Splice Tray	FM001331
CNS024HD—1 RU HIGH-DENSITY PATCH & SPLICE PANELS—24 FIBERS—LGX118	
24 UST adapters (2 Twelve Packs), Splice Tray	FM001336
24 PST adapters (2 Twelve Packs), Splice Tray	FM001337
12 USF (dup) adapters (2 Six Packs), Splice Tray	FM001338
12 ASF (dup) adapters (2 Six Packs), Splice Tray	FM001339

Qualifications

GOVERNING BODY	STANDARD CODE
ASTM	ASTMB209
Telcordia	GR-63NEBS

Accessories

DESCRIPTION	AFL NO.
Splice Tray Kit: Single Fusion, 12 fiber, 1RU Patch Panel Standard Density (1 splice tray)	FM002826-1
Splice Tray Kit: Single Fusion, 12 fiber, 1RU Patch Panel High Density (2 splice trays)	FM002826-2
Ribbon Splice Tray Kit: Mass Fusion, 12 fiber, 1RU Patch Panel Standard Density (1 splice tray)	FM002826-1R
Ribbon Splice Tray Kit: Mass Fusion, 12 fiber, 1RU Patch Panel High Density (2 splice trays)	FM002826-2R
Kit, Lock, for CON/CNS Panels	FM001318

Connector/Adapter Key

TYPE	DESCRIPTION
ASC	SC—Angle Polish, Simplex, SM
ASF	SC—Angle Polish, Duplex, SM
PSC	SC—Physical Polish, Simplex, MM
PSF	SC—Physical Polish, Duplex, MM
USC	SC—Ultra Polish, Simplex, SM
USF	SC—Ultra Polish, Duplex, SM
PST	ST—Physical Polish, Simplex, MM
UST	ST—Ultra Polish, Simplex, SM
AFC	FC—Angle Polish, Simplex, SM
PFC	FC—Physical Polish, Simplex, MM
UFC	FC—Ultra Polish, Simplex, SM
ADL	LC—Angle Polish, Duplex, SM
PLC	LC—Physical Polish, Simplex, MM
PDL	LC—Physical Polish, Duplex, MM
ULC	LC—Ultra Polish, Simplex, SM
UDL	LC—Ultra Polish, Duplex, SM

Notes:

- 1) All MM cable is 62.5 μm unless otherwise specified.
- 2) When ordering Empty Termination Patch/Splice Panel, accessories are available for field configuration.



LightLink LANSystem 2RU Fiber Termination Patch/Splice Panel

The AFL 2RU Fiber Termination Patch/Splice Panel is designed for use as a rack mount interconnect point where termination and connectivity of up to 72 fibers is desired. The panel design is based on a 2 rack unit height and is provisioned with three LGX® 118 compatible mounting positions that can accommodate adapter plates, XFM optical cassettes, passive optical modules or any combination therein.

Standard 2RU Fiber Termination Patch Panels are available empty for complete field configuration, half loaded with adapter plates, or stubbed with a factory installed circular premise cable (CPC) or loose tube cable assembly.

Standard 2RU Fiber Patch and Splice Panels are available empty for complete field configuration, half loaded with adapter plates and splice trays, or loaded with pigtails, adapter plates and splice trays.

Specifications

- Designed around Telcordia® GR-63NEBS
- Aluminum construction per ASTM B209
- Durable textured powder coat finish available in black or white
- Universal 19/23" EIA/TIA rack compatibility
- Standard density: up to 36 fiber
- High density: up to 72 fiber
- LGX 118 compatible
- Standard cable stub location is right rear exiting upward
- 2RU Patch and Splice Panel holds up to four splice tray kits

Features

- Fits comfortably into new and existing interconnect, cross-connect, customer premise, and co-location environments
- Most common connector styles and types available
- Compatible with industry standard equipment frames
- Modular design
- Slide-out tray with relief cut-outs for simplified connector access
- Optional splice tray kit for on site conversion to patch and splice panel
- Optional front door key lock for height-ened protection of internal components

Applications

- Telecommunications closets
- Data Centers
- Customer Premise
- LAN / WAN Networks
- Central Offices / Headends
- Hubs / Cabinets / Remote Terminals
- FTTH / FTTB Networks

Dimensions

DEPTH (A) IN INCHES	WIDTH (B) IN INCHES	HEIGHT(C) IN INCHES	RACK UNITS	CAPACITY	UNLOADED WEIGHT
13.51	17.00	3.50	2	36 / 72*	5 lbs.

* 72 fiber capacity not available in Patch and Splice configuration.

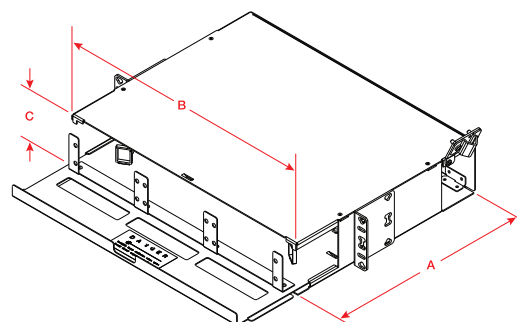

LGX is a registered trademark of Furukawa Electric North America, Inc.
Telcordia is a registered trademark of Telcordia Technologies, Inc.

LightLink LANSystem 2RU Fiber Termination Patch/Splice Panel

Ordering Information

Select the seven digit AFL panel part number, specify the color, and choose the loading character desired.

When ordering stubbed (S), enter the cable stub length required in meters.

Note: Standard stub is Circular Premise Cable (CPC).

AFL NO.	Color	Loading Character	Cable Stub Length (M)
FM001433	B	S	0010
	W = White B = Black	E = Empty H = Half-loaded with adapters L = Loaded with adapters and pigtails (Patch and Splice only) S = Preterminated with tight buffered CPC cable stub (Riser) (Patch only) R = Preterminated with OSP loose tube cable stub (Patch only)	0002 = 2 meters 0004 = 4 meters etc.

Example: Order number for a panel Black in color, loaded with 24 PSC adapters (4 six packs), connectors and a cable stub 10 meters in length.

Ordering Information

CONFIGURATION	AFL NO.
CON024P—2 RU PATCH PANELS—24 FIBERS—LGX118	
EMPTY	FM001029
24 PSC adapters (4 Six Packs) 118 LGX (Beige)	FM001433
24 UST adapters (4 Six Packs) 118 LGX	FM001434
24 PST adapters (4 Six Packs) 118 LGX	FM001435
12 UDL (dup) adapters (4 Three Packs) 118 LGX (Blue)	FM001441
12 PDL (dup) adapters (4 Three Packs) 118 LGX (Beige)	FM001442
24 ASC adapters (4 Six Packs) 118 LGX (Green)	FM001439
24 UFC adapters (4 Six Packs) 118 LGX	FM001436
24 USC adapters (4 Six Packs) 118 LGX (Blue)	FM001438
24 AFC adapters (4 Six Packs) 118 LGX	FM001437

CONFIGURATION	AFL NO.
CNS024P—2U PATCH AND SPLICE PANELS—24 FIBERS—LGX118	
EMPTY	FM001414
24 PSC adapters (4 Six Packs) 118 LGX, Splice tray	FM001411
24 UST adapters (4 Six Packs) 118 LGX, Splice tray	FM001412
24 PST adapters (4 Six Packs) 118 LGX, Splice tray	FM001413
12 UDL (dup) adapters (4 three Packs) 118 LGX , Splice tray	FM001419
12 PDL (dup) adapters (4 three Packs) 118 LGX , Splice tray	FM001420
24 ASC adapters (4 Six Packs) 118 LGX, Splice tray	FM001418
24 UFC adapters (4 Six Packs) 118 LGX, Splice tray	FM001415
24 USC adapters (4 Six Packs) 118 LGX, Splice tray	FM001417
24 AFC adapters (4 Six Packs) 118 LGX, Splice tray	FM001416

Notes:
 1) All MM cable is 62.5 μm unless otherwise specified.
 2) When ordering Empty Termination Patch/Splice Panel, accessories are available for field configuration.

Qualifications

GOVERNING BODY	STANDARD CODE
ASTM	ASTMB209
Telcordia	GR-63NEBS

Accessories

DESCRIPTION	AFL NO.
Splice Tray Kit: Single Fusion, 12 fiber, 2RU, WME02, WME04 (1 splice tray)	FM002827-1
Splice Tray Kit: Single Fusion, 12 fiber, 2RU, WME02, WME04 (2 splice trays)	FM002827-2
Splice Tray Kit: Single Fusion, 12 fiber, 2RU, WME02, WME04 (3 splice trays)	FM002827-3
Splice Tray Kit: Single Fusion, 12 fiber, 2RU, WME02, WME04 (4 splice trays)	FM002827-4
Splice Tray Kit: Single Fusion, 12 fiber, 2RU, WME02, WME04, Ribbon (1 splice tray)	FM002827-1R
Splice Tray Kit: Single Fusion, 12 fiber, 2RU, WME02, WME04, Ribbon (2 splice trays)	FM002827-2R
Splice Tray Kit: Single Fusion, 12 fiber, 2RU, WME02, WME04, Ribbon (3 splice trays)	FM002827-3R
Splice Tray Kit: Single Fusion, 12 fiber, 2RU, WME02, WME04, Ribbon (4 splice trays)	FM002827-4R
Kit, Lock, for CON / CNS Panels	FM001318

Connector/Adapter Key

TYPE	DESCRIPTION
ASC	SC—Angle Polish, Simplex, SM
ASF	SC—Angle Polish, Duplex, SM
PSC	SC—Physical Polish, Simplex, MM
PSF	SC—Physical Polish, Duplex, MM
USC	SC—Ultra Polish, Simplex, SM
USF	SC—Ultra Polish, Duplex, SM
PST	ST—Physical Polish, Simplex, MM
UST	ST—Ultra Polish, Simplex, SM
AFC	FC—Angle Polish, Simplex, SM
PFC	FC—Physical Polish, Simplex, MM
UFC	FC—Ultra Polish, Simplex, SM
ADL	LC—Angle Polish, Duplex, SM
PLC	LC—Physical Polish, Simplex, MM
PDL	LC—Physical Polish, Duplex, MM
ULC	LC—Ultra Polish, Simplex, SM
UDL	LC—Ultra Polish, Duplex, SM



LightLink LANSystem 3RU Fiber Termination Patch Panel

The AFL 3RU Fiber Termination Patch Panel is designed for use as a rack mount interconnect point where termination and connectivity of up to 96 fibers is desired. The panel design is based on a 3 rack unit height with a master plate that is provisioned with nine LGX® 118 compatible mounting positions that can accommodate adapter plates, XFM® optical cassettes, passive optical modules or any combination therein.

Standard 3RU Fiber Termination Patch Panels are available empty for complete field configuration, half loaded with adapter plates, or stubbed with a factory installed circular premise cable (CPC) or loose tube cable assembly.

Specifications

- Telcordia® GR-63 NEBS Tested
- Aluminum construction per ASTM B209
- Durable textured powder coat finish available in black or white
- Universal 19/23" EIA/TIA rack compatibility
- Standard density: up to 48-fiber
- High density: up to 96-fiber
- LGX 118 compatible
- Standard cable stub location is right rear exiting upward

Features

- Fits comfortably into new and existing interconnect, cross-connect, customer premise, and co-location environments
- Most common connector styles and types available
- Compatible with industry standard equipment frames
- LGX compatible master plate (118 mm)
- Modular design
- Provides maximum protection of optical components

Applications

- Telecommunications closets
- Data Centers
- Customer Premise
- LAN / WAN Networks
- Central Offices / Headends
- Hubs / Cabinets / Remote Terminals
- FTTH / FTTB Networks

Dimensions

DEPTH (A) IN INCHES	WIDTH (B) IN INCHES	HEIGHT (C) IN INCHES	RACK UNITS	FIBER CAPACITY	UNLOADED WEIGHT	MATERIAL GAUGE
11.00	17.00	5.25	3	48/96	8.4 lbs.	2.03 mm

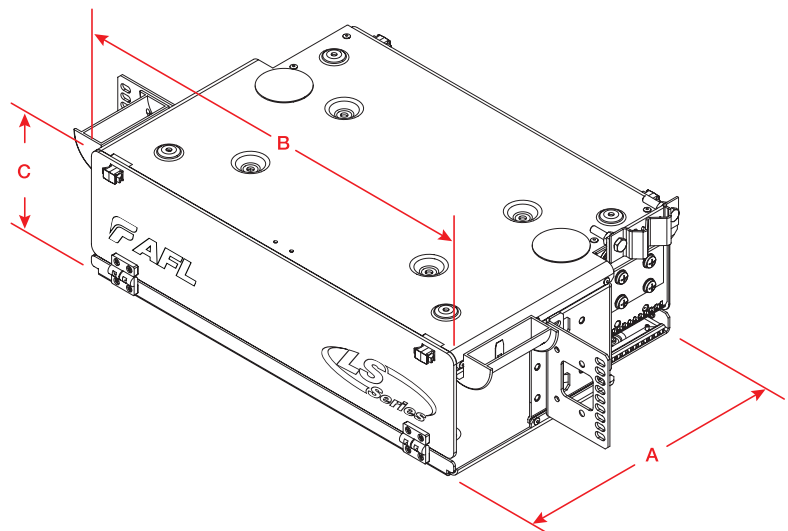

LGX is a registered trademark of Furukawa Electric North America, Inc.
Telcordia is a registered trademark of Telcordia Technologies, Inc.

LightLink LANSystem 3RU Fiber Termination Patch Panel

Ordering Information

Select the seven digit AFL part number you need, specify black or white, and choose the loading character desired.

When ordering stubbed (S), enter the cable stub length required in meters.

Note: Standard stub is Circular Premise Cable (CPC).

AFL NO.	Color	Loading Character	Cable Stub Length (M)
C211309	B	S	0010
	W = White B = Black	E = Empty H = Half-loaded with adapters S = Preterminated with tight buffered CPC cable stub (Riser) (Patch only) R = Preterminated with OSP loose tube cable stub (Patch only)	0002 = 2 meters 0004 = 4 meters etc.

Example: Order number for a panel Black in color, loaded with 48 PSC adapters (8 six packs), connectors and a cable stub 10 meters in length.

Configuration Part Numbers

All cable clamps offered separately so that customers may choose the correct clamp for their application.

CONFIGURATION	AFL NO.
CON048P—3 RU PATCH PANELS—48 FIBERS—LGX118	
EMPTY	C211291
48 PSC adapters (8 Six Packs)	C211309
48 UST adapters (8 Six Packs)	C211336
48 PST adapters (8 Six Packs)	C211345
24 UDL (dup) adapters (8 Three Packs)	FM000181
24 PDL (dup) adapters (8 Three Packs)	FM000182
48 ASC adapters (8 Six Packs)	C213928
48 UFC adapters (8 Six Packs)	C213916
48 USC adapters (8 Six Packs)	C213923
48 AFC adapters (8 Six Packs)	C213919
24 PSF (dup) adapters (8 Three Packs)	FM000183
24 USF (dup) adapters (8 Three Packs)	FM000184
24 ASF (dup) adapters (8 Three Packs)	FM000185
CON096HD—3 RU HIGH DENSITY PATCH PANELS—96 FIBERS—LGX118	
96 UST adapters (8 Twelve Packs)	FM000187
96 PST adapters (8 Twelve Packs)	FM000188
48 UDL (dup) adapters (8 Six Packs)	C211349
48 PSF (dup) adapters (8 Six Packs)	C211313
48 PDL (dup) adapters (8 Six Packs)	C211360
48 USF (dup) adapters (8 Six Packs)	FM000189
48 ASF (dup) adapters (8 Six Packs)	FM000190

Notes:

- 1) All MM cable is 62.5 µm unless otherwise specified.
- 2) When ordering Empty Termination Patch/Splice Panel, accessories are available for field configuration.

Qualifications

GOVERNING BODY	STANDARD CODE
ASTM	ASTMB209
Telcordia	GR-63NEBS

Connector/Adapter Key

TYPE	DESCRIPTION
ASC	SC—Angle Polish, Simplex, SM
ASF	SC—Angle Polish, Duplex, SM
PSC	SC—Physical Polish, Simplex, MM
PSF	SC—Physical Polish, Duplex, MM
USC	SC—Ultra Polish, Simplex, SM
USF	SC—Ultra Polish, Duplex, SM
PST	ST—Physical Polish, Simplex, MM
UST	ST—Ultra Polish, Simplex, SM
AFC	FC—Angle Polish, Simplex, SM
PFC	FC—Physical Polish, Simplex, MM
UFC	FC—Ultra Polish, Simplex, SM
ADL	LC—Angle Polish, Duplex, SM
PLC	LC—Physical Polish, Simplex, MM
PDL	LC—Physical Polish, Duplex, MM
ULC	LC—Ultra Polish, Simplex, SM
UDL	LC—Ultra Polish, Duplex, SM



LightLink LANSystem 4RU Fiber Termination Patch Panel

The AFL 4RU Fiber Termination Patch Panel is designed for use as a rack mount interconnect point where termination and connectivity of up to 144 fibers is desired. The panel design is based on a 4 rack unit height with a master plate that is provisioned with 12 LGX® 118 compatible mounting positions that can accommodate adapter plates, XFM® optical cassettes, passive optical modules or any combination therein.

Standard 4RU Fiber Termination Patch Panels are available empty for complete field configuration, half loaded with adapter plates, or stubbed with a factory installed circular premise cable (CPC) or loose tube cable assembly.

Specifications

- Telcordia® GR-63 NEBS Tested
- Aluminum construction per ASTM B209
- Durable textured powder coat finish available in black or white
- Universal 19/23" EIA/TIA rack compatibility
- Standard density: up to 72-fiber
- High density: up to 144-fiber
- LGX 118 compatible
- Standard cable stub location is right rear exiting upward

Features

- Fits comfortably into new and existing interconnect, cross-connect, customer premise, and co-location environments
- Most common connector styles and types available
- Compatible with industry standard equipment frames
- LGX compatible master plate and footprint (118 mm)
- Modular design
- Provides maximum protection of optical components

Applications

- Telecommunications closets
- Data Centers
- Customer Premise
- LAN / WAN Networks
- Central Offices / Headends
- Hubs / Cabinets / Remote Terminals
- FTTH / FTTB Networks

Dimensions

DEPTH (A) IN INCHES	WIDTH (B) IN INCHES	HEIGHT (C) IN INCHES	RACK UNITS	FIBER CAPACITY	UNLOADED WEIGHT	MATERIAL GAUGE
11.00	17.00	7.00	4	72/96/144	9 lbs.	2.03 mm

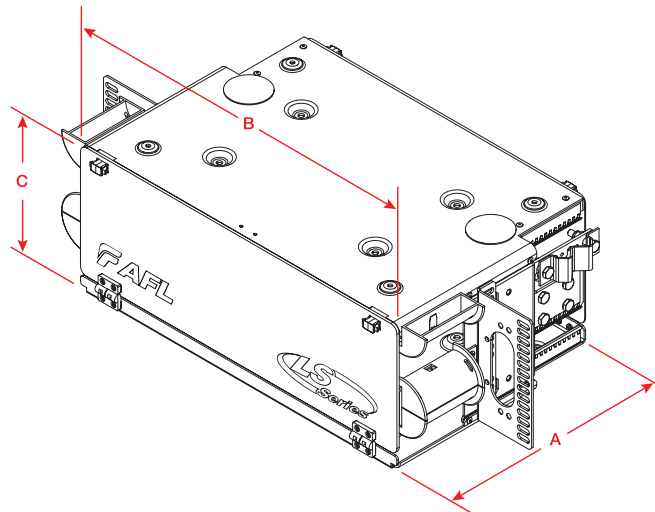

LGX is a registered trademark of Furukawa Electric North America, Inc.
Telcordia is a registered trademark of Telcordia Technologies, Inc.

LightLink LANSystem 4RU Fiber Termination Patch Panel

Ordering Information

Select the seven digit AFL panel part number, specify the color, and choose the loading character desired.

When ordering stubbed (S), enter the cable stub length required in meters.

Note: Standard stub is Circular Premise Cable (CPC).

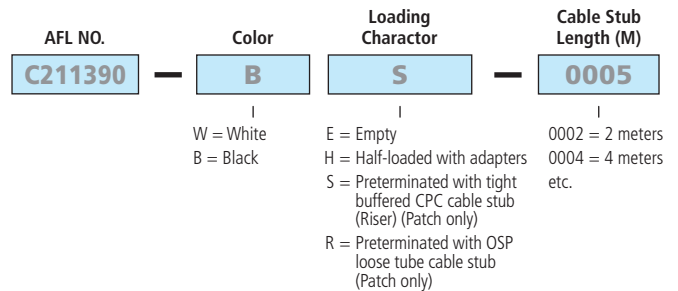

Example: Order number for a panel Black in color, loaded with 72 PSC adapters (12 six packs), connectors and a cable stub 5 meters in length.

Ordering Information

CONFIGURATION	AFL NO.
CON072P—4 RU PATCH PANELS—72 FIBERS—LGX118	
EMPTY	C211372
72 PSC adapters (12 Six Packs)	C211390
72 UST adapters (12 Six Packs)	C211417
72 PST adapters (12 Six Packs)	C211426
36 UDL (dup) adapters (12 Three Packs)	FM000191
36 PDL (dup) adapters (12 Three Packs)	FM000192
72 ASC adapters (12 Six Packs)	C213955
72 UFC adapters (12 Six Packs)	C213941
72 USC adapters (12 Six Packs)	C213952
72 AFC adapters (12 Six Packs)	C213946
36 PSF (dup) adapters (12 Three Packs)	FM000193
36 USF (dup) adapters (12 Three Packs)	FM000136
36 ASF (dup) adapters (12 Three Packs)	FM000194

CONFIGURATION	AFL NO.
CON096P—4 RU PATCH PANELS—96 FIBERS—LGX118	
EMPTY	FM000344
96 PSC adapters (12 Eight Packs)	FM000203
96 UST adapters (12 Eight Packs)	C213964
96 PST adapters (12 Eight Packs)	FM000204
96 ASC adapters (12 Eight Packs)	C213982
96 UFC adapters (12 Eight Packs)	C213970
96 USC adapters (12 Eight Packs)	C213977
96 AFC adapters (12 Eight Packs)	C213973

Notes:
 1) All MM cable is 62.5 µm unless otherwise specified.
 2) When ordering Empty Termination Patch/Splice Panel, accessories are available for field configuration.

Qualifications

GOVERNING BODY	STANDARD CODE
ASTM	ASTMB209
Telcordia	GR-63NEBS

CONFIGURATION	AFL NO.
CON144HD—4 RU HIGH DENSITY PATCH PANELS—144 FIBERS—LGX118	
EMPTY	FM000344
72 UDL (dup) adapters (12 Six Packs)	C211432
72 ADL (dup) adapters (12 Six Packs)	FM000345
72 PSF (dup) adapters (12 Six Packs)	C211396
72 PDL (dup) adapters (12 Six Packs)	C211439
72 USF (dup) adapters (12 Six Packs)	FM000196
72 ASF (dup) adapters (12 Six Packs)	FM000197
144 UST adapters (12 Twelve Packs)	FM000198
144 PST adapters (12 Twelve Packs)	FM000199
144 UFC adapters (12 Twelve Packs)	FM000200
144 USC adapters (12 Twelve Packs)	FM000133
144 ASC adapters (12 Twelve Packs)	FM000201

Connector/Adapter Key

TYPE	DESCRIPTION
ASC	SC—Angle Polish, Simplex, SM
ASF	SC—Angle Polish, Duplex, SM
PSC	SC—Physical Polish, Simplex, MM
PSF	SC—Physical Polish, Duplex, MM
USC	SC—Ultra Polish, Simplex, SM
USF	SC—Ultra Polish, Duplex, SM
PST	ST—Physical Polish, Simplex, MM
UST	ST—Ultra Polish, Simplex, SM
AFC	FC—Angle Polish, Simplex, SM
PFC	FC—Physical Polish, Simplex, MM
UFC	FC—Ultra Polish, Simplex, SM
ADL	LC—Angle Polish, Duplex, SM
PLC	LC—Physical Polish, Simplex, MM
PDL	LC—Physical Polish, Duplex, MM
ULC	LC—Ultra Polish, Simplex, SM
UDL	LC—Ultra Polish, Duplex, SM



LightLink LANSystem 5RU Fiber Termination Patch Panel

The AFL 5RU Fiber Termination Patch Panel is designed for use as a rack mount interconnect point where termination and connectivity of up to 288 fibers is desired. The panel design is based on a 5 rack unit height with a master plate that is provisioned with twelve LGX® 170 compatible mounting positions that can accommodate adapter plates, XFM® optical cassettes, passive optical modules or any combination therein.

Standard 5RU Fiber Termination Patch Panels are available empty for complete field configuration, half loaded with adapter plates, or stubbed with a factory installed circular premise cable (CPC) or loose tube cable assembly. High density panels utilize two 144 fiber stubs for 288 terminations.

Specifications

- Telcordia® GR-63 NEBS Tested
- Aluminum construction per ASTM B209
- Durable textured powder coat finish available in black or white
- Universal 19/23" EIA/TIA rack compatibility
- Standard density: up to 144-fiber
- High density: up to 288-fiber
- LGX 170 compatible
- Standard cable stub location is right rear exiting upward

Features

- Fits comfortably into new and existing interconnect, cross-connect, customer premise, and co-location environments
- Most common connector styles and types available
- Compatible with industry standard equipment frames
- LGX compatible master plate (170 mm)
- Modular design
- Provides maximum protection of optical components

Applications

- Telecommunications closets
- Data Centers
- Customer Premise
- LAN / WAN Networks
- Central Offices / Headends
- Hubs / Cabinets / Remote Terminals
- FTTH / FTTB Networks

Dimensions

DEPTH (A) IN INCHES	WIDTH (B) IN INCHES	HEIGHT (C) IN INCHES	RACK UNITS	FIBER CAPACITY	UNLOADED WEIGHT	MATERIAL GAUGE
11.00	17.00	8.75	5	144/288	9 lbs.	2.03 mm

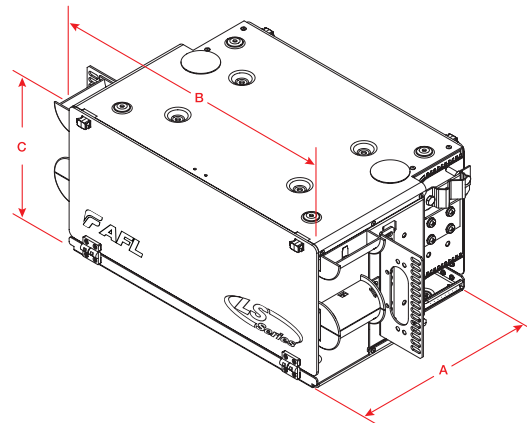

LGX is a registered trademark of Furukawa Electric North America, Inc.
Telcordia is a registered trademark of Telcordia Technologies, Inc.

LightLink LANSystem 5RU Fiber Termination Patch Panel

Ordering Information

Select the seven digit AFL panel part number, specify the color, and choose the loading character desired.

When ordering stubbed (S), enter the cable stub length required in meters.

Note: Standard stub is Circular Premise Cable (CPC).

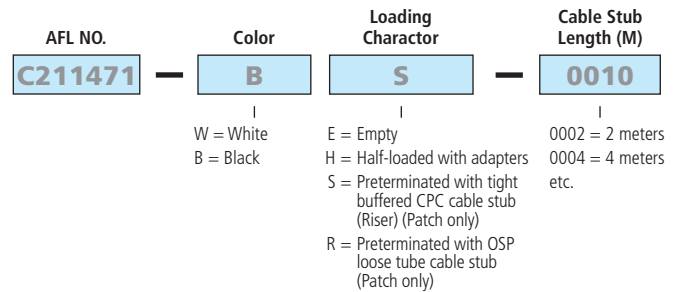

Example: Order number for a panel Black in color, loaded with 144 PSC adapters (12 twelve packs), connectors and a cable stub 10 meters in length.

Ordering Information

CONFIGURATION	AFL NO.
CON144P—5 RU PATCH PANELS—144 FIBERS—LGX170	
EMPTY	C211453
144 PSC adapters (12 Twelve Packs)	C211471
144 UST adapters (12 Twelve Packs)	C211498
144 PST adapters (12 Twelve Packs)	C211507
72 UDL (dup) adapters (12 Six Packs)	FM000206
72 PDL (dup) adapters (12 Six Packs)	FM000207
144 ASC adapters (12 Twelve Packs)	C214009
144 UFC adapters (12 Twelve Packs)	C213995
144 USC adapters (12 Twelve Packs)	C214006
72 PSF (dup) adapters (12 Six Packs)	FM000208
72 USF (dup) adapters (12 Six Packs)	FM000209
72 ASF (dup) adapters (12 Six Packs)	FM000210
CON288HD—5 RU HIGH DENSITY PATCH PANELS (USES TWO 144 STUBS)—LGX170	
144 UDL (dup) adapters (12 Twelve Packs)	C211511
144 ADL (dup) adapters (12 Twelve Packs)	FM000346
144 PSF (dup) adapters (12 Twelve Packs)	C211475
144 USF (dup) adapters (12 Twelve Packs)	FM000212
144 ASF (dup) adapters (12 Twelve Packs)	FM000213

Notes:

- 1) All MM cable is 62.5 μm unless otherwise specified.
- 2) When ordering Empty Termination Patch/Splice Panel, accessories are available for field configuration.

Qualifications

GOVERNING BODY	STANDARD CODE
ASTM	ASTMB209
Telcordia	GR-63NEBS

Connector/Adapter Key

TYPE	DESCRIPTION
ASC	SC—Angle Polish, Simplex, SM
ASF	SC—Angle Polish, Duplex, SM
PSC	SC—Physical Polish, Simplex, MM
PSF	SC—Physical Polish, Duplex, MM
USC	SC—Ultra Polish, Simplex, SM
USF	SC—Ultra Polish, Duplex, SM
PST	ST—Physical Polish, Simplex, MM
UST	ST—Ultra Polish, Simplex, SM
AFC	FC—Angle Polish, Simplex, SM
PFC	FC—Physical Polish, Simplex, MM
UFC	FC—Ultra Polish, Simplex, SM
ADL	LC—Angle Polish, Duplex, SM
PLC	LC—Physical Polish, Simplex, MM
PDL	LC—Physical Polish, Duplex, MM
ULC	LC—Ultra Polish, Simplex, SM
UDL	LC—Ultra Polish, Duplex, SM



LightLink LANSystem 6RU Fiber Patch and Splice Panel

The AFL 6RU Fiber Patch and Splice Panel is designed for use as a rack mount interconnect point where termination and connectivity of up to 96 fibers is desired. The two panel design is based on a 6-rack unit height comprised of a 3RU Termination Patch Panel and a 3RU Optical Splice Shelf. The 3RU Termination Patch Panel is provisioned with nine LGX® 118 compatible mounting positions. The 3RU Optical Splice Shelf utilizes two STF-48 telescoping splice drawers.

Standard 6RU Fiber Patch and Splice Panels are available empty for complete field configuration, half loaded with adapter plates and STF-48 telescoping splice trays, or loaded with pigtails, adapter plates and STF-48 telescoping splice trays.

Specifications

- Designed around Telcordia® GR-63NEBS
- Aluminum construction per ASTM B209
- Durable textured powder coat finish available in black or white
- Universal 19/23" EIA/TIA rack compatibility
- Standard density: up to 48-fiber
- High density: up to 96-fiber
- Fiber storage capacity—one meter per spliced fiber (3 mm jacket)
- Uses two STF-48 telescoping splice drawers
- Two panel package—3U patch, 3U splice
- Nine LGX 118 mm positions

Features

- Fits comfortably into new and existing interconnect, cross-connect, customer premise and co-location environments
- Most common connector styles and types available
- Compatible with industry standard equipment frames
- LGX-compatible master plate (118 mm)
- Modular design
- Compact and versatile method of organizing splicing and connectivity
- Provides maximum protection of optical components

Applications

- Telecommunications closets
- Data Centers
- Customer Premise
- LAN / WAN Networks
- Central Offices / Headends
- Hubs / Cabinets / Remote Terminals
- FTTH / FTTB Networks

Dimensions

DEPTH (A) IN INCHES	WIDTH (B) IN INCHES	HEIGHT (C) IN INCHES	RACK UNITS	FIBER CAPACITY
11.00	17.00	10.5	6	48/96

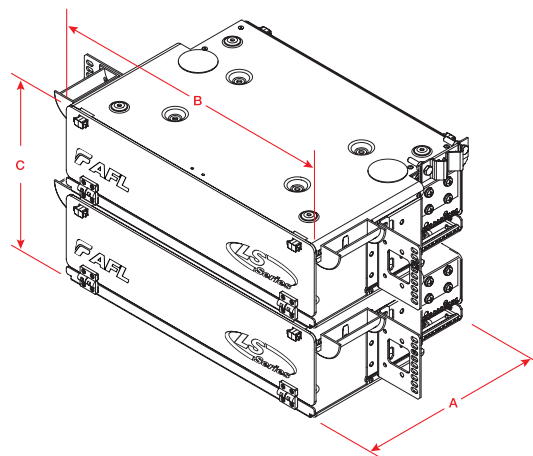

LGX is a registered trademark of Furukawa Electric North America, Inc.
Telcordia is a registered trademark of Telcordia Technologies, Inc.

LightLink LANSystem 6RU Fiber Patch and Splice Panel

Ordering Information

Select the seven-digit AFL panel part number, specify the color and choose the loading character desired.

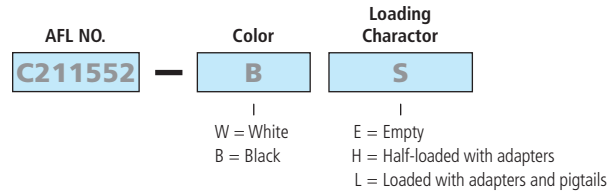

Example: Order number for a panel Black in color, loaded with, master plate, adapter plates, 48 PSC adapters (8 Six packs), splice drawer (2-48 position), pigtails with connectors, hardware, cable clamp.

Empty - Includes master plate, mounting hardware, cable clamp.

Unloaded - Includes master plate, adapter plates, adapters, splice drawer (48 & up), hardware, cable clamp.

Loaded - Includes master plate, adapter plates, adapters, splice drawer (48 & up), pigtails with connectors, hardware, cable clamp.

Configuration Part Numbers

CONFIGURATION	AFL NO.
CNS048P—6U PATCH & SPLICE PANELS (1 EA. 3U PATCH, 3U SPLICE)—LGX118	
EMPTY	C211534
48 PSC adapters (8 Six Packs) Splice Drawer (2-48 position)	C211552
48 UST adapters (8 Six Packs) Splice Drawer (2-48 position)	C211579
48 PST adapters (8 Six Packs) Splice Drawer (2-48 position)	C211588
24 UDL (dup) adapters (8 Three Packs) Splice Drawer (2-48 position)	FM000234
24 PDL (dup) adapters (8 Three Packs) Splice Drawer (2-48 position)	FM000235
48 ASC adapters (8 Six Packs) Splice Drawer (2-48 position)	C210928
48 UFC adapters (8 Six Packs) Splice Drawer (2-48 position)	C210913
48 USC adapters (8 Six Packs) Splice Drawer (2-48 position)	C210922
48 AFC adapters (8 Six Packs) Splice Drawer (2-48 position)	C210917
24 PSF (dup) adapters (8 Three Packs) Splice Drawer (2-48 position)	FM000236
24 USF (dup) adapters (8 Three Packs) Splice Drawer (2-48 position)	FM000237
24 ASF (dup) adapters (8 Three Packs) Splice Drawer (2-48 position)	FM000238
CNS096HD—6U HIGH DENSITY PATCH & SPLICE PANELS—LGX118	
96 UST adapters (8 Twelve Packs) Splice Drawer 2-48 position)	FM000240
96 PST adapters (8 Twelve Packs) Splice Drawer (2-48 position)	FM000241
48 UDL (dup) adapters (8 Six Packs) Splice Drawer (2-48 position)	C211594
48 PSF (dup) adapters (8 Six Packs) Splice Drawer (2-48 position)	C211558
48 PDL (dup) adapters (8 Six Packs) Splice Drawer (2-48 position)	C211601
48 USF (dup) adapters (8 Six Packs) Splice Drawer (2-48 position)	FM000242
48 ASF (dup) adapters (8 Six Packs) Splice Drawer (2-48 position)	FM000243

Notes:

- 1) All MM cable is 62.5 μm unless otherwise specified.
- 2) When ordering Empty Termination Patch/Splice Panel, accessories are available for field configuration.

Qualifications

GOVERNING BODY	STANDARD CODE
ASTM	ASTMB209
Telcordia	GR-63NEBS

Accessories

DESCRIPTION	AFL NO.
STF-48 Telescoping Splice Drawer	911442-00-00

Connector/Adapter Key

TYPE	DESCRIPTION
ASC	SC—Angle Polish, Simplex, SM
ASF	SC—Angle Polish, Duplex, SM
PSC	SC—Physical Polish, Simplex, MM
PSF	SC—Physical Polish, Duplex, MM
USC	SC—Ultra Polish, Simplex, SM
USF	SC—Ultra Polish, Duplex, SM
PST	ST—Physical Polish, Simplex, MM
UST	ST—Ultra Polish, Simplex, SM
AFC	FC—Angle Polish, Simplex, SM
PFC	FC—Physical Polish, Simplex, MM
UFC	FC—Ultra Polish, Simplex, SM
ADL	LC—Angle Polish, Duplex, SM
PLC	LC—Physical Polish, Simplex, MM
PDL	LC—Physical Polish, Duplex, MM
ULC	LC—Ultra Polish, Simplex, SM
UDL	LC—Ultra Polish, Duplex, SM

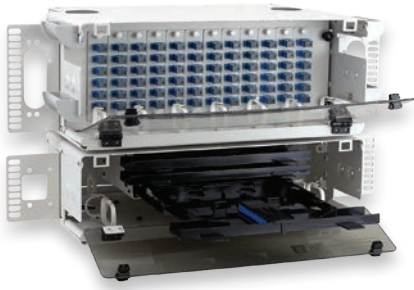

LightLink LANSys™ 7RU Fiber Patch and Splice Panel

The AFL 7RU Fiber Patch and Splice Panel is designed for use as a rack mount interconnect point where termination and connectivity of up to 144 fibers is desired. The two panel design is based on a 7 rack unit height comprised of a 4RU Termination Patch Panel and a 3RU Optical Splice Shelf. The 4RU Termination Patch Panel includes a master plate that is provisioned with 12 LGX® 118 compatible mounting positions. The 3RU Optical Splice Shelf utilizes three STF-48 telescoping splice drawers.

Standard 7RU Fiber Patch and Splice Panels are available empty for complete field configuration, half loaded with adapter plates and STF-48 telescoping splice trays, or loaded with pigtails, adapter plates and STF-48 telescoping splice trays.

Specifications

- Designed around Telcordia® GR-63NEBS
- Aluminum construction per ASTM B209
- Durable textured powder coat finish available in black or white
- Universal 19/23" EIA/TIA rack compatibility
- Standard density: up to 72-fiber
- High density: up to 144-fiber
- Fiber storage capacity—one meter per spliced fiber (3 mm jacket)
- Uses three STF-48 telescoping splice drawers
- Two panel package—4U patch and 3U splice
- 12 LGX 118 mm positions

Features

- Fits comfortably into new and existing interconnect, cross-connect, customer premise, and co-location environments
- Most common connector styles and types available
- Compatible with industry standard equipment frames
- LGX-compatible master plate (118 mm)
- Modular design
- Compact and versatile method of organizing splicing and connectivity
- Provides maximum protection of optical components

Applications

- Telecommunications closets
- Data Centers
- Customer Premise
- LAN / WAN Networks
- Central Offices / Headends
- Hubs / Cabinets / Remote Terminals
- FTTH / FTTB Networks

Dimensions

DEPTH (A) IN INCHES	WIDTH (B) IN INCHES	HEIGHT (C) IN INCHES	RACK UNITS	FIBER CAPACITY
11.00	17.00	12.25	7	72/144

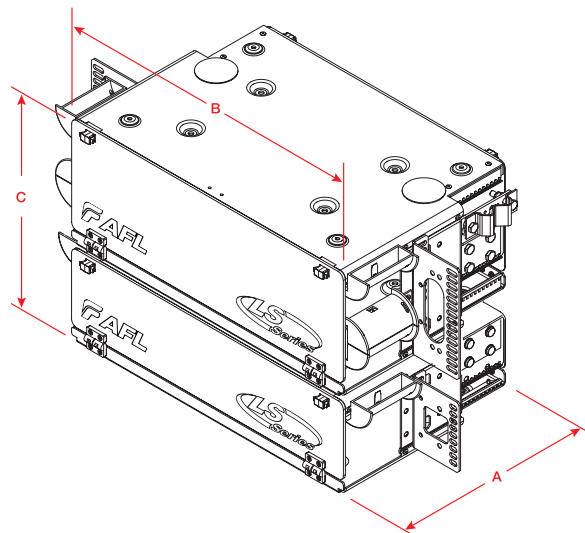

LGX is a registered trademark of Furukawa Electric North America, Inc.
Telcordia is a registered trademark of Telcordia Technologies, Inc.

LightLink LANsystem 7RU Fiber Patch and Splice Panel

Ordering Information

Select the seven-digit AFL number, specify the color and choose the loading character desired.

Example: Order number for a panel Black in color, loaded with master plate, adapter plates, 72 PSC adapters (12 Six packs), splice drawer (3-48 position), pigtails with connectors, hardware, cable clamp.

Ordering Information

CONFIGURATION	AFL NO.
CNS072P—7U PATCH & SPLICE PANELS (1 EA. 4U PATCH, 3U SPLICE)—LGX118	
EMPTY	C211615
72 PSC adapters (12 Six Packs)Splice Drawers (3-48 position)	C211633
72 UST adapters (12 Six Packs) Splice Drawers (3-48 position)	C211660
72 PST adapters (12 Six Packs)Splice Drawers (3-48 position)	C211669
36 UDL (dup) adapters (12 Three Packs)Splice Drawers (3-48 position)	FM000244
36 PDL (dup) adapters (12 Three Packs)Splice Drawers (3-48 position)	FM000245
72 ASC adapters (12 Six Packs)Splice Drawers (3-48 position)	C210958
72 UFC adapters (12 Six Packs)Splice Drawers (3-48 position)	C210946
72 USC adapters (12 Six Packs)Splice Drawers (3-48 position)	C210953
72 AFC adapters (12 Six Packs) Splice Drawers (3-48 position)	C210949
36 PSF (dup) adapters (12 Three Packs)Splice Drawers (3-48 position)	FM000246
36 USF (dup) adapters (12 Three Packs)Splice Drawers (3-48 position)	FM000247
36 ASF (dup) adapters (12 Three Packs)Splice Drawers (3-48 position)	FM000248
CNS096P—7U PATCH & SPLICE PANELS (1 EA. 4U PATCH, 3U SPLICE)—LGX118	
EMPTY	C210967
96 UST adapters (12 Eight Packs) Splice Drawers (2-48 position)	C210971
96 UFC adapters (12 Eight Packs) Splice Drawers (2-48 position)	C210976
96 AFC adapters (12 Eight Packs) Splice Drawers (2-48 position)	C210982
96 USC adapters (12 Eight Packs) Splice Drawers (2-48 position)	C210985
96 ASC adapters (12 Eight Packs) Splice Drawers (2-48 position)	C210989

Notes:

1) All MM cable is 62.5 µm unless otherwise specified.

2) When ordering Empty Termination Patch/Splice Panel, accessories are available for field configuration.

Qualifications

GOVERNING BODY	STANDARD CODE
ASTM	ASTMB209
Telcordia	GR-63NEBS

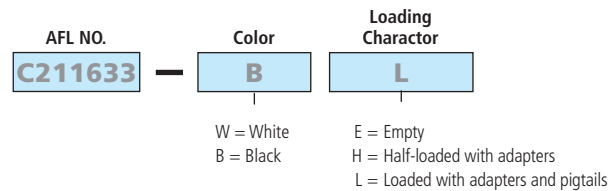

Empty - Includes master plate, mounting hardware, cable clamp.

Unloaded - Includes master plate, adapter plates, adapters, splice drawer (48 & up), hardware, cable clamp.

Loaded - Includes master plate, adapter plates, adapters, splice drawer (48 & up), pigtails with connectors, hardware, cable clamp.

CONFIGURATION	AFL NO.
CNS144HD—7RU HIGH DENSITY PATCH PANELS (1 EA. 4U PATCH, 3U SPLICE)—LGX118	
72 UDL (dup) adapters (12 Six Packs)Splice Drawers (3-48 position)	C211673
72 PSF (dup) adapters (12 Six Packs)Splice Drawers (3-48 position)	C211637
72 PDL (dup) adapters (12 Six Packs)Splice Drawers (3-48 position)	C211684
72 USF (dup) adapters (12 Six Packs)Splice Drawers (3-48 position)	FM000250
72 ASF (dup) adapters (12 Six Packs)Splice Drawers (3-48 position)	FM000251
144 UST adapters (12 Twelve Packs)Splice Drawers (3-48 position)	FM000252
144 PST adapters (12 Twelve Packs)Splice Drawers (3-48 position)	FM000253
144 UFC adapters (12 Twelve Packs)Splice Drawers (3-48 position)	FM000254
144 USC adapters (12 Twelve Packs)Splice Drawers (3-48 position)	FM000255
144 ASC adapters (12 Twelve Packs)Splice Drawers (3-48 position)	FM000256

Accessories

DESCRIPTION	AFL NO.
STF-48 Telescoping Splice Drawer	911442-00-00

Connector/Adapter Key

TYPE	DESCRIPTION
ASC	SC—Angle Polish, Simplex, SM
ASF	SC—Angle Polish, Duplex, SM
PSC	SC—Physical Polish, Simplex, MM
PSF	SC—Physical Polish, Duplex, MM
USC	SC—Ultra Polish, Simplex, SM
USF	SC—Ultra Polish, Duplex, SM
PST	ST—Physical Polish, Simplex, MM
UST	ST—Ultra Polish, Simplex, SM
AFC	FC—Angle Polish, Simplex, SM
PFC	FC—Physical Polish, Simplex, MM
UFC	FC—Ultra Polish, Simplex, SM
ADL	LC—Angle Polish, Duplex, SM
PLC	LC—Physical Polish, Simplex, MM
PDL	LC—Physical Polish, Duplex, MM
ULC	LC—Ultra Polish, Simplex, SM
UDL	LC—Ultra Polish, Duplex, SM

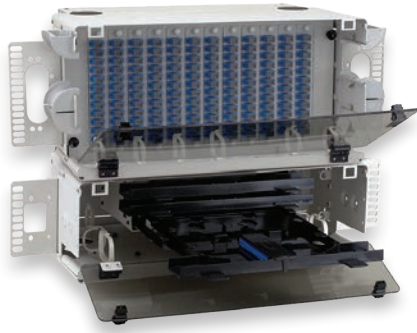

LightLink LANSystem 8RU Fiber Patch and Splice Panel

The AFL 8RU Fiber Patch and Splice Panel is designed for use as a rack mount interconnect point where termination and connectivity of up to 144 fibers is desired. The standard density, two panel design is based on an 8 rack unit height comprised of a 5RU Termination Patch Panel and a 3RU Optical Splice Shelf. The 5RU Termination Patch Panel includes a master plate that is provisioned with twelve LGX® 170 compatible mounting positions. The 3RU Optical Splice Shelf utilizes three STF-48 telescoping splice drawers.

Standard 8RU Fiber Patch and Splice Panels are available empty for complete field configuration, half loaded with adapter plates and STF-48 telescoping splice trays, or loaded with pigtails, adapter plates and STF-48 telescoping splice trays.

Specifications

- Designed around Telcordia® GR-63NEBS
- Aluminum construction per ASTM B209
- Durable textured powder coat finish available in black or white
- Universal 19/23" EIA/TIA rack compatibility
- Standard density: up to 144-fiber
- Fiber storage capacity—one meter per spliced fiber (3 mm jacket)
- Uses three STF-48 telescoping splice drawers
- Two panel package Standard Density: 5U patch and 3U splice
- 12 LGX 170 mm positions

Features

- Fits comfortably into new and existing interconnect, cross-connect, customer premise, and co-location environments
- Most common connector styles and types available
- Compatible with industry standard equipment frames
- LGX compatible master plate (170 mm)
- Modular design
- Compact and versatile method of organizing splicing and connectivity
- Provides maximum protection of optical components

Applications

- Telecommunications closets
- Data Centers
- Customer Premise
- LAN / WAN Networks
- Central Offices / Headends
- Hubs / Cabinets / Remote Terminals
- FTTH / FTTB Networks

Dimensions

PANEL VERSION	DEPTH (A) IN INCHES	WIDTH (B) IN INCHES	HEIGHT (C) IN INCHES	RACK UNITS	FIBER CAPACITY
Standard	11.00	17.00	14.00	8	144

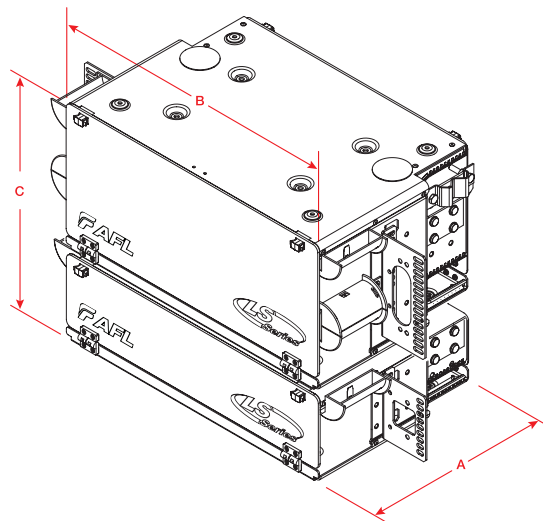

LGX is a registered trademark of Furukawa Electric North America, Inc.
Telcordia is a registered trademark of Telcordia Technologies, Inc.

LightLink LANSystem 8RU Fiber Patch and Splice Panel

Ordering Information

Select the seven-digit AFL number, specify the color and choose the loading character desired.

AFL NO.	Color	Loading Character
C211714	B	L
	W = White B = Black	E=Empty H = Half-loaded with adapters L=Loaded with adapters and pigtails

Example: Order number for a panel Black in color, loaded with, master plate, adapter plates, 144 PSC adapters (12 Twelve packs), splice drawer (3-48 position), pigtails with connectors, hardware, cable clamp.

Empty - Includes master plate, mounting hardware, cable clamp.

Unloaded - Includes master plate, adapter plates, adapters, splice drawer (48 & up), hardware, cable clamp.

Loaded - Includes master plate, adapter plates, adapters, splice drawer (48 & up), pigtails with connectors, hardware, cable clamp.

Configuration Part Numbers

CONFIGURATION	AFL NO.
CNS144P—8U PATCH & SPLICE PANELS (1 EA. 4U PATCH, 3U SPLICE)—LGX170	
EMPTY	C211696
144 PSC adapters (12 Twelve Packs) Splice Drawers (3-48 position)	C211714
144 UST adapters (12 Twelve Packs) Splice Drawers (3-48 position)	C211741
144 PST adapters (12 Twelve Packs) Splice Drawers (3-48 position)	C211750
72 UDL (dup) adapters (12 Six Packs) Splice Drawers (3-48 position)	FM000258
72 PDL (dup) adapters (12 Six Packs) Splice Drawers (3-48 position)	FM000259
144 ASC adapters (12 Twelve Packs) Splice Drawers (3-48 position)	C211021
144 UFC adapters (12 Twelve Packs) Splice Drawers (3-48 position)	C211007
144 USC adapters (12 Twelve Packs) Splice Drawers (3-48 position)	FM000260
72 PSF (dup) adapters (12 Six Packs) Splice Drawers (3-48 position)	FM000261
72 USF (dup) adapters (12 Six Packs) Splice Drawers (3-48 position)	FM000262
72 ASF (dup) adapters (12 Six Packs) Splice Drawers (3-48 position)	FM000263

Notes:

- 1) All MM cable is 62.5 µm unless otherwise specified.
- 2) When ordering Empty Termination Patch/Splice Panel, accessories are available for field configuration.

Qualifications

GOVERNING BODY	STANDARD CODE
ASTM	ASTMB209
Telcordia	GR-63NEBS

Accessories

DESCRIPTION	AFL NO.
STF-48 Telescoping Splice Drawer	911442-00-00

Connector/Adapter Key

TYPE	DESCRIPTION
ASC	SC—Angle Polish, Simplex, SM
ASF	SC—Angle Polish, Duplex, SM
PSC	SC—Physical Polish, Simplex, MM
PSF	SC—Physical Polish, Duplex, MM
USC	SC—Ultra Polish, Simplex, SM
USF	SC—Ultra Polish, Duplex, SM
PST	ST—Physical Polish, Simplex, MM
UST	ST—Ultra Polish, Simplex, SM
AFC	FC—Angle Polish, Simplex, SM
PFC	FC—Physical Polish, Simplex, MM
UFC	FC—Ultra Polish, Simplex, SM
ADL	LC—Angle Polish, Duplex, SM
PLC	LC—Physical Polish, Simplex, MM
PDL	LC—Physical Polish, Duplex, MM
ULC	LC—Ultra Polish, Simplex, SM
UDL	LC—Ultra Polish, Duplex, SM

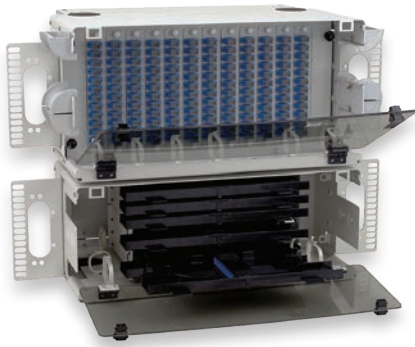

LightLink LANSystem 10RU Fiber Patch and Splice Panel

The AFL 10RU Fiber Patch and Splice Panel is designed for use as a rack mount interconnect point where termination and connectivity of up to 288 fibers is desired. The standard density, two panel design is based on a 10 rack unit height comprised of a 5RU Termination Patch Panel and a 5RU Optical Splice Shelf. The 5RU Termination Patch Panel includes a master plate that is provisioned with 12 LGX® 170 compatible mounting positions. The 5RU Optical Splice Shelf utilizes six STF-48 telescoping splice drawers.

Standard 10RU Fiber Patch and Splice Panels are available empty for complete field configuration, half loaded with adapter plates and STF-48 telescoping splice trays, or loaded with pigtails, adapter plates and STF-48 telescoping splice trays.

Specifications

- Designed around Telcordia® GR-63NEBS
- Aluminum construction per ASTMB209
- Durable textured powder coat finish available in black or white
- Universal 19/23" EIA/TIA rack compatibility
- Standard density: up to 288 fiber
- Fiber storage capacity—one meter per spliced fiber (3 mm jacket)
- Uses six STF-48 telescoping splice drawers
- Two panel package Standard Density: 5U patch and 5U splice
- 12 LGX 170 mm positions

Features

- Fits comfortably into new and existing interconnect, cross-connect, customer premise, and co-location environments
- Most common connector styles and types available
- Compatible with industry standard equipment frames
- LGX compatible master plate (170 mm)
- Modular design
- Compact and versatile method of organizing splicing and connectivity
- Provides maximum protection of optical components

Applications

- Telecommunications closets
- Data Centers
- Customer Premise
- LAN / WAN Networks
- Central Offices / Headends
- Hubs / Cabinets / Remote Terminals
- FTTH / FTTB Networks

Dimensions

PANEL VERSION	DEPTH (A) IN INCHES	WIDTH (B) IN INCHES	HEIGHT (C) IN INCHES	RACK UNITS	FIBER CAPACITY
Standard	11.00	17.00	17.5	10	288

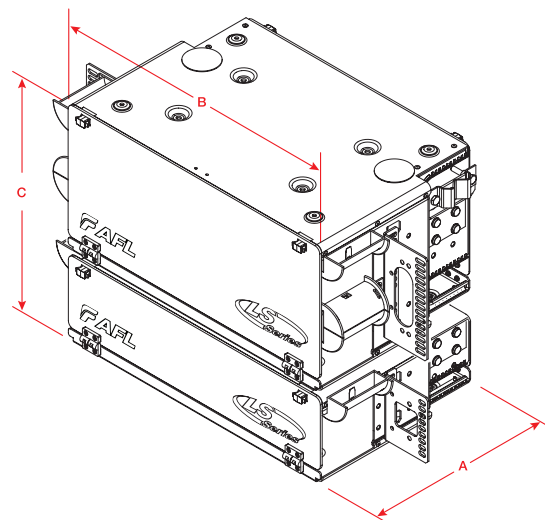

LGX is a registered trademark of Furukawa Electric North America, Inc.
Telcordia is a registered trademark of Telcordia Technologies, Inc.

LightLink LANSystem 10RU Fiber Patch and Splice Panel

Ordering Information

Select the seven-digit AFL number, specify the color and choose the loading character desired.

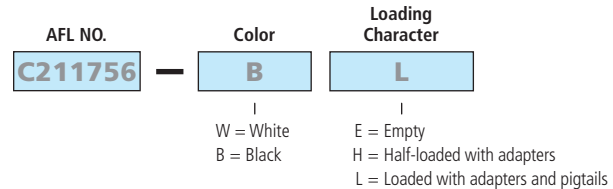

Example: Order number for a panel Black in color, loaded with master plate, adapter plates, 144 UDL adapters (12 Twelve packs), splice drawer (6-48 position), pigtails with connectors, hardware, cable clamp.

Empty - Includes master plate, mounting hardware, cable clamp.

Unloaded - Includes master plate, adapter plates, adapters, splice drawer (48 & up), hardware, cable clamp.

Loaded - Includes master plate, adapter plates, adapters, splice drawer (48 & up), pigtails with connectors, hardware, cable clamp.

Configuration Part Numbers

CONFIGURATION	AFL NO.
CNS288P—10U PATCH & SPLICE PANELS (1 EA. 5U PATCH, 5U SPLICE)—LGX170	
144 UDL (dup) adapters (12 Twelve Packs) Splice Drawers (6-48 position)	C211756
144 PDL (dup) adapters (12 Twelve Packs) Splice Drawers (6-48 position)	C211763
144 USF (dup) adapters (12 Twelve Packs) Splice Drawers (6-48 position)	FM000265
144 ASF (dup) adapters (12 Twelve Packs) Splice Drawers (6-48 position)	FM000266

Notes:

- 1) All MM cable is 62.5 μm unless otherwise specified.
- 2) When ordering Empty Termination Patch/Splice Panel, accessories are available for field configuration.

Accessories

DESCRIPTION	AFL NO.
STF-48 Telescoping Splice Drawer	911442-00-00

Connector/Adapter Key

TYPE	DESCRIPTION
ASC	SC—Angle Polish, Simplex, SM
ASF	SC—Angle Polish, Duplex, SM
PSC	SC—Physical Polish, Simplex, MM
PSF	SC—Physical Polish, Duplex, MM
USC	SC—Ultra Polish, Simplex, SM
USF	SC—Ultra Polish, Duplex, SM
PST	ST—Physical Polish, Simplex, MM
UST	ST—Ultra Polish, Simplex, SM
AFC	FC—Angle Polish, Simplex, SM
PFC	FC—Physical Polish, Simplex, MM
UFC	FC—Ultra Polish, Simplex, SM
ADL	LC—Angle Polish, Duplex, SM
PLC	LC—Physical Polish, Simplex, MM
PDL	LC—Physical Polish, Duplex, MM
ULC	LC—Ultra Polish, Simplex, SM
UDL	LC—Ultra Polish, Duplex, SM

Qualifications

GOVERNING BODY	STANDARD CODE
ASTM	ASTMB209
Telcordia	GR-63NEBS
EIA/TIA	EIA/TIA 455-A

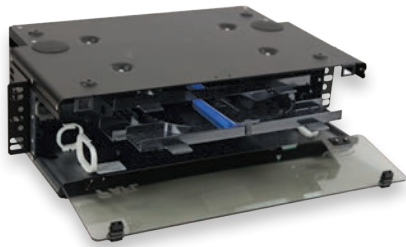

SPL3RU

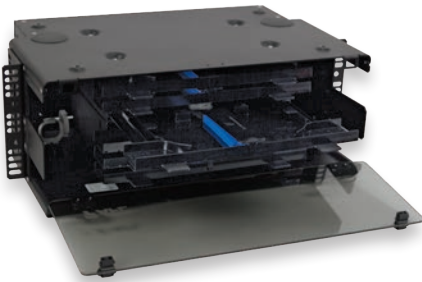

SPL5RU

LightLink LANSystem SPL3RU and SPL5RU—Optical Splice Shelf

The LightLink LANSystem Optical Splice Shelf is designed to provide a convenient in-rack splicing and interconnection point for Outside Plant (OSP) cable entering a Central Office (CO), Controlled Environmental Vault (CEV), Headend (HE) or customer location. Units are available with three or six STF-48 Telescoping Splice Drawers. Each drawer is capable of handling up to 48 individual single-fused or up to 144 mass-fused fibers, with minimum bend radius routing and protection.

Features

- Fits comfortably into new and existing interconnect, cross-connect, customer premise, and co-location environments
- Compatible with industry standard equipment frames
- For in-rack splicing of outside plant cable to connectorized pigtails or riser cable
- Drawers handle up to 48 single-fused or 144 mass-fused fibers
- Cable entry/exit grommet seals
- Durable and scratch resistant power coated antique white finish
- Hinged plexiglass front and rear door
- Spring loaded latches

Applications

- Telecommunications closets
- Data Centers
- Customer Premise
- LAN / WAN Networks
- Central Offices / Headends
- Hubs / Cabinets / Remote Terminals
- FTTH / FTTB Networks

Specifications

- Designed around Telcordia® GR-63NEBS
- Aluminum construction per ASTM B209
- Durable textured powder coat finish available in black or white
- Universal 19/23" EIA/TIA rack compatibility

Dimensions

MODEL	NO. OF TRAYS	DEPTH (A) (inches)	WIDTH (B) (inches)	HEIGHT (C) (inches)	RACK UNITS	SPLICE CAPACITY	UNLOADED WEIGHT	MATERIAL GAUGE
SPL3RU	3	11.00	17.00	5.25	3	144 single, 432 mass	8.4 lbs.	2.03 mm
SPL5RU	6	11.00	17.00	8.75	5	288 single, 864 mass	9.0 lbs.	2.03 mm

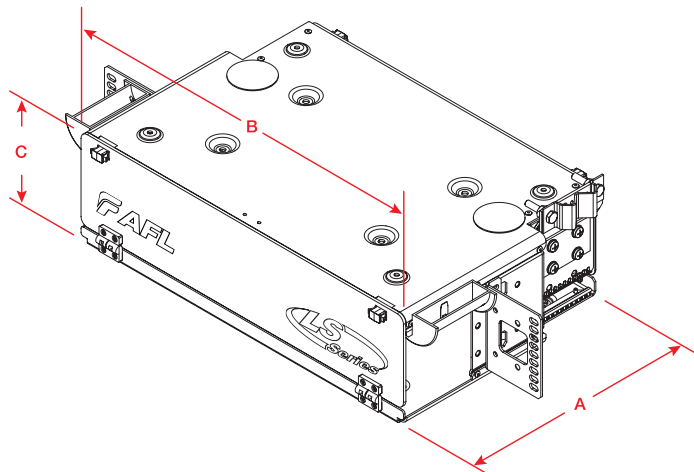

LGX is a registered trademark of Furukawa Electric North America, Inc.
Telcordia is a registered trademark of Telcordia Technologies, Inc.

LightLink LANSystem SPL3RU and SPL5RU—Optical Splice Shelf

Ordering Information

DESCRIPTION	AFL NO.
SPL3RU	
White, 3RU Optical Splice Shelf—EMPTY	C211777 - W
Black, 3RU Optical Splice Shelf—EMPTY	C211777 - B
White, 3RU Optical Splice Shelf—with 3 telescoping splice drawers	C211781 - W
Black, 3RU Optical Splice Shelf—with 3 telescoping splice drawers	C211781 - B
SPL5RU	
White, 5RU Optical Splice Shelf—EMPTY	C211795 - W
Black, 5RU Optical Splice Shelf—EMPTY	C211795 - B
White, 5RU Optical Splice Shelf—with 6 telescoping splice drawers	C211799 - W
Black, 5RU Optical Splice Shelf—with 6 telescoping splice drawers	C211799 - B

Accessories

DESCRIPTION	AFL NO.
STF-48 Telescoping Splice Drawer, up to 48 single fused or 144 mass fused splices	911442-00-00
1x8 Universal Core Tube Fiber Routing Kit	FC000008
1x6 Universal Ribbon or Loose Tube Fiber Routing Kit	FC000070

Qualifications

GOVERNING BODY	STANDARD CODE
ASTM	ASTMB209
Telcordia	GR-63NEBS

Xpress Fiber Management® (XFM®) 1RU Patch Panel

The Xpress Fiber Management (XFM) 1U patch panel is a rack mountable interconnect point specifically designed to manage dense fiber applications. Based on the LGX® intermateability platform, the panel is fully compatible with AFL's XFM Optical Cassette, Passive Optical Coupler Modules, and Poli-MOD® solutions. This panel offers enhanced management of densities up to 72 fibers using MTP-LC XFM Optical Cassettes (24 fibers).



Features

- Steel construction
- Textured black powder coat finish
- Universal WECO/TIA 19"/23" rack compatibility
- (3) LGX 118 adapter plate / module mounting positions
- Slide-out tray with relief cut-outs for simplified connector access
- Optional front door key lock for heightened protection of internal components

Applications

- Data Centers
- Enterprise Networks
- Telecommunications Closets
- Central Offices / Headends

Specifications

DEPTH (A) (inches)	WIDTH (B) (inches)	HEIGHT (C) (inches)	RACK UNITS	CAPACITY	UNLOADED WEIGHT
15.5	17	1.7	1	(3) LGX 118	13 lbs.

Ordering Information

DESCRIPTION	MODEL NUMBER	AFL NO.
Xpress Fiber Management 1U Patch Panel, Black, Empty	XFM-1-U-B-0	FM002711-BE

Accessories

DESCRIPTION	AFL NO.
Kit, Lock, for CON/CNS Panels	FM001318

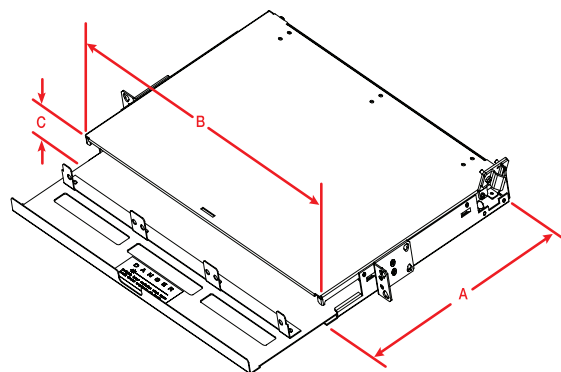

LGX is a registered trademark of Furukawa Electric North America, Inc.

Xpress Fiber Management® (XFM) 2RU Patch Panel

The Xpress Fiber Management (XFM) 2U patch panel is a rack mountable interconnect point specifically designed to manage dense fiber applications. Based on the LGX® intermateability platform, the panel is fully compatible with AFL's XFM Optical Cassette, Passive Optical Coupler Modules, and Poli-MOD® solutions. This panel offers enhanced management of densities up to 144 fibers using MTP-LC XFM Optical Cassettes (24 fibers).



Features

- Steel construction
- Textured black powder coat finish
- Universal WECO/TIA 19"/23" rack compatibility
- (6) LGX 118 adapter plate / module mounting positions
- Slide-out tray with relief cut-outs for simplified connector access
- Optional front door key lock for heightened protection of internal components

Applications

- Data Centers
- Enterprise Networks
- Telecommunications Closets
- Central Offices / Headends

Specifications

DEPTH (A) IN INCHES	WIDTH (B) IN INCHES	HEIGHT (C) IN INCHES	RACK UNITS	CAPACITY	UNLOADED WEIGHT
15.5	17	3.5	2	(6) LGX 118	15 lbs.

Ordering Information

DESCRIPTION	MODEL NUMBER	AFL NO.
Xpress Fiber Management 2U Patch Panel, Black, Empty	XFM-2-U-B-0	FM002712-BE

Accessories

DESCRIPTION	AFL NO.
Kit, Lock, for CON/CNS Panels	FM001318

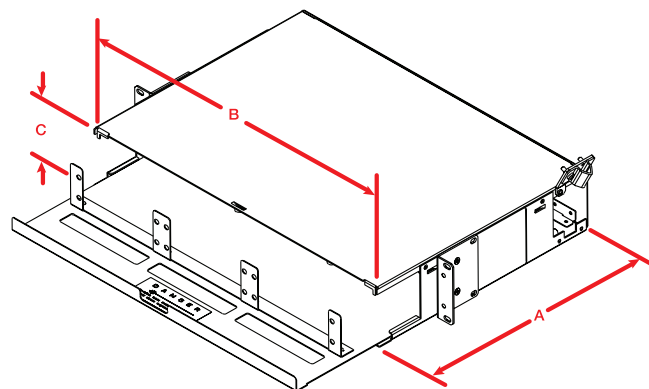

LGX is a registered trademark of Furukawa Electric North America, Inc.



Xpress Fiber Management® (XFM®) 4RU Patch Panel

The Xpress Fiber Management (XFM) 4RU patch panel is a rack mountable interconnect point specifically designed to manage dense fiber applications. Based on the LGX® intermateability platform, the panel is fully compatible with AFL's XFM Optical Cassette, Poli-MOD® and WDM solutions, offering enhanced management of densities up to 288F using MTP/MPO, single fiber, or patch and splice methodologies. Routing rings on the top and bottom of the front panel provide enhanced cable routing allowing cable assemblies to exit comfortably. This panel can be provisioned with a key lock at the time of order for secure environments.

Features

- Aluminum construction
- Textured black powder coat finish
- Universal WECO/TIA 19"/23" rack compatibility
- (12) LGX 118 adapter plate / module mounting positions
- Mounting depth adjustable from flush to 8" in 1" increments

Applications

- Data Centers
- Enterprise Networks
- Telecommunications Closets
- Central Offices / Headends

Specifications

DEPTH (A) IN INCHES	FRONT WIDTH (B) IN INCHES	REAR WIDTH (C) IN INCHES	HEIGHT (D) IN INCHES	RACK UNITS	CAPACITY	UNLOADED WEIGHT
15.5	17	15	7	4	(12) LGX 118	9 lbs.

Ordering Information

DESCRIPTION	MODEL NO.	AFL NO.
Xpress Fiber Management 4U Patch Panel, Black, Empty	XFM-4U-B-0	FM001090-B
Xpress Fiber Management 4U Patch Panel, Black, Empty, Key Lock	XFM-4U-B-K	FM001218-B

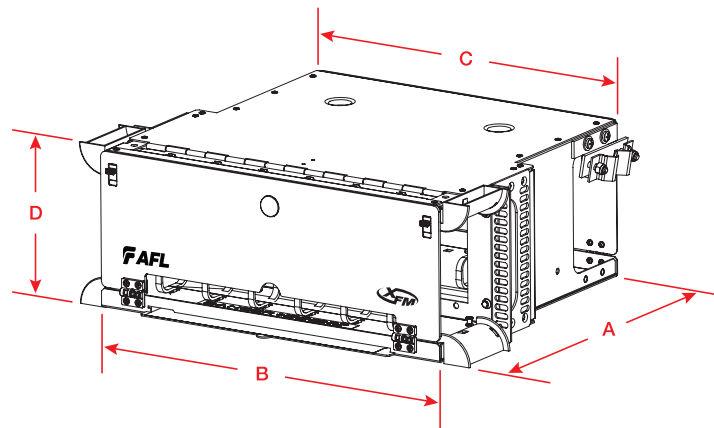

LGX is a registered trademark of Furukawa Electric North America, Inc.



Xpress Fiber Management® (XFM®) 5RU Shelf

The Xpress Fiber Management (XFM) 5RU Shelf is a rack-mountable interconnect panel specifically designed to manage fibers in Wavelength Division Multiplexing (WDM) applications or in situations where fiber entry will occur only at the front entrance of the panel. Based on the LGX® intermateability platform, the panel is fully compatible with AFL's WDM, XFM® Optical Cassette and Poli-MOD® solutions. Routing rings on the bottom of the front panel allow cable assemblies to exit comfortably, while the back of the panel is left open to reduce size and weight.

The XFM Shelf can be conveniently mounted at three depths within the rack which includes a flush-mount option. The XFM Shelf also features a clear, removable front door and a pull-out cable designator card.

Features

- Aluminum construction
- Textured black powder coat finish
- Universal WECO/TIA 19"/23" rack compatibility
- (12) LGX 118 module mounting positions

Applications

- Central Offices / Headends
- Data Centers
- Wavelength Division Multiplexing

Specifications

DEPTH (A) IN INCHES*	FRONT WIDTH (B) IN INCHES	REAR WIDTH (C) IN INCHES	HEIGHT (D) IN INCHES	RACK UNITS	CAPACITY	UNLOADED WEIGHT
7.5	17	17	8.75	5	(12) LGX 118	4 lbs.

*Does not include installed modules

Ordering Information

DESCRIPTION	AFL NO.
Xpress Fiber Management 5RU Patch Panel, Shelf, Black	FM003626

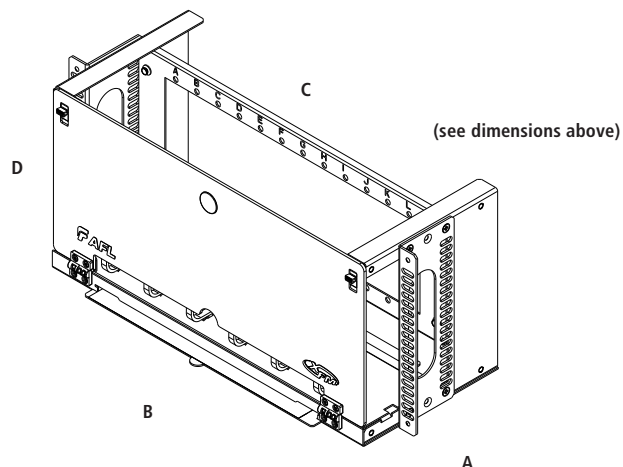



Front View—Door Open



Side Ports and Lower Pass-thru

XFM®-28 Dual Access Module Panel

AFL's XFM-28 Dual Access Module Panel is designed to maximize module capacity via both front and rear access in just four rack units.

In applications where additional rack space is unavailable, the XFM-28 doubles the capacity of traditional 14 slot, front-access only 4RU panels, offering a total of 28 slots to accommodate modules (14 front / 14 rear). The panel is lightweight yet robust, with efficient cable management features for routing flexibility.

Features

- Dual access via front and rear panel doors
- Aluminum construction
- Universal WECO/TIA 19"/23" rack compatibility
- (28) LGX® 118 module mounting positions (14 front / 14 rear)
- Cable management features include side cable ports and full pass-thru underneath the main bulkhead compartment to allow cable routing from front to back within the panel without eliminating any module positions

Specifications

DEPTH	WIDTH	HEIGHT	RACK UNITS	CAPACITY	UNLOADED WEIGHT
21 in.	17 in.	7 in.	4	(28) LGX 118	10 lbs.

Ordering Information

DESCRIPTION	MODEL NO.	AFL NO.
XFM-28, Enclosure, 4RU, 19/23"	XFM-28	FM004268

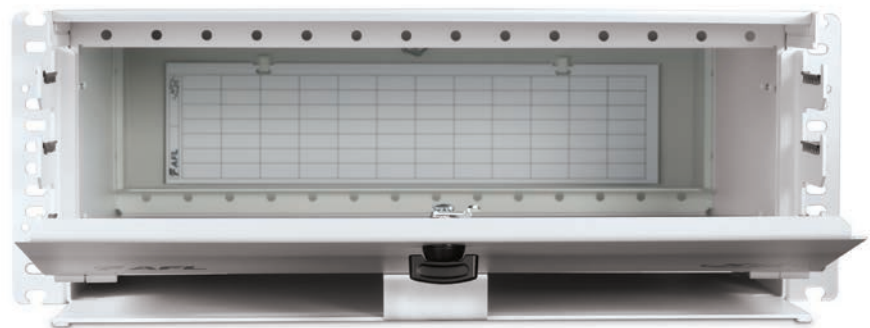

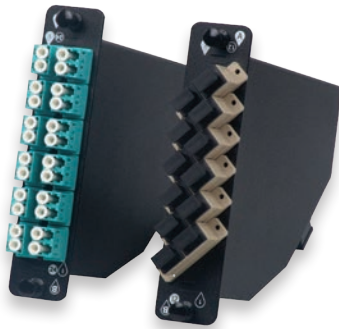

Xpress Fiber Management® (XFM) MPO Optical Cassettes

AFL's Xpress Fiber Management Optical Cassette product line is a family of preterminated fanout modules that streamline the deployment of optical network infrastructure. The primary function of these products is to break out multi-fiber ribbon connectors to simplex or duplex style connectors for connection to adjacent network elements.

The Xpress Fiber Management Optical Cassette solution features low-loss MPO style trunk cable assemblies. These cassettes are available in the industry standard LGX® footprint as well as a selection of Corning Cable Systems™ footprints to support embedded base installations. All modules feature a durable powder coat finish, and are compatible with all 1U-4U LANSysSystem platforms. All modules are clearly labeled with a silk-screened "A" and "B" positioning reference to ensure proper polarity is maintained in the network, referenced to the polarity convention being deployed. Method "F" is also available.

Applications

- Data centers
- LAN, WAN and SAN
- Interoffice cross-connects
- Campus environments

Features

- 12- and 24- port configurations
- Single-slot LGX packages
- Compatible with LANSysSystem and WME hardware
- Available in black with rear MPO connection(s)
- SMF, 62.5 μm MMF and 50 μm MMF supported
- SC- and LC-MPO standard configurations
- ST- and FC-MPO configurations available on special order

Optical Performance Data

PARAMETER	Single-mode Fiber (OS1)					Multimode Fiber (OM1, OM2 and 50 μm Laser Optimized)		
	LC - MPO	LCAPC - MPO	SC - MPO	SCAPC - MPO	ST - MPO	LC - MPO	SC - MPO	ST - MPO
Max IL (dB)	1.15	1.15	1.3	1.3	1.3	1.15	1.3	1.3
Typical IL (dB)	0.6	0.6	0.6	0.6	0.6	0.6	0.6	0.6
Reflectance (dB)	-55	-65	-55	-65	-55	-30	-30	-30

Notes:

1. Single-mode IL test wavelengths 1310 nm and 1550 nm
2. Multimode IL test wavelengths 850 nm and 1300 nm
3. Single-mode RL test wavelengths 1310 nm and 1550 nm
4. Multimode RL test wavelengths 850 nm and 1300 nm

Ordering Information (Method A/B)

FIBER COUNT, CONNECTOR OPTION	SINGLE-MODE		MULTIMODE	
	UPC - MPO (MALE, APC)	APC - MPO (Male, APC)	62.5 μm OM1 PC - MPO (Male, PC)	50 μm LOMMF OM4 PC - MPO (Male, PC)
12F, LC	FM000090-B	FM001477-B	FM000092-B	FM000273-B
24F, LC	FM000691-B	FM001653-B	FM000663-B	FM000692-B
12F, SC	FM000087-B	FM001465-B	FM000089-B	FM000272-B
12F, ST	FM000093-B	N/A	FM000095-B	FM000274-B

Ordering Information (Method F)

FIBER COUNT, CONNECTOR OPTION	SINGLE-MODE		MULTIMODE
	UPC - MPO (MALE, APC)	APC - MPO (Male, APC)	50 μm LOMMF OM4 PC - MPO (Male, PC)
12F, LC	FM004756-B	FM004757-B	FM004832-B
24F, LC	FM004653-B	FM004831-B	FM004613-B

LGX is a registered trademark of Furukawa Electric North America, Inc.

Telcordia is a registered trademark of Telcordia Technologies, Inc.

Xpress Fiber Management® (XFM) MPO Optical Cassettes

Ordering Information – Accessories

DESCRIPTION	AFL NO.
145 mm Adapter Bracket	FM001636

NOTE: Allows standard LGX modules, such as AFL's Poli-Mod Interconnect Module and the XFM Optical Cassette, to be mounted into existing Corning Cable Systems™ CCH series and PCH series racks and wall mount products.

Dimensions

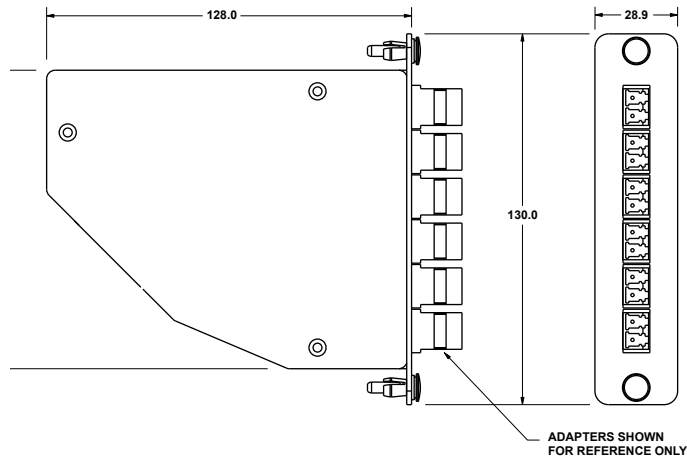

Qualifications

GOVERNING BODY	STANDARD CODE
ANSI/TIA/EIA	ANSI/TIA/EIA-568-B.3
Telcordia	GR-326
Telcordia	GR-1435



ASCEND Fiber Housings in Rack

Features

- High Density: 1RU/144F, 2RU/288F and 4RU/576F
- Designed for 19" rack. Optional 23" rack mount kit available.
- Galvannealed steel construction
- Hinged front and rear doors and removable back cover
- BASE-8, BASE-12, BASE-24 and WDM compatibility
- Interchangeable cassette options for multiple applications
- Cassettes install independently from front or rear of housing; WDM cassettes install from front only
- Trunk cable management area accommodates ASCEND Trunk Cable Assemblies equipped with integrated cable mounting clip
- Compatible with all ASCEND Cassettes

Applications

- Data Centers
- Central Offices
- Headends
- Structured Cabling Networks
- Wavelength Division Multiplexing (WDM)

ASCEND® Fiber Housings

ASCEND fiber housings are available in 1RU, 2RU and 4RU sizes with densities of up to 144, 288, and 576 fibers for LC connections, respectively. Designed to support incremental growth or a full-scale deployment, ASCEND housings provide the ultimate in ease-of-use and fiber management features.

ASCEND housings are 19" or 23" (separate kit) rack-mountable and constructed using galvannealed steel for an extended service life. The front and rear doors are both hinged on the bottom, while the rear section of the housing cover is removable on the 1RU and 2RU for unobstructed access to all connector interfaces. The 4RU Housing features a fixed top equipped with lance positions to accommodate additional trunk cable assemblies, enabling both bottom and top cable entry and flexible routing options. Integrated routing rings at the front of the trays enable secure and organized routing of patch cords which facilitates efficient Moves, Adds and Changes (MACs).

The rear of the housing incorporates a trunk cable management area which features multiple trunk cable outback clip mounting positions that are designed to securely manage slack while allowing the trays to slide in/out for installation and service.

NOTE: A separate external cable mounting bracket is required if non-ASCEND cable assemblies are going to be installed in ASCEND Fiber Housings.

Ordering Information

PANEL TYPE	DESCRIPTION	AFL NO.
BASE-8	ASCEND HOUSING, 1RU, BASE-8 TRAYS	ASCEND-1RU-8-RT
	ASCEND HOUSING, 2RU, BASE-8 TRAYS	ASCEND-2RU-8-RT
	ASCEND HOUSING, 4RU, BASE-8 TRAYS	ASCEND-4RU-8-RT
BASE-12	ASCEND HOUSING, 1RU, BASE-12 TRAYS	ASCEND-1RU-12-RT
	ASCEND HOUSING, 2RU, BASE-12 TRAYS	ASCEND-2RU-12-RT
	ASCEND HOUSING, 4RU, BASE-12 TRAYS	ASCEND-4RU-12-RT
BASE-24	ASCEND HOUSING, 1RU, BASE-24 TRAYS	ASCEND-1RU-24-RT
	ASCEND HOUSING, 2RU, BASE-24 TRAYS	ASCEND-2RU-24-RT
	ASCEND HOUSING, 4RU, BASE-24 TRAYS	ASCEND-4RU-24-RT

ASCEND® Fiber Housings



ASCEND 1RU

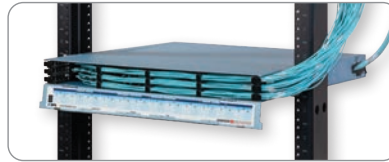

ASCEND 1RU front



ASCEND 2RU

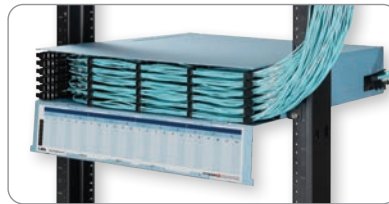

ASCEND 2RU front



ASCEND 4RU

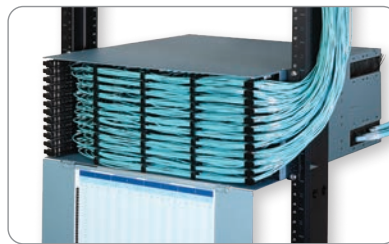

ASCEND 4RU front

Specifications

PARAMETER	MODEL		
	ASCEND 1RU	ASCEND 2RU	ASCEND 4RU
Rack Space	1 RU	2 RU	4 RU
Fiber Density (BASE-12, BASE-24)	144 (LC), 864 (MPO)	288 (LC), 1,728 (MPO)	576 (LC), 3,456 (MPO)
Fiber Density (BASE-8)	144 (LC), 576 (MPO)	288 (LC), 1,152 (MPO)	576 (LC), 2,304 (MPO)
Number of Trays	3	6	12
Cassette Capacity	18 x BASE-8 Cassettes (6 per tray) 12 x BASE-12 Cassettes (4 per tray) 6 x BASE-24 Cassettes (2 per tray)	36 x BASE-8 Cassettes (6 per tray) 24 x BASE-12 Cassettes (4 per tray) 12 x BASE-24 Cassettes (2 per tray)	72 x BASE-8 Cassettes (6 per tray) 48 x BASE-12 Cassettes (4 per tray) 24 x BASE-24 Cassettes (2 per tray)
WDM Module Capacity*	12 x WDM 1/4 Size Modules (4 per tray) 6 x WDM 1/2 Size Modules (2 per tray) 3 x WDM Full Size Modules (1 per tray)	24 x WDM 1/4 Size Modules (4 per tray) 12 x WDM 1/2 Size Modules (2 per tray) 6 x WDM Full Size Modules (1 per tray)	48 x WDM 1/4 Size Modules (4 per tray) 24 x WDM 1/2 Size Modules (2 per tray) 12 x WDM Full Size Modules (1 per tray)
Dimensions (HxWxD)	44.5 x 438.2 x 501.6 mm 1.75 x 17.25 x 19.75 in.	88.9 x 438.2 x 501.6 mm 3.5 x 17.25 x 19.75 in.	177.8 x 438.2 x 501.6 mm 7.0 x 17.25 x 19.75 in.
Weight	7.5 kg (16.6 lbs)	10.2 kg (22.4 lbs)	15.7 kg (34.6 lbs)
Color	Blue	Blue	Blue
Material	Metal Components: 16 GA Galvannealed Sheet Steel per ASTM A653	Metal Components: 16 GA Galvannealed Sheet Steel per ASTM A653	Metal Components: 16 GA Galvannealed Sheet Steel per ASTM A653

* WDM Module sizes may be combined in same tray. For example, 1/4 size module (QTY 2) and 1/2 size module (QTY 1).

Qualifications

GOVERNING BODY	STANDARD CODE
RoHS	Compliant



ASCEND® Optical Cassettes

ASCEND optical cassettes are the building blocks of the high density platform and are available in a wide range of configurations for multiple applications in BASE-8, BASE-12 and BASE-24 configurations.

Available in single-mode and multimode fiber types, ASCEND optical cassettes feature low loss MPO connectors and VFL-compatible shuttered LC adapters.

ASCEND cassettes are compatible with all ASCEND housings and can be independently installed from the front or rear of the housing onto a sliding tray system. This allows access to individual connections while minimizing disruption to other fiber connections.

Features

- Wide variety of cassettes for multiple applications
 - Fanout
 - Patch
 - Splice
 - WDM
- BASE-8, BASE-12 and BASE-24 configurations
- SM, MM (OM3) and MM (OM4)
- Low loss MPO connectors
- VFL-compatible shuttered LC adapters
- Install independently from front or rear of housing
- Compatible with all ASCEND housings

Applications

- Data Centers
- Central Offices
- Headends
- Structured Cabling Networks



ASCEND® Fanout Cassettes

ASCEND Fanout Cassettes are pre-terminated plug-and-play breakout modules designed to transition a trunk cable into individual connector ports. Available in single-mode and multimode fiber types, Fanout Cassettes feature low-loss MPO connectors and VFL-compatible shuttered LC adapters. All cassettes are offered in BASE-8, BASE-12 and BASE-24 configurations.

Fanout Cassettes are compatible with all standard ASCEND housings and can be independently installed from the front or rear onto a sliding tray system. This allows access to individual connections while minimizing disruption to other fiber connections.

Optical Performance Data

PARAMETER	Single-mode Fiber (OS2)	Single-mode Fiber (OS2)	Multimode Fiber (OM3/4)
	LC/UPC - MPO	LC/APC - MPO	LC/PC - MPO
Max IL (dB)	0.55	0.60	0.45
Typical IL (dB)	0.35	0.35	0.30
Reflectance (dB)	-55	-60	-20
Dimensions (L x W) (mm)	132.5 x 94	132.5 x 94	132.5 x 94
Color	Blue - Black	Green - Black	Aqua - Black

Features

- Plug and Play
- BASE-8, BASE-12 or BASE-24 configurations
- SM, MM (OM3) and MM (OM4)
- VFL-compatible shuttered Quad LC adapters
- Low loss MPO connectors
- Compatible with all ASCEND housings
- Install independently from front or rear of housing

Applications

- Data Centers
- Central Offices
- Headends
- Structured Cabling Networks

Ordering Information (BASE-8 and BASE-12)

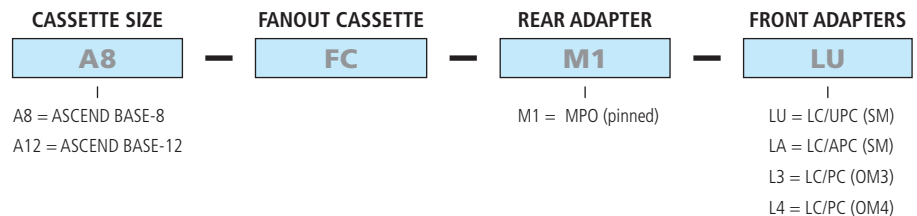

CATEGORY	DESCRIPTION	AFL NO.
BASE-8 FANOUT CASSETTES	ASCEND-8 FANOUT CASSETTE, BASE-8, PINNED MPO-LC/UPC, SM	A8-FC-M1-LU
	ASCEND-8 FANOUT CASSETTE, BASE-8, PINNED MPO-LC/APC, SM	A8-FC-M1-LA
	ASCEND-8 FANOUT CASSETTE, BASE-8, PINNED MPO-LC/PC, OM3	A8-FC-M1-L3
	ASCEND-8 FANOUT CASSETTE, BASE-8, PINNED MPO-LC/PC, OM4	A8-FC-M1-L4
BASE-12 FANOUT CASSETTES	ASCEND-12 FANOUT CASSETTE, BASE-12, PINNED MPO-LC/UPC, SM	A12-FC-M1-LU
	ASCEND-12 FANOUT CASSETTE, BASE-12, PINNED MPO-LC/APC, SM	A12-FC-M1-LA
	ASCEND-12 FANOUT CASSETTE, BASE-12, PINNED MPO-LC/PC, OM3	A12-FC-M1-L3
	ASCEND-12 FANOUT CASSETTE, BASE-12, PINNED MPO-LC/PC, OM4	A12-FC-M1-L4

ASCEND® Fanout Cassettes

Ordering Information (BASE-24)

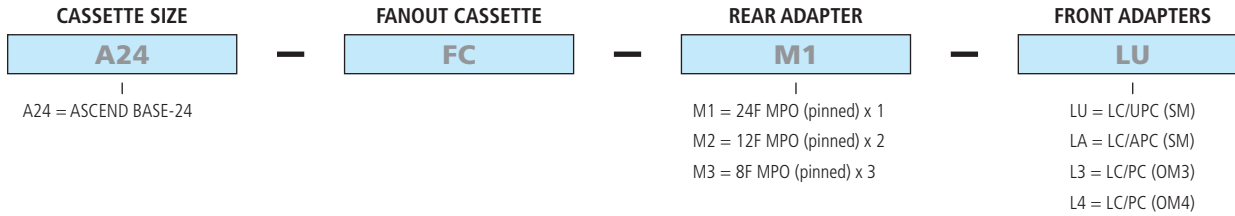

CATEGORY	DESCRIPTION	AFL NO.
BASE-24 FANOUT CASSETTES	ASCEND-24 FANOUT CASSETTE, BASE-24, PINNED 24F MPO-LC/UPC, SM	A24-FC-M1-LU
	ASCEND-24 FANOUT CASSETTE, BASE-24, PINNED 24F MPO-LC/APC, SM	A24-FC-M1-LA
	ASCEND-24 FANOUT CASSETTE, BASE-24, PINNED 24F MPO-LC/PC, OM3	A24-FC-M1-L3
	ASCEND-24 FANOUT CASSETTE, BASE-24, PINNED 24F MPO-LC/PC, OM4	A24-FC-M1-L4
	ASCEND-24 FANOUT CASSETTE, BASE-24, PINNED 12F MPO-LC/UPC, SM	A24-FC-M2-LU
	ASCEND-24 FANOUT CASSETTE, BASE-24, PINNED 12F MPO-LC/APC, SM	A24-FC-M2-LA
	ASCEND-24 FANOUT CASSETTE, BASE-24, PINNED 12F MPO-LC/PC, OM3	A24-FC-M2-L3
	ASCEND-24 FANOUT CASSETTE, BASE-24, PINNED 12F MPO-LC/PC, OM4	A24-FC-M2-L4
	ASCEND-24 FANOUT CASSETTE, BASE-24, PINNED 8F MPO-LC/UPC, SM	A24-FC-M3-LU
	ASCEND-24 FANOUT CASSETTE, BASE-24, PINNED 8F MPO-LC/APC, SM	A24-FC-M3-LA
	ASCEND-24 FANOUT CASSETTE, BASE-24, PINNED 8F MPO-LC/PC, OM3	A24-FC-M3-L3
	ASCEND-24 FANOUT CASSETTE, BASE-24, PINNED 8F MPO-LC/PC, OM4	A24-FC-M3-L4

Qualifications

GOVERNING BODY	STANDARD CODE
RoHS	Compliant



ASCEND® Mesh Cassettes

ASCEND Mesh Cassettes offer a way to switch ports without using LC connectivity. These cassettes are offered with four 8-fiber MPO adapters in the rear of the cassette and four 8-fiber MPO adapters in the front of the cassette with an internal fanout assembly that breaks out the rear 40G ports to each front MPO connector. This solution allows for a higher fiber density per RU.

Features

- Higher Density Connectivity, 32 fibers per cassette compared to 12 fibers using LC
- Compatible with all Base-12 ASCEND Housings
- Plug and Play
- Low Loss MPO connectors
- Quick installation

Applications

- Data Centers
- Central Offices
- Headends
- Structured Cabling Networks

Optical Performance Data

OPERATING WAVELENGTHS	INSERTION LOSS *	REFLECTANCE
SM: 1310 and 1550 nm MM: 850 and 1300 nm	Typical IL (dB): 0.35 dB Max IL (dB): 0.55 dB	SM: 50 dB MM: 20 dB

* For grade B MPOs, the mean IL is ≤ 0.12 dB and max IL ≤ 0.25 dB for 97% of samples. Elite MTPs maintain max IL ≤ 0.25 dB for 98% of samples. The probability of both two mated pairs in a module being less than 0.25 dB each is 96%.

Temperature Specifications

Operating Temperature	-20°C to +75°C
Storage Temperature	-40°C to +85°C

Ordering Information

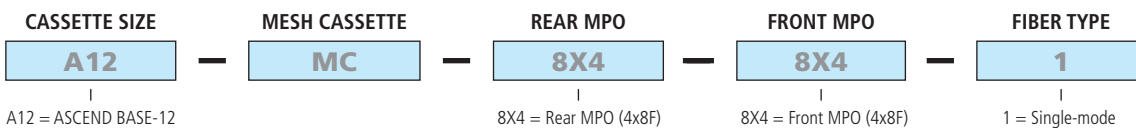

DESCRIPTION	AFL NO.
ASCEND-12 Mesh Cassette, Base-12, 8X4 MPO Rear, 8X4 MPO Front, Single-mode	A12-MC-8X4-8X4-1



ASCEND® Patch Cassettes

ASCEND Patch Cassettes are pre-loaded with MPO adapters or VFL-compatible shuttered LC adapters. Available in BASE-8 and BASE-12 configurations, Patch Cassettes install easily from the front or rear of any standard ASCEND housing. Each cassette independently mounts onto a sliding tray which allows access to individual connections while minimizing disruption to other fiber connections.

Features

- Plug and Play
- Install independently from front or rear of housing
- Compatible with all ASCEND housings
- Standard Duplex MPO or VFL-compatible shuttered Quad LC adapters

Applications

- Data Centers
- Central Offices
- Headends
- Structured Cabling Networks

Ordering Information

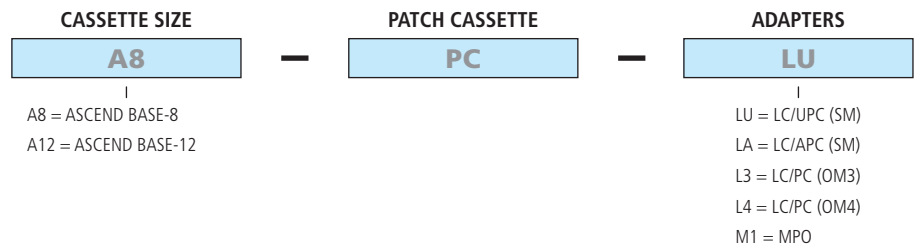

CATEGORY	DESCRIPTION	ADAPTERS/ FIBER COUNT	AFL NO.
BASE-8 PATCH CASSETTES	ASCEND-8 PATCH CASSETTE, BASE-8, LC/UPC, SM	8 LC/UPC (8 Fibers)	A8-PC-LU
	ASCEND-8 PATCH CASSETTE, BASE-8, LC/APC, SM	8 LC/APC (8 Fibers)	A8-PC-LA
	ASCEND-8 PATCH CASSETTE, BASE-8, LC/PC, OM3	8 LC/PC (8 Fibers)	A8-PC-L3
	ASCEND-8 PATCH CASSETTE, BASE-8, LC/PC, OM4	8 LC/PC (8 Fibers)	A8-PC-L4
	ASCEND-8 PATCH CASSETTE, BASE-8, MPO	4 MPO (48 Fibers)	A8-PC-M1
BASE-12 PATCH CASSETTES	ASCEND-12 PATCH CASSETTE, BASE-12, LC/UPC, SM	12 LC/UPC (12 Fibers)	A12-PC-LU
	ASCEND-12 PATCH CASSETTE, BASE-12, LC/APC, SM	12 LC/APC (12 Fibers)	A12-PC-LA
	ASCEND-12 PATCH CASSETTE, BASE-12, LC/PC, OM3	12 LC/PC (12 Fibers)	A12-PC-L3
	ASCEND-12 PATCH CASSETTE, BASE-12, LC/PC, OM4	12 LC/PC (12 Fibers)	A12-PC-L4
	ASCEND-12 PATCH CASSETTE, BASE-12-MPO (4 MPO Only)	4 MPO (48 Fibers)	A12-PC-M4
	ASCEND-12 PATCH CASSETTE, BASE-12, MPO	6 MPO (72 Fibers)	A12-PC-M1

Qualifications

GOVERNING BODY	STANDARD CODE
RoHS	Compliant



ASCEND® Splice Cassettes

ASCEND Splice Cassettes include 250 micron pre-terminated single fiber pigtails, or one SpiderWeb Ribbon® (SWR®) pigtail, that are loaded within the cassette and can be spliced directly to loose (or ribbon) fiber cable.

All Splice Cassettes feature VFL-compatible shuttered LC adapters with up to 12-fiber capacity. Available in single-mode and multimode fiber types, cassettes leverage a snap-in splice sleeve cradle to securely manage both single and ribbon fiber arrangements. A clear, removable cover allows for easy fiber viewing and access.

Splice Cassettes are compatible with all BASE-12 ASCEND housings and can be independently installed easily from the front or rear onto a sliding tray system. This allows access to individual connections while minimizing disruption to other fiber connections.

Applications

- Data Centers
- Central Offices
- Headends
- Structured Cabling Networks

Features

- Up to 12-fiber interconnection capacity
- SM, MM (OM3) and MM (OM4)
- 250 µm color-coded single fibers or SWR options
- VFL-compatible shuttered Quad LC adapters
- Clear, removable cover for viewing and access
- Inventive splice sleeve cradle
- Organized fiber routing
- BASE-12 configurations only
- Install independently from front or rear of housing

Ordering Information

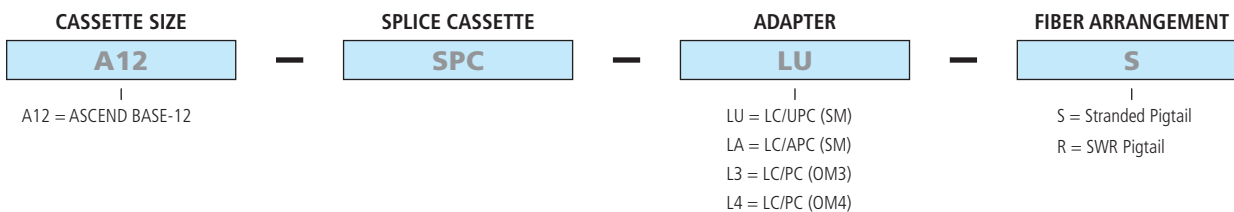

STRANDED FIBER		
CATEGORY	DESCRIPTION	AFL NO.
Single-mode	ASCEND-12 SPLICE CASSETTE, LC/UPC, SM, STRANDED PIGTAIL	A12-SPC-LU-S
	ASCEND-12 SPLICE CASSETTE, LC/APC, SM, STRANDED PIGTAIL	A12-SPC-LA-S
Multi-Mode	ASCEND-12 SPLICE CASSETTE, LC/PC, OM3, STRANDED PIGTAIL	A12-SPC-L3-S
	ASCEND-12 SPLICE CASSETTE, LC/PC, OM4, STRANDED PIGTAIL	A12-SPC-L4-S

SPIDERWEB RIBBON FIBER		
CATEGORY	DESCRIPTION	AFL NO.
Single-mode	ASCEND-12 SPLICE CASSETTE, LC/UPC, SM, SWR PIGTAIL	A12-SPC-LU-R
	ASCEND-12 SPLICE CASSETTE, LC/APC, SM, SWR PIGTAIL	A12-SPC-LA-R
Multi-Mode	ASCEND-12 SPLICE CASSETTE, LC/PC, OM3, SWR PIGTAIL	A12-SPC-L3-R
	ASCEND-12 SPLICE CASSETTE, LC/PC, OM4, SWR PIGTAIL	A12-SPC-L4-R

Qualifications

GOVERNING BODY	STANDARD CODE
RoHS	Compliant



BASE-24 to BASE-8 Cassette
AFL No. A8-CC-24X1-8X3-1-1



BASE-12 to BASE-8 Cassette (Single Circuit)
AFL No. A12-CC-24X1-8X3-1-1



BASE-12 to BASE-8 Cassette (Dual Circuit)
AFL No. A12-CC-12X2-8X3-2-1

ASCEND® Conversion Cassettes

AFL's Conversion Cassettes provide an effective solution to transition from one BASE platform to another.

The cassettes fully utilize each fiber in a BASE-12 or BASE-24 array by breaking out the MTP/ MPO adapters at the rear of the cassette into a corresponding number of BASE-8 adapters at the front.

Features

- Accommodates 12 or 24 fiber MTP/MPO connections at the rear of the cassette and effectively transitions to 8 fiber MTP/MPO connections at the front of the cassette
- Compatible with all ASCEND Housings and installed easily from the front or rear of a corresponding BASE-8 or BASE-12 tray

Applications

- Data Centers
- Central Offices
- Headends
- Structured Cabling Networks

Specifications

OPERATING WAVELENGTHS	INSERTION LOSS *	REFLECTANCE
SM: 1310 and 1550 nm MM: 850 and 1300 nm	Typical IL (dB): 0.35 dB Max IL (dB): 0.55 dB	SM: 50 dB MM: 20 dB

* For grade B MPOs, the mean IL is ≤ 0.12 dB and max IL ≤ 0.25 dB for 97% of samples. Elite MTPs maintain max IL ≤ 0.25 dB for 98% of samples. The probability of both two mated pairs in a module being less than 0.25 dB each is 96%.

Temperature Specifications

Operating Temperature	-20°C to +75°C
Storage Temperature	-40°C to +85°C

ASCEND® Conversion Cassettes

Schematics

BASE-24 to BASE-8

- A8-CC-24X1-8X3-1-1
- A8-CC-24X1-8X3-1-3
- A8-CC-24X1-8X3-1-4

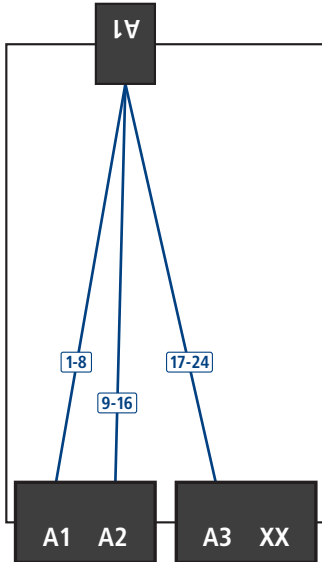

BASE-12 to BASE-8 (Single Circuit)

- A12-CC-12X2-8X3-1-1
- A12-CC-12X2-8X3-1-3
- A12-CC-12X2-8X3-1-4

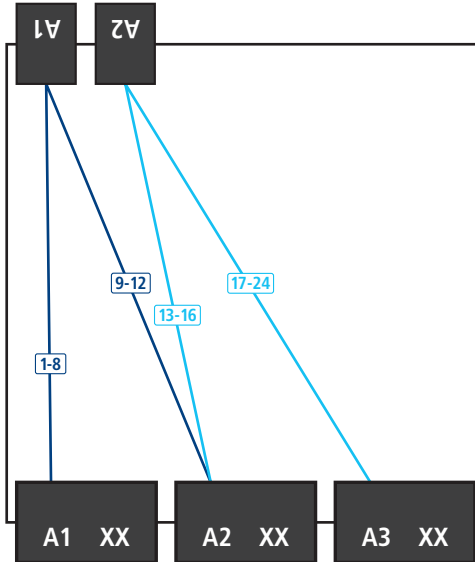

BASE-12 to BASE-8 (Dual Circuit)

- A12-CC-12X2-8X3-2-1
- A12-CC-12X2-8X3-2-3
- A12-CC-12X2-8X3-2-4

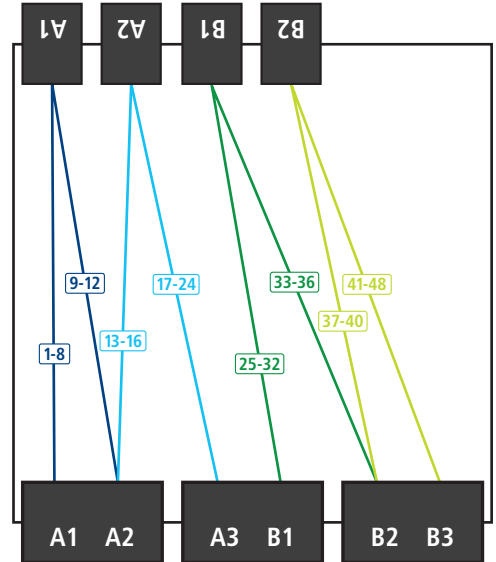

Ordering Information

BASE-24 TO BASE-8 CONVERSION CASSETTE OPTIONS		
CATEGORY	DESCRIPTION	AFL NO.
BASE 8	ASCEND-8 CONVERSION CASSETTE,BASE-8,24X1 MPO REAR,8X3 MPO FRONT,1 CIRCUIT,SM	A8-CC-24X1-8X3-1-1
	ASCEND-8 CONVERSION CASSETTE,BASE-8,24x1 MPO REAR,8X3 MPO FRONT,1 CIRCUIT,OM3	A8-CC-24X1-8X3-1-3
	ASCEND-8 CONVERSION CASSETTE,BASE-8,24X1 MPO REAR,8X3 MPO FRONT,1 CIRCUIT,OM4	A8-CC-24X1-8X3-1-4

BASE-12 TO BASE-8 CONVERSION CASSETTE OPTIONS		
CATEGORY	DESCRIPTION	AFL NO.
BASE 12	ASCEND-8 CONVERSION CASSETTE,BASE-8,24X1 MPO REAR,8X3 MPO FRONT,1 CIRCUIT,SM	A8-CC-24X1-8X3-1-1
	ASCEND-8 CONVERSION CASSETTE,BASE-8,24x1 MPO REAR,8X3 MPO FRONT,1 CIRCUIT,OM3	A8-CC-24X1-8X3-1-3
	ASCEND-8 CONVERSION CASSETTE,BASE-8,24X1 MPO REAR,8X3 MPO FRONT,1 CIRCUIT,OM4	A8-CC-24X1-8X3-1-4
	ASCEND-8 CONVERSION CASSETTE,BASE-8,24X1 MPO REAR,8X3 MPO FRONT,1 CIRCUIT,SM	A8-CC-24X1-8X3-1-1
	ASCEND-8 CONVERSION CASSETTE,BASE-8,24x1 MPO REAR,8X3 MPO FRONT,1 CIRCUIT,OM3	A8-CC-24X1-8X3-1-3
	ASCEND-8 CONVERSION CASSETTE,BASE-8,24X1 MPO REAR,8X3 MPO FRONT,1 CIRCUIT,OM4	A8-CC-24X1-8X3-1-4

Qualifications

GOVERNING BODY	STANDARD CODE	COMPONENT
EIA/TIA	568	Connectors
ITU-T	G.652.D and G.657-A1	Single Mode Fiber
IEC	60793-2-10 Type A1	OM1, OM2, OM3, OM4 Multimode Fiber
Telcordia	GR-20	Fiber
	GR-1435	Connectors
RoHS	Compliant Directive 2001/65/EU	Fiber and Connectors



BASE-8 Tap Cassette—Front and Rear Access
MPO Rear Input LC Input/ Output/Tap



BASE-12 Tap Cassette—Total Front Access
LC Input/ Output/Tap



BASE-12 Tap Cassette—Front and Rear Access
MPO Rear Input/ Output Front LC Tap ports

ASCEND® Tap Cassettes

High demands placed on modern fiber optic networks requires effective monitoring to maintain optimal performance and troubleshoot system security or other signal issues.

AFL's Tap Cassettes enable access points for monitoring live traffic signals in any fiber optic network.

Available with a variety of options to accommodate different split ratios for tap/ pass thru and input/ output configurations, it is quick and easy to tap and route network signals for any application.

Features

- Elite MPO connectors and adapters
- LC Shuttered Adapters
- Available with 50/50 and 30/70 Split Ratios to accommodate various Tap/ Pass Thru requirements
- Installs into all ASCEND Housings from the front or rear
- ITU-T G.657.D and G.652.A1 Compatible (SM)

Applications

- Data Centers
- Central Offices
- Headends
- Structured Cabling Networks

Temperature Specifications

Operating Temperature	-20°C to +75°C
Storage Temperature	-40°C to +85°C

ASCEND® Tap Cassettes

Specifications: Single-mode (SM)

OPTICAL WAVELENGTHS	POLARIZATION DEPENDENT LOSS (PDL)	CASSETTE TYPE	MAX INSERTION LOSS (IL) THRU PORT (dB) INCLUDING CONNECTORS	MAX INSERTION LOSS (IL) TAP PORT (dB) INCLUDING CONNECTORS	MIN RETURN LOSS (RL) (dB)
1310 nm +/- 40 nm	≤ 0.3 dB	50% Tap Port	4.1	4.1	50
1550 nm +/- 40 nm		30% Tap Port	2.6	6.5	50

Specifications: Multimode (MM)

OPTICAL WAVELENGTHS	CASSETTE TYPE	MAX INSERTION LOSS (IL) THRU PORT (dB) INCLUDING CONNECTORS	MAX INSERTION LOSS (IL) TAP PORT (dB) INCLUDING CONNECTORS	MIN RETURN LOSS (RL) (dB)
850 nm +/- 20 nm	50% Tap Port	4.1	4.1	20
1300 nm +/- 20 nm	30% Tap Port	2.6	6.5	20



ASCEND® Tap Cassettes

Schematics

BASE-8

- A8-TC-1-1-XXX-50-1
- A8-TC-1-1-XXX-30-1
- A8-TC-4-1-XXX-50-1
- A8-TC-4-1-XXX-30-1

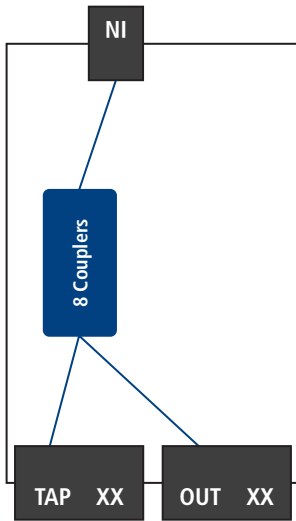

BASE-8

- A8-TC-1-2-ULC-50-1
- A8-TC-1-2-ULC-30-1
- A8-TC-1-2-ALC-50-1
- A8-TC-1-2-ALC-30-1
- A8-TC-4-2-PLC-50-1
- A8-TC-4-2-PLC-30-1

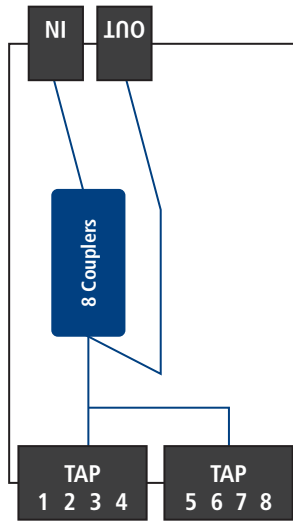

BASE-8

- A8-TC-1-3-ULC-50-1
- A8-TC-1-3-ULC-30-1
- A8-TC-1-3-ALC-50-1
- A8-TC-1-3-ALC-30-1
- A8-TC-4-3-PLC-50-1
- A8-TC-4-3-PLC-30-1

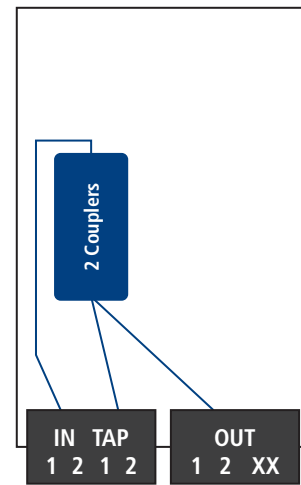

BASE-12

- A12-TC-1-1-XXX-50-1
- A12-TC-1-1-XXX-30-1
- A12-TC-4-1-XXX-50-1
- A12-TC-4-1-XXX-30-1

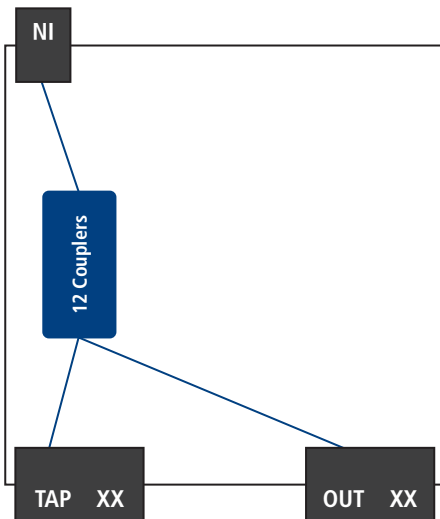

BASE-12

- A12-TC-1-2-ULC-50-1
- A12-TC-1-2-ULC-30-1
- A12-TC-1-2-ALC-50-1
- A12-TC-1-2-ALC-30-1
- A12-TC-4-2-PLC-50-1
- A12-TC-4-2-PLC-30-1

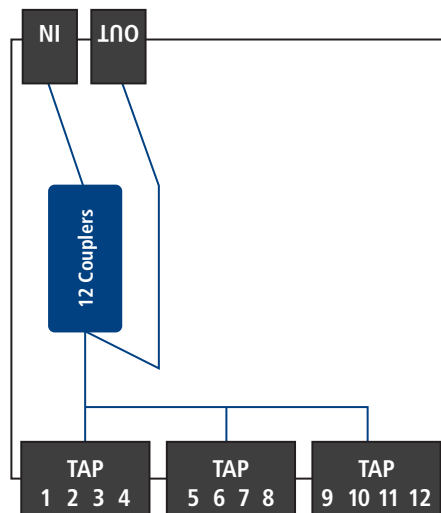

BASE-12

- A12-TC-1-3-ULC-50-1
- A12-TC-1-3-ULC-30-1
- A12-TC-1-3-ALC-50-1
- A12-TC-1-3-ALC-30-1
- A12-TC-4-3-PLC-50-1
- A12-TC-4-3-PLC-30-1

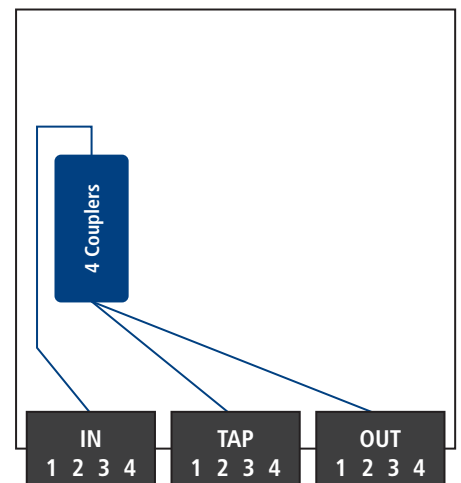

ASCEND® Tap Cassettes

Ordering Information

50/50 (TAP/ PASS THRU) SPLIT RATIO CONFIGURATIONS		
CATEGORY	DESCRIPTION	AFL NO.
BASE-8	ASCEND TAP CASSETTE, BASE-8, SM, MTP FRONT, MTP REAR, 50% TAP SPLIT, SINGLE	A8-TC-1-1-XXX-50-1
	ASCEND TAP CASSETTE, BASE-8, SM, LC/UPC FRONT, MTP REAR, 50% TAP SPLIT, SINGLE	A8-TC-1-2-U LC-50-1
	ASCEND TAP CASSETTE, BASE-8, SM, LC/APC FRONT, MTP REAR, 50% TAP SPLIT, SINGLE	A8-TC-1-2-ALC-50-1
	ASCEND TAP CASSETTE, BASE-8, SM, LC/UPC FRONT, 50% TAP SPLIT, SINGLE	A8-TC-1-3-U LC-50-1
	ASCEND TAP CASSETTE, BASE-8, SM, LC/APC FRONT, 50% TAP SPLIT, SINGLE	A8-TC-1-3-ALC-50-1
	ASCEND TAP CASSETTE, BASE-8, MM, MTP FRONT, MTP REAR, 50% TAP SPLIT, SINGLE	A8-TC-4-1-XXX-50-1
	ASCEND TAP CASSETTE, BASE-8, MM, LC/PC FRONT, MTP REAR, 50% TAP SPLIT, SINGLE	A8-TC-4-2-PLC-50-1
	ASCEND TAP CASSETTE, BASE-8, MM, LC/PC FRONT, 50% TAP SPLIT, SINGLE	A8-TC-4-3-PLC-50-1
BASE-12	ASCEND TAP CASSETTE, BASE-12, SM, MTP FRONT, MTP REAR, 50% TAP SPLIT, SINGLE	A12-TC-1-1-XXX-50-1
	ASCEND TAP CASSETTE, BASE-12, SM, LC/UPC FRONT, MTP REAR, 50% TAP SPLIT, SINGLE	A12-TC-1-2-U LC-50-1
	ASCEND TAP CASSETTE, BASE-12, SM, LC/APC FRONT, MTP REAR, 50% TAP SPLIT, SINGLE	A12-TC-1-2-ALC-50-1
	ASCEND TAP CASSETTE, BASE-12, SM, LC/UPC FRONT, 50% TAP SPLIT, SINGLE	A12-TC-1-3-U LC-50-1
	ASCEND TAP CASSETTE, BASE-12, SM, LC/APC FRONT, 50% TAP SPLIT, SINGLE	A12-TC-1-3-ALC-50-1
	ASCEND TAP CASSETTE, BASE-12, MM, MTP FRONT, MTP REAR, 50% TAP SPLIT, SINGLE	A12-TC-4-1-XXX-50-1
	ASCEND TAP CASSETTE, BASE-12, MM, LC/PC FRONT, MTP REAR, 50% TAP SPLIT, SINGLE	A12-TC-4-2-PLC-50-1
	ASCEND TAP CASSETTE, BASE-12, MM, LC/PC FRONT, 50% TAP SPLIT, SINGLE	A12-TC-4-3-PLC-50-1

30/70 (TAP/ PASS THRU) SPLIT RATIO CONFIGURATIONS		
CATEGORY	DESCRIPTION	AFL NO.
BASE-8	ASCEND TAP CASSETTE, BASE-8, SM, MTP FRONT, MTP REAR, 30% TAP SPLIT, SINGLE	A8-TC-1-1-XXX-30-1
	ASCEND TAP CASSETTE, BASE-8, SM, LC/UPC FRONT, MTP REAR, 30% TAP SPLIT, SINGLE	A8-TC-1-2-U LC-30-1
	ASCEND TAP CASSETTE, BASE-8, SM, LC/APC FRONT, MTP REAR, 30% TAP SPLIT, SINGLE	A8-TC-1-2-ALC-30-1
	ASCEND TAP CASSETTE, BASE-8, SM, LC/UPC FRONT, 30% TAP SPLIT, SINGLE	A8-TC-1-3-U LC-30-1
	ASCEND TAP CASSETTE, BASE-8, SM, LC/APC FRONT, 30% TAP SPLIT, SINGLE	A8-TC-1-3-ALC-30-1
	ASCEND TAP CASSETTE, BASE-8, MM, MTP FRONT, MTP REAR, 30% TAP SPLIT, SINGLE	A8-TC-4-1-XXX-30-1
	ASCEND TAP CASSETTE, BASE-8, MM, LC/PC FRONT, MTP REAR, 30% TAP SPLIT, SINGLE	A8-TC-4-2-PLC-30-1
	ASCEND TAP CASSETTE, BASE-8, MM, LC/PC FRONT, 30% TAP SPLIT, SINGLE	A8-TC-4-3-PLC-30-1
BASE-12	ASCEND TAP CASSETTE, BASE-12, SM, MTP FRONT, MTP REAR, 30% TAP SPLIT, SINGLE	A12-TC-1-1-XXX-30-1
	ASCEND TAP CASSETTE, BASE-12, SM, LC/UPC FRONT, MTP REAR, 30% TAP SPLIT, SINGLE	A12-TC-1-2-U LC-30-1
	ASCEND TAP CASSETTE, BASE-12, SM, LC/APC FRONT, MTP REAR, 30% TAP SPLIT, SINGLE	A12-TC-1-2-ALC-30-1
	ASCEND TAP CASSETTE, BASE-12, SM, LC/UPC FRONT, 30% TAP SPLIT, SINGLE	A12-TC-1-3-U LC-30-1
	ASCEND TAP CASSETTE, BASE-12, SM, LC/APC FRONT, 30% TAP SPLIT, SINGLE	A12-TC-1-3-ALC-30-1
	ASCEND TAP CASSETTE, BASE-12, MM, MTP FRONT, MTP REAR, 30% TAP SPLIT, SINGLE	A12-TC-4-1-XXX-30-1
	ASCEND TAP CASSETTE, BASE-12, MM, LC/PC FRONT, MTP REAR, 30% TAP SPLIT, SINGLE	A12-TC-4-2-PLC-30-1
	ASCEND TAP CASSETTE, BASE-12, MM, LC/PC FRONT, 30% TAP SPLIT, SINGLE	A12-TC-4-3-PLC-30-1

Qualifications

GOVERNING BODY	STANDARD CODE	COMPONENT
EIA/TIA	568	Connectors
ITU-T	G.652.D and G.657-A1	Single-mode Fiber
IEC	60793-2-10 Type A1	OM1, OM2, OM3, OM4 Multimode Fiber
Telcordia	GR-20	Fiber
	GR-1435	Connectors
RoHS	Compliant Directive 2001/65/EU	Fiber and Connectors



ASCEND® Patch Cord Assemblies

ASCEND patch cord assemblies are constructed with AFL's Micro Dual-Link cable and terminated with a field-reversible LC Uniboot connector.

This round cable design, coupled with the Uniboot LC connector, minimizes the front-side cabling footprint and reduces the impact on airflow up and down the rack, and between racks.

In addition to being field-reversible, the Uniboot LC connector also features an extended push-pull latching mechanism to improve finger access in high density applications.

Applications

- Data Centers
- Central Offices
- Headends
- Structured Cabling Networks

Features

- Uniboot LC connector comes pre-terminated with A to B polarity and is field-reversible
- No tools required
- Extended push-pull latching mechanism
- Round 2.0 mm plenum-rated jacket
- SM, MM (OM3) and MM (OM4)
- Bend insensitive fiber (G.657.A1)

Ordering Information

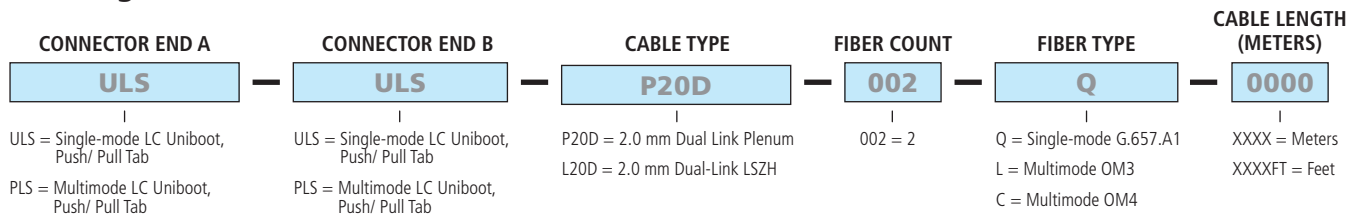

Specifications

PARAMETER	SM	MM
Insertion Loss (Typical)	0.10 dB	0.10 dB
Insertion Loss (Max)	0.30 dB	0.30 dB
Reflectance (Typical)	-55 dB	-30 dB
Durability	500 Cycles	
Operating Temperature	-40°C to +75°C	
Ferrule	Zirconia	

Qualifications

GOVERNING BODY	STANDARD CODE	COMPONENT
ITU	G.657.A1	Single-mode optical fiber only
Telcordia	GR-409	Cable
	GR-326	Connectors
RoHS	Compliant	Cable



Integrated mounting clip

ASCEND® Trunk Cable Assemblies

ASCEND trunk cable assemblies provide a high performance plug-and-play solution for premise installations where space is a premium.

The small-diameter MicroCore® cable construction provides industry leading fiber density and offers the installer many advantages over traditional cable options – higher tolerance to bends during and after installation; requires less space in cable trays, raceways, ducts and conduits; and enables more efficient airflow in congested, high density cabling applications.

ASCEND trunk cable assemblies feature the MTP® PRO* connector on multimode assemblies which allows for field-reversible polarity and gender with no housing removal, exposed fibers, or loose pins. All trunk cable assemblies have a predefined breakout length which eliminates guess-work and guarantees a clean and well-organized installation.

ASCEND trunk cable assemblies also include an integrated cable mounting clip, or "Outback Clip (OBC)" which mates directly with the trunk cable management area in the rear of all ASCEND housings. There are two Outback Clip options: the "Rock and Lock" which mates to the housing using a lever, and the "Hook and Loop" which mates to the housing using Velcro®. These clips eliminate the need for additional cable clamps and securely position the incoming cable while eliminating unwanted stress during installation.

NOTE: A separate external cable mounting bracket is required if non-ASCEND cable assemblies are going to be installed in ASCEND Fiber Housings.

Features

- 12-288 fibers in BASE-8 and BASE-12 configurations
- SM, MM (OM3) and MM (OM4)
- Bend-insensitive fiber (G.657.A1)
- Reduced-diameter MicroCore® cable with 2.0 mm subunits (up to 144)
- Plenum or LSZH options available
- Low loss MTP® PRO* connectors with field-reversible polarity and gender
- Single-mode terminations provided with Elite® performance
- Integrated cable mounting clip eliminates the requirement for external clamps for all ASCEND housings
- Pulling eye option available

Applications

- Data Centers
- Central Offices
- Headends
- Structured Cabling Networks

* MTP® PRO connectors are a trademark of US Conec (For MM connectors only)

ASCEND® Trunk Cable Assemblies

Specifications

CONNECTOR	Connector Ordering Code	Connector Housing Color	Fiber Type	Cable Jacket Color	IL (Typical dB)	IL (MAX. DB)	Reflectance (Typical dB)
8F MTP Elite (unpinned)	EEF	Yellow	Single-mode G.657.A1 (BIF)	Yellow	0.1	0.35	-60
8F MTP Elite (pinned)	EEM	Yellow	Single-mode G.657.A1 (BIF)	Yellow	0.1	0.35	-60
8F MTP Pro (unpinned)	PFEF	Aqua	50 µm OM3, OM4	Aqua	0.1	0.35	-20
8F MTP Pro (pinned)	PFEM	Aqua	50 µm OM3, OM4	Aqua	0.1	0.35	-20
12F MTP Elite (unpinned)	ETF	Yellow	Single-mode G.657.A1 (BIF)	Yellow	0.1	0.35	-60
12F MTP Elite (pinned)	ETM	Yellow	Single-mode G.657.A1 (BIF)	Yellow	0.1	0.35	-60
12F MTP Pro (unpinned)	PFTF	Aqua	50 µm OM3, OM4	Aqua	0.1	0.35	-20
12F MTP Pro (pinned)	PFTM	Aqua	50 µm OM3, OM4	Aqua	0.1	0.35	-20

Ordering Information

CONNECTOR END A — **CONNECTOR END B** — **CABLE TYPE** — **FIBER COUNT** — **FIBER TYPE** — **CABLE LENGTH** — **PULLING EYE** — **POLARITY** — **OBC** — **BASE SELECTION** — **PLATFORM**

ETF — **ETF** — **PL** — **012** — **Q** — **0001** — **PA** — **MF** — **RS** — **12** — **ASCEND**

EEF = MPO-SM Elite, 8 fiber, Female
 EEM = MPO-SM Elite, 8 fiber, Male
 PFEF = MTP PRO-MM, 8 fiber, Female
 PFEM = MTP PRO-MM, 8 fiber, Male
 ETF = MPO-SM Elite, 12 fiber, Female
 ETM = MPO-SM Elite, 12 fiber, Male
 PFTF = MTP PRO-MM, 12 fiber, Female
 PFTM = MTP PRO-MM, 12 fiber, Male
 XXX = No Connector (Pigtail)

Options for Trunk & Pigtail Assemblies:
 PL = Plenum MicroCore (250 µm)
 P4 = 4.8 mm Plenum MicroCore (for 12F cables only)
 GE = LSZH MicroCore (250 µm)
 Options for Pigtail Assemblies Only:
 GQS = 2.0 mm Plenum MicroCore (SWR)
 GES = 2.0 mm LSZH MicroCore (SWR)

008 = 8
 012 = 12
 024 = 24
 048 = 48
 072 = 72
 096 = 96
 144 = 144
 288 = 288

Q = Single-mode G.657A BIF
 L = Multimode OM3
 C = Multimode OM4

XXXX = Meters
 XXXXFT = Feet

N = No Pulling Eye
 PA = Pulling Eye End A
 PB = Pulling Eye End B
 PC = Pulling Eye Both Ends

MF = Method F
 MA = Method A

08 = BASE-8
 12 = BASE-12

ASCEND

HM = Hook & Loop OBC, Mixed
 HS = Hook & Loop OBC, Small
 HL = Hook & Loop OBC, Large
 RS = Rock & Lock*, Small
 NC = Spool Only
 Blank = Standard OBC

*** NOTE** – The "Rock and Lock" mounting clip is only available for trunk cable diameters up to 13 mm and will come standard on trunk cables with fiber counts up to 288. The "Hook and Loop" mounting clip is available by request only.

Qualifications

GOVERNING BODY	STANDARD CODE	COMPONENT
ITU	G.657.A1	Single-mode optical fiber only
Telcordia	GR-326/GR-1435	Connectors
	GR-409-CORE	Cable
EIA/TIA	568-A	Cable
RoHS	Compliant	Cable

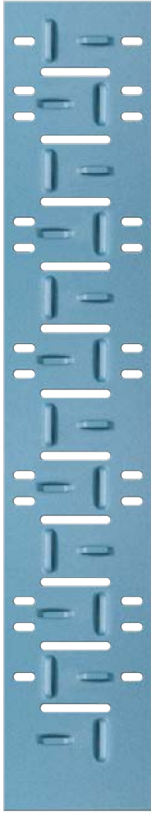

ASCEND® Outback Clip Management (OCM) Bracket

ASCEND trunk cable assemblies provide a high performance plug-and-play solution and come equipped with an integrated mounting clip or "Outback Clip." There are two Outback Clip options: the "Rock and Lock" which mates to the housing using a lever, and the "Hook and Loop" which mates to the housing using velcro. These clips eliminate the need for additional cable clamps and securely position the incoming cable while eliminating unwanted stress during installation.

Trunk cables with Outback Clips are typically mounted directly in the rear of ASCEND Housings; however for applications that require cable mounting on the rack itself, the ASCEND OCM Bracket is designed to efficiently accommodate up to 12 ASCEND trunk cable assemblies.

Features

- Accommodates up to 12 Outback Clips/ Trunk Cables
- Rugged steel construction
- Includes rack tap screws

Applications

- Data Centers
- Central Offices
- Headends
- Structured Cabling Networks

Ordering Information

CATEGORY	DESCRIPTION	AFL NO.
ASCEND Accessories	ASCEND, Outback Mounting Clip Bracket, 12 Positions	OCM-12

Qualifications

GOVERNING BODY	STANDARD CODE
RoHS	Compliant

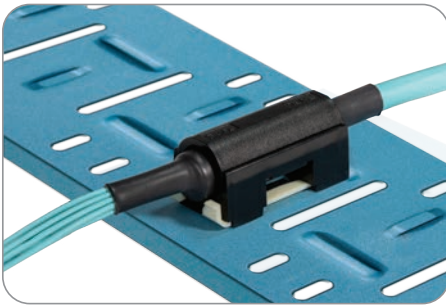

Integrated Mounting of "Outback Clip" on ASCEND trunk cable assemblies provide simple snap and push release tabs

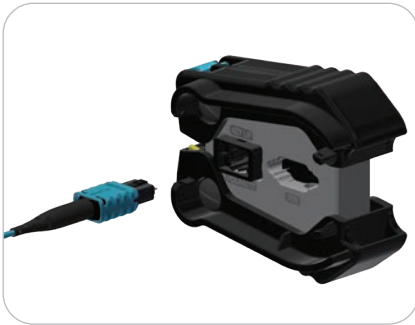

MTP® PRO Field Tool for Polarity/Pin Change

The unique MTP® PRO* design is focused on simplicity and reliability to ensure a quick and effective method for pin configuration without the need to remove the housing or handle loose pins.

Features

- Robust tool for easy pin change process
- Factory color designated pin clamp for easy identification
- Reusable color designated pin exchanger for safe handling of pins
- Field friendly configuration with no risk for damage
- Reliable pin retention force exceeding IEC requirement of 19.6N
- No handling of loose pins
- No housing removal necessary
- Compatible and recommended for use with ASCEND® Trunk Cable Jumper and Pigtail Assemblies whenever gender/ polarity changes are required in the field

Ordering Information

DESCRIPTION	AFL NO.
Field Tool, Polarity/Pin, MTP PRO (18814)	CS014748
Pin Exchanger, MTP Pro, Multimode, Female, Aqua, 10 pack (18256)	CS016089
Pin Exchanger, MTP Pro, Single-mode, Female, Yellow, 10 pack (18841)	CS016090
Pin Exchanger, MTP Pro, Multimode, Male, Aqua, 10 pack (18842)	CS016091
Pin Exchanger, MTP Pro, Single-mode, Male, Yellow, 10 pack (18843)	CS016092

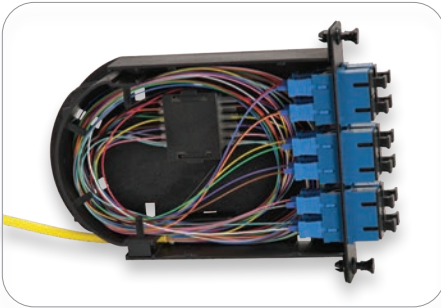

12-Fiber SC/UPC Configuration



24-Fiber LC/UPC Configuration



DAS Poli-MOD



Poli-MOD® Patch and Splice Module

AFL's new Poli-MOD is an innovative patch and splice module, which offers an inventive and effective means to accommodate up to 24 fiber interconnections in an industry-standard, single-slot LGX® 118 footprint. The Poli-MOD offers a unique and robust way to secure cable without the need for time-wasting, tie-wrap alternatives. Additionally, the module leverages a creative snap-in splice sleeve cradle to securely manage both single and ribbon fiber arrangements. These features provide the capacity to outfit a standard 4RU rack-mount panel with up to 288-fiber interconnections.

The Poli-MOD is also offered in an arrangement that supports the low loss budget requirements of Distributed Antenna System (DAS) networks. This is accomplished through the elimination of an interconnection point while providing a robust splicing environment for rack and wall-mount panel applications.

Features

- 24-fiber interconnection capacity
- LGX 118 compatibility (single-slot module)
- Effective and time-saving cable mounting mechanism (no tie-wraps necessary)
- Inventive splice sleeve cradle
- Available in SC, LC, ST and FC connector arrangements
- Shuttered LC connectors for increased dust protection
- Organized fiber routing
- Fixed solution, no moving parts
- Multi-directional cable entry access
- DIN rail mountable (with DIN Mount Kit)

Applications

- Telecommunications Closets
- Data Centers
- Customer Premise
- Local Area Networks
- Wide Area Networks
- Central Offices
- Hub Sites
- Cabinets
- Remote Terminals
- Distributed Antenna Systems (DAS)

LGX is a registered trademark of Furukawa Electric North America, Inc.

Poli-MOD® Patch and Splice Module

Ordering Information

Example: PM-L-12-ASC-0-S-01

PM	L	12	ASC	0	S	01
	Configuration	Fiber/Connector Count	Connector Type ³	Fiber Type	Fiber Arrangement	Packaging
	E = Empty (Splicing Only) H = Half Loaded (Adapter Plate only) L = Loaded (Adapter Plate & Pigtails) D = DAS Poli-MOD ¹	06 = 6 Fibers/Connectors 12 = 12 Fibers/Connectors 24 = 24 Fibers/Connectors ² XX = Empty	ASC = Angle-Polished SC USC = Ultra-Polished SC PSC = Multimode SC ALC = Angle-Polished LC ULC = Ultra-Polished LC PLC = Multimode LC UST = Ultra-Polished ST PST = Multimode ST AFC = Angle-Polished FC UFC = Ultra-Polished FC PFC = Multimode FC XXX = Empty	0 = Single-mode (G.657.A1 BIF) 1 = 62.5 μm (OM1) 2 = 50 μm (OM2) 3 = 50 μm (OM3) 4 = 50 μm (OM4) X = Empty	S = Single/Standard R = Ribbon 3 = 3 mm, 3 meter DAS W = SpiderWeb Ribbon® (SWR®) X = No Fiber (Half Loaded or Empty)	01 = 1 Poli-MOD per box* 06 = 6 Poli-MODs per box 12 = 12 Poli-MODs per box

- DAS Poli-MOD, with a maximum of 12 fibers each, requires specialty packaging and is packaged as "1 Poli-MOD per box" ONLY.
- 24 Fibers/Connectors are only available in a LC Duplex configuration.
- Angle and Ultra-Polished connector types are only available with single-mode fiber configurations.

Adapter Color Codes

FIBER AND POLISH TYPE	ADAPTER COLOR
Single-mode, APC (Angled Physical Contact)	Green
Single-mode, UPC (Ultra Physical Contact)	Blue
Multimode OM1, PC (Physical Contact)	Beige
Multimode OM2, PC (Physical Contact)	Black
Multimode OM4, PC (Physical Contact)	Aqua

Poli-MOD Kits/Accessories

DESCRIPTION	AFL NO.
Poli-MOD Cable Mounting Clip Kit	FM003053
Poli-MOD Spiral Wrap Kit	FM003280
Poli-MOD Splice Chip Kit with 24 Splice Sleeves	FM003711
Fusion Splice Sleeve, FP-03, 40 mm	S000206
Adapter Bracket for Mounting Single Poli-MOD, angled	FM00948-B
Adapter Bracket for Mounting Single Poli-MOD, flat	FM003589-B
Corning CCH and PCH 145 mm Adapter Bracket	FM001636
DIN Mount Kit, LGX® 118	FM003394

Dimensions

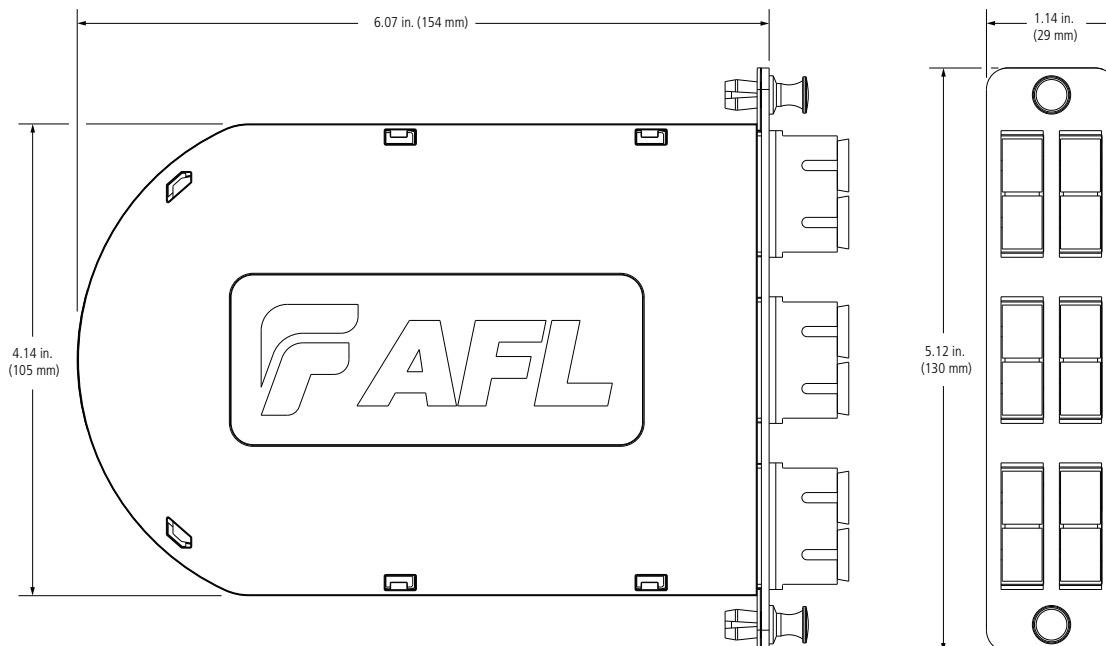



LightLink Adapter Plates

LightLink Adapter Plates add versatility to AFL's panel product line. Adapter plates are compatible with industry standard platforms allowing for easy upgrades to existing panels. Adapter Plates come preloaded with adapters and are available in 6, 8, 12 and 24 pack versions for single-fiber adapters. Higher fiber counts are achievable with multi-fiber adapters. Blank plates are also available for unused space in panels.

Features

- Metal Plate with Nylatches
- Polyurethane powder coated (white or black)
- LGX® compatible

Specifications

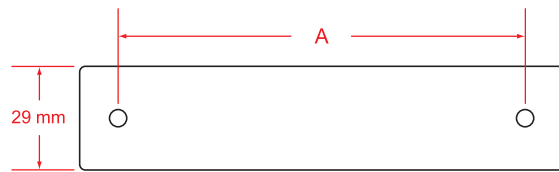

DIMENSION A
118 mm LGX®
170 mm LGX®

Ordering Information

AFL NO.	ADAPTER TYPE	SIMPLEX/DUPLEX/QUAD	ADAPTER COLOR	FIBER COUNT	PLATE HEIGHT	PLATE COLOR
BLANK						
FM003072	BLANK	BLANK	NA	0	LGX (118)	BLACK
FM003462	BLANK	BLANK	NA	0	LGX (118)	WHITE
FM000343	BLANK	BLANK	NA	0	LGX (118)	SMOOTH BLACK
FM003434	BLANK	BLANK	NA	0	LGX (170)	BLACK
FM003433	BLANK	BLANK	NA	0	LGX (170)	WHITE
SC						
FM003295	SC	DUPLEX	AQUA	12F	LGX (118)	BLACK
FM002272	SC	DUPLEX	AQUA	12F	LGX (118)	WHITE
FM003293	SC	DUPLEX	BEIGE	12F	LGX (118)	BLACK
FM002273	SC	DUPLEX	BEIGE	12F	LGX (118)	WHITE
FM003301	SC	DUPLEX	BLACK	12F	LGX (118)	BLACK
FM003297	SC	DUPLEX	BLUE	12F	LGX (118)	BLACK
FM002271	SC	DUPLEX	BLUE	12F	LGX (118)	WHITE
FM002633	SC	DUPLEX	GREEN	12F	LGX (118)	BLACK
FM002634	SC	DUPLEX	GREEN	12F	LGX (118)	WHITE
FM000149	SC	DUPLEX	BEIGE	12F	LGX (170)	WHITE
FM000148	SC	DUPLEX	BEIGE	12F	LGX (170)	BLACK
FM000144	SC	DUPLEX	BLUE	12F	LGX (170)	BLACK
FM000145	SC	DUPLEX	BLUE	12F	LGX (170)	WHITE
FM000152	SC	DUPLEX	GREEN	12F	LGX (170)	BLACK
FM000153	SC	DUPLEX	GREEN	12F	LGX (170)	WHITE
FM003287	SC	DUPLEX	AQUA	6F	LGX (118)	BLACK
FM003285	SC	DUPLEX	BEIGE	6F	LGX (118)	BLACK
FM003398	SC	DUPLEX	BEIGE	6F	LGX (118)	WHITE
FM003299	SC	DUPLEX	BLACK	6F	LGX (118)	BLACK
FM003289	SC	DUPLEX	BLUE	6F	LGX (118)	BLACK
FM003458	SC	DUPLEX	BLUE	6F	LGX (118)	WHITE
FM003283	SC	DUPLEX	GREEN	6F	LGX (118)	BLACK
FM000115	SC	DUPLEX	GREEN	6F	LGX (118)	WHITE

LGX is a registered trademark of Furukawa Electric North America, Inc.

LightLink Adapter Plates

Ordering Information (cont.)

AFL NO.	ADAPTER TYPE	SIMPLEX/DUPLEX/ QUAD	ADAPTER COLOR	FIBER COUNT	PLATE HEIGHT	PLATE COLOR
SC						
FM003120	SC	SIMPLEX	AQUA	12F	LGX (118)	BLACK
FM003118	SC	SIMPLEX	BEIGE	12F	LGX (118)	BLACK
FM003242	SC	SIMPLEX	BLACK	12F	LGX (118)	BLACK
FM003122	SC	SIMPLEX	BLUE	12F	LGX (118)	BLACK
FM002842-TW	SC	SIMPLEX	BLUE	12F	LGX (118)	WHITE
FM003116	SC	SIMPLEX	GREEN	12F	LGX (118)	BLACK
FM000800-TW	SC	SIMPLEX	GREEN	12F	LGX (118)	WHITE
FM003411	SC	SIMPLEX	BEIGE	12F	LGX (170)	WHITE
FM003409	SC	SIMPLEX	BLUE	12F	LGX (170)	BLACK
FM003407	SC	SIMPLEX	BLUE	12F	LGX (170)	WHITE
FM003414	SC	SIMPLEX	GREEN	12F	LGX (170)	BLACK
FM003455	SC	SIMPLEX	GREEN	12F	LGX (170)	WHITE
FM003098	SC	SIMPLEX	AQUA	6F	LGX (118)	BLACK
FM003096	SC	SIMPLEX	BEIGE	6F	LGX (118)	BLACK
FM003403	SC	SIMPLEX	BEIGE	6F	LGX (118)	WHITE
FM003238	SC	SIMPLEX	BLACK	6F	LGX (118)	BLACK
FM003100	SC	SIMPLEX	BLUE	6F	LGX (118)	BLACK
FM003467	SC	SIMPLEX	BLUE	6F	LGX (118)	WHITE
FM003094	SC	SIMPLEX	GREEN	6F	LGX (118)	BLACK
FM000480	SC	SIMPLEX	GREEN	6F	LGX (118)	WHITE
FM000156	SC	SIMPLEX	BLUE	8F	LGX (118)	BLACK
FM003435	SC	SIMPLEX	BLUE	8F	LGX (118)	WHITE
FM002841	SC	SIMPLEX	GREEN	8F	LGX (118)	BLACK
FM000158	SC	SIMPLEX	GREEN	8F	LGX (118)	WHITE
LC						
FM001004	LC	DUPLEX	GREEN	12F	LGX (118)	WHITE
FM001303	LC	DUPLEX	AQUA	12F	LGX (118)	WHITE
FM003108	LC	DUPLEX	GREEN	12F	LGX (118)	BLACK
FM003110	LC	DUPLEX	BEIGE	12F	LGX (118)	BLACK
FM003112	LC	DUPLEX	AQUA	12F	LGX (118)	BLACK
FM001185	LC	QUAD	AQUA	12F	LGX (118)	BLACK
FM000297	LC	DUPLEX	BLUE	12F	LGX (170)	WHITE
FM000298	LC	DUPLEX	BLUE	12F	LGX (170)	BLACK
FM000301	LC	DUPLEX	GREEN	12F	LGX (170)	WHITE
FM000302	LC	DUPLEX	GREEN	12F	LGX (170)	BLACK
FM000838	LC	DUPLEX	BLUE	24F	LGX (118)	WHITE
FM000851	LC	DUPLEX	BEIGE	24F	LGX (118)	WHITE
FM000853	LC	DUPLEX	AQUA	24F	LGX (118)	WHITE
FM003069	LC	DUPLEX	GREEN	24F	LGX (118)	WHITE
FM001184	LC	QUAD	AQUA	24F	LGX (118)	BLACK
FM000129	LC	DUPLEX	BLUE	24F	LGX (170)	WHITE
FM000130	LC	DUPLEX	BLUE	24F	LGX (170)	BLACK
FM000338	LC	DUPLEX	GREEN	24F	LGX (170)	WHITE
FM000339	LC	DUPLEX	GREEN	24F	LGX (170)	BLACK
FM000348	LC	DUPLEX	BEIGE	24F	LGX (170)	WHITE
FM000349	LC	DUPLEX	BEIGE	24F	LGX (170)	BLACK
FM000289	LC	DUPLEX	BLUE	6F	LGX (118)	WHITE
FM000293	LC	DUPLEX	GREEN	6F	LGX (118)	WHITE
FM000294	LC	DUPLEX	GREEN	6F	LGX (118)	BLACK
FM003092	LC	DUPLEX	BLUE	6F	LGX (118)	BLACK
FM003429	LC	DUPLEX	BEIGE	6F	LGX (118)	WHITE
FM004252	LC	DUPLEX	AQUA	6F	LGX (118)	BLACK

LightLink Adapter Plates

Ordering Information (cont.)

AFL NO.	ADAPTER TYPE	SIMPLEX/DUPLEX/ QUAD	ADAPTER COLOR	FIBER COUNT	PLATE HEIGHT	PLATE COLOR
LC						
FM003240	LC	DUPLEX	BLACK	12F	LGX (118)	BLACK
FM003425	LC	DUPLEX	BLUE	12F	LGX (118)	WHITE
FM003465	LC	DUPLEX	BLUE	12F	LGX (118)	BLACK
FM003202	LC	DUPLEX	GREEN	24F	LGX (118)	BLACK
FM003204	LC	DUPLEX	BEIGE	24F	LGX (118)	BLACK
FM003206	LC	DUPLEX	AQUA	24F	LGX (118)	BLACK
FM003208	LC	DUPLEX	BLUE	24F	LGX (118)	BLACK
FM003244	LC	DUPLEX	BLACK	24F	LGX (118)	BLACK
ST						
FM003126	ST	SIMPLEX	METAL SM/MM	12F	LGX (118)	BLACK
FM003456	ST	SIMPLEX	METAL SM/MM	12F	LGX (118)	WHITE
FM000286	ST	SIMPLEX	METAL SM/MM	12F	LGX (170)	BLACK
FM000285	ST	SIMPLEX	METAL SM/MM	12F	LGX (170)	WHITE
FM003104	ST	SIMPLEX	METAL SM/MM	6F	LGX (118)	BLACK
FM003422	ST	SIMPLEX	METAL SM/MM	6F	LGX (118)	WHITE
FM003102	ST	SIMPLEX	METAL SM/MM	6F	LGX (118)	BLACK
FM003441	ST	SIMPLEX	METAL SM/MM	8F	LGX (118)	BLACK
FM003439	ST	SIMPLEX	METAL SM/MM	8F	LGX (118)	WHITE
FC						
FM000284	FC	SIMPLEX	METAL	12F	LGX (118)	BLACK
FM000283	FC	SIMPLEX	METAL	12F	LGX (118)	WHITE
FM003447	FC	SIMPLEX	METAL	12F	LGX (170)	BLACK
FM003446	FC	SIMPLEX	METAL	12F	LGX (170)	WHITE
FM003420	FC	SIMPLEX	METAL, GREEN DUST CAP	6F	LGX (118)	BLACK
FM003419	FC	SIMPLEX	METAL, GREEN DUST CAP	6F	LGX (118)	WHITE
FM003443	FC	SIMPLEX	METAL	8F	LGX (118)	BLACK
FM003442	FC	SIMPLEX	METAL	8F	LGX (118)	WHITE
MISC						
FM003210	HEYCO	SIMPLEX	BLACK	12F	LGX (118)	BLACK
FM003430	MTP	SIMPLEX	BLACK	36F	LGX (118)	BLACK
FM003212	HEYCO	SIMPLEX	BLACK	6F	LGX (118)	BLACK
FM003437	SC-ST HYBRID	SIMPLEX	BLUE-METAL	6F	LGX (118)	WHITE
FM001606	MTP	SIMPLEX	BLACK	72F	LGX (118)	BLACK
FM003005	MTP	SIMPLEX	BLACK	96F	LGX (118)	BLACK

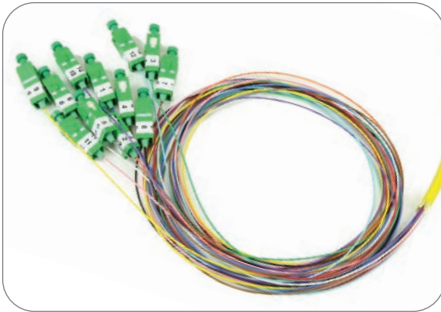

Pigtail Assemblies for Patch and Splice Panels

AFL's pigtail assemblies help eliminate labor-intensive field termination, yet guarantee reliable performance. Featuring a unified construction allowing for easy fiber identification and rapid installation, these assemblies are built to exceed all TIA and Telcordia® requirements.

Ordering Information

POLISH	FIBER TYPE	CONNECTOR INTERFACE AFL NO.		
		SC	ST	LC
CPC PIGTAIL KITS, 3 METER, 12-FIBER				
APC	SMF	C152906-0003	—	CS007719-0003
UPC	SMF	C165943-0003	C152671-0003	C223369-0003
PC	62.5 μm	C165463-0003	C223366-0003	C223373-0003
PC	50 μm LO	CS007673-0003	CS007675-0003	CS007677-0003

900 μm TIGHT-BUFFERED PIGTAIL KITS, 3 METER, 12-FIBER				
APC	SMF	C223312-0003	—	CS002951-0003
UPC	SMF	C223492-0003	CS003979-0003	CS001037-0003
PC	62.5 μm	CS000386-0003	CS002150-0003	CS002067-0003
PC	50 μm LO	CS003056-0003	CS003980-0003	CS003058-0003

Specifications

PARAMETER		VALUE					
		LC	SC	ST	FC	LC-APC	SC-APC
Insertion Loss							
SM	MAX	0.3	0.3	0.5	0.3	0.3	0.5
MM	MAX	0.5	0.5	0.5	0.5		
Return Loss							
SM	MIN	-55.0 dB	-55.0 dB	-55.0 dB	-55.0 dB	-65.0 dB	-65.0 dB
MM	MIN	-20.0 dB					
Cable Bend Radius							
Bend Insensitive	MIN	<15 mm					
Operating Temperature		0°C to +70°C					

Qualifications

GOVERNING BODY	STANDARD CODE	COMPONENT
Telcordia	GR-409	Cable
TIA	GR-326	Connector
ITU	G.652-D, G.657-A1	Single-mode Optical Fiber Only



WME01

Wall Mount Interconnect Enclosure (WME) with One LGX® Mounting Position

AFL's wall mount interconnect enclosure (WME01) provides a convenient convergence point for interconnecting and/or splicing in wall mount applications. Provisioned for one LGX-compatible adapter plate or optical module, the enclosure features a well-engineered solution for fiber and cable management on both the top and bottom openings of the enclosure. Robust steel construction ensures the highest level of protection for sensitive components while integrated roll-formed hinges eliminate possible fiber pinch points. The WME01 features a front access door which is lockable with a common pad-lock or tube-style keyed lock.

Features

- Fits comfortably into new and existing interconnect, cross-connect and co-location environments
- U-shaped cable entry eliminates the need to feed preconnectorized cables through an inconvenient access port
- Modular design fully compatible with Poli-MOD® products and XFM® optical cassettes
- Locking option for flexibility and security
- Available empty, with adapters, or with adapters, splice chip and pigtails pre-installed
- LGX 118 compatible
- Optional DIN rail mounting kit (sold separately)
- All major connector types are supported



WME01 rear mounting clip for DIN rail

Applications

- Co-Location sites
- Customer premise
- Hub/OTN sites
- Telecommunication closets
- Campus/enterprise environments

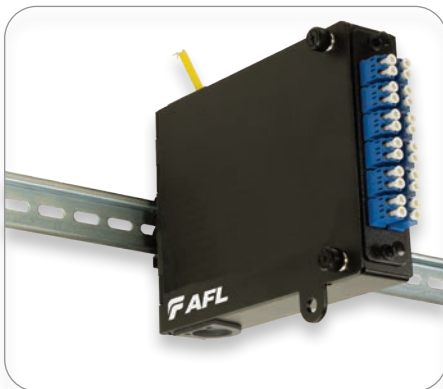

WME01 with DIN rail mounting kit

Specifications

- Solid steel construction
- Powder coat black textured finish
- Top or bottom cable entry with dust resistant grommets
- Single-hasp locking/security system
- 12 to 24 fiber patch and splice density
- One LGX mounting position
- Physical dimensions: 5.6" H x 7" W x 1.5" D
- Empty version weight: 2.0 lbs.

LGX is a registered trademark of Furukawa Electric North America, Inc.

Wall Mount Interconnect Enclosure (WME) with One LGX® Mounting Position

Ordering Information

EMPTY	
DESCRIPTION	AFL NO.
WME01 Empty	WME01E

HALF LOADED: WME WITH ADAPTER PLATES AND ADAPTERS ONLY							
CONN. TYPE	FIBER CT.	AFL NO.					
		UPC SM (BLUE)	APC SM (GREEN)	PC MM 62.5 (BEIGE)	PC MM 50 (BLACK)	PC MM OM3 (AQUA)	PC MM OM4 (AQUA)
SC	6	WME01AS-USCSM-006000	WME01AS-ASCSM-006000	WME01AS-PSCM6-006000	WME01AS-PSCM5-006000	WME01AS-PSCML-006000	WME01AS-PSCMC-006000
	12	WME01AS-USCSM-012000	WME01AS-ASCSM-012000	WME01AS-PSCM6-012000	WME01AS-PSCM5-012000	WME01AS-PSCML-012000	WME01AS-PSCMC-012000
LC	6	WME01AS-UDLSM-006000	WME01AS-ADLSM-006000	WME01AS-PDLM6-006000	WME01AS-PDLM5-006000	WME01AS-PDML-006000	WME01AS-PDLMC-006000
	12	WME01AS-UDLSM-012000	WME01AS-ADLSM-012000	WME01AS-PDLM6-012000	WME01AS-PDLM5-012000	WME01AS-PDML-012000	WME01AS-PDLMC-012000
	24	WME01AH-UDLSM-024000	WME01AH-ADLSM-024000	WME01AH-PDLM6-024000	WME01AH-PDLM5-024000	WME01AH-PDML-024000	WME01AH-PDLMC-024000
ST	6	WME01AS-USTSM-006000	—	WME01AS-PSTM6-006000	WME01AS-PSTM5-006000	WME01AS-PTML-006000	WME01AS-PTMC-006000
	12	WME01AS-USTSM-012000	—	WME01AS-PSTM6-012000	WME01AS-PSTM5-012000	WME01AS-PTML-012000	WME01AS-PTMC-012000
FC	6	WME01AS-UFCSM-006000	WME01AS-AFCSM-006000	WME01AS-PFCM6-006000	WME01AS-PFCM5-006000	WME01AS-PFCML-006000	WME01AS-PFCMC-006000
	12	WME01AS-UFCSM-012000	WME01AS-AFCSM-012000	WME01AS-PFCM6-012000	WME01AS-PFCM5-012000	WME01AS-PFCML-012000	WME01AS-PFCMC-012000

LOADED: WME WITH ADAPTER PLATES/ADAPTERS/SPLICE CHIP/PIGTAIL (900 µm TIGHT BUFFERED FIBERS 3 METERS IN LENGTH)							
CONN. TYPE	FIBER CT.	AFL NO.					
		UPC SM (BLUE)	APC SM (GREEN)	PC MM 62.5 (BEIGE)	PC MM 50 (BLACK)	PC MM OM3 (AQUA)	PC MM OM4 (AQUA)
SC	6	WME01FS-USCSM-0061C0	WME01FS-ASCSM-0061C0	WME01FS-PSCM6-0061C0	WME01FS-PSCM5-0061C0	WME01FS-PSCML-0061C0	WME01FS-PSCMC-0061C0
	12	WME01FS-USCSM-0121C0	WME01FS-ASCSM-0121C0	WME01FS-PSCM6-0121C0	WME01FS-PSCM5-0121C0	WME01FS-PSCML-0121C0	WME01FS-PSCMC-0121C0
LC	6	WME01FS-UDLSM-0061C0	WME01FS-ADLSM-0061C0	WME01FS-PDLM6-0061C0	WME01FS-PDLM5-0061C0	WME01FS-PDML-0061C0	WME01FS-PDLMC-0061C0
	12	WME01FS-UDLSM-0121C0	WME01FS-ADLSM-0121C0	WME01FS-PDLM6-0121C0	WME01FS-PDLM5-0121C0	WME01FS-PDML-0121C0	WME01FS-PDLMC-0121C0
	24	WME01FH-UDLSM-0241C0	WME01FH-ADLSM-0241C0	WME01FH-PDLM6-0241C0	WME01FH-PDLM5-0241C0	WME01FH-PDML-0241C0	WME01FH-PDLMC-0241C0
ST	6	WME01FS-USTSM-0061C0	—	WME01FS-PSTM6-0061C0	WME01FS-PSTM5-0061C0	WME01FS-PTML-0061C0	WME01FS-PTMC-0061C0
	12	WME01FS-USTSM-0121C0	—	WME01FS-PSTM6-0121C0	WME01FS-PSTM5-0121C0	WME01FS-PTML-0121C0	WME01FS-PTMC-0121C0
FC	6	WME01FS-UFCSM-0061C0	WME01FS-AFCSM-0061C0	WME01FS-PFCM6-0061C0	WME01FS-PFCM5-0061C0	WME01FS-PFCML-0061C0	WME01FS-PFCMC-0061C0
	12	WME01FS-UFCSM-0121C0	WME01FS-AFCSM-0121C0	WME01FS-PFCM6-0121C0	WME01FS-PFCM5-0121C0	WME01FS-PFCML-0121C0	WME01FS-PFCMC-0121C0

ACCESSORIES	
DESCRIPTION	AFL NO.
DIN Mount Kit, LGX® 118 (Nylon DIN Clips and Screws)	FM003388

Connector/Adapter Key

TYPE	DESCRIPTION
ASC	Angle Polish SC (ZR) sleeve-SM
ASF	Angle Polish SC Duplex (ZR) sleeve-SM
PSC	Physical Polish SC (PB) sleeve-MM
PSF	Physical Polish SC Duplex (PB) sleeve-MM
USC	Ultra Polish SC with (ZR) sleeve-SM
USF	Ultra Polish SC Duplex (ZR) sleeve-SM

TYPE	DESCRIPTION
PST	Physical Polish ST (PB) sleeve-MM
UST	Ultra Polish ST (ZR) sleeve-SM
AFC	Angle Polish FC (ZR) sleeve-SM
PFC	Physical Polish FC (PB) sleeve-MM
UFC	Ultra Polish FC (ZR) sleeve-SM

TYPE	DESCRIPTION
ADL	Angle Polish LC Duplex (ZR) sleeve-SM
PDL	Physical Polish LC Duplex (PB) sleeve-MM
PLC	Physical Polish LC (PB) sleeve-MM
UDL	Ultra Polish LC Duplex (ZR) sleeve-SM
ULC	Ultra Polish LC (ZR) sleeve-SM

LGX is a registered trademark of Furukawa Electric North America, Inc.



WME-02



WME-02 shown empty



WME-02 shown fully loaded

Wall Mount Interconnect Enclosure (WME) with Two LGX® Mounting Positions

AFL's wall mount interconnect enclosure (WME02) provides a convenient convergence point for interconnecting and/or splicing in wall mount applications. Provisioned for up to two LGX compatible adapter plates or optical modules, the enclosure features a well-engineered solution for fiber and cable management on both the ingress and egress openings of the enclosure. Robust steel construction ensures the highest level of protection for sensitive components while integrated roll-formed hinges eliminate possible fiber pinch points while deploying or servicing components within. The WME02 features discrete access doors for provider and customer access which are independently lockable with a common pad-lock or tube-style keyed lock.

Features

- Fits comfortably into new and existing interconnect, cross-connect and co-location environments
- U-shaped cable entry eliminates the need to feed preconnectorized cables through an inconvenient access port
- Modular design fully compatible with Poli-MOD® products and XFM optical cassettes
- Dual doors with separate locking options for flexibility and security
- Available empty, with adapters, or with adapters, splice trays and pigtails pre-installed
- LGX 118 compatible
- Optional splice tray and holder (ordered separately)
- All major connector types are supported

Applications

- Co-Location sites
- Customer premise
- Hub/OTN sites
- Telecommunication closets
- Campus/enterprise environments

Specifications

- Solid steel construction
- Powder coat black textured finish
- Top or bottom cable entry with dust resistant grommets
- Dual-hasp locking/security system
- 12 to 24 fiber patch and splice density
- Two LGX mounting positions
- Physical dimensions: 12.0"H x 14.0"W x 2.5"D
- Empty version weight: 10.65 lbs.

LGX is a registered trademark of Furukawa Electric North America, Inc.

Wall Mount Interconnect Enclosure (WME) with Two LGX® Mounting Positions

Ordering Information

EMPTY	
DESCRIPTION	AFL NO.
WME02 Empty	WME02E

HALF LOADED: WME WITH ADAPTER PLATES AND ADAPTERS ONLY				
CONNECTOR TYPE	FIBER COUNT	AFL NO.		
		UPC SM (BLUE)	APC SM (GREEN)	PC MM (BEIGE)
SC	6	WME02AS-USCSM-006000	WME02AS-ASCSM-006000	WME02AS-PSCM6-006000
	12	WME02AS-USCSM-012000	WME02AS-ASCSM-012000	WME02AS-PSCM6-012000
	24	WME02AH-USFSM-024000	WME02AH-ASFSM-024000	WME02AH-PSFM6-024000
LC	6	WME02AS-UDLSM-006000	WME02AS-ADLSM-006000	WME02AS-PDLM6-006000
	12	WME02AS-UDLSM-012000	WME02AS-ADLSM-012000	WME02AS-PDLM6-012000
	24	WME02AH-UDLSM-024000	WME02AH-ADLSM-024000	WME02AH-PDLM6-024000
ST	6	WME02AS-USTSM-006000	—	WME02AS-PSTM6-006000
	12	WME02AS-USTSM-012000	—	WME02AS-PSTM6-012000
	24	WME02AH-USTSM-024000	—	WME02AH-PSTM6-024000
FC	6	WME02AS-UFCSM-006000	WME02AS-AFCSM-006000	WME02AS-PFCM5-006000
	12	WME02AS-UFCSM-012000	WME02AS-AFCSM-012000	WME02AS-PFCM5-012000
	24	WME02AH-UFCSM-024000	WME02AH-AFCSM-024000	WME02AH-PFCM5-024000

Connector/Adapter Key

TYPE	DESCRIPTION
ASC	Angle Polish SC (ZR) sleeve-SM
ASF	Angle Polish SC Duplex (ZR) sleeve-SM
PSC	Physical Polish SC (PB) sleeve-MM
PSF	Physical Polish SC Duplex (PB) sleeve-MM
USC	Ultra Polish SC with (ZR) sleeve-SM
USF	Ultra Polish SC Duplex (ZR) sleeve-SM
PST	Physical Polish ST (PB) sleeve-MM
UST	Ultra Polish ST (ZR) sleeve-SM
AFC	Angle Polish FC (ZR) sleeve-SM
PFC	Physical Polish FC (PB) sleeve-MM
UFC	Ultra Polish FC (ZR) sleeve-SM
ADL	Angle Polish LC Duplex (ZR) sleeve-SM
PDL	Physical Polish LC Duplex (PB) sleeve-MM
PLC	Physical Polish LC (PB) sleeve-MM
UDL	Ultra Polish LC Duplex (ZR) sleeve-SM
ULC	Ultra Polish LC (ZR) sleeve-SM

LOADED: WME WITH ADAPTER PLATES/ADAPTERS/SPLICE TRAYS/PIGTAIL (900 μm TIGHT BUFFERED FIBERS 3 METERS IN LENGTH)					
CONNECTOR TYPE	FIBER COUNT	AFL NO.			
		UPC SM (BLUE)	APC SM (GREEN)	PC MM 62.5 μm (BEIGE)	PC MM 50 μm (BLACK)
SC	6	WME02FS-USCSM-006110	WME02FS-ASCSM-006110	WME02FS-PSCM6-006110	WME02FS-PSCM5-006110
	12	WME02FS-USCSM-012110	WME02FS-ASCSM-012110	WME02FS-PSCM6-012110	WME02FS-PSCM5-012110
	24	WME02FH-USFSM-024120	WME02FH-ASFSM-024120	WME02FH-PSFM6-024120	WME02FH-PSFM5-024120
LC	6	WME02FS-UDLSM-006110	WME02FS-ADLSM-006110	WME02FS-PDLM6-006110	WME02FS-PDLM5-006110
	12	WME02FS-UDLSM-012110	WME02FS-ADLSM-012110	WME02FS-PDLM6-012110	WME02FS-PDLM5-012110
	24	WME02FH-UDLSM-024120	WME02FH-ADLSM-024120	WME02FH-PDLM6-024120	WME02FH-PDLM5-024120
ST	6	WME02FS-USTSM-006110	—	WME02FS-PSTM6-006110	WME02FS-PSTM5-006110
	12	WME02FS-USTSM-012110	—	WME02FS-PSTM6-012110	WME02FS-PSTM5-012110
	24	WME02FH-USTSM-024120	—	WME02FH-PSTM6-024120	WME02FH-PSTM5-024120
FC	6	WME02FS-UFCSM-006110	WME02FS-AFCSM-006110	WME02FS-PFCM6-006110	WME02FS-PFCM5-006110
	12	WME02FS-UFCSM-012110	WME02FS-AFCSM-012110	WME02FS-PFCM6-012110	WME02FS-PFCM5-012110
	24	WME02FH-UFCSM-024120	WME02FH-AFCSM-024120	WME02FH-PFCM6-024120	WME02FH-PFCM5-024120

ACCESSORIES	
DESCRIPTION	AFL NO.
Splice Tray Kit: Single Fusion 12F, 2RU, WME02, WME04, 1 Splice Tray	FM002827-1
Splice Tray Kit: Single Fusion 12F, 2RU, WME02, WME04, 2 Splice Trays	FM002827-2

LGX is a registered trademark of Furukawa Electric North America, Inc.



WME-04



WME-04 shown empty



WME-04 shown fully loaded

Wall Mount Interconnect Enclosure (WME) with Four LGX® Mounting Positions

AFL's wall mount interconnect enclosure (WME04) provides a convenient convergence point for interconnecting and/or splicing in wall mount applications. Provisioned for up to four LGX compatible adapter plates or optical modules, the enclosure features a well-engineered solution for fiber and cable management on both the ingress and egress openings of the enclosure. Robust steel construction ensures the highest level of protection for sensitive components while integrated roll-formed hinges eliminate possible fiber pinch points while deploying or servicing components within. The WME04 features discrete access doors for provider and customer access which are independently lockable with a common pad-lock or tube-style keyed lock.

Features

- Fits comfortably into new and existing interconnect, cross-connect and co-location environments
- U-shaped cable entry eliminates the need to feed preconnectorized cables through an inconvenient access port
- Modular design fully compatible with Poli-MOD® products and XFM optical cassettes
- Dual doors with separate locking options for flexibility and security
- Available empty, with adapters, or with adapters, splice trays and pigtails pre-installed
- LGX 118 compatible
- Optional splice tray and holder (ordered separately)
- All major connector types are supported

Applications

- Co-Location sites
- Customer premise
- Hub/OTN sites
- Telecommunication closets
- Campus/enterprise environments

Specifications

- Solid steel construction
- Powder coat black textured finish
- Top or bottom cable entry with dust resistant grommets
- Dual-hasp locking/security system
- 24 to 48 fiber patch and splice density
- Four LGX mounting positions
- Physical dimensions: 12.0" H x 16.0" W x 3.63" D

Wall Mount Interconnect Enclosure (WME) with Four LGX® Mounting Positions

Ordering Information

EMPTY	
DESCRIPTION	AFL NO.
WME04 Empty	WME04E

HALF LOADED: WME WITH ADAPTER PLATES AND ADAPTERS ONLY				
CONNECTOR TYPE	FIBER COUNT	AFL NO.		
		UPC SM (BLUE)	APC SM (GREEN)	PC MM (BEIGE)
SC	24	WME04AS-USCSM-024000	WME04AS-ASCSM-024000	WME04AS-PSCM6-024000
	48	WME04AH-USFSM-048000	WME04AH-ASFSM-048000	WME04AH-PSFM6-048000
LC	24	WME04AS-UDLSM-024000	WME04AS-ADLSM-024000	WME04AS-PDLM6-024000
	48	WME04AH-UDLSM-048000	WME04AH-ADLSM-048000	WME04AH-PDLM6-048000
ST	24	WME04AS-USTSM-024000	—	WME04AS-PSTM6-024000
	48	WME04AH-USTSM-048000	—	WME04AH-PSTM6-048000
FC	24	WME04AS-UFCSM-024000	WME04AS-AFCSM-024000	WME04AS-PFCM5-024000
	48	WME04AH-UFCSM-048000	WME04AH-AFCSM-048000	WME04AH-PFCM5-048000

Connector/Adapter Key

TYPE	DESCRIPTION
ASC	Angle Polish SC (ZR) sleeve-SM
ASF	Angle Polish SC Duplex (ZR) sleeve-SM
PSC	Physical Polish SC (PB) sleeve-MM
PSF	Physical Polish SC Duplex (PB) sleeve-MM
USC	Ultra Polish SC with (ZR) sleeve-SM
USF	Ultra Polish SC Duplex (ZR) sleeve-SM
PST	Physical Polish ST (PB) sleeve-MM
UST	Ultra Polish ST (ZR) sleeve-SM
AFC	Angle Polish FC (ZR) sleeve-SM
PFC	Physical Polish FC (PB) sleeve-MM
UFC	Ultra Polish FC (ZR) sleeve-SM
ADL	Angle Polish LC Duplex (ZR) sleeve-SM
PDL	Physical Polish LC Duplex (PB) sleeve-MM
PLC	Physical Polish LC (PB) sleeve-MM
UDL	Ultra Polish LC Duplex (ZR) sleeve-SM
ULC	Ultra Polish LC (ZR) sleeve-SM

LOADED: WME WITH ADAPTER PLATES/ADAPTERS/SPLICE TRAYS/PIGTAIL (900 μm TIGHT BUFFERED FIBERS 3 METERS IN LENGTH)					
CONNECTOR TYPE	FIBER COUNT	AFL NO.			
		UPC SM (BLUE)	APC SM (GREEN)	PC MM 62.5 μm (BEIGE)	PC MM 50 μm (BLACK)
SC	24	WME04FS-USCSM-024120	WME04FS-ASCSM-024120	WME04FS-PSCM6-024120	WME04FS-PSCM5-024120
	48	WME04FH-USFSM-048140	WME04FH-ASFSM-048140	WME04FH-PSFM6-048140	WME04FH-PSFM5-048140
LC	24	WME04FS-UDLSM-024120	WME04FS-ADLSM-024120	WME04FS-PDLM6-024120	WME04FS-PDLM5-024120
	48	WME04FH-UDLSM-048140	WME04FH-ADLSM-048140	WME04FH-PDLM6-048140	WME04FH-PDLM5-048140
ST	24	WME04FS-USTSM-024120	—	WME04FS-PSTM6-024120	WME04FS-PSTM5-024120
	48	WME04FH-USTSM-048140	—	WME04FH-PSTM6-048140	WME04FH-PSTM5-048140
FC	24	WME04FS-UFCSM-024120	WME04FS-AFCSM-024120	WME04FS-PFCM6-024120	WME04FS-PFCM5-024120
	48	WME04FH-UFCSM-048140	WME04FH-AFCSM-048140	WME04FH-PFCM6-048140	WME04FH-PFCM5-048140

ACCESSORIES	
DESCRIPTION	AFL NO.
Splice Tray Kit: Single Fusion 12F, 2RU, WME02, WME04, 3 Splice Trays	FM002827-3
Splice Tray Kit: Single Fusion 12F, 2RU, WME02, WME04, 4 Splice Trays	FM002827-4

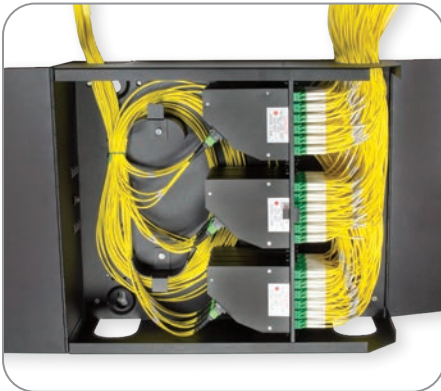

Wall Mount Interconnect Enclosure (WME) with 12 LGX® Mounting Positions

AFL's wall mount interconnect enclosure (WME12) provides a convenient convergence point for interconnecting and/or splicing in wall mount applications. Provisioned for up to 12 LGX-compatible optical modules, the enclosure features a well-engineered solution for fiber and cable management on both the ingress and egress openings of the enclosure. Robust steel construction ensures the highest level of protection for sensitive components while integrated roll-formed hinges eliminate possible fiber pinch points while deploying or servicing components within. The WME12 features discrete access doors for provider and customer access which are lockable by key.

Features

- Fits comfortably into new and existing interconnect, cross-connect and co-location environments
- U-shaped cable entry
- Modular design fully compatible with Poli-MOD® products and Xpress® Fiber Management (XFM®) optical cassettes
- Dual doors with separate locking options for flexibility and security
- LGX 118 compatible

Applications

- Co-Location sites
- Customer premise
- Hub/OTN sites
- Telecommunication closets
- Campus/enterprise environments

Specifications

- Solid steel construction
- Powder coat black textured finish
- Top or bottom cable entry with dust resistant grommets
- Keyed locking/security system
- Up to 288 fiber density
- 12 LGX mounting positions
- Physical dimensions: 16.75"H x 20.0"W x 6.82"D

Ordering Information

DESCRIPTION	AFL NO.
WME12 Empty	WME12E



OEE-288/576 Optical Entrance Enclosures



LightLink Optical Entrance Enclosures

The Optical Entrance Enclosures (OEE) are designed to provide a convenient splicing and interconnection location for outside plant cabling entering a Central Office (CO), Controlled Environmental Vault (CEV) or customer location. Each unit is designed to allow the entrance and management of up to 60 cables for splicing and interconnecting. Cables from termination locations and the outside plant are easily installed and managed. Access to individual fiber splices and fiber bundles are made easy by splice tray and fiber management designs.

Features

- Manages multiple cable enter and exit facilities
- Each fiber splice tray (sold separately) handles up to 48 single fusion or 144 mass fusion splices
- Enclosures for indoor or outdoor applications
- Internal ground bar and pass through ground lugs

Specifications

PARAMETER	VALUE
Material	Aluminum or steel
Coatings	Electrostatically applied, powder coat
Color	Granite
Dimensions	See Detail Drawings on following page

Accessories – Shingle Kits

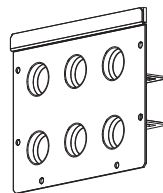

Standard Footprint 6 Ports

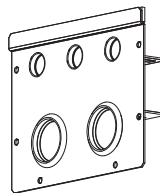

Standard Footprint 5 Ports

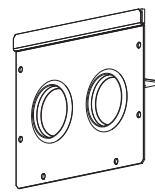

Standard Footprint 2 Ports - XL

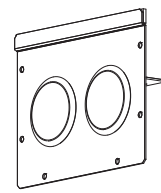

Standard Footprint 2 Ports - XXL



OEE-720/1440 Optical Entrance Enclosures



continued
→

LightLink Optical Entrance Enclosures

Dimensions

OEE 288/576

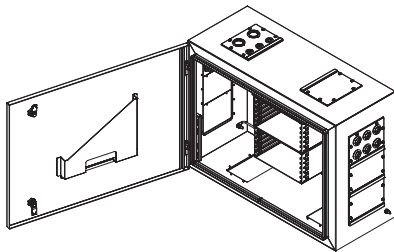
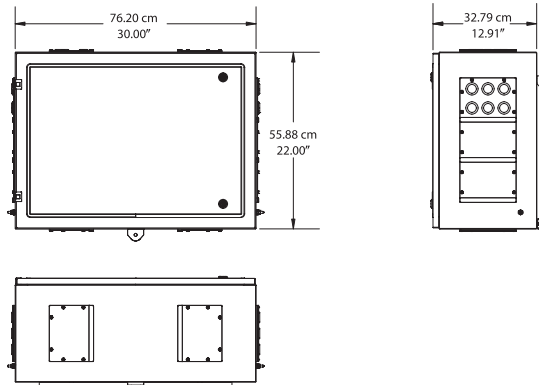

OEE 720/1440

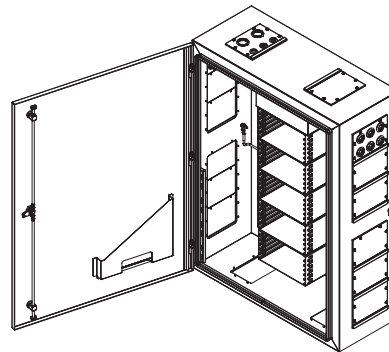
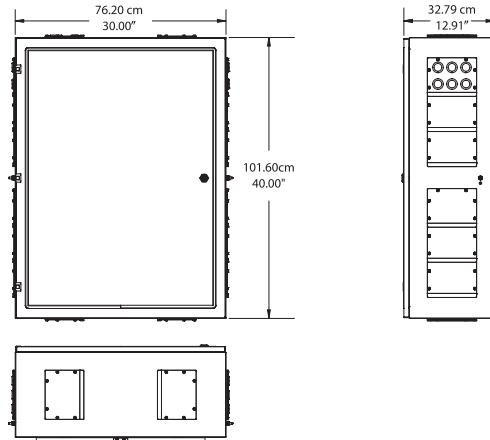

Qualifications

GOVERNING BODY	STANDARD CODE
NEMA	Type 3

continued
→

LightLink Optical Entrance Enclosures

Ordering Information

DESCRIPTION	MODEL NO.	AFL NO.
<p>OPTICAL ENTRANCE ENCLOSURE</p> <p>576 Single Fusion or 1728 Mass Fused Splice Capacity, up to 60 Cable Entry Ports</p> <p>Includes:</p> <ul style="list-style-type: none"> (2) 6-Port Standard Shingles (each port accepts a 0.472-0.7089" Cable) (1) 5-Port Shingles (2 Ports accept a 0.708-0.988" cable, and 3 small Ports accept a cable 0.236-0.473") (4) Medium Sealing and Retention Kits (each supporting a 0.472-0.708" cable) (1) Large Sealing and Retention Kit (each supporting a 0.708-0.988" cable) (3) Metallic Cable Bonding Kits (1) Wall-Mount Hardware (1) OEE Locking Key 	OEE-288/576	911309-00-05
<p>OPTICAL ENTRANCE ENCLOSURE</p> <p>576 Single Fusion or 1728 Mass Fused Splice Capacity, up to 60 Cable Entry Ports</p> <p>Includes:</p> <ul style="list-style-type: none"> (2) 6-Port Standard Shingles (each port accepts a 0.472-0.7089" Cable) (1) 5-Port Shingles (2 Ports accept a 0.708-0.988" cable, and 3 small Ports accept a cable 0.236-0.473") (4) Medium Sealing and Retention Kits (each supporting a 0.472-0.708" cable) (1) Large Sealing and Retention Kit (each supporting a 0.708-0.988" cable) (3) Metallic Cable Bonding Kits (1) Wall-Mount Hardware (1) OEE Locking Key (6) OEE Fiber Splice Tray 	OEE-288/576-6T	912371-00-00
<p>OPTICAL ENTRANCE ENCLOSURE</p> <p>1440 Single Fusion or 4320 Mass Fused Splice Capacity, up to 60 Cable Entry Ports</p> <p>Includes:</p> <ul style="list-style-type: none"> (2) 6-Port Standard Shingles (each port accepts a 0.472-0.7089" cable) (1) 5-Port Shingles (2 Ports accept a 0.708-0.988" cable, and 3 small Ports accept a cable 0.236-0.473") (4) Medium Sealing and Retention Kits (each supporting a 0.472-0.708" cable) (1) Large Sealing and Retention Kit (each supporting a 0.708-0.988" cable) (3) Metallic Cable Bonding Kits (1) Wall-Mount Hardware (1) OEE Locking Key 	OEE-720/1440	911275-00-05
<p>OPTICAL ENTRANCE ENCLOSURE</p> <p>1440 Single Fusion or 4320 Mass Fused Splice Capacity, up to 60 Cable Entry Ports</p> <p>Includes:</p> <ul style="list-style-type: none"> (2) 6-Port Standard Shingles (each port accepts a 0.472-0.7089" cable) (1) 5-Port Shingles (2 Ports accept a 0.708-0.988" cable, and 3 small Ports accept a cable 0.236-0.473") (4) Medium Sealing and Retention Kits (each supporting a 0.472-0.708" cable) (1) Large Sealing and Retention Kit (each supporting a 0.708-0.988" cable) (3) Metallic Cable Bonding Kits (1) Wall-Mount Hardware (1) OEE Locking Key (12) OEE Fiber Splice Tray 	OEE-7220/1440-12T	912372-00-00

continued
→

LightLink Optical Entrance Enclosures

Accessories

DESCRIPTION	MODEL NO.	AFL NO.
OEE Fiber Splice Tray	STF-48	911442-00-00
Metallic Cable Bonding Kit	MBK-1	911260-00-01
Work Shelf	OEE-WS	911262-00-00
Cable Retention and Sealing Kit – Small (Accepts 0.236-0.473" O.D. Cable)	CRSK236-473	911310-00-00
Cable Retention and Sealing Kit – Medium (Accepts 0.472-0.708" O.D. Cable, four included with OEE)	CRSK472-708	911310-01-00
Cable Retention and Sealing Kit – Large (Accepts 0.708-0.988" O.D. Cable, one included with OEE)	CRSK708-988	911310-02-00
Cable Retention and Sealing Kit – XLarge (Accepts 0.866-1.25" O.D. Cable)	CRSK866-1250	911310-03-00
Cable Retention and Sealing Kit – XXLarge (Accepts 1.25-1.49" O.D. Cable)	CRSK1250-1490	911310-04-00
Shingle Kit – Standard, 6-Ports (Accepts Six Cables From 0.472-0.708" O.D., two included with OEE)	SK-STD	911261-00-00
Shingle Kit – Standard, 5-Ports (2) Large (0.708-0.988" O.D. Cable Ports) (3) Small (0.236-0.472" O.D. Cable Ports) (One Included with OEE)	SK-LS	911261-01-00
Shingle Kit, Two X-Large, (2) Cable Ports (0.866-1.25" O.D.)	SK-XL	911261-02-00
Shingle Kit, Two XX-Large, (2) Cable Ports (1.25-1.49" O.D.)	SK-XXL	911261-03-00
Security Door Latch Key Only	—	18295-00-00
Key Locking Kit for OEE, 1 lock* *2 required for OEE-288/576 *1 required for OEE-720/1440	OEE-LK	911428-00-00
Ground Bar Kit for OEE: additional internal ground bar	OEE-GBK	911429-00-00

Cable Bonding Kit

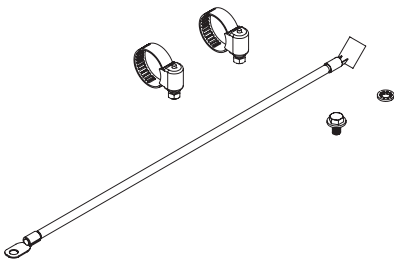

Cable Retention and Sealing Kit

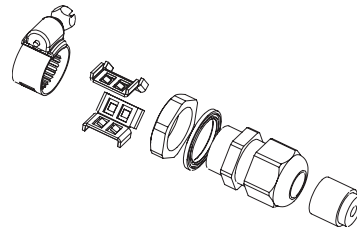

Work Shelf

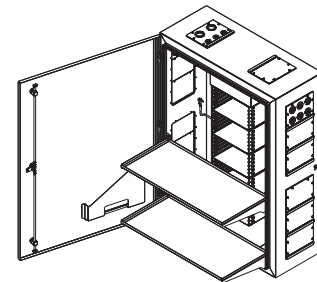



LL-5D Optical Splicing and Distribution Enclosure

The LL-5D Optical Splicing and Distribution Enclosure provides for organizing, splicing and interconnecting fibers in broadband FTTx, distribution and building entrance applications. The enclosure features a durable outdoor polymer-based material and a fully-gasketed hinged cover. The internal Apex® trays may be removed from the enclosure and brought to a splicing table to complete splicing, fiber routing and fiber management. The cable entry base allows for the installation of cable through a grommet or conduit system, and can be coupled to a fixed 12 inch stackable storage skirt. Multiple skirts can be stacked to achieve the desired length.

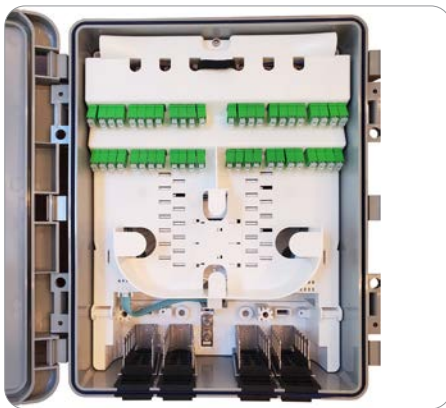

LL-5D Enclosure shown with Interconnect Tray and Grommets installed

Features

Enclosure

- Independent cable strain-relief for input and drop cables
- Unique self-sealing grommet system
- Self-contained inner chassis frame with separate outer housing
- Dual telco can-wrench locking fasteners
- Hinged cover securable with standard padlock
- Internal, owner-accessible security screw
- Available with a variety of connector types and cable entrance choices
- Pre-molded splice tray in the base of the enclosure

Apex Splice Tray Kit

- Available with (2) Factory Pre-installed AX-TRAY-2S-2 Universal Splice Trays with SC/APC or SC/UPC 900 μm pigtailed for up to 48 connections.
- Pigtailed are available in tight buffered or ribbon fiber
- Apex Trays may be purchased separately to upgrade existing splice-only units



LL-5D Conduit Base



LL-5D Grommet Base

Specifications

PARAMETER	VALUE
Material – Housing	Polycarbonate
Color	Gray
Size (H x W x D in.)	(H x W x D in.) 16" x 14.5" x 5.5" (total length 17.75" including mounting brackets)
Weight (lbs)	7.5
Adapters	Up to (48) SC
Splice	Connectorized: Up to (2) AX-TRAY-2S-2 up to 48 single fused fibers or 4 mass fusion sleeves
	Splice-only: Up to (2) AX-TRAY-2S-2 and (2) AX-TRAY-MOD for 144 single fused or 72 mass fusion splice sleeves

continued



LL-5D Optical Splicing and Distribution Enclosure

Ordering Information — LL-5D Enclosure

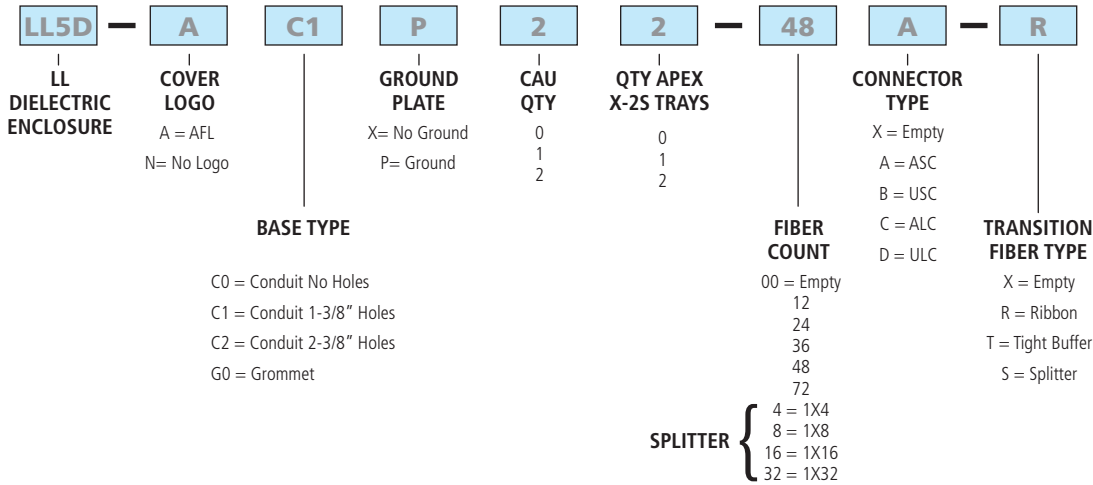

Ordering Information — Apex Splice Trays

DESCRIPTION	AFL NO.
X-2S Tray Fully Loaded with Two Splice Modules (288 fibers per tray only recommended for rollable ribbon, e.g. AFL SWR)	AX-TRAY-2S-2

Ordering Information — LL-5D Skirt Kit

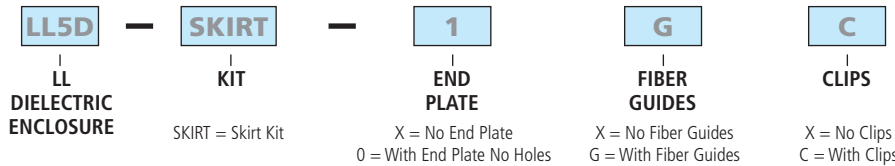

LL-5D Skirt



LL-5D Enclosure with Skirt

Qualifications

GOVERNING BODY	STANDARD CODE
NEMA	Type 3
Telcordia	GR-2898

Contact AFL for further details.

Apex® X-2S Splice Trays

Splice Trays and Splice Modules

Apex X-2S closures utilize X-2S size splice trays. Trays can be ordered fully loaded or half loaded with splice modules. For "rollable" type ribbon such as AFL's SpiderWeb Ribbon®, trays can be fully loaded for 24 mass splices, or 288 fibers per tray. For standard ribbon, AFL recommends half loaded for 6 mass splices single-stacked, or 72 fibers.

Ordering Information

DESCRIPTION	TRAY CAPACITY		AFL NO.
	SINGLE	MASS	
X-2S Tray Loaded with One Splice Module	18	72	AX-TRAY-2S-1
X-2S Tray Fully Loaded with Two Splice Modules (288 fibers per tray only recommended for rollable ribbon, e.g. AFL SWR)	36	288	AX-TRAY-2S-2
Additional splice module (18 single fusion triple stacked, 12 mass fusion double stacked, 6 mechanical) – Pack of 20	–	–	AX-TRAY-MOD-20
X-2S Tray Empty	–	–	AX-TRAY-2S-E

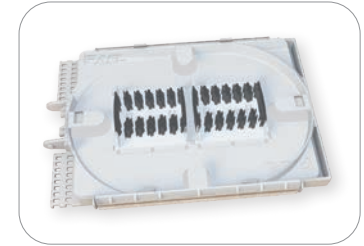

Dimensions

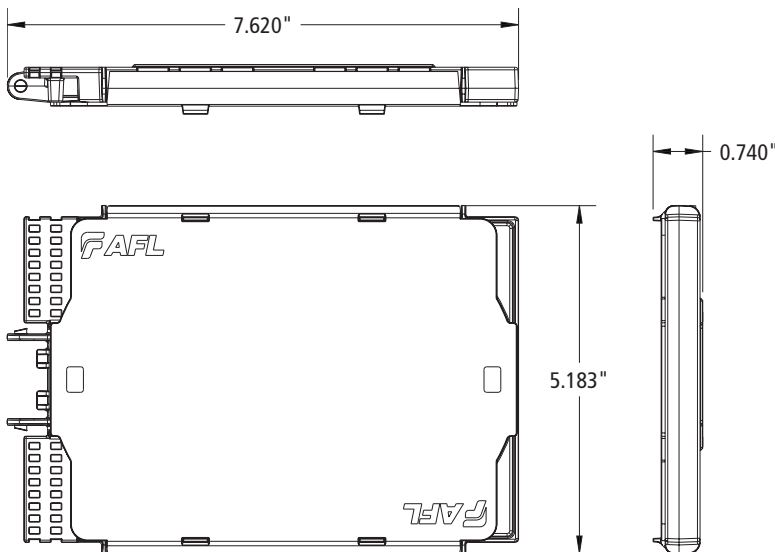



LightLink 580 Optical Splicing and Distribution Enclosure

The LightLink (LL) 580 Optical Splicing and Distribution Enclosure provides for organizing, splicing and interconnecting fibers in broadband, distribution and building entrance applications. The splice tray panel is equipped with LGX® 118 footprint snaps so various types of connectors may be installed. The enclosure features a scratch resistant powder coated base and a fully gasketed hinged cover. The cover was designed so that it may be installed on either side of the enclosure where there are space restrictions. The internal interconnect tray and back-plate may be removed from the enclosure and brought to a splicing table to complete splicing, fiber routing and fiber management. The cable entry base has four interchangeable configurations to allow the installation of cable through a grommet system, or through pre-installed conduit couplings.

Features

Enclosure

- Independent cable strain-relief for flat drop cable and 2 mm/3 mm drops
- Unique self-sealing grommet system
- Self-contained inner chassis frame with separate outer housing
- Dual telco can-wrench locking fasteners
- Hinged cover securable with standard padlock
- Internal, owner-accessible security screw
- Available with a variety of connector types and cable entrance choices

Interconnect Splice Tray Kit

- Included: (2) Factory Pre-installed LL-7644 Universal Splice Tray with SC-UPC 900 μm pigtails for up to 72 connections. LC-UPC Duplex adapters may be installed for up to 144 LC connections with mass fusion.
- Interconnect Tray may be purchased with either SC-UPC adapters and pigtails preinstalled or LC-UPC Duplex adapters and pigtails pre-installed.

Specifications

PARAMETER	VALUE
Material – Housing	16 Gauge Aluminum
Coating	Electrostatically applied powder paint
Color	Beige
Size (H x W x D in.)	27.5" x 13.0" x 5.625" (total length: 33.5" L x 13")
Weight (lbs)	15.2
Adapters	(72) SC or (72) LC Duplex
Splice	(2) LL-7644 up to 120 single fused fibers or 24 mass fusion sleeves (2) LL-4808 L-R up to 72 single fused fibers or 24 mass fusion sleeves

continued →

LightLink 580 Optical Splicing and Distribution Enclosure

Ordering Information

DESCRIPTION	AFL NO.
LL-580 Enclosure Base (No Bottom Plate or LGX® Tray)	FM002814
Interconnect Trays	
Kit, Splice/4x LGX® Interconnect Tray, with (2) LL-7644 Trays	FM002858-001
Kit, Splice/4x LGX® Interconnect Tray, 24 SCU, with (2) LL-7644 Trays	FM002858-SCU
Kit, Splice/4x LGX® Interconnect Tray, 24 SCA, with (2) LL-7644 Trays	FM002858-SCA
Kit, Splice/4x LGX® Interconnect Tray, 24 LCU, with (2) LL-7644 Trays	FM002858-LCU
Splice Trays	
LL-7644 Splice Tray used with LGX® Interconnect Tray	FA000044
LL-4808 L-R Splice Tray used with LGX® Interconnect Tray	FA000037
Plate Kits	
Plate Kit (2 – 2 in. NPT and 2 – 1 in. KO)	FM002653
Plate Kit (2 – Single Cable Grommets [L&R] and 2 – Multiport Grommets [Center])	FM001937
Plate Kit (2 – Single Cable Grommets [L&R])	FM003014
Plate Kit (1 – 2 in. NPT and 4 – 1 in. NPT)	FM001959
Plate Kit (3 – KO)	FM003023
Grommet and NPT Kits	
1 in. NPT Kit (2 – 1 in NPT Fittings and cable hardware to be used with FM002653)	FM003015
2 in. NPT Kit (2 – 2 in NPT Fittings and cable hardware to be used with FM003023)	FM003016
Dual Cable Grommet Kit (2/kit)	911386-00-01
Accessories	
Conduit Skirt	FM002895
Pre-configured Base Enclosures and Interconnect Tray	
LL-580, 24F SC/UPC Interconnect Kit, 24F SC/UPC Pigtail Kit, (2) LL-7644 Splice Trays, No Bottom Plate	FM003248
LL-580, 48F SC/UPC Interconnect Kit, 48F SC/UPC Pigtail Kit, (2) LL-7644 Splice Trays, No Bottom Plate	FM003249
LL-580, 72F SC/UPC Interconnect Kit, 72F SC/UPC Pigtail Kit, (2) LL-7644 Splice Trays, No Bottom Plate	FM003250
LL-580, Interconnect Kit, No Adapter Plates, No Pigtail Kit, (2) LL-7644 Splice Trays, No Bottom Plate	FM003251

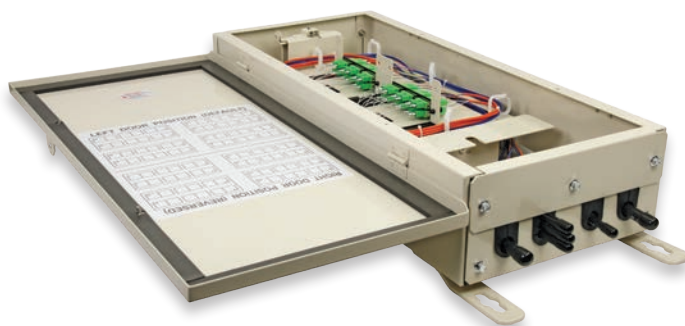

LL-580 Enclosure shown with the Cable Grommet Bottom Plate installed

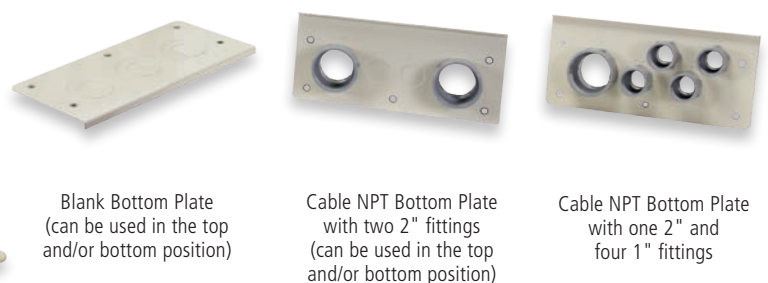

Blank Bottom Plate
(can be used in the top and/or bottom position)

Cable NPT Bottom Plate with two 2" fittings
(can be used in the top and/or bottom position)

Cable NPT Bottom Plate with one 2" and four 1" fittings

Qualifications

GOVERNING BODY	STANDARD CODE
NEMA	Type 3
Telcordia	GR-2898

Contact AFL for further details.



LightLink 550 Optical Splicing and Distribution Enclosure

The LightLink (LL) 550 Optical Splicing and Distribution Enclosure provides for organizing, splicing and interconnecting fibers in broadband, distribution and building entrance applications. The splice tray panel is equipped with LGX® 118 footprint snaps so various types of connectors may be installed. The enclosure features a scratch resistant powder coated base and a fully gasketed hinged cover. The internal interconnect tray and back-plate may be removed from the enclosure and brought to a splicing table to complete splicing, fiber routing and fiber management. The cable entry base allows for the installation of cable through a grommet system, and can be coupled to either a fixed 12 inch slack storage skirt or a telescoping 24 to 36 inch skirt.

Features

Enclosure

- Independent cable strain-relief for flat drop cable and 2 mm / 3 mm drops
- Unique self-sealing grommet system
- Self-contained inner chassis frame with separate outer housing
- Dual telco can-wrench locking fasteners
- Hinged cover securable with standard padlock
- Internal, owner-accessible security screw
- Available with a variety of connector types and cable entrance choices

Interconnect Splice Tray Kit

- Available with (2) Factory Pre-installed LL-4808 Universal Splice Trays with SC/APC or SC/UPC 900 µm pigtailed for up to 48 connections.
- Interconnect Tray may be purchased separately to upgrade existing splice-only units to accept LGX-118 adapter plates.

Specifications

PARAMETER	VALUE
Material – Housing	16 Gauge Aluminum
Coating	Electrostatically applied powder paint
Color	Beige
Size (H x W x D in.)	(H x W x D in.) 18" x 9" x 5.25" (total length 22" including mounting brackets)
Weight (lbs)	7.5
Adapters	Up to (48) SC
Splice	Connectorized: Up to (2) LL-4808 L-R up to 72 single fused fibers or 24 mass fusion sleeves
	Splice-only: Up to (4) LL-4808 L-R up to 144 single fused fibers or 48 mass fusion sleeves

continued
→

LightLink 550 Optical Splicing and Distribution Enclosure

Ordering Information

DESCRIPTION	AFL NO.
Base Enclosures and Interconnect Tray	
LL-550, 24F SC/APC Interconnect Kit, 24F SC/APC Pigtail Kit, (2) LL-4808 Splice Trays, 4 Grommet Bottom Plate	FM004181
LL-550, 48F SC/APC Interconnect Kit, 48F SC/APC Pigtail Kit, (2) LL-4808 Splice Trays, 4 Grommet Bottom Plate	FM004182
LL-550, Splice-only Security Cover, (2) LL-4808 Splice Trays, 4 Grommet Bottom Plate	FM004183
LL-550, 24F SC/UPC Interconnect Kit, 24F SC/UPC Pigtail Kit, (2) LL-4808 Splice Trays, 4 Grommet Bottom Plate	FM004214
LL-550, 48F SC/UPC Interconnect Kit, 48F SC/UPC Pigtail Kit, (2) LL-4808 Splice Trays, 4 Grommet Bottom Plate	FM004215
LL-550 LGX-118 Interconnect Tray (for upgrading splice-only to accept LGX-118 adapter plates)	FM004216
Splice Trays	
LL-4808 L-R Splice Tray used with LGX® Interconnect Tray	FA000037
Grommet and NPT Kits	
1 in. NPT Kit (2 – 1 in NPT Fittings and cable hardware to be used with FM004177)	FM003015
2 in. NPT Kit (2 – 2 in NPT Fittings and cable hardware to be used with FM004177)	FM003016
Dual Cable Grommet Kit (2/kit)	911386-00-01
Accessories	
Fixed Conduit Skirt	FM004177
Telescoping Skirt	FM004072



LL-550 Fixed Skirt

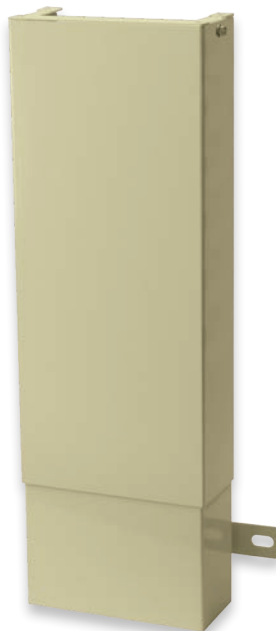

LL-550 Telescoping Skirt

Qualifications

GOVERNING BODY	STANDARD CODE
NEMA	Type 3
Telcordia	GR-2898

Contact AFL for further details.

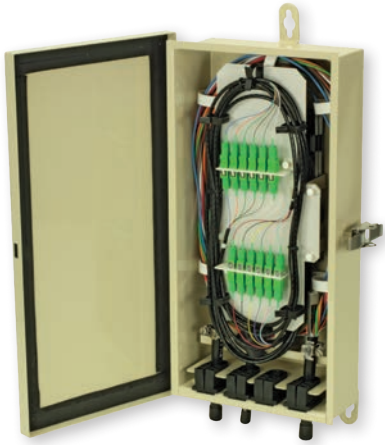

LL-500 with interconnect kit installed



LL-500 with LL-2450 splice tray installed

LightLink 500 Optical Splicing and Distribution Enclosure

The LightLink (LL) 500 Optic Splicing and Distribution Enclosure provides for organizing, splicing and interconnecting fibers in broadband, distribution and building entrance applications. The enclosure features a scratch and corrosion resistant powder paint coating base and a fully gasketed hinged cover. A unique self-sizing grommet design allows for express and pre-terminated cable installation. The LL-500 supports up to five LL-2450 splice trays for up to 60 single fusion splices or three LL-4850 splice trays (not included in base unit) and an optional 12 fiber, hinged Interconnect Module.

Features

- Independent cable strain relief system
- Cable entry/exit grommet seals
- Fiber routing system
- Splice tray support system
- Hinged cover
- Supports optional Interconnect Modules
- Interconnect Module supports up to 12 SC bulkhead adapters
- Secured with a standard padlock
- 4 cable ports with standard grommets
- 8 cable ports with optional expansion kits

Specifications

PARAMETER	VALUE
Material	Steel
Coatings	Electrostatically applied, powder coat
Color	Antique white
Cable Ports	4-8
Cable Sizes (Max. O.D. – Min. O.D.)	4 @ 0.3-0.77" Up to 8 with Dual Grommet Kits 4 @ 0.3-0.65" 4 @ 0.3-0.5"
Dimensions (H x W x D) in. (cm)	17.5 x 9.0 x 4.0 (44.45 x 22.86 x 10.16)
Weight lbs. (kg)	6.5 (2.95)

Ordering Information

DESCRIPTION	AFL NO.
LL-500-U-0	FM000326
LL-500 Interconnect Kit with SC UPC adapters	FM000385
LL-500 Interconnect Kit with SC APC adapters	FM000407
LL-500 Interconnect Kit without adapters	FM000408
LL-500 with Multi-port Grommets	FM000659
LL-2450 Single Fusion Splice Tray (stores 12 single fusion splices)	91957-00
LL-4850 Mass Fusion Splice Tray (stores 8 mass fusion sleeves - 96 fibers)	91958-00
LL-500 Multi-port Grommet Kit, 6 drop cable entry up to 0.37" OD	FC000573

Qualifications

GOVERNING BODY	STANDARD CODE
NEMA	Type 3

Contact AFL for further details.



LL-400sx



LL-400sx in 1010 pedestal

LightLink 400sx Optical Splicing and Distribution Enclosure

The LightLink (LL) 400sx Fiber Optic Splicing and Distribution Enclosure provides for organizing, splicing, and interconnecting fibers in FTTx, broadband, distribution and building entrance applications. Each LL-400sx enclosure features a scratch resistant powder coated aluminum base and a fully gasketed cover. A unique self-sizing grommet design allows for express and preterminated cable installation. The LL-400sx is a butt-style enclosure equipped with four independent cable entry/exit grommets, used for outdoor pedestal or indoor building entrance and riser splicing applications. The unit supports a maximum storage and splicing capacity of up to 192 single or 576 mass-fused fibers. The LL-400sx can also mount up to two LGX118® adapter plates (splicing capacity limited to 144 single fusion and 432 mass fusion splices when adapter plates are installed).

Features

- Independent cable strain relief system
- Cable entry/exit grommet seals
- Removable Hinged Front Cover
- Fiber routing system
- Splice tray support system
- 192 single fusion splices
- 576 mass fusion splices
- Grounding hardware kit included

Applications

- OSP Splicing
- MDU Splicing
- FTTx Distribution

Specifications

PARAMETER	VALUE
Material	Chassis – aluminum
Coatings	Electrostatically applied, powder coat
Color	Antique white
Dimensions (H x W x D) in. (cm)	23.9 x 9.5 x 5.0 (58.4 x 24.13 x 12.7)
Weight lbs (kg)	5.0 (2.3)

Ordering Information

DESCRIPTION	AFL NO.
LL-400sx	EA000370
LL-4848 Mass Fusion Splice Tray	911437-00-02
LL-2448 Universal Splice Tray	911289-00-02
LL-2448-48S Single Fusion Splice Tray	FA000045
LL-2400 Single Fusion Splice Tray	91710-06
Channel MAH1010 Pedestal	FM000776
Channel MAH1212 Pedestal	FM000655
IDEAA® Module LGX Mount Bracket	EA000061
IDEAA Pigtail Kit	EA000166
IDEAA SC/APC 1x32 Splitter Module	EA000102
IDEAA SC/APC 1x16 Splitter Module	EA000103
IDEAA SC/APC 1x8 Splitter Module	EA000104
IDEAA SC/APC 1x4 Splitter Module	EA000105



LL-400b shown with optional interconnect module



Hardware kit for external grounding (included)

LightLink 400b Optical Splicing and Distribution Enclosure

The LightLink (LL) 400b Fiber Optic Splicing and Distribution Enclosure provides for organizing, splicing and interconnecting fibers in FTTx, broadband, distribution and building entrance applications. Each LL-400b enclosure features a scratch resistant powder coated aluminum base and a fully gasketed cover. A unique self-sizing grommet design allows for express and preterminated cable installation. The LL-400b is a butt-style enclosure equipped with 6 independent cable entry/exit grommets, used for outdoor pedestal or indoor building entrance and riser splicing applications. The unit supports a maximum storage and splicing capacity of up to 240 single or 432 mass-fused fibers.

When installed into an LL-400b, the Inteconnect Module supports connectivity when used with LGX-118 adapter plates (purchased separately). It is used in outdoor pedestals or building mounted LL-400b enclosures where interconnection is required.

Features

- Independent cable strain relief system
- Cable entry/exit grommet seals
- Fiber routing system
- Splice tray support system
- Supports optional interconnect modules
- 240 single fusion splices
- 432 mass fusion splices
- Grounding hardware kit included

Applications

- OSP Splicing
- MDU Splicing
- FTTx Distribution

Specifications

PARAMETER	VALUE
Material	Chassis – aluminum
Coatings	Electrostatically applied, powder coat
Color	Antique white
Dimensions (H x W x D) in. (cm)	22.75 x 11.00 x 4.0 (57.79 x 27.94 x 10.16)
Weight lbs (kg)	6.5 (2.95)

Ordering Information

DESCRIPTION	AFL NO.
LL-400b	91894-04
LL-400b In 1212 Pedestal	FM000636
LL-410 Interconnect Module, Supports Up To 2 LGX-118 Adapter Plates	911410-00-04
LL-2448 Universal Splice Tray	911289-00-02
LL-2448-48S Single Fusion Splice Tray	FA000045
LL-2400 Single Fusion Splice Tray	91710-06
LL-400 Security Kit	FM000787
LL-400b Large Dual-port Grommet Kit	911406-00-00
LL-400b Large Multi-port Grommet Kit	FC000352
LG-410/LG-500 Dual-port Grommet Kit	911386-00-01
LG410/LG500 Multi-port Grommet Kit	FC000573

LightLink 24 Slim-Line Pedestal

The LightLink (LL) 24 Pedestal provides an easily accessible solution for splicing underground fiber cable, branches and drops. The pedestal may be buried up to the burying guide lines located on the pedestal base.

With the capability to hold up to three Apex™ X-2 Splice Trays, the LL-24 pedestal is capable of up to 216 single fusion, 432 mass fusion with standard ribbon, or 864 mass fusion with “rollable ribbon” fiber types such as AFL’s SpiderWeb Ribbon® (SWR®). One side of the pedestal may be used for splicing optical fibers while the opposite side may be used for copper splicing of branch or drop cables.



Features

- Easily installed in traditional buried pedestal applications
- All cable routing, retention, mounting and grounding accessories included
- Holds up to three (3) Apex X-2 splice trays
- Fiber routing rings allow for easy storage and maintenance of the buffer tubes and using tie-wraps, copper pairs may be secured to the mounting plate
- Defer deployment cost – open buffer tubes when access to fibers is required
- Standard 216-tool or similar tool required to remove the dome

Applications

- FTtx Networks
- Local Area Networks

Specifications

PARAMETER	VALUE
Height to Ground Line, in (cm)	30.2 (77.5)
Total Height, in (cm)	40.2 (102.1)
Inner Diameter, in (cm)	7.8 x 6.0 (19.7 x 15.2) Oval
Splice Capacity – Single, Mass (SWR), Mass (Standard)	216, 864, 432
Splice Tray Capacity	3

Ordering Information

DESCRIPTION	AFL NO.
LL-24 Pedestal, Empty	FE000325

continued
→

LightLink 24 Slim-Line Pedestal

Splice Trays and Splice Modules

The LL-24 Pedestal utilizes X-2 size splice trays. Trays can be ordered fully loaded or half loaded with splice modules. For “rollable” type ribbon such as AFL’s SpiderWeb Ribbon, trays can be fully loaded for 24 mass splices or 288 fibers per tray. For standard ribbon, AFL recommends half loaded for 12 mass splices single-stacked, or 144 fibers.

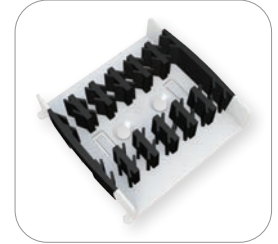
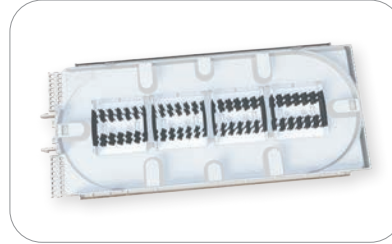

Ordering Information

DESCRIPTION	TRAY CAPACITY		AFL NO.
	SINGLE	MASS	
X-2 Tray Loaded with Two Splice Modules	36	144	AX-TRAY-2-2
X-2 Tray Fully Loaded with Four Splice Modules	72	288	AX-TRAY-2-4
Additional splice module (18 single fusion triple stacked, 12 mass fusion double stacked, 6 mechanical) – Pack of 20	—	—	AX-TRAY-MOD-20
X-2 Tray Empty	—	—	AX-TRAY-2-E

Dimensions

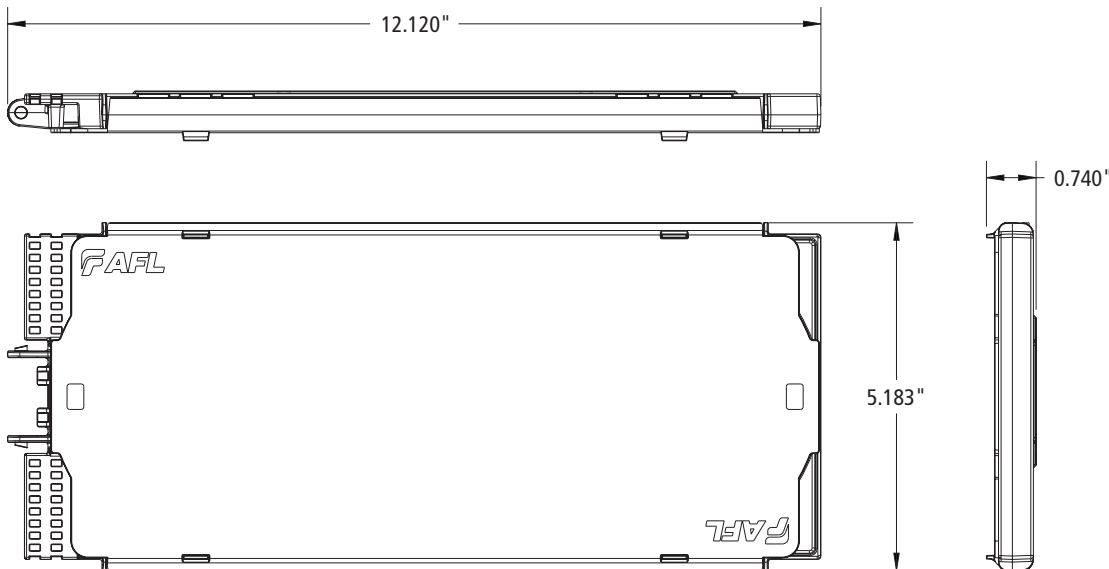

continued
→

LightLink 24 Slim-Line Pedestal

Splitter Splice Trays

Passive optical splitters, or PLCs (Planar Lightwave Circuits), can be provided preinstalled into the Apex X-2 splice tray. PLCs can either be installed and splice within the same tray, or provided with a separate dedicated tray for splicing, with fibers routed between trays using protective tubing. A third option provides one additional tray to separate input and output fiber splicing.

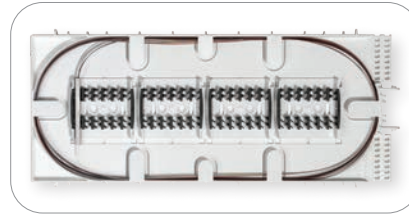

Ordering Information

DESCRIPTION	SPLIT RATIO	AFL NO.
X-2 Tray with Four Splice Modules, (1) 1x2 PLC Splitter	1x2	AX-TRAY-2-12-1
X-2 Tray with Four Splice Modules, (1) 1x4 PLC Splitter	1x4	AX-TRAY-2-14-1
X-2 Tray with Four Splice Modules, (1) 1x8 PLC Splitter	1x8	AX-TRAY-2-18-1
X-2 Tray with Four Splice Modules, (1) 1x16 PLC Splitter	1x16	AX-TRAY-2-116-1
X-2 Tray with Four Splice Modules, (1) 1x32 PLC Splitter	1x32	AX-TRAY-2-132-1
X-2 Tray with (1) 1x2 PLC Splitter and Separate Splicing Tray with Four Splice Modules	1x2	AX-TRAY-2-12-2
X-2 Tray with (1) 1x4 PLC Splitter and Separate Splicing Tray with Four Splice Modules	1x4	AX-TRAY-2-14-2
X-2 Tray with (1) 1x8 PLC Splitter and Separate Splicing Tray with Four Splice Modules	1x8	AX-TRAY-2-18-2
X-2 Tray with (1) 1x16 PLC Splitter and Separate Splicing Tray with Four Splice Modules	1x16	AX-TRAY-2-116-2
X-2 Tray with (1) 1x32 PLC Splitter and Separate Splicing Tray with Four Splice Modules	1x32	AX-TRAY-2-132-2
X-2 Tray with (1) 1x2 PLC Splitter and 2 Separate Splicing Trays with Four Splice Modules each	1x2	AX-TRAY-2-12-3
X-2 Tray with (1) 1x4 PLC Splitter and 2 Separate Splicing Trays with Four Splice Modules each	1x4	AX-TRAY-2-14-3
X-2 Tray with (1) 1x8 PLC Splitter and 2 Separate Splicing Trays with Four Splice Modules each	1x8	AX-TRAY-2-18-3
X-2 Tray with (1) 1x16 PLC Splitter and 2 Separate Splicing Trays with Four Splice Modules each	1x16	AX-TRAY-2-116-3
X-2 Tray with (1) 1x32 PLC Splitter and 2 Separate Splicing Trays with Four Splice Modules each	1x32	AX-TRAY-2-132-3



24 Port ST Loaded Mini DIN Enclosure



12 Port SC Loaded Mini DIN Enclosure



FDE-24LC1-P
24F LC Mini DIN enclosure for patching

Mini DIN Rail Mounted Enclosure

The Mini DIN Rail Mounted Enclosure's compact design gives it the ideal form factor for installation into densely populated industrial cabinets.

Features and Benefits

- Small size making it very versatile
- Accommodates up to 12 or 24 x SC, ST or LC duplex adapters
- Ideal for housing pre-terminated loose tube and tight buffered cables
- Top and bottom cable entry to suit installation environment

Applications

- Process automation and control
- Intelligent transport system
- Rail signalling and control networks
- Power systems and control
- MTP pre-terminated cabling solutions

Technical Specifications

DESCRIPTION	12 PORT MINI DIN RAIL ENCLOSURE	24 PORT (PATCH ONLY) MINI DIN RAIL ENCLOSURE
Dimensions W x H x D (mm)	54.5 x 155 x 113	109 x 155 x 113
Weight (lbs)	1.5	3.0
Maximum Number of Splices	12	N/A
Maximum Fiber Count (Front Panel)	12 SC, ST and LC 24	SC, ST
Incoming Cable Ports	1 top and bottom	2 top and bottom (includes internal routing hole for single cable 24 fiber installation)
Material and Color	Powder coated Mercury Grey	
Standard Accessories	Cable gland, central strain relief post, DIN rail mounting clip, laser badge, fiber clips and through adapters	

Ordering Information

FDE	—	12	SC	1	—	S
Fiber DIN Enclosure		Fiber Count	Adapter Type	Fiber Type		Enclosure Function
		06 ¹	SC	1 – 9/125 μm		S ³ – Splicing
		12	SCA ⁵ (SM only)	SM OS1		M ^{2,4} – MTP pre-terminated enclosure
		24 ²	LC	3 – 50/125 μm		P – Patching pre-terminated or direct terminated cables only
			LCA ⁵ (SM only)	MM OM3		
			ST	4 – 50/125 μm		
				MM OM4		
				6 – 62.5/125 μm		
				MM OM1		

Notes

1. Uses 12 port plates, empty ports are filled with blanking plugs
2. 24 fiber option for patch (P) and MTP pre-terminated (M) enclosures only
3. Splicing enclosures include splice tray, protectors and pigtailed for 06 and 12 fiber configurations
4. LC OM3, OM4 and OS1/2 only
5. SCA and LCA options stand for APC adapter types.

Accessories

Contact AFL for ordering information on additional accessories to be used with the FDE product line such as pigtailed, splicing consumables, termination consumables, and pre-tailed fiber optic cable assemblies.



Shown with four SC/APC adapters, security cover and grounding



"U-Grommet" Entry Option



1/2" Hole Entry Option

OptiNID® Duo Optical Demarcation Enclosure

AFL's OptiNID (OPN) Duo Optical Demarcation Enclosure is the latest entry in the OptiNID fiber optic demarcation family of products. The ultra-compact OPN Duo is designed with flexibility in mind with the capability to house up to 4 SC simplex or LC duplex adapters, along with the ability to house up to 18 single fiber or 6 mass fusion splices. The OPN Duo is also optimized for the use of AFL's FASTConnect® or FUSEConnect® field-installable connectors. The base of the enclosure houses an insert which incorporates fiber routing, splice tray, adapter plate, and cable retention features. The OPN Duo also has several optional features such as a clear splice/security cover for protecting provider-side connectors or a grounding plate for grounding armored or toneable drop cables. The OPN Duo is available with two different base cable entry options, either a pair of U-shaped "drop-in" style grommets, or two half-inch ports allowing for a variety of different entry accessories.

Features

- Integrated splice tray for up to 18 single fusion splices or 6 mass fusion
- Optional clear splice/security cover covers splices, pigtails and provider-side connectors
- Snap lock cover with optional 3/8" screw for added security
- "U-Grommets" provide easy drop-in cable entry or two half-inch ports for a variety of cable entry options
- Integrated mounting points external to the enclosure allow mounting to walls or poles without drilling holes through the box, creating leak paths

Applications

- FTTx – Fiber-to-the-Home (single family, multi-dwelling), Fiber-to-the-Business (multi-tenant)
- Wireless – Macro and small cell

Specifications

PARAMETER	VALUES
Dimensions – H x W x D	9.6 x 7.0 x 2.7 inches (24.4 x 17.7 x 6.8 cm)
Material	UL® listed flame retardant thermoplastic alloy
UV Resistance (Days Exposed)	60 per ASTM-G26-84
Flammability	UL94-5VA
Impact Test	-40°F (-40°C), 10 ft-lbs. on all external surfaces
Chemical Resistance 30 Days at 100°F and 95% RH	Resists chipping and/or cracking when subject to house paint, wasp spray, sulfuric acid, kerosene and sodium hydroxide
Drop Test	-40°F (-40°C), 3 ft. onto concrete surface 4 times
Rain	24 hours at 10 psi
Temperature Cycling with Humidity	30 day cycling from -40°F to 149°F (-40°C to 65°C) with 95% RH

continued
→

OptiNID® Duo Optical Demarcation Enclosure

Ordering Information

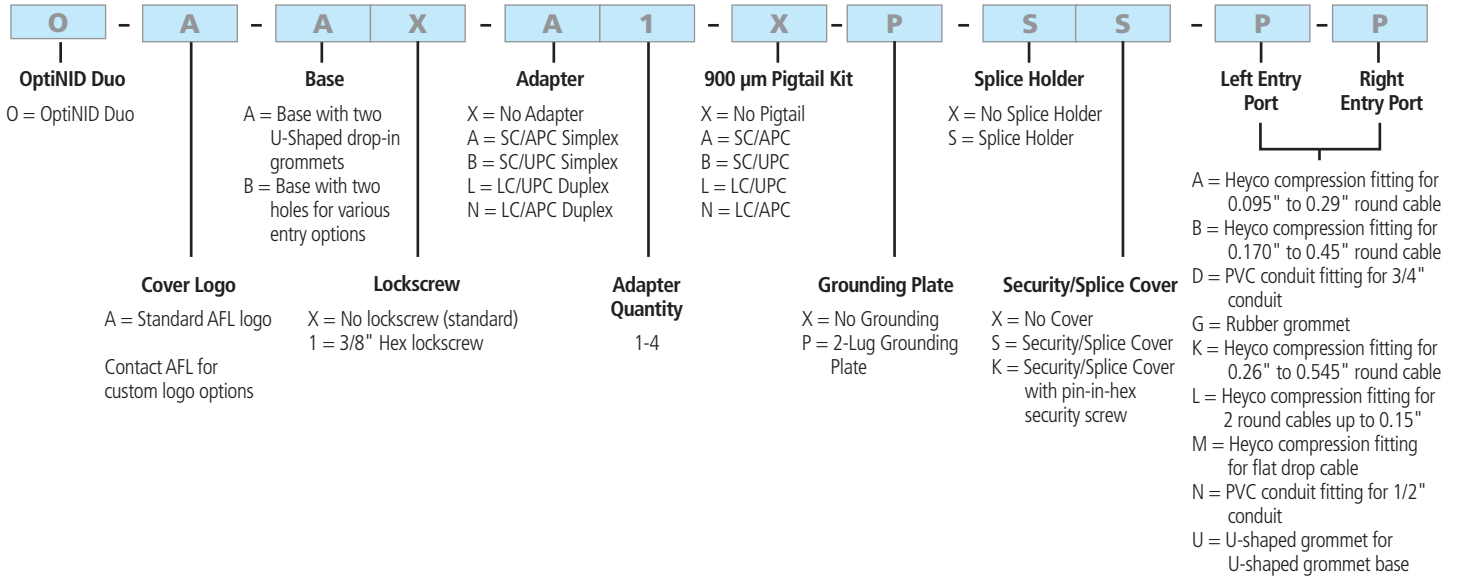

Ordering Information – Accessories

DESCRIPTION	AFL NO.
OptiNID Duo Splice Module, Pack of 20	AX-TRAY-MOD-20

NOTE: Options A-N available with the two-hole entry option only

Dimensions (in inches)

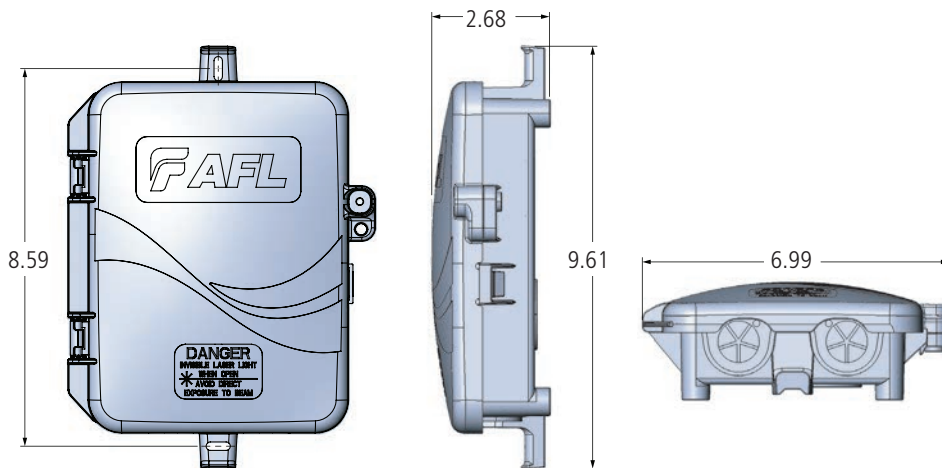

Qualifications

GOVERNING BODY	STANDARD CODE
Telcordia	GR-49, GR-2898

Contact AFL for further details.



OptiNID® 300 Series Optical Demarcation Slack Storage Closure

The OptiNID (OPN) 300 series are optical demarcation closures designed for use in either indoor or outdoor environments. Smaller to suit FTTH demarcation applications, the OPN-327SS and the OPN-350SS are equipped to handle up to two adapters each. Configured with routing rings positioned to accommodate safe slack storage, the OPN-300 series closures can be either wall or pole-mounted for ease of use and accessibility.

Features

- Weather-resistant thermoplastic alloy
- Self-latching, hinged cover design allows easy access without loose parts
- Routing rings positioned for safe slack storage
- Capacity for up to two adapters
- Ground stud provided in the OPN-350SS



OPN-327SS



OPN-350SS

Specifications

PARAMETER	VALUES
Dielectric Strength	Minimum 2500 Vrms for 1 minute
Impact Test	-40°F (-40°C), 5 ft-lbs on all external surfaces
Drop Test	-40°F (-40°C), 5 ft onto concrete surface four times
Rain	24 hours at 10 psi
UV Resistance (Days Exposed)	60 per ASTM-G26-84
Salt Fog (Days Exposed)	60 per ASTM-BLL7-90
Flammability	UL94-5V
Chemical Resistance 30 Days at 100°F and 95% RH	Resists chipping and/or cracking when subject to house paint, wasp spray, sulfuric acid, kerosene and sodium hydroxide
Material	UL® listed flame retardant thermoplastic alloy
Dimensions (H x W x D) in. (cm)	6.3 x 7.8 x 2.0 (15.7 x 19.7 x 5.0)
Cable Entrance in. (cm) diameter - Input	1 x 3/4" NPT (1.130"), 2 x 1/2" NPT (0.875")
Covers	Standard, molded-in snap finger and "F" termination
Operating Temperature Range – °F (°C)	-40 to 140 (-40 to 60)

Ordering Information

DESCRIPTION	AFL NO.
BASE PRODUCT ^{1,2}	
OptiNID OPN-327SS Slack Storage Box, 1 x SC/APC Adapter	DM000720
OptiNID OPN-350SS Slack Storage Box, 1 x SC/APC Adapter, Splice Chip, Ground Stud	DM000795
ACCESSORIES ³	
Heyco M3234 Compression Fitting, 18 mm to 11 mm Grip (includes 4) – Left Port Only	DM001171

Notes:

1. All standard OPN-300 Series configurations come equipped with a 3/4" NPT fitting, rubber grommet and Heyco M4519 compression fitting.
2. Contact AFL customer service for additional configurations.
3. See OptiNID Accessory Page for additional kits.



OptiNID® 500 Optical Demarcation Closure

The OptiNID (OPN) 500 is an optical demarcation closure designed for use in either indoor or outdoor environments. Small form factor for FTTH demarcation applications, the closure is capable of housing up to six bulkhead adapters in one 118 LGX® compatible adapter plate, and is equipped with an integrated splice tray, which holds up to six single fusion splices. The OPN-500 can be either wall or pole-mounted.

Features

- Weather-resistant thermoplastic alloy
- Self-latching, hinged cover design allows easy access without loose parts
- Capacity for one 118 LGX compatible adapter plate
- Provider override for customer lock
- 3/4" NPT conduit fitting, compression cable fittings or grommets entry ports

Specifications

PARAMETER	VALUES
Dielectric Strength	Minimum 2500 Vrms for 1 minute
Impact Test	-40°F (-40°C), 5 ft.-lbs on all external surfaces
Drop Test	-40°F (-40°C), 5 ft onto concrete surface four times
Rain	24 hours at 10 psi
UV Resistance (Days Exposed)	60 per ASTM-G26-84
Salt Fog (Days Exposed)	60 per ASTM-BLL7-90
Flammability	UL94-5V
Chemical Resistance 30 Days at 100°F and 95% RH	Resists chipping and/or cracking when subject to house paint, wasp spray, sulfuric acid, kerosene and sodium hydroxide
Material	UL® listed flame retardant thermoplastic alloy
Dimensions (H x W x D) in. (cm)	6.3 x 7.8 x 2.0 (15.7 x 19.7 x 5.0)
Cable Entrance in. (cm) diameter - Input	1 x 3/4" NPT (1.130"), 2 x 1/2" NPT (0.875")
Covers	Standard, molded-in snap finger and "F" termination
Operating Temperature Range – °F (°C)	-40 to 140 (-40 to 60)

Ordering Information

DESCRIPTION	AFL NO.
BASE PRODUCT ^{1,2}	
OptiNID OPN-500, No Adapters	DM001021
OptiNID OPN-500, 1 x SC/UPC Adapter	DM000550
OptiNID OPN-500, 1 x SC/APC Adapter	DM000766
OptiNID OPN-500, 6 x SC/UPC Adapters	DM000871
OptiNID OPN-500, 6 x SC/UPC Adapters, 6 x 1 m 900 µm Pigtailed	DM001109
ACCESSORIES ³	
Heyco M3234 Compression Fitting, 18 mm to 11 mm Grip (includes 4) – Left Port Only	DM001171
Kit, Six-Position Splice Chip, (includes 10)	DM000870

Notes:

1. All standard OPN-500 configurations come equipped with a 3/4" NPT fitting, rubber grommet and Heyco 3231 compression fitting, along with a splice chip for six single fusion splices.
2. Contact AFL customer service for additional configurations.
3. See OptiNID Accessory Page for additional kits.

LGX is a registered trademark of Furukawa Electric North America, Inc.

OptiNID® 760XL Optical Demarcation Closure

The OptiNID (OPN) 760XL is an optical demarcation closure designed for use in either indoor or outdoor environments. It is capable of housing up to 24 bulkhead adapters in two 118 LGX® compatible adapter plates and is equipped with a splice tray (LL-2425), which holds up to 32 single fusion splices. The OPN-760XL can be either wall or pole-mounted.

Features

- Capacity for up to two 118 LGX compatible adapter plates
- Rugged weather-resistant thermoplastic alloy
- Self-latching, hinged cover design allows easy access without loose parts
- Slip-in grommets allow pre-connectorized cable deployment
- Provider override is provided so that technician can override customer lock
- Security cover option available

Specifications

PARAMETER	VALUES
Dielectric Strength	Minimum 2500 Vrms for 1 minute
High Temperature Storage/Mold Stress	14 days at 159°F (70.55 °C)
Temperature Cycling with Humidity	150 day cycling from 40-140°F (4.44-60°C) with 95% RH
Impact Test	-40°F (-40°C), 5*/lbs on all external surfaces
Drop Test	-40°F (-40°C), 5* (12.7 cm) onto concrete surface 4 times
Rain	24 hours at 10 psi
UV Resistance (Days Exposed)	60 per ASTM-G26-84
Salt Fog (Days Exposed)	60 per ASTM-BLL7-90
Flammability	UL94-5V
Chemical Resistance 30 Days at 100 °F and 95% RH Subject to:	Resists chipping and/or cracking when subject to: house paint, wasp spray, sulfuric acid, kerosene and sodium hydroxide
Material	UL® listed flame retardant thermoplastic alloy
Dimensions (H x W x D) in. (cm)	13 x 13 x 3.75 (32.5 x 32.5 x 9.5)
Cable Entrances in. (cm) diameter—Input	4 x 0.875 (2.2)—3/4" conduit
Covers	Standard – molded-in snap finger and 3/8" hex head fastener



OPN-760XL with optional security cover kit



OPN-760XL with 3/4" Pipe Fitting Transition Kit



3/4" Pipe Fitting Transition Kit

Ordering Information

DESCRIPTION	AFL NO.
BASE PRODUCT ^{1,2}	
OptiNID OPN-760XL, No Adapters, No Security Cover	DM001000
OptiNID OPN-760XL, No Adapters, Security Cover	DM001022
ACCESSORIES ³	
3/4" Pipe Fitting Transition Kit (includes 2)	DM001174
OPN-760XL Security Cover Kit	DM000923
OPN-760XL Pole Mounting Kit	DM000927

Notes:

1. All standard OPN-760XL configurations come equipped with four slip-in rubber grommets and a splice tray equipped for 32 single fusion splices.
2. Contact AFL customer service for additional configurations.
3. See OptiNID Accessory Page for additional kits.

OptiNID® Optical Demarcation Accessories

Fiber Demarcation



Heyco Compression Fittings for OPN-300 Series and OPN-500

Used on the bottom entry ports of the OPN-300 Series and OPN-500 for a tight compression fitting. The Heyco M3234 fits into the larger left port and can compress from 18 mm to 11 mm in port size. The Heyco M3231 fits into the smaller middle and right ports and can compress from 11 mm to 4 mm. Kits include nylon locknuts.

Ordering Information

DESCRIPTION	AFL NO.
Heyco M3234 Compression Fitting, 18 mm to 11 mm Grip (includes 4). Left Port Only	DM001171
Heyco M3231 Compression Fitting, 11 mm to 4 mm Grip (includes 4). Middle and Right Port	DM000911



NPT Conduit Fittings for OPN-300 Series and OPN-500

Used on the bottom entry ports of the OPN-300 series and OPN-500 as an open port or to accept NPT conduit. The 3/4" NPT fitting has a through-hole size of 0.71" and can accept 3/4" NPT conduit. The 1/2" NPT fitting has a through-hole size of 0.51" and can accept 1/2" NPT conduit. Kits include nylon locknuts.

Ordering Information

DESCRIPTION	AFL NO.
3/4" NPT Conduit Fitting (includes 4) – Left Port Only	DM001170
1/2" NPT Conduit Fitting (includes 4) – Middle and Right Port	DM000912



Rubber Grommet for OPN-300 Series and OPN-500

Used on the middle and right entry ports of the OPN-300 series and OPN-500. The rubber grommets can be easily inserted to create a grommetted entry port or to seal an unused port.

Ordering Information

DESCRIPTION	AFL NO.
Rubber Grommet, 0.875" (includes 10)	DM001119

continued
→

Opti-NID® Optical Demarcation Accessories



Splice Chip Kit for OPN-500

Used on the OPN-500 to add an additional splice chip to the splice area to increase the splice capacity to 12 single fusion splices. The chip has an adhesive back, allowing it to adhere to multiple locations within the box.

Ordering Information

DESCRIPTION	AFL NO.
Kit, Six-Position Splice Chip (includes 10)	DM000870



Pipe Transition Kit for OPN-760XL

Used on the OPN-760XL to create a 3/4" NPT transition fitting. The fitting slides into any of the four entry ports on the OPN-760XL and securely clips into place. The 3/4" NPT fitting has a through-hole size of 0.67" and can accept 3/4" NPT conduit.

Ordering Information

DESCRIPTION	AFL NO.
3/4" Pipe Fitting Transition Kit (includes 2)	DM001174



Security Cover Kit for OPN-760XL

Used on the OPN-760XL to create a lockable security cover for provider access. The cover fits over the back portion of the OPN-760XL, covering the splice tray and provider side of the adapters and locks into place with a star head bolt.

Ordering Information

DESCRIPTION	AFL NO.
OPN-760XL Security Cover Kit	DM000923



Pole Mounting Kit for OPN-760XL

Used on the OPN-760XL to provide an easy pole mounting solution. The plate mounts to the back of the OPN-760XL and provides arms for straps or bolts to adhere to a pole.

Ordering Information

DESCRIPTION	AFL NO.
OPN-760XL Pole Mounting Kit	DM000927



CableGuard 1000XL Coax Demarcation Enclosures

The CableGuard CG-1000XL Coax Demarcation Enclosure provides a secure compartment for terminating coax, and mounting splitters and/or a ground blocks. Constructed of a weather-resistant/high impact thermoplastic alloy, the hinged cover design allows easy access, while the self-sealing individual entrance ports prevent water and insects from entering. The organized mounting arrangements not only create a standardized method for high quality drop installations, but also allow future expandability.

Features

- Weather-resistant/high impact thermoplastic alloy
- Self-latching, hinged cover design allows easy access without loose parts
- Organized internal mounting bosses create a standardized mounting arrangement and allow for proper bend radius of coax cable up to RG-6
- Upgradeable/separate secure subscriber compartment
- Upgradeable telephony demarcation
- Self-sealing individual entrance ports prevent water and insects from entering
- Optional custom logo
- Optional secure ground block protection

Specifications

PARAMETER	VALUES
Dielectric Strength	Minimum 2500 Vrms for 1 minute
Torque (mounting bosses)	20 in./lbs.
High Temperature Storage/Mold Stress °F (°C)	14 days at 159 (70.55)
Temperature Cycling with Humidity °F (°C)	150 day cycling from 40 to 140 (4.44 to 60) with 95% RH
Impact Test °F (°C)	-40 (-40), 5 ft./lbs. on all external surfaces
Drop Test °F (°C)	-40 (-40), 5 ft. (152.4 cm) onto concrete surface 4 times
Rain	24 hours at 10 psi
UV Resistance (Days Exposed)	60
Salt Fog (Days Exposed)	60
Chemical Resistance	30 Days at 100°F and 95% RH, Resists chipping and/or cracking when subject to: house paint, wasp spray, sulfuric acid, kerosene and sodium hydroxide
Material	UL® listed flame retardant thermoplastic alloy
Dimensions (H x W x D) in. (cm)	9.00 x 9.00 x 5.25 (22.80 x 22.80 x 13.34)
Cable Entrances in. (cm) diameter - Output	5 x 0.625 (1.5)
Cable Entrances in. (cm) diameter - Input	1 x 0.625 (1.5), 1 x 0.250 (0.6) (ground wire)
Covers	Molded in snap finger and 3/8" hex head fastener or F term

Ordering Information

MODEL NO.	AFL NO.
CG-1000 XL, F Terminator Security (not included)	DM000336

Qualifications

GOVERNING BODY	STANDARD CODE	COMPONENT
ASTM	G26-84, BLL7-90	Base and Cover
UL	94-5V	Base and Cover

Contact AFL for further details.

IDEAA® (Integrated Distribution Enabling Access Apparatus)



288 Fiber (Closed)

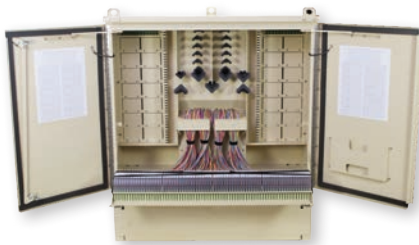

864 Fiber (Open)

IDEAA Exterior Distribution Cabinet

The IDEAA Exterior Distribution Cabinet (EDC) provides a convenient modular approach to centralized fiber distribution. All sizes of the EDC utilize the IDEAA splitter module to enable versatility across the platform. The EDC utilizes innovative jumper routing to enable efficient fiber management utilizing equal length pigtails for the entire cabinet.

Features

- Modular distribution platform allows for incremental deployment costs and immediate cost savings
- Small size is unobtrusive in residential deployments
- Enhanced fiber management provides simplified routing and termination
- Dual-door entry allows easy access to distribution and fiber management fields
- Flexible pad and pole mounting options allow for deployment in convenient locations
- Expandable feeder cables allow for point-to-point distribution (cross-connect)

Specifications

THROUGH PORTS	HEIGHT	WIDTH	DEPTH	SPLITTER CAPACITY	INPUT/PASS
Up to 288 Fiber	38"	20"	20"	9	24
432 Fiber	46"	20"	20"	14-15	24 (48 available)
576 and 864	48"	42.5"	20"	28	144

Ordering Information

DESCRIPTION	AFL NO.
PAD MOUNT WITH SKIRT AND 100 FOOT TAILS	
IDEAA Exterior Distribution Cabinet - 72 Pad, 1 x 72 Fiber Distribution Cable (Loose Tube), 1 x 24 Fiber Input Cable (Loose Tube)	EA000307
IDEAA Exterior Distribution Cabinet - 144 Pad, 1 x 144 Fiber Distribution Cable (Loose Tube), 1 x 24 Fiber Input Cable (Loose Tube)	EA000304
IDEAA Exterior Distribution Cabinet - 216 Pad, 1 x 216 Fiber Distribution Cable (Loose Tube), 1 x 24 Fiber Input Cable (Loose Tube)	EA000305
IDEAA Exterior Distribution Cabinet - 288 Pad, 1 x 288 Fiber Distribution Cable (Loose Tube), 1 x 24 Fiber Input Cable (Loose Tube)	EA000301
IDEAA Exterior Distribution Cabinet - 432 Pad, 2 x 216 Fiber Distribution Cable (Loose Tube), 1 x 24 Fiber Input Cable (Loose Tube)	EA000321
IDEAA Exterior Distribution Cabinet - 864 Pad, 2 x 432 Fiber Distribution Cable (Wrapping Tube Cable (WTC), with SpiderWeb Ribbon®), 1 x 144 Fiber Input Cable (Wrapping Tube Cable (WTC), with SpiderWeb Ribbon®)	EA000590

POLE MOUNT WITH BRACKET AND 100 FOOT TAILS	
IDEAA Exterior Distribution Cabinet - 144 Pole, 1 x 144 Fiber Distribution Cable (Loose Tube), 1 x 24 Fiber Input Cable (Loose Tube)	EA000314
IDEAA Exterior Distribution Cabinet - 288 Pole, 1 x 288 Fiber Distribution Cable (Loose Tube), 1 x 24 Fiber Input Cable (Loose Tube)	EA000302
IDEAA Exterior Distribution Cabinet - 432 Pole, 2 x 216 Fiber Distribution Cable (Loose Tube), 1 x 24 Fiber Input Cable (Loose Tube)	EA000322

Qualifications

GOVERNING BODY	STANDARD CODE
Telcordia	GR-3215



Applications

- Direct Wall Mount
- Interior Wall Mount Enclosure / Pedestal
- Exterior Wall Mount Enclosure
- Exterior Distribution Enclosure / Pedestal
- Exterior Distribution Cabinet
- Splice Closure – Sealed
- Rack Mount Bracket

Features

- SC and LC Module configurations can accommodate up to a 64 fiber distribution
- Modular design allows for highly flexible and scalable deployments
- Durable hardened plastic exterior provides a rugged encasement
- Single and multi-package modules available

IDEAA®

Integrated Distribution Enabling Access Apparatus

AFL's Integrated Distribution Enabling Access Apparatus (IDEAA) product family revolutionizes the way passive optical splitters are deployed in the network. Utilizing a small modular design and leveraging planar waveguide technology to yield an ultra low polarization dependent loss, low insertion loss, and high port uniformity, the IDEAA product possesses the flexibility to be used in a wide variety of applications. The IDEAA module provides a lower cost and more versatile alternative to preexisting PON architecture arrangements. Rather than being confined to a traditional "splitter-in-cabinet" design, the IDEAA product family allows service providers to employ PON architecture across all areas of the network.

The IDEAA module's unique design enables customers to utilize a revolutionary stand-alone mounting capability. In addition to conforming to a number of different applications, each IDEAA module can be mounted as an independent distribution point. This unit can be neatly secured to a wall or even placed on an existing rack or cabinet.

IDEAA SC and LC Modules

The IDEAA SC and LC modules come equipped with an internal PLC device which is factory terminated and tested. An integrated hinge provides easy access to the SC or LC adapter interface while reducing space when mounted. The SC and LC modules use APC connectors to meet the strict back reflection requirements of the latest PON architectures. A wide variety of PLC splitter configurations are available. A dual 1x16 module is available with SC APC outputs and LC APC inputs. Two SC APC to LC APC jumpers are included to connect to the EDC SC APC input ports.

Direct Wall Mount Capability

The IDEAA product can easily mount to an interior wall without needing any additional enclosures. Simply use the integrated hinge plate to install the module directly to a wall. The module contains port identification for each output fiber.

Specifications

PARAMETER	VALUE				
	1 X 4	1 X 8	1 X 16	1 X 32	1 X 64
Wavelength Range (nm)	1260 - 1650				
Typical Insertion Loss (dB)	6.7	9.8	12.9	16.6	19.8
Max Insertion Loss (dB)	7.4	10.5	14	17.5	21
Max IL Uniformity (dB)	1	1	1.5	2	2.2
Return Loss (dB)	≥55				
Directivity (dB)	≥55				
Max PDL (dB)	0.3				

Ordering Information

DESCRIPTION	AFL NO.
IDEAA MODULE, SC, 1X32	EA000102
IDEAA MODULE, SC OUTPUT, LC INPUT, DUAL 1x16	EA000583
IDEAA MODULE, SC, 1X16	EA000103
IDEAA MODULE, SC, 1X8	EA000104
IDEAA MODULE, SC, 1X4	EA000105
IDEAA MODULE, LC, 2X32	EA000547

Qualifications

GOVERNING BODY	STANDARD CODE
Telcordia	GR-1209, GR-1221

IDEAA® (Integrated Distribution Enabling Access Apparatus)



LL-400sx Optical Splicing/Distribution Enclosure

The LightLink (LL) 400sx Fiber Optic Splicing and Distribution Enclosure provides for organizing, splicing, and interconnecting fibers in FTTx, broadband, distribution and building entrance applications. Each LL-400sx enclosure features a scratch resistant powder coated aluminum base and a fully gasketed cover. A unique self-sizing grommet design allows for express and preterminated cable installation. The LL-400sx is a butt-style enclosure equipped with four independent cable entry/exit grommets, used for outdoor pedestal or indoor building entrance and riser splicing applications. The unit supports a maximum storage and splicing capacity of up to 192 single or 576 mass-fused fibers.

The LL-400sx can also mount up to two LGX118® adapter plates (splicing capacity limited to 144 single fusion and 432 mass fusion splices when adapter plates are installed).

Features

- Independent cable strain relief system
- Cable entry/exit grommet seals
- Removable Hinged Front Cover
- Fiber routing system
- Splice tray support system
- 192 single fusion splices
- 576 mass fusion splices
- Grounding hardware kit included
- 1 1x32 IDEAA Module with LGX Mount Bracket

Specifications

PARAMETER	VALUE
Material	Chassis – aluminum
Coatings	Electrostatically applied, powder coat
Color	Antique white
Dimensions (H x W x D) in. (cm)	23.9 x 9.5 x 5.0 (58.4 x 24.13 x 12.7)
Weight lbs (kg)	5.0 (2.3)

Ordering Information

DESCRIPTION	AFL NO.
LL-400sx	EA000370
LL-4848 Mass Fusion Splice Tray	911437-00-02
LL-2448 Universal Splice Tray	911289-00-02
LL-2448-48S Single Fusion Splice Tray	FA000045
LL-2400 Single Fusion Splice Tray	91710-06
Channel MAH1010 Pedestal	FM000776
Channel MAH1212 Pedestal	FM000655
IDEAA® Module LGX Mount Bracket	EA000061
IDEAA Pigtail Kit	EA000166
IDEAA SC/APC 1x32 Splitter Module	EA000102
IDEAA SC/APC 1x16 Splitter Module	EA000103
IDEAA SC/APC 1x8 Splitter Module	EA000104
IDEAA SC/APC 1x4 Splitter Module	EA000105

Applications

- OSP Splicing
- MDU Splicing
- FTTx Distribution



IDEAA® Rack Mount Bracket

The IDEAA RMB allows attachment of one (1) IDEAA module to easily mount to industry standard LGX® 118 fiber management rack panels. Simple push-pull pins allow the module to be easily installed and removed.

Features

- Metal plate with push/pull pins
- Powder coated black
- LGX compatible

Capacity

IDEAA MODULE	1RU PANEL	2RU PANEL	3RU PANEL	4RU PANEL
# of 118 Positions	3	6	9	12
1x32 SC	N/A	N/A	3	4
1x16 SC	N/A	3	3	6
1x8 and 1x4 SC	3	6	9	12
3x96 MPO	3	6	9	12

Ordering Information

DESCRIPTION	AFL NO.
Rack-mount Panel LGX®118 Bracket for SC/APC IDEAA Module	EA000654
Rack-mount Panel LGX®118 Bracket for MPO IDEAA Module	EA000655

IDEAA® (Integrated Distribution Enabling Access Apparatus)

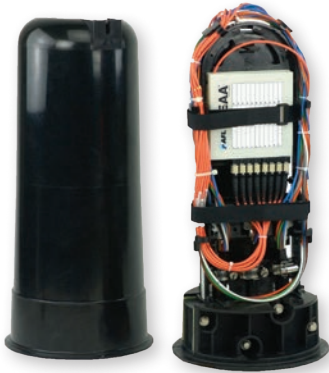

IDEAA® Splice Closure—Sealed

The IDEAA SCS is designed to mount either in buried or aerial applications. The splice closure comes equipped to install one (1) IDEAA module along with a tray to splice all input and output fiber cables. The splice closure is designed to handle multiple fiber cables.

Features

- Less than 20" overall length; ideal for small hand-holes
- Installation and re-entry using common hand tools
- Fully sealed to protect fiber and splices
- Fully kitted with all parts necessary for installation

Specifications

PARAMETER	VALUE
Splice Capacity (Max.) – single	36
Number of Splice Trays (Max.) – single	1
Cable Entrance Configuration	Butt
Cable Ports	5 Ports (14 cables total using flat-drop grommets)
Cable Sizes (O.D.)	Express Side – 2 (0.4"–1.0") Drop Side – 12 (0.31" flat-drop or 0.25" round)
Dimensions (L x D) – inches (cm)	19.8" x 10.0" (50.3 x 25.4)
Weight - lbs. (kg)	12 (5.44)

Ordering Information

DESCRIPTION	AFL NO.
IDEAA SPLICE CLOSURE	EA000076
IDEAA Splice Closure Pigtail Kit	EA000168



144 Fiber (Closed)

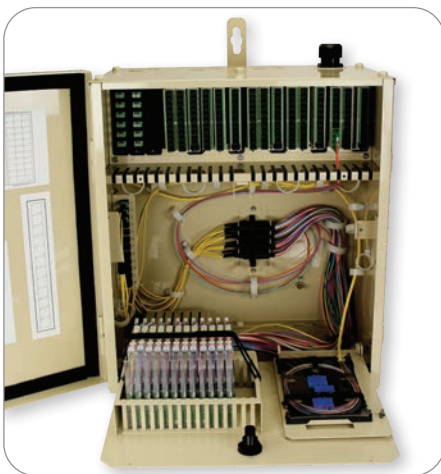

144 Fiber (Open)



288 Fiber (Open)

IDEAA® Interior Distribution Cabinet

The IDEAA Interior Distribution Cabinet (IDC) provides a convenient modular approach to centralized fiber distribution in medium to large MDUs. All sizes of the IDC utilize the IDEAA splitter module to enable versatility across the platform. The IDC utilizes innovative jumper routing to enable efficient fiber management utilizing equal length pigtails for the entire cabinet. The IDEAA IDC provides MDU fiber distribution in an extremely compact size.

Features

- MPO/MTP distribution field for connection to preconnectorized MPO riser cables or cables terminated with the AFL's MPO FUSEConnect®
- Extremely compact size limits footprint in telecom and electrical closets
- Dedicated fiber management pathways provide simplified and clean fiber routing
- Unobtrusive splice tray holder for splicing input/output fibers
- Multiple entry points allows for conduit fittings, compression fittings and home-runned 4.8 or 3.0 mm drop cables
- Keyhole external tabs for easy wall-mounting

Specifications

THROUGH PORTS	HEIGHT	WIDTH	DEPTH	SPLITTER CAPACITY	INPUT/PASS
72-144	21.7"	19"	12.5"	5	12
288	24.3"	30"	15.2"	9	24
432	32.7"	30"	15.2"	14-15	24 (48 Available)

Ordering Information

DESCRIPTION	AFL NO.
IDEAA Interior Distribution MDU Cabinet, 72 Fiber, MPO Enabled—includes one LL-4808L-R Universal Splice Tray for input fiber splicing	EA001025
IDEAA Interior Distribution MDU Cabinet, 96 Fiber, MPO Enabled—includes one LL-4808L-R Universal Splice Tray for input fiber splicing	EA001026
IDEAA Interior Distribution MDU Cabinet, 144 Fiber, MPO Enabled—includes one LL-4808L-R Universal Splice Tray for input fiber splicing	EA000783
IDEAA Interior Distribution MDU Cabinet, 288 Fiber, MPO Enabled—includes One LL-4896L-R Universal Splice Tray for input fiber splicing	EA000742
IDEAA Interior Distribution MDU Cabinet, 432 Fiber, MPO Enabled—includes One LL-4896L-R Universal Splice Tray for input fiber splicing	EA000749
LL-4896 Splice Tray—Stores (96) single fusion splices or (24) 288 mass fusion for 288/432 IDC	911676-00-02
LL-4808 Splice Tray—Stores (36) single fusion splices or (12) 144 mass fusion for 144 IDC	FA000037

Qualifications

GOVERNING BODY	STANDARD CODE
Telcordia	GR-3215

IDEAA® Interior Distribution Cabinet Accessories



Heyco Compression Fittings for IDEAA® Interior Distribution Cabinet

Used on the entry ports of the IDEAA IDC Cabinets after opening the knockout. Kits include 5 fittings and nylon locknuts.

Ordering Information

DESCRIPTION	AFL NO.
Heyco M3231 Fitting, 0.17" - 0.45" for 1/2" Knockout	EA000795
Heyco M3200 Fitting, 0.26" - 0.55" for 1/2" Knockout	EA000796
Heyco M8439 Fitting, 0.49" - 0.79" for 1" Knockout	EA000797
Heyco M8437 Fitting, 0.59" - 1.00" for 1" Knockout	EA000798
Heyco M8437GBK-SM Multihole Fitting, Holds 8 FDT Tails for 1" Knockout	EA000799



Mini IDC (Closed)



Mini IDC (Open)

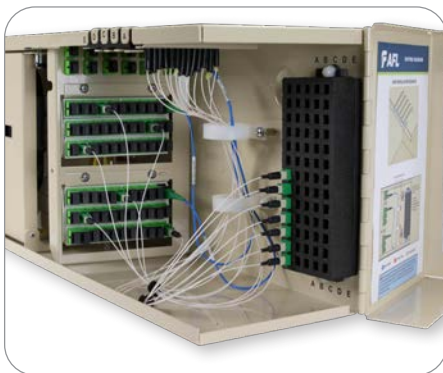

Detailed Drop Routing and Connector Storage

IDEAA® Mini Interior Distribution Cabinet

The IDEAA Mini Interior Distribution Cabinet (Mini IDC) provides a convenient and extremely compact modular approach to centralized fiber distribution in small MDUs. The Mini IDC provides up to 64 home run-drop output connections using two 1x32 IDEAA Splitter Modules. The Mini IDC utilizes innovative jumper routing and drop strain relief to enable efficient fiber management. Because of the adapter interface of the IDEAA splitter module, no additional interconnection is needed between the splitter and drop cables, allowing for MDU splitting and drop fiber distribution in an extremely compact size. The Mini-IDC also provides a convenient and innovative way to store connectors from installed drops not yet ready for active service. Clear labeling allows connectors to be easily identifiable so they can be removed and connector to splitter ports when ready for service.

Features

- Designed for one or two IDEAA splitter modules for up to 64 subscriber connections using 1x32 splitters
- Extremely compact size limits footprint in telecom and electrical closets
- Dedicated fiber management pathways provide simplified and clean fiber routing
- Unobtrusive splice tray holder for splicing input fibers
- Integrated strain relief for 4.8 mm or 3.0 mm MDU drop cables
- Internal keyholes for easy wall-mounting
- Connector storage area for convenient housing and identification for disconnected drops

Specifications

THROUGH PORTS	HEIGHT	WIDTH	DEPTH	SPLITTER CAPACITY	INPUT/PASS
Up to 64 Fiber	9.25"	18"	6.25"	2	12

Ordering Information

DESCRIPTION	AFL NO.
IDEAA Mini Interior Distribution MDU Cabinet, 32-64 Fiber — Includes one LL-2425 Single-Fiber Splice Tray for input fiber splicing (input pigtailed included)	EA000968
Heyco M3231GZA Fitting for Flat Drop Cable (includes 5)	EA000794
Heyco M3231 Fitting, 0.17" - 0.45" (includes 5)	EA000795
Heyco M3200 Fitting, 0.26" - 0.55" (includes 5)	EA000796

Qualifications

GOVERNING BODY	STANDARD CODE
Telcordia	GR-3215



Sealed Fiber Optic Splice Closures

AFL's sealed fiber optic splice closures are designed to simplify splice management and maintenance. Intuitive engineering design reduces the installation time and complexity associated with fiber splicing in the field. No heat, adhesives, drills or powered equipment for installation or re-entry are required, just simply use a common can wrench to access and install cable. These closures are durable, easy-to-install and will increase productivity, reduce labor expenses, and last the life of your plant.

Features

- LG Series closures support stranded loose tube, Uniflex or ribbon fiber cables in either armored or dielectric configurations
- New Apex® Sealed Closures also support "rollable ribbon" fiber types including AFL's SpiderWeb Ribbon® (SWR®)
- Fully sealed to protect fiber and splices ensuring longevity
- Fully kitted with all parts to install cables

Specifications

DESCRIPTION	MODEL							
	LG-55-U-0	APEX X-2	APEX X-2S	LG-150-U-0	LG-250-U-0	LG-350-U-0	LG-350-AC	LG-350XL-U-0
Splice Capacity (Max.) – Single, Mass, Mechanical	24, n/a, 24	432, 3456, 864	216, 1728, 432	48, 192, 48	144, 432, 48	480, 1152, 108 ²	144, 432, 48	864, 2592, 288
Number of Splice Trays (Max.) – Single, Mass, Mechanical	1, n/a, 1	6		4, 3, 4		12, 8, 8	4, 3, 4	9, 9, 9
Cable Entrance Configuration	In-line / Butt	Butt						
Cable Ports	2	6		5			2 (Express Grommets) 3 (4-Drop Grommets)	5 (7 using dual port grommet Express sides)
Cable Sizes (Max. O.D.) in. (mm)	2 @ 0.70 (17.78) (splice)	Single Port: 0.40- 1.10 (10.0 - 28.0) Multi-Drop Kit: 0.20 - 0.39 (5.0 - 9.9) or flat drop		5 @ 0.62 (15.748)		3 @ 0.80 (20.32) 2 @ 1.00 (25.4)	2 @ 1.0 (25.4) 12 @ 0.312 (7.9248) Flat or 0.250" (6.35) Round	3 @ 1.08 (27.432) 2 @ 1.18 (29.972)
Testing - Cable Retention (100 lbs) - Water Resistance (waterhead) - Impact Resistance (0-40 °C) - Chemical Resistance - Cable Flexing	Passed 20 ft. Passed Passed Passed	—	—				Passed 20 ft. Passed Passed Passed	
Dimensions – (L x D) in. (mm)	14.00 x 4.00 (35.6 x 10.16)	25.0 x 12.0 (64 x 30)	20.0 x 12.0 (51 x 30)	16.25 x 8.75 (412.75 x 222.3)	19.0 x 8.75 (482.6 x 222.3)	28.00 x 10.00 (71.12 x 25.4)	20 x 10 (51 x 25.4)	31.00 x 12.00 (78.74 x 30.48)
Weight – lbs. (kg)	3.0 (1.36)	25 (11.3)	22 (10)	10.5 (4.76)	10.5 (4.76)	16 (7.26)	12.0 (5.44)	25 (11.34)

NOTES: 1. For the LG-250-U-0; 36 mechanical splices only using the LL-2448 splice tray.
2. For the LG-350-U-0; 108 mechanical splices only using the LL-2448 splice tray.

Qualifications

GOVERNING BODY	STANDARD CODE
Telcordia	GR-771
Rural Utilities Service (RUS)	Listed

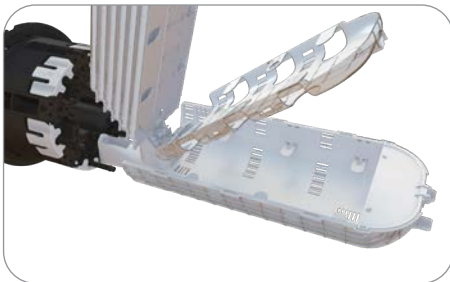

Open to access Apex X-3 splice trays and lock at 72 degrees

Apex® X-3 Sealed Splice Closure

The Apex X-3 is a sealed splice closure designed for protecting optical fiber splices in both above- or below-grade applications in a butt configuration. The Apex X-3 is capable of up to 864 single fusion, 1296 mass fusion with standard ribbon, or 5184 (200 μm, 2592 max for 250 μm) mass fusion with “rollable ribbon” fiber types such as AFL’s SpiderWeb Ribbon® (SWR®). Cables are sealed by a unique wedge system spaced evenly around the circumference of the closure’s base. Each cable seal is opened by a press-to-release lever and sealing is completed by actuating a single screw for each cable. Each cable is sealed individually, ensuring original craftsmanship when cables may be added at a later date. Up to 6 splice trays are attached and hinge off a central organizer. A plastic slack storage basket resides underneath the trays with ample tie down points for managing tube and fiber slack.

Features

- Individual cable sealing ports with tool-less release mechanism and gel sealing
- Hinging, lockable splice trays
- Plastic slack storage basket with optional segmented basket to separate ribbon and loose tube slack storage
- Six cable ports with up to six ground lugs
- Capable of up to 16 drop cables with an expressed distribution cable using multi-drop entry kits
- Splice trays with universal splice modules capable of holding single fusion, mass fusion and mechanical splices as well as other devices such as passive optical splitters
- Dome-to-base O-ring seal retained into dome to prevent loss or damage, but is still replaceable if necessary

Specifications

PARAMETER	VALUE
Dimensions – L x D, in (cm)	32.0 x 14 (81.3 x 35.6)
Weight, No Trays – lb (kg)	30 lbs. (13.61 kg)
Splice Capacity – Single, Mass (SWR), Mass (Standard)	864, 5184, 1296
Splice Tray Capacity	6
Cable Diameter, Single Port, in (mm)	0.40" - 1.38" (10.16 - 35.052)
Cable Diameter, Multi-Drop Kit, in (mm)	0.20" – 0.39" (5.0 – 9.9) or flat drop
Application	Direct Bury, Handhole, Aerial, Pole/Wall
Designed in accordance with Telcordia GR-771	Up to 10 ft. water-head

Apex® X-3 Sealed Splice Closure

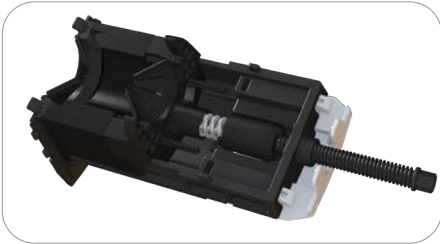

Gel Sealing

Individual wedges located evenly around the circumference of the base are removed with the press of a button. When cables are in place and ready to be sealed, the gel is compressed by a single screw, decreasing installation time. Individual port seals ensure cables never become unsealed when adding new cables at a later date.

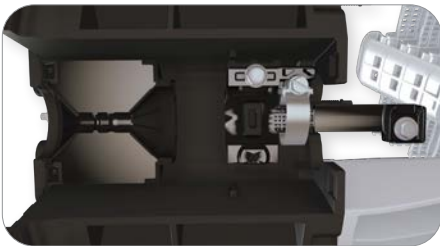

Cable Entry Ports and Cable Attachment Unit (CAU)

The cable entry ports surrounding the circumference of the base accept single cables from 0.4" to 1.38" in diameter. These ports can be expanded through the use of optional drop cable entry kits, allowing up to 4 flat drops or cables from 0.2" to 0.39" to use a single port. Additionally, each port has the capability to be paired with its own grounding lug if necessary. Closures can be configured with enough CAU kits for 0 to 6 cables from the factory. For closures with less than 6, additional cables can be added through the use of additional cable strain relief kits sold separately.

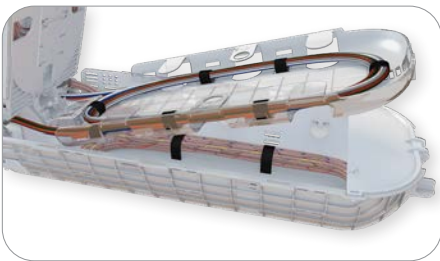

Slack Storage

A molded slack storage basket allows for use of the entire cross section of the closure to maximize storage. An optional segmented hinging basket is available to separate ribbon and loose tube slack, and can be locked in the upward position for access to expressed fibers below.

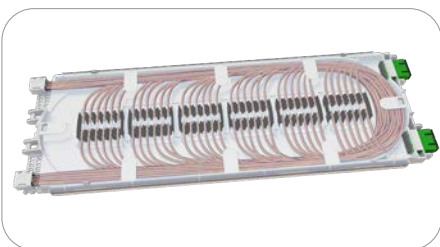

Splice Trays with Modular Splice Holders

Splice trays are organized in a hinging array that automatically lock when tilted to the upward position for easy access to the splice trays and slack storage below. The universal splice module holds up to 24 single fusion quad-stacked, 6 mass fusion or 12 mass fusion double-stacked when using SWR, or 6 mechanical splices as well as devices such as PLC splitters. This eliminates the need for specifying and stocking multiple splice trays for multiple applications such as WDM and PLC Splitters, (photo at left shown with ASC bulkhead test ports installed). This can be mix-and-match.

Ordering Information

AX	3	B	L	0	2	6	B
APEX CLOSURES	CLOSURE SIZE	BASKET TYPE	TRAY TYPE	NUMBER OF TRAYS	CABLE STRAIN RELIEF HARDWARE KITS	NUMBER OF GROUND LUGS	INNER BASKET
	3 = X-3 Size	B = X-3 Sized Basket	X = No preinstalled tray L = X-3 Square Tray Loaded with splice modules	0 1 2 3 4 5 6	0 1 2 3 4 5 6	0 1 2 3 4 5 6	X = No Inner Basket B = Include Inner Basket

Apex® X-3 Sealed Splice Closure

Splice Trays and Splice Modules

Apex X-3 closures utilize X-3 square splice trays. Trays can be ordered empty or fully loaded with splice modules. For "rollable" type ribbon such as AFL's SpiderWeb Ribbon®, closures can be fully loaded with 6 splice trays for 5184 SWR or 864 quad-stacked single fiber splices or 144 fibers per tray. For standard ribbon, AFL recommends half loaded for 18 mass splices single-stacked, or 216 fibers per tray.

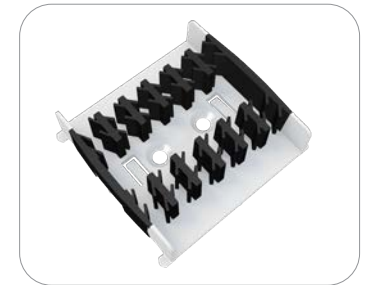
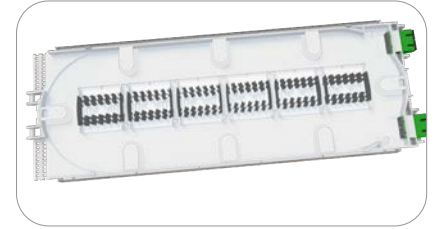

Ordering Information

DESCRIPTION	TRAY CAPACITY		AFL NO.
	SINGLE	MASS	
X-3 Tray Fully Loaded with Six (6) Splice Modules (864 fibers per tray only recommended for rollable ribbon, e.g. AFL SWR)	108 triple stacked 144 quad stacked**	864**	AX-TRAY-3-S-6
Additional splice module (18 single fusion double/quad stacked, 12 mass fusion double stacked, 6 mechanical) Pack of 20	–	–	AX-TRAY-MOD-20
X-3 Square Tray Empty	–	–	AX-TRAY-3-S-E
FP-40 40 mm Single Fiber Slim Protection Sleeve	–	–	S018262
FP-60 60 mm Single Fiber Slim Protection Sleeve	–	–	S018263

* 864 fibers per tray with mass fusion (5184 total closure capacity) only recommended for 200 µm type rollable ribbon. For 250 µm, cut capacity in half with single-stacking.

** When using AFL's Slim Protection Sleeves

Dimensions

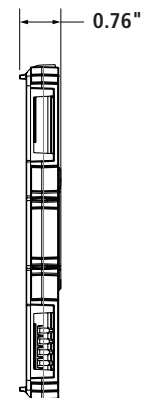
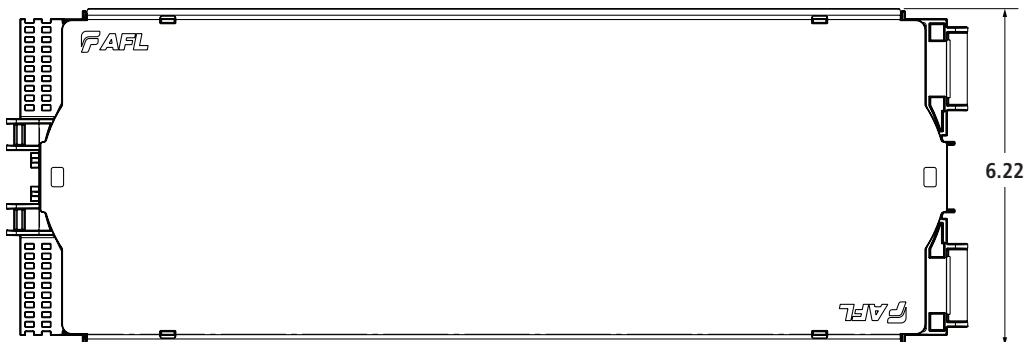
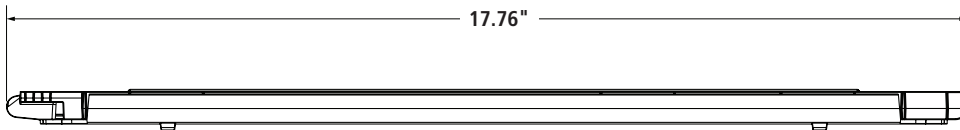

Apex® X-3 Sealed Splice Closure

Installation Kits and Accessories

The AFL Apex closure line has a variety of installation accessories kits to fit many applications. Additional accessories may be available. Contact AFL.



CAU Kit



Ring Clamp Replacement Kit



O-Ring Grease Kit



Wedge Replacement Kit

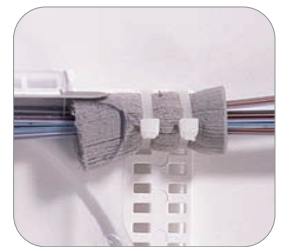

Foam Retention

Ordering Information — Replacement Kits

DESCRIPTION	AFL NO.
REPLACEMENT KITS	
X-3 and X-3H Single Cable Strain Relief/Cable Attachment Unit (CAU) Kit	AX-KIT-CBLSTRN-3
X-3 and X-3H Dome-to-Base Locking Ring Clamp Replacement Kit	AX-KIT-CLAMP-3
X-3 and X-3H Dome Replacement Kit	AX-KIT-DOME-3
X-3 and X-3H Inner Base Gel Replacement Kit	AX-KIT-GEL-3
X-3 Inner Basket Kit	AX-KIT-SBASKET-3
Apex O-Ring Grease, Pack of 10	AX-KIT-GREASE-10
X-3 and X-3H Dome to Base O-Ring Replacement Kit	AX-KIT-ORING-3
X-3 and X-3H Wedge Replacement Kit	AX-KIT-WEDGE-3
WTC-SWR Bundle Splice Tray Retention Kit - Includes 25 foam grommets for retaining SWR bundles to splice trays	HW000406
Velcro, 75 Foot Length Roll – For securing SWR bundles in the slack basket	FC001759



Apex Aerial Hanger Bracket



Apex Pole/Wall Mount



Adjustable Aerial Hanger Bracket



Mesh Transition Tubing



Universal Installation Stand

Ordering Information — Accessories

DESCRIPTION	AFL NO.
ACCESSORIES	
X-3 and X-3H Pole/wall mount kit	AX-BR33
Aerial strand mount hanger kit	AX-KIT-AERIAL-1
Adjustable Aerial Strand Mount Hanger kit	AX-KIT-AERIAL-ADJ
ADSS Aerial hanger brackets	AX-KIT-AERIAL-ADSS
X-3 and X-3H Multi-Drop Cable Entry Kit (fits up to 4 cables 0.20" to 0.39" in diameter or flat drop cable)	AX-KIT-DROP-4-3
Apex Internal Multiple Ground Bonding Kit	AX-KIT-GNDLD-5
Apex Cable Bonding Kit (Bonds armored cable sheath to ground) – Pack of 10	AX-KIT-GROUND-10
1/4" Colored Mesh Transition Tubing, 250' Spool (*Replace "XX" with color per TIA-598 color code - BL, OR, GR, BR, SL, WH, RD, BK, YL, VI, RS or AQ)	AX-KIT-TUBE-014-XX*
Apex Universal Installation Stand	AX-KIT-U-STAND

Apex® X-3 Sealed Splice Closure

Installation Accessories (cont.)

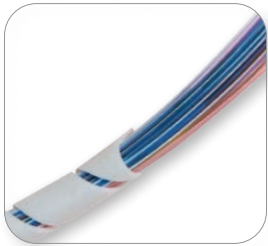

Silicone Spiral Wrap



AFRS Kit 1



AFRS Kit 2



SC Bulkhead Adapter Kit

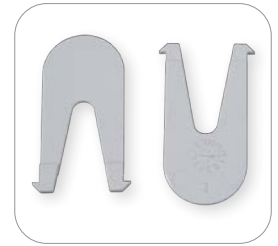

Replacement Slack Storage Basket Tabs

Ordering Information — Accessories

DESCRIPTION	AFL NO.
ACCESSORIES	
Silicone Spiral Wrap, 5.5 Foot Length	FC001657
Apex Advanced Fiber Retention System (AFRS) Kit 1 – Used for Ribbon Cable (Flat Matrix, SWR, Tubed, Central Core). Kit includes: Mesh Basket Adapter (2 ea.), Mesh Housing (2 ea.), Mesh Insert (24 ea.), V-Clips (12 ea.), and Clean Cut Gray Mesh (13 ft.).	AX-KIT-AFRSRBN
Apex AFRS Kit 2 – Used for Loose Tube Cable. Kit includes: V-Clip (24 ea.) and Retention Pads (6 sheets of 8 pads)	AX-KIT-AFRSLT
Apex AFRS Kit 3 – V-Clip bulk kit. Includes: V-Clips (120 ea.) and Mesh Inserts (120 ea.)	AX-KIT-AFRSVC-120
Apex AFRS Kit 4 – Mesh bulk kit. Includes: Clean Cut Gray Mesh (100 ft.)	AX-KIT-AFRSMESH-100FT
Apex AFRS Kit 5 – Mesh Housing bulk kit. Includes: Mesh Basket Adapter (10 ea.) and Mesh Housing (10 ea.)	AX-KIT-AFRSAH-10
Apex AFRS Kit 6 – Mesh Basket Adapter bulk kit. Includes: Mesh Basket Adapter (10 ea.)	AX-KIT-AFRSA-10
Apex Bulkhead Kit with Plate SC/APC Adapters, 1 kit	AX-TRAY-ASC
Apex Bulkhead Kit with Plate with SC/UPC Adapters, 1 kit	AX-TRAY-USC
Apex Bulkhead Kit with Plate SC/APC Adapters, 6 pc kit	AX-TRAY-ASC-6
Apex Bulkhead Kit with Plate SC/UPC Adapters, 6 pc kit	AX-TRAY-USC-6
Apex Replacement Slack Storage Basket Tabs – Pack of 25	AX-KIT-BTAB-25



Apex® X-3H Sealed Splice Closure

The Apex X-3H is a sealed splice closure designed for protecting optical fiber splices in both above- or below-grade applications in a butt configuration. The Apex X-3H is capable of up to 1728 mass fusion with standard ribbon or 6912 (200 μm, 3456 max for 250 μm) mass fusion with “rollable ribbon” fiber types such as AFL’s SpiderWeb Ribbon® (SWR®). Cables are sealed by a unique wedge system spaced evenly around the circumference of the closure’s base. Each cable seal is opened by a press-to-release lever and sealing is completed by actuating a single screw for each cable. Each cable is sealed individually, ensuring original craftsmanship when cables may be added at a later date. Up to 8 splice trays are attached and hinge off a central organizer. A plastic slack storage basket resides underneath the trays with ample tie down points for managing tube and fiber slack.



Features

- Individual cable sealing ports with tool-less release mechanism and gel sealing
- Hinging, lockable splice trays
- Plastic slack storage basket designed for high count WTC with SWR and other rollable ribbon cable
- Six cable ports with up to six ground lugs
- Optimized for 6912 200 μm fiber end splice
- Splice trays with universal splice modules capable of holding single fusion, mass fusion and mechanical splices as well as other devices such as passive optical splitters
- Dome-to-base O-ring seal retained into dome to prevent loss or damage, but is still replaceable if necessary

Specifications

PARAMETER	VALUE
Dimensions – L x D, in (cm)	32.0 x 14 (81.3 x 35.6)
Weight, No Trays – lb (kg)	30 (13.6)
Splice Capacity – Mass (SWR), Mass (Standard)	6912, 1728
Splice Tray Capacity	8
Cable Diameter, Single Port, in (mm)	0.40" - 1.38" (10.16 - 35.052)
Application	Handhole, Aerial, Pole/Wall, Direct Bury

Apex® X-3H Sealed Splice Closure



Gel Sealing

Individual wedges located evenly around the circumference of the base are removed with the press of a button. When cables are in place and ready to be sealed, the gel is compressed by a single screw, decreasing installation time. Individual port seals ensure cables never become unsealed when adding new cables at a later date.

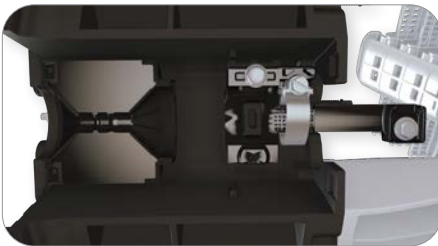

Cable Entry Ports and Cable Attachment Unit (CAU)

The cable entry ports surrounding the circumference of the base accept single cables from 0.4" to 1.38" in diameter. Additionally, each port has the capability to be paired with its own grounding lug if necessary. Closures can be configured with enough strain relief kits for 0 to 6 cables from the factory. For closures with less than 6, additional cables can be added through the use of additional cable strain relief kits sold separately.

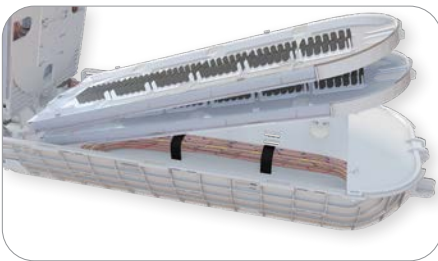

Slack Storage

A molded slack storage basket allows for use of the entire cross section of the closure to maximize storage.

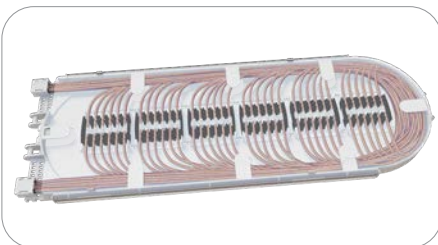

Splice Trays with Modular Splice Holders

Apex X-3H round splice trays are organized in a hinging array that automatically lock when tilted to the upward position for easy access to the splice trays and slack storage below. The Apex X-3H round splice trays are only compatible with the X-3H closure. The universal splice module holds up to 24 single fusion, 6 mass fusion or 12 mass fusion double-stacked when using SWR, or 6 mechanical splices as well as devices such as PLC splitters. This eliminates the need for specifying and stocking multiple splice trays for multiple applications.

Ordering Information

AX	—	3H	—	B	—	L	—	0	—	2	—	6	—	X
APEX CLOSURES		CLOSURE SIZE		BASKET TYPE		TRAY TYPE		NUMBER OF TRAYS		CABLE STRAIN RELIEF HARDWARE KITS		NUMBER OF GROUND LUGS		INNER BASKET
		3H = X-3H Size		B = X-3H Sized Basket		X = No preinstalled tray L = X-3 Square Tray Loaded with splice modules		0 OR 8		0 1 2 3 4 5 6		0 1 2 3 4 5 6		X = No Inner Basket

Apex® X-3H Sealed Splice Closure

Splice Trays and Splice Modules

Apex X-3H closures utilize X-3H round splice trays. Trays can be ordered empty or fully loaded with splice modules. For "rollable" type ribbon such as AFL's SpiderWeb Ribbon®, trays can be fully loaded for 72 double-stacked mass splices, or 864 fibers per tray. For standard ribbon, AFL recommends half loaded for 18 mass splices single-stacked, or 216 fibers.



Ordering Information

DESCRIPTION	MASS	AFL NO.
	X-3H Tray Fully Loaded with Six (6) Splice Modules (864 fibers per tray only recommended for rollable ribbon, e.g. AFL SWR)	864**
Additional splice module (18 single fusion triple stacked, 12 mass fusion double stacked, 6 mechanical) – Pack of 20	–	AX-TRAY-MOD-20
X-3H Round Tray Empty	–	AX-TRAY-3-R-E
FP-40 40 mm Single Fiber Slim Protection Sleeve	–	S018262
FP-60 60 mm Single Fiber Slim Protection Sleeve	–	S018263

* 864 fibers per tray with mass fusion (6912 total closure capacity) only recommended for 200 μm type rollable ribbon. For 250 μm, cut capacity in half with single-stacking.

** When using AFL's Slim Protection Sleeves

Dimensions

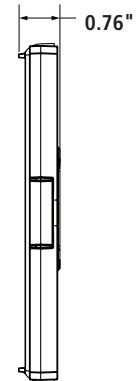
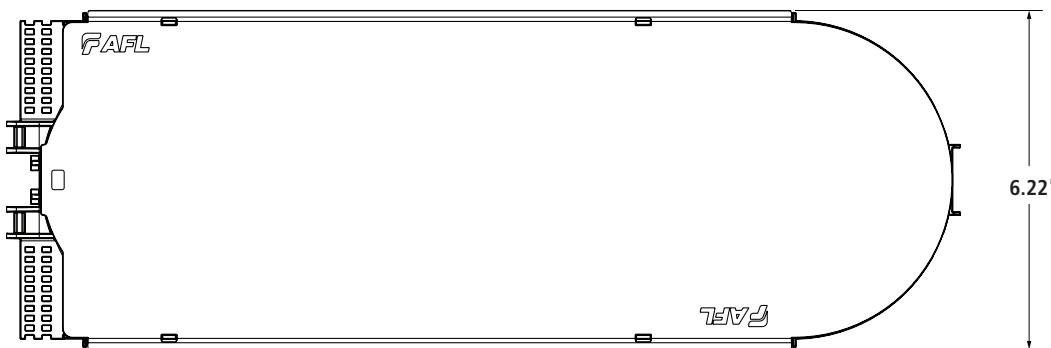
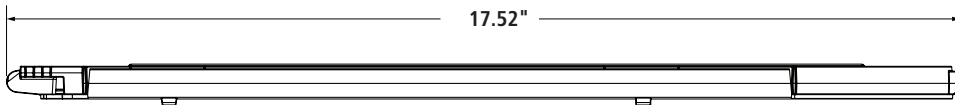

Apex® X-3H Sealed Splice Closure

Installation Kits and Accessories

The AFL Apex closure line has a variety of installation accessories kits to fit many applications. Additional accessories may be available. Contact AFL.



CAU Kit



Ring Clamp Replacement Kit



O-Ring Grease Kit



Wedge Replacement Kit

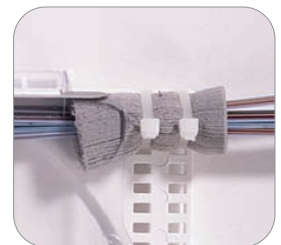

Foam Retention

Ordering Information — Replacement Kits

DESCRIPTION	AFL NO.
REPLACEMENT KITS	
X-3 and X-3H Single Cable Strain Relief/Cable Attachment Unit (CAU) Kit	AX-KIT-CBLSTRN-3
X-3 and X-3H Dome-to-Base Locking Ring Clamp Replacement Kit	AX-KIT-CLAMP-3
X-3 and X-3H Dome Replacement Kit	AX-KIT-DOME-3
X-3 and X-3H Inner Base Gel Replacement Kit	AX-KIT-GEL-3
Apex O-Ring Grease, Pack of 10	AX-KIT-GREASE-10
X-3 and X-3H Dome to Base O-Ring Replacement Kit	AX-KIT-ORING-3
X-3 and X-3H Wedge Replacement Kit	AX-KIT-WEDGE-3
WTC-SWR Bundle Splice Tray Retention Kit - Includes 25 foam grommets for retaining SWR bundles to splice trays	HW000406
Velcro, 75 Foot Length Roll – For securing SWR bundles in the slack basket	FC001759



Apex Aerial Hanger Bracket



Apex Pole/Wall Mount



Adjustable Aerial Hanger Bracket



Mesh Transition Tubing



Universal Installation Stand

Ordering Information — Accessories

DESCRIPTION	AFL NO.
ACCESSORIES	
X-3 and X-3H Pole/wall mount kit	AX-BR33
Aerial strand mount hanger kit	AX-KIT-AERIAL-1
Adjustable Aerial Strand Mount Hanger kit	AX-KIT-AERIAL-ADJ
ADSS Aerial hanger brackets	AX-KIT-AERIAL-ADSS
X-3 and X-3H Multi-Drop Cable Entry Kit (fits up to 4 cables 0.20" to 0.39" in diameter or flat drop cable)	AX-KIT-DROP-4-3
Apex Internal Multiple Ground Bonding Kit	AX-KIT-GNDLD-5
Apex Cable Bonding Kit (Bonds armored cable sheath to ground) – Pack of 10	AX-KIT-GROUND-10
1/4" Colored Mesh Transition Tubing, 250' Spool (*Replace "XX" with color per TIA-598 color code - BL, OR, GR, BR, SL, WH, RD, BK, YL, VI, RS or AQ)	AX-KIT-TUBE-014-XX*
Apex Universal Installation Stand	AX-KIT-U-STAND

Apex® X-3H Sealed Splice Closure

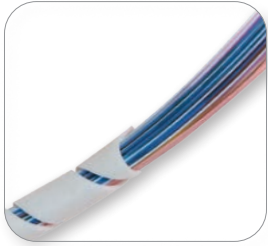

Silicone Spiral Wrap



AFRS Kit 1



AFRS Kit 2

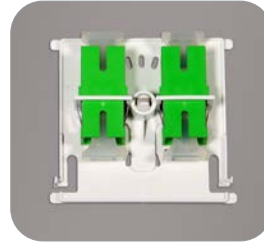

SC Bulkhead Adapter Kit

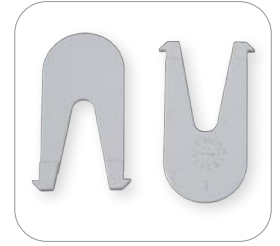

Replacement Slack Storage Basket Tabs

Ordering Information — Accessories

DESCRIPTION	AFL NO.
ACCESSORIES	
Silicone Spiral Wrap, 5.5 Foot Length	FC001657
Apex Advanced Fiber Retention System (AFRS) Kit 1 – Used for Ribbon Cable (Flat Matrix, SWR, Tubed, Central Core). Kit includes: Mesh Basket Adapter (2 ea.), Mesh Housing (2 ea.), Mesh Insert (24 ea.), V-Clips (12 ea.), and Clean Cut Gray Mesh (13 ft.).	AX-KIT-AFRSRBN
Apex AFRS Kit 2 – Used for Loose Tube Cable. Kit includes: V-Clip (24 ea.) and Retention Pads (6 sheets of 8 pads)	AX-KIT-AFRSLT
Apex AFRS Kit 3 – V-Clip bulk kit. Includes: V-Clips (120 ea.) and Mesh Inserts (120 ea.)	AX-KIT-AFRSVC-120
Apex AFRS Kit 4 – Mesh bulk kit. Includes: Clean Cut Gray Mesh (100 ft.)	AX-KIT-AFRSMESH-100FT
Apex AFRS Kit 5 – Mesh Housing bulk kit. Includes: Mesh Basket Adapter (10 ea.) and Mesh Housing (10 ea.)	AX-KIT-AFRSAH-10
Apex AFRS Kit 6 – Mesh Basket Adapter bulk kit. Includes: Mesh Basket Adapter (10 ea.)	AX-KIT-AFRSA-10
Apex Bulkhead Kit with Plate SC/APC Adapters, 1 kit	AX-TRAY-ASC
Apex Bulkhead Kit with Plate with SC/UPC Adapters, 1 kit	AX-TRAY-USC
Apex Bulkhead Kit with Plate SC/APC Adapters, 6 pc kit	AX-TRAY-ASC-6
Apex Bulkhead Kit with Plate SC/UPC Adapters, 6 pc kit	AX-TRAY-USC-6



Apex® X-2 Sealed Splice Closure

The Apex X-2 is a sealed splice closure designed for protecting optical fiber splices in both above- or below-grade applications in a butt configuration. The Apex X-2 is capable of up to 576 single fusion, 1152 mass fusion with standard ribbon, or 3456 (200 μm, 1728 max for 250 μm) mass fusion with “rollable ribbon” fiber types such as AFL’s SpiderWeb Ribbon® (SWR®). Cables are sealed by a unique wedge system spaced evenly around the circumference of the closure’s base. Each cable seal is opened by a press-to-release lever and sealing is completed by actuating a single screw for each cable. Each cable is sealed individually, ensuring original craftsmanship when cables may be added at a later date. Up to 6 splice trays are attached and hinge off a central organizer. A plastic slack storage basket resides underneath the trays with ample tie down points for managing tube and fiber slack.

Features

- Individual cable sealing ports with tool-less release mechanism and gel sealing
- Hinging, lockable splice trays
- Plastic slack storage basket with optional segmented basket to separate ribbon and loose tube slack storage
- Six cable ports with up to six ground lugs
- Capable of up to 16 drop cables with an expressed distribution cable using multi-drop entry kits
- Splice trays with universal splice modules capable of holding single fusion, mass fusion and mechanical splices as well as other devices such as passive optical splitters
- Dome-to-base O-ring seal retained into dome to prevent loss or damage, but is still replaceable if necessary

Specifications

PARAMETER	VALUE
Dimensions – L x D, in (cm)	25.0 x 12.0 (64 x 30)
Weight, No Trays – lb (kg)	25 (11.3)
Splice Capacity – Single, Mass (SWR), Mass (Standard)	576, 3456, 1152
Splice Tray Capacity	6
Cable Diameter, Single Port, in (mm)	0.40" – 1.10" (10.0 – 28.0)
Cable Diameter, Multi-Drop Kit, in (mm)	0.20"-0.39" (5.0-9.9) or flat drop
Application	Direct Bury, Handhole, Aerial, Pole/Wall
Testing	Test to and Passed GR-771-CORE 20 ft. Waterhead test
Temperature Operating	-40°F to 149°F -40°C to 65°C

Apex® X-2 Sealed Splice Closure

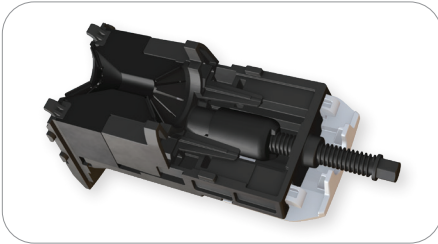

Gel Sealing

Individual wedges located evenly around the circumference of the base are removed with the press of a button. When cables are in place and ready to be sealed, the gel is compressed by a single screw, decreasing installation time. Individual port seals ensure cables never become unsealed when adding new cables at a later date.

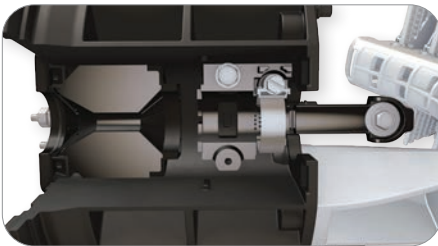

Cable Entry Ports and Strain Relief

The cable entry ports surrounding the circumference of the base accept single cables from 0.4" to 1.1" in diameter. These ports can be expanded through the use of optional drop cable entry kits, allowing up to 4 flat drops or cables from 0.2" to 0.39" to use a single port. Additionally, each port has the capability to be paired with its own grounding lug if necessary. Closures can be configured with enough strain relief kits for 0 to 6 cables from the factory. For closures with less than 6, additional cables can be added through the use of additional cable strain relief kits sold separately.



Slack Storage

A molded slack storage basket allows for use of the entire cross section of the closure to maximize storage. An optional segmented hinging basket is available to separate ribbon and loose tube slack, and can be locked in the upward position for access to expressed fibers below.

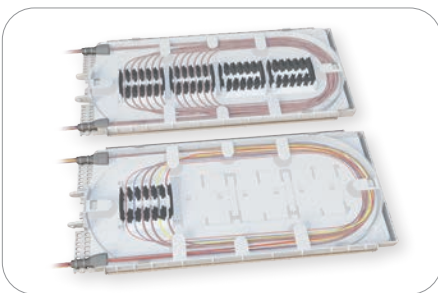

Splice Trays with Modular Splice Holders

Splice trays are organized in a hinging array that automatically lock when tilted to the upward position for easy access to the splice trays and slack storage below. The universal splice module holds up to 24 single fusion, 6 mass fusion or 12 mass fusion double-stacked when using SWR, or 6 mechanical splices as well as devices such as PLC splitters or OADM devices. This eliminates the need for specifying and stocking multiple splice trays for multiple applications.

Ordering Information

AX	2	B	L	0	2	6	B
APEX CLOSURES	CLOSURE SIZE	BASKET TYPE	TRAY TYPE	NUMBER OF TRAYS	CABLE STRAIN RELIEF HARDWARE KITS	NUMBER OF GROUND LUGS	INNER BASKET
	2 = X-2 Size	B = X-2 Sized Basket	X = No preinstalled tray L = X-2 Tray Loaded with splice modules	0 1 2 3 4 5 6	0 1 2 3 4 5 6	0 1 2 3 4 5 6	X = No Inner Basket B = Include Inner Basket

Apex® X-2 Sealed Splice Closure

Splice Trays and Splice Modules

Apex X-2 closures utilize X-2 size splice trays. Trays can be ordered fully loaded or half loaded with splice modules. For "rollable" type ribbon such as AFL's SpiderWeb Ribbon®, trays can be fully loaded for 48 double-stacked mass splices, or 576 fibers total per tray. For standard ribbon, AFL recommends partially loaded for up to 16 mass splices single-stacked, or 192 fibers. Adapter kits available to install FOOSC® A-B optical trays.

Ordering Information

DESCRIPTION	TRAY CAPACITY		AFL NO.
	SINGLE	MASS	
X-2 Tray Loaded with Two Splice Modules	48**	288	AX-TRAY-2-2
X-2 Tray Fully Loaded with Four Splice Modules (576 fibers per tray only recommended for rollable ribbon, e.g. AFL SWR)	96**	576*	AX-TRAY-2-4
Additional splice module (18 single fusion triple stacked, 12 mass fusion double stacked, 6 mechanical) – Pack of 20	–	–	AX-TRAY-MOD-20
X-2 Tray Empty	–	–	AX-TRAY-2-E
FP-40 40 mm Single Fiber Slim Protection Sleeve	–	–	S018262
FP-60 60 mm Single Fiber Slim Protection Sleeve	–	–	S018263

* 576 fibers per tray with mass fusion double-stacking (3456 total closure capacity) only recommended for 200 µm type rollable ribbon. For 250 µm, cut capacity in half with single-stacking.

** When using AFL's Slim Protection Sleeves

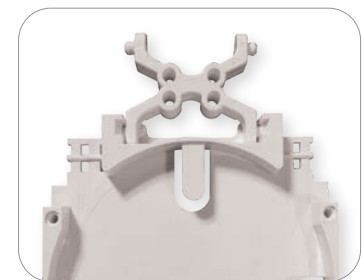
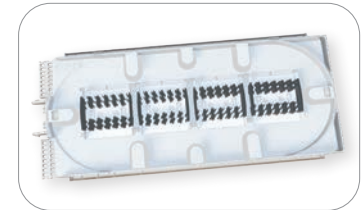

Dimensions

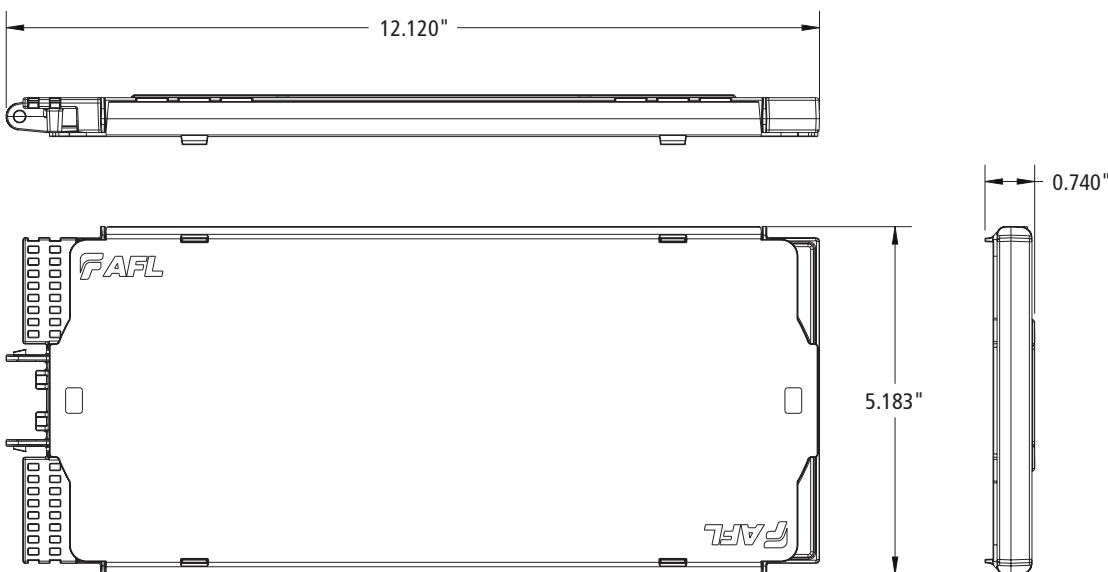

Apex® X-2 Sealed Splice Closure

Installation Kits and Accessories

The AFL Apex closure line has a variety of installation accessories kits to fit many applications. Additional accessories may be available. Contact AFL.



CAU Kit



Ring Clamp Replacement Kit



O-Ring Grease Kit



Wedge Replacement Kit

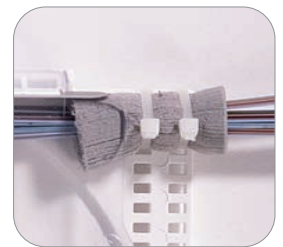

Foam Retention

Ordering Information — Replacement Kits

DESCRIPTION	AFL NO.
REPLACEMENT KITS	
X-2 and X-2S Single Cable Strain Relief/Cable Attachment Unit (CAU) Kit	AX-KIT-CBLSTRN
X-2 and X-2S Dome to Base O-Ring Replacement Kit	AX-KIT-ORING-2
Apex O-Ring Grease, Pack of 10	AX-KIT-GREASE-10
X-2 and X-2S Dome to Base Locking Ring Clamp Replacement Kit	AX-KIT-CLAMP-2
X-2 and X-2S Wedge Replacement Kit	AX-KIT-WEDGE-2
X-2 and X-2S Inner Base Gel Replacement Kit	AX-KIT-GEL-2
X-2 Basket and Yoke Assembly Kit. Can be used in combination with the basket cover.	AX-KIT-BASKET-2
X-2 Inner Basket Kit	AX-KIT-SBASKET-2
X-2 Dome Replacement Kit	AX-KIT-DOME-2
WTC-SWR Bundle Splice Tray Retention Kit - Includes 25 foam grommets for retaining SWR bundles to splice trays	HW000406
Velcro, 75 Foot Length Roll – For securing SWR bundles in the slack basket	FC001759



Apex Aerial Hanger Bracket



Apex Pole/Wall Mount



Adjustable Aerial Hanger Bracket



X-2 and X-2S Installation Stand



Universal Installation Stand

Ordering Information — Accessories

DESCRIPTION	AFL NO.
ACCESSORIES	
Aerial strand mount hanger kit	AX-KIT-AERIAL-1
Pole/wall mount kit	AX-BR30
Adjustable Aerial Strand Mount Hanger kit	AX-KIT-AERIAL-ADJ
ADSS Aerial hanger brackets	AX-KIT-AERIAL-ADSS
Multi-Drop Cable Entry Kit (fits up to 4 cables 0.20" to 0.39" in diameter or flat drop cable)	AX-KIT-DROP-4
X-2 and X-2S Installation Stand	FC104649
Apex Universal Installation Stand	AX-KIT-U-STAND

Apex® X-2 Sealed Splice Closure

Installation Accessories (cont.)



Mesh Transition Tubing

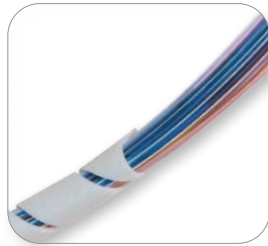

Silicone Spiral Wrap



AFRS Kit 1



AFRS Kit 2

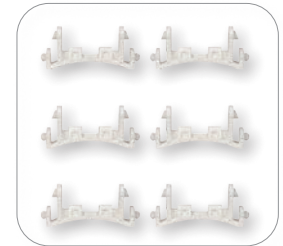

A-B Tray Adapter Kit



SC Bulkhead Adapter Kit

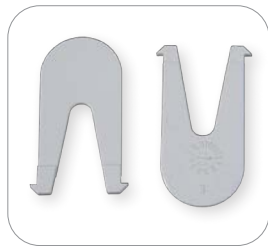

Replacement Slack Storage Basket Tabs

Ordering Information — Accessories (cont.)

DESCRIPTION	AFL NO.
ACCESSORIES	
Apex Cable Bonding Kit (Bonds armored cable sheath to ground) – Pack of 10	AX-KIT-GROUND-10
Apex Internal Multiple Ground Bonding Kit	AX-KIT-GNDLD-5
1/4" Colored Mesh Transition Tubing, 250' Spool (*Replace "XX" with color per TIA-598 color code - BL, OR, GR, BR, SL, WH, RD, BK, YL, VI, RS or AQ)	AX-KIT-TUBE-014-XX*
Silicone Spiral Wrap, 5.5 Foot Length	FC001657
Apex Advanced Fiber Retention System (AFRS) Kit 1 – Used for Ribbon Cable (Flat Matrix, SWR, Tubed, Central Core). Kit includes: Mesh Basket Adapter (2 ea.), Mesh Housing (2 ea.), Mesh Insert (24 ea.), V-Clips (12 ea.), and Clean Cut Gray Mesh (13 ft.).	AX-KIT-AFRSRBN
Apex AFRS Kit 2 – Used for Loose Tube Cable. Kit includes: V-Clip (24 ea.) and Retention Pads (6 sheets of 8 pads)	AX-KIT-AFRSLT
Apex AFRS Kit 3 – V-Clip bulk kit. Includes: V-Clips (120 ea.) and Mesh Inserts (120 ea.)	AX-KIT-AFRSVC-120
Apex AFRS Kit 4 – Mesh bulk kit. Includes: Clean Cut Gray Mesh (100 ft.)	AX-KIT-AFRSMESH-100FT
Apex AFRS Kit 5 – Mesh Housing bulk kit. Includes: Mesh Basket Adapter (10 ea.) and Mesh Housing (10 ea.)	AX-KIT-AFRSAH-10
Apex AFRS Kit 6 – Mesh Basket Adapter bulk kit. Includes: Mesh Basket Adapter (10 ea.)	AX-KIT-AFRSA-10
Apex Restoration Kit, 1000' of 144F Non-Armored Wrapping Tube Cable (Apex X-2S is in Restoration Kit)	AX-2S-B-L-4-4-X-1R1000F
Apex A-B Tray Adapter Kit, 1 Kit of 6 pieces	AX-ADPTR-ABTRAY-6
Apex A-B Tray Adapter Kit, 10 Kits of 6 pieces	AX-ADPTR-ABTRAY-60
Apex Bulkhead Kit with Plate SC/APC Adapters, 1 kit	AX-TRAY-ASC
Apex Bulkhead Kit with Plate with SC/UPC Adapters, 1 kit	AX-TRAY-USC
Apex Bulkhead Kit with Plate SC/APC Adapters, 6 pc kit	AX-TRAY-ASC-6
Apex Bulkhead Kit with Plate SC/UPC Adapters, 6 pc kit	AX-TRAY-USC-6
Apex Replacement Slack Storage Basket Tabs – Pack of 25	AX-KIT-BTAB-25

Apex® X-2 Sealed Splice Closure

Splitter Splice Trays

Passive optical splitters, or PLCs (Planar Lightwave Circuits), can be provided preinstalled into the Apex X-2 splice tray. PLCs can either be installed and splice within the same tray, or provided with a separate dedicated tray for splicing, with fibers routed between trays using protective tubing. A third option provides one additional tray to separate input and output fiber splicing.

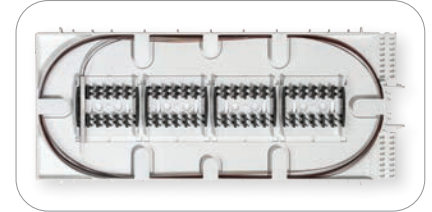

Ordering Information

DESCRIPTION	SPLIT RATIO	AFL NO.
SPLITTER MODULES FOR SPLICE TRAYS		
X-2 Tray with Four Splice Modules, (1) 1x2 PLC Splitter	1x2	AX-TRAY-2-12-1
X-2 Tray with Four Splice Modules, (1) 1x4 PLC Splitter	1x4	AX-TRAY-2-14-1
X-2 Tray with Four Splice Modules, (1) 1x8 PLC Splitter	1x8	AX-TRAY-2-18-1
X-2 Tray with Four Splice Modules, (1) 1x16 PLC Splitter	1x16	AX-TRAY-2-116-1
X-2 Tray with Four Splice Modules, (1) 1x32 PLC Splitter	1x32	AX-TRAY-2-132-1
X-2 Tray with (1) 1x2 PLC Splitter and Separate Splicing Tray with Four Splice Modules	1x2	AX-TRAY-2-12-2
X-2 Tray with (1) 1x4 PLC Splitter and Separate Splicing Tray with Four Splice Modules	1x4	AX-TRAY-2-14-2
X-2 Tray with (1) 1x8 PLC Splitter and Separate Splicing Tray with Four Splice Modules	1x8	AX-TRAY-2-18-2
X-2 Tray with (1) 1x16 PLC Splitter and Separate Splicing Tray with Four Splice Modules	1x16	AX-TRAY-2-116-2
X-2 Tray with (1) 1x32 PLC Splitter and Separate Splicing Tray with Four Splice Modules	1x32	AX-TRAY-2-132-2
X-2 Tray with (1) 1x2 PLC Splitter and 2 Separate Splicing Trays with Four Splice Modules each	1x2	AX-TRAY-2-12-3
X-2 Tray with (1) 1x4 PLC Splitter and 2 Separate Splicing Trays with Four Splice Modules each	1x4	AX-TRAY-2-14-3
X-2 Tray with (1) 1x8 PLC Splitter and 2 Separate Splicing Trays with Four Splice Modules each	1x8	AX-TRAY-2-18-3
X-2 Tray with (1) 1x16 PLC Splitter and 2 Separate Splicing Trays with Four Splice Modules each	1x16	AX-TRAY-2-116-3
X-2 Tray with (1) 1x32 PLC Splitter and 2 Separate Splicing Trays with Four Splice Modules each	1x32	AX-TRAY-2-132-3



Apex® X-2S Sealed Splice Closure

The Apex X-2S is a sealed splice closure designed for protecting optical fiber splices in both above- or below-grade applications in a butt configuration. The Apex X-2S is capable of up to 288 single fusion, 576 mass fusion with standard ribbon, or 1728 (200 μm, 864 max for 250 μm) mass fusion with “rollable ribbon” fiber types such as AFL’s SpiderWeb Ribbon® (SWR®). Cables are sealed by a unique wedge system spaced evenly around the circumference of the closure’s base. Each cable seal is opened by a press-to-release lever and sealing is completed by actuating a single screw for each cable. Each cable is sealed individually, ensuring original craftsmanship when cables may be added at a later date. Up to 6 splice trays are attached and hinge off a central organizer. A plastic slack storage basket resides underneath the trays with ample tie down points for managing tube and fiber slack.

Features

- Individual cable sealing ports with tool-less release mechanism and gel sealing
- Hinging, lockable splice trays
- Plastic slack storage basket with convenient multiple tie-down points with Velcro or tie wraps
- Six cable ports with up to six ground lugs
- Capable of up to 16 drop cables with an expressed distribution cable using multi-drop entry kits
- Splice trays with universal splice modules capable of holding single fusion, mass fusion and mechanical splices as well as other devices such as passive optical splitters
- Dome-to-base O-ring seal retained into dome to prevent loss or damage, but is still replaceable if necessary

Specifications

PARAMETER	VALUE
Dimensions – L x D, in (cm)	20.0 x 12.0 (51 x 30)
Weight, No Trays – lb (kg)	22 (10)
Splice Capacity – Single, Mass (SWR), Mass (Standard)	288, 1728, 576
Splice Tray Capacity	6
Cable Diameter, Single Port, in (mm)	0.40" – 1.10" (10.0 - 28.0)
Cable Diameter, Multi-Drop Kit, in (mm)	0.20" – 0.39" (5.0 - 9.9) or flat drop
Application	Direct Bury, Handhole, Aerial, Pole/Wall
Testing	Test to and Passed GR-771-CORE 20 ft. Waterhead test
Temperature Operating	-40°F to 149°F -40°C to 65°C

Apex® X-2S Sealed Splice Closure

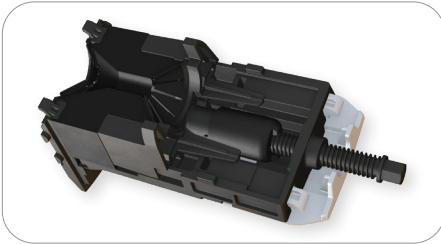

Gel Sealing

Individual wedges located evenly around the circumference of the base are removed with the press of a button. When cables are in place and ready to be sealed, the gel is compressed by a single screw, decreasing installation time. Individual port seals ensure cables never become unsealed when adding new cables at a later date.

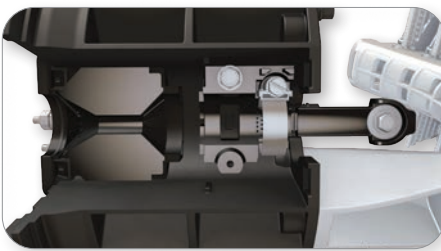

Cable Entry Ports and Strain Relief

The cable entry ports surrounding the circumference of the base accept single cables from 0.4" to 1.1" in diameter. These ports can be expanded through the use of optional drop cable entry kits, allowing up to 4 flat drops or cables from 0.2" to 0.39" to use a single port. Additionally, each port has the capability to be paired with its own grounding lug if necessary. Closures can be configured with enough strain relief kits for 0 to 6 cables from the factory. For closures with less than 6, additional cables can be added through the use of additional cable strain relief kits sold separately.



Slack Storage

A molded slack storage basket allows for use of the entire cross section of the closure to maximize storage.

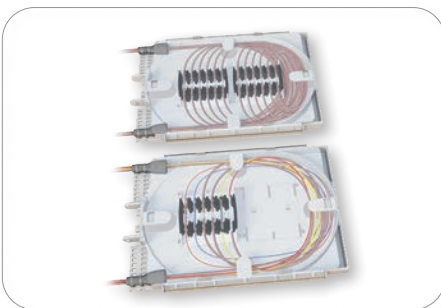

Splice Trays with Modular Splice Holders

Splice trays are organized in a hinging array that automatically lock when tilted to the upward position for easy access to the splice trays and slack storage below. The universal splice module holds up to 24 single fusion, 6 mass fusion or 12 mass fusion double-stacked when using SWR, or 6 mechanical splices as well as devices such as PLC splitters and OADM devices. This eliminates the need for specifying and stocking multiple splice trays for multiple applications.

Ordering Information

AX	2S	B	L	0	2	6	X
APEX CLOSURES	CLOSURE SIZE 2S = X-2S Size	BASKET TYPE B = X-2S Sized Basket	TRAY TYPE X = No preinstalled tray L = X-2S Tray Loaded with splice modules	NUMBER OF TRAYS 0 1 2 3 4 5 6	CABLE STRAIN RELIEF HARDWARE KITS 0 1 2 3 4 5 6	NUMBER OF GROUND LUGS 0 1 2 3 4 5 6	INNER BASKET X = No Inner Basket

Apex® X-2S Sealed Splice Closure

Splice Trays and Splice Modules

Apex X-2S closures utilize X-2S size splice trays. Trays can be ordered fully loaded or half loaded with splice modules. For "rollable" type ribbon such as AFL's SpiderWeb Ribbon®, trays can be fully loaded for 24 mass splices, or 288 fibers per tray. For standard ribbon, AFL recommends half loaded for 6 mass splices single-stacked, or 72 fibers. Adapter kits available to install up to four FOSC® A optical trays.

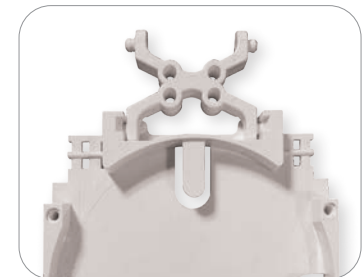
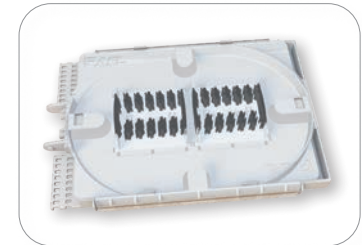

Ordering Information

DESCRIPTION	TRAY CAPACITY		AFL NO.
	SINGLE	MASS	
X-2S Tray Loaded with One Splice Module	24**	72	AX-TRAY-2S-1
X-2S Tray Fully Loaded with Two Splice Modules (288 fibers per tray only recommended for rollable ribbon, e.g. AFL SWR)	48**	288	AX-TRAY-2S-2
Additional splice module (18 single fusion triple stacked, 12 mass fusion double stacked, 6 mechanical) – Pack of 20	-	-	AX-TRAY-MOD-20
X-2S Tray Empty	-	-	AX-TRAY-2S-E
FP-40 40 mm Single Fiber Slim Protection Sleeve	-	-	S018262
FP-60 60 mm Single Fiber Slim Protection Sleeve	-	-	S018263

* 288 fibers per tray with mass fusion double-stacking (1728 total closure capacity) only recommended for 200 μm type rollable ribbon. For 250 μm, cut capacity in half with single-stacking.

** When using AFL's Slim Protection Sleeves

Dimensions

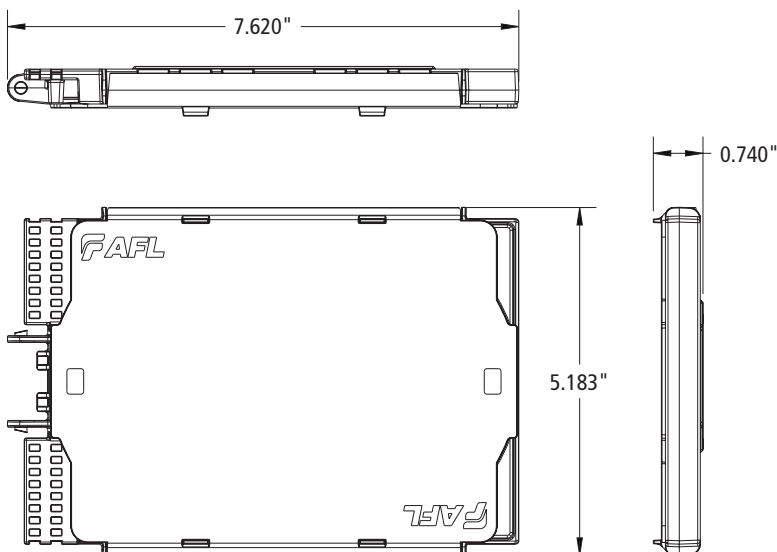

Apex® X-2S Sealed Splice Closure

Installation Kits and Accessories

The AFL Apex closure line has a variety of installation accessories kits to fit many applications. Additional accessories may be available. Contact AFL.



CAU Kit



Ring Clamp Replacement Kit



O-Ring Grease Kit



Wedge Replacement Kit

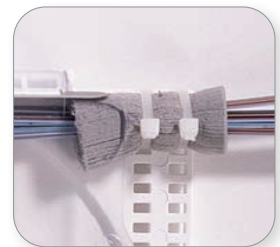

Foam Retention

Ordering Information — Replacement Kits

DESCRIPTION	AFL NO.
REPLACEMENT KITS	
X-2 and X-2S Single Cable Strain Relief/Cable Attachment Unit (CAU) Kit	AX-KIT-CBLSTRN
X-2 and X-2S Dome to Base O-Ring Replacement Kit	AX-KIT-ORING-2
Apex O-Ring Grease, Pack of 10	AX-KIT-GREASE-10
X-2 and X-2S Dome to Base Locking Ring Clamp Replacement Kit	AX-KIT-CLAMP-2
X-2 and X-2S Wedge Replacement Kit	AX-KIT-WEDGE-2
X-2 and X-2S Inner Base Gel Replacement Kit	AX-KIT-GEL-2
X-2S Basket and Yoke Assembly Kit. Can be used in combination with the basket cover.	AX-KIT-BASKET-2S
X-2S Dome Replacement Kit	AX-KIT-DOME-2S
WTC-SWR Bundle Splice Tray Retention Kit - Includes 25 foam grommets for retaining SWR bundles to splice trays	HW000406
Velcro, 75 Foot Length Roll – For securing SWR bundles in the slack basket	FC001759



Apex Aerial Hanger Bracket



Apex Pole/Wall Mount



Adjustable Aerial Hanger Bracket



X-2 and X-2S Installation Stand



Universal Installation Stand

Ordering Information — Accessories

DESCRIPTION	AFL NO.
ACCESSORIES	
Aerial strand mount hanger kit	AX-KIT-AERIAL-1
Pole/wall mount kit	AX-BR30
Adjustable Aerial Strand Mount Hanger kit	AX-KIT-AERIAL-ADJ
ADSS Aerial hanger brackets	AX-KIT-AERIAL-ADSS
Multi-Drop Cable Entry Kit (fits up to 4 cables 0.20" to 0.39" in diameter or flat drop cable)	AX-KIT-DROP-4
X-2 and X-2S Installation Stand	FC104649
Apex Universal Installation Stand	AX-KIT-U-STAND

Apex® X-2S Sealed Splice Closure

Installation Accessories (cont.)



Mesh Transition Tubing

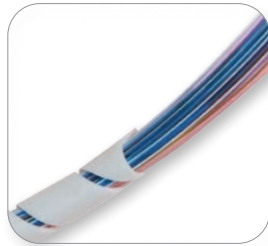

Silicone Spiral Wrap



AFRS Kit 1

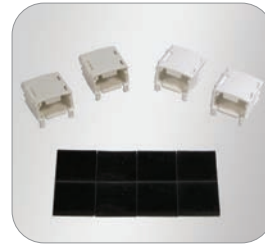

AFRS Kit 2



A-B Tray Adapter Kit



SC Bulkhead Adapter Kit

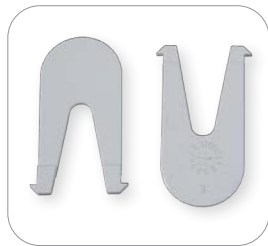

Replacement Slack Storage Basket Tabs

Ordering Information — Accessories (cont.)

DESCRIPTION	AFL NO.
ACCESSORIES	
1/4" Colored Mesh Transition Tubing, 250' Spool (*Replace "XX" with color per TIA-598 color code - BL, OR, GR, BR, SL, WH, RD, BK, YL, VI, RS or AQ)	AX-KIT-TUBE-014-XX*
Silicone Spiral Wrap, 5.5 Foot Length	FC001657
Apex Cable Bonding Kit (Bonds armored cable sheath to ground) – Pack of 10	AX-KIT-GROUND-10
Apex Internal Multiple Ground Bonding Kit	AX-KIT-GNDLD-5
Apex Advanced Fiber Retention System (AFRS) Kit 1 – Used for Ribbon Cable (Flat Matrix, SWR, Tubed, Central Core). Kit includes: Mesh Basket Adapter (2 ea.), Mesh Housing (2 ea.), Mesh Insert (24 ea.), V-Clips (12 ea.), and Clean Cut Gray Mesh (13 ft.).	AX-KIT-AFRSRBN
Apex AFRS Kit 2 – Used for Loose Tube Cable. Kit includes: V-Clip (24 ea.) and Retention Pads (6 sheets of 8 pads)	AX-KIT-AFRSLT
Apex AFRS Kit 3 – V-Clip bulk kit. Includes: V-Clips (120 ea.) and Mesh Inserts (120 ea.)	AX-KIT-AFRSVC-120
Apex AFRS Kit 4 – Mesh bulk kit. Includes: Clean Cut Gray Mesh (100 ft.)	AX-KIT-AFRSMESH-100FT
Apex AFRS Kit 5 – Mesh Housing bulk kit. Includes: Mesh Basket Adapter (10 ea.) and Mesh Housing (10 ea.)	AX-KIT-AFRSAH-10
Apex AFRS Kit 6 – Mesh Basket Adapter bulk kit. Includes: Mesh Basket Adapter (10 ea.)	AX-KIT-AFRSA-10
Apex Restoration Kit, 1000' of 144F Non-Armored Wrapping Tube Cable (Apex X-2S is in Restoration Kit)	AX-2S-B-L-4-4-4-X-1R1000F
Apex A-B Tray Adapter Kit, 1 Kit of 6 pieces	AX-ADPTR-ABTRAY-6
Apex A-B Tray Adapter Kit, 10 Kits of 6 pieces	AX-ADPTR-ABTRAY-60
Apex Bulkhead Kit with Plate SC/APC Adapters, 1 kit	AX-TRAY-ASC
Apex Bulkhead Kit with Plate with SC/UPC Adapters, 1 kit	AX-TRAY-USC
Apex Bulkhead Kit with Plate SC/APC Adapters, 6 pc kit	AX-TRAY-ASC-6
Apex Bulkhead Kit with Plate SC/UPC Adapters, 6 pc kit	AX-TRAY-USC-6
Apex Replacement Slack Storage Basket Tabs – Pack of 25	AX-KIT-BTAB-25

Apex® X-2S Sealed Splice Closure

Splitter Splice Trays

Passive optical splitters, or PLCs (Planar Lightwave Circuits), can be provided preinstalled into the Apex X-2S splice tray. PLCs can either be installed and spliced within the same tray, or provided with a separate dedicated tray for splicing, with fibers routed between trays using protective tubing. A third option provides one additional tray to separate input and output fiber splicing.

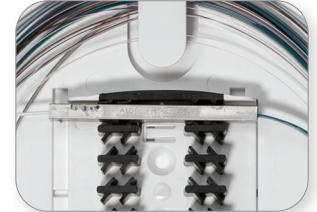
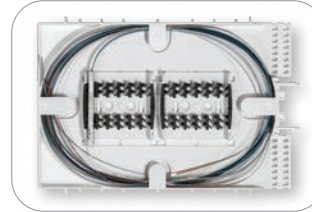

Ordering Information

DESCRIPTION	SPLIT RATIO	AFL NO.
SPLITTER MODULES FOR SPLICE TRAYS		
X-2S Tray with Four Splice Modules, (1) 1x2 PLC Splitter	1x2	AX-TRAY-2S-12-1
X-2S Tray with Two Splice Modules, (1) 1x4 PLC Splitter	1x4	AX-TRAY-2S-14-1
X-2S Tray with Two Splice Modules, (1) 1x8 PLC Splitter	1x8	AX-TRAY-2S-18-1
X-2S Tray with Two Splice Modules, (1) 1x16 PLC Splitter	1x16	AX-TRAY-2S-116-1
X-2S Tray with Two Splice Modules, (1) 1x32 PLC Splitter	1x32	AX-TRAY-2S-132-1
X-2S Tray with (1) 1x2 PLC Splitter and Separate Splicing Tray with Two Splice Modules	1x2	AX-TRAY-2S-12-2
X-2S Tray with (1) 1x4 PLC Splitter and Separate Splicing Tray with Two Splice Modules	1x4	AX-TRAY-2S-14-2
X-2S Tray with (1) 1x8 PLC Splitter and Separate Splicing Tray with Two Splice Modules	1x8	AX-TRAY-2S-18-2
X-2S Tray with (1) 1x16 PLC Splitter and Separate Splicing Tray with Two Splice Modules	1x16	AX-TRAY-2S-116-2
X-2S Tray with (1) 1x32 PLC Splitter and Separate Splicing Tray with Two Splice Modules	1x32	AX-TRAY-2S-132-2
X-2S Tray with (1) 1x2 PLC Splitter and 2 Separate Splicing Trays with Two Splice Modules each	1x2	AX-TRAY-2S-12-3
X-2S Tray with (1) 1x4 PLC Splitter and 2 Separate Splicing Trays with Two Splice Modules each	1x4	AX-TRAY-2S-14-3
X-2S Tray with (1) 1x8 PLC Splitter and 2 Separate Splicing Trays with Two Splice Modules each	1x8	AX-TRAY-2S-18-3
X-2S Tray with (1) 1x16 PLC Splitter and 2 Separate Splicing Trays with Two Splice Modules each	1x16	AX-TRAY-2S-116-3
X-2S Tray with (1) 1x32 PLC Splitter and 2 Separate Splicing Trays with Two Splice Modules each	1x32	AX-TRAY-2S-132-3



Expandable to support various cable diameters



Ease of installation (no tapes, washers, or glue)



Multiple layers of sealing protection

LightGuard® Peel and Seal Grommet Systems for Sealed Fiber Optic Closures

AFL's cable sealing grommet technology for the LightGuard (LG) Sealed Fiber Optic Closures improves sealing technology utilizing MULTICENTRIC® Grommets that do away with time-consuming tasks such as installing washers and messy sealing tapes for cable entry. MULTICENTRIC Grommets are designed to accept a wide range of cable diameters, eliminating the need to stock a variety of diameter-specific grommet kits.

Conversion kits for old LG-100, LG-200, and LG-300 closures allows for "Peel and Seal" grommet technology to be used without changing out the existing closure.

Features

- All Peel and Seal Grommet Systems support loose tube, core tube, dielectric and armored cable designs
- Installation and re-entry using common hand tools
- Accepts a wide range of cable diameters
- Fast and easy to install
- Fits existing AFL LightGuard sealed closures
- Fully sealed to protect fiber and splices ensuring longevity
- Full conversion kits and dual cable entry port kits



Single



Dual



Quad

Ordering information

SEALED CLOSURE FULL CONVERSION KITS (SINGLE AXIS CABLE ENTRY)

DESCRIPTION	AFL NO.
3 Port Drop Grommet (LG-150/250)	FC000655
Dual Express Grommets for LG-350	FC000337
Quad Express Grommets for LG-350	FC000421
Single Cable Grommet Kit, Drop Port	FC000628
4 Port Drop Grommet (LG-350 / LG-350-AC)	FC000422
LG-350 Express Single Cable Grommet Kit	FC000726
LG-350 Drop Single Cable Grommet Kit	FC000727

Qualifications

GOVERNING BODY	STANDARD CODE
Telcordia	GR-771
Rural Utilities Service (RUS)	515

Contact AFL for further details.

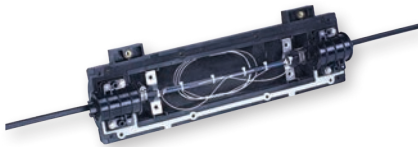
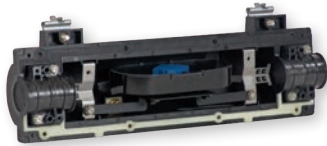

In-line Repair Closure (IRC) for repair of flat or round drop cables

Features

- Accommodates cables to 0.70" O.D for splicing and grounding/bonding
- Incorporates the Peel and Seal Grommet System, fully sealing the closure
- Includes removable, integral central splicing module and individual cable retention clamps
- Requires only a common can wrench for installation

LightGuard® 55 Sealed Fiber Optic Splice Closure

Designed with versatility in mind, the LightGuard (LG) 55 sealed closure from AFL offers a variety of solutions including repair and distribution splicing, grounding for Fiber-in-the-Loop applications, and for use as an isolation gap with armored cables. This closure accepts stranded loose tube or ribbon fiber cables in either armored or dielectric configurations and can be utilized in a butt or in-line configuration.

The LG-55 closure incorporates a unique cable clamp design sealing the cable, allowing both of the cover halves to be removed without disturbing the contents. In addition, AFL's Peel & Seal Grommet System™ is incorporated to ensure a tight fit on various cable diameters, fully sealing the closure and protecting the fiber while eliminating cumbersome tape and washers—making installation fast and easy.

Specifications

PARAMETER	VALUE
Splice Capacity (Max.)—Single, Mass, Mechanical	24, n/a, 24
Number of Splice Trays (Max.)—Single, Mass, Mechanical*	1, n/a, 1
Cable Entrance Configuration	Butt or In-line
Cable Sizes (Min. O.D. - Max. O.D.) Included Grommets Single in. (mm) Double Express Port Only in. (mm)	(2) Express Ports 0.40" - 0.70" (10.0 - 25.4) 0.26" - 0.44" (6.6 - 11.2)
Additional Grommets Quad Express Port Only in. (mm)	0.26" - 0.38" (6.6 - 9.7)
Dimensions—(L x D) in. (mm)	14.0" x 4.0" (343.0 x 101.6)
Weight—lbs. (kg)	3.0 (1.36)

Ordering Information

DESCRIPTION	MODEL NO.	AFL NO.
LG-55 FC000034-PS Fiber Optic Splice Closure—Stores up to 32 single fusion, includes 2 single cable grommets and 1 dual cable grommet kit for sealing/retention and 2 ground terminals. Splice tray and hanger brackets included. Not included: Cable Grounding Kits	LG55-U-1	FC000034-PS
LL-2425 Single Splice Tray—Stores (32) single fusion splices. Maximum of 1 trays in the LG55. Tray Included.	LL-2425	FC000053
LG-350 Single Grommet Kit (Min. 0.40" - Max. 1.00") For use in LG-55 on Express Port side.	LG-350 Exp Single Kit	FC000726
LG-350 Dual Grommet Kit (Min. 0.26" - Max. 0.44") For use in LG-55 on Express Port side.	LG-350 Exp Dual Kit	FC000337
LG-350 Quad Grommet Kit (Min. 0.26" - Max. 0.38") For use in LG-55 on Express Port side.	LG-350 Exp Quad Kit	FC000421
LG-55 Grommet Kit (1) 3 flat drop grommet (flat drop 0.31" or round cable up to 0.25") and (1) dual grommet (Min. 0.26" - Max. 0.44").	LG-55 Drop Kit	FC000807
Cable Grounding Kit (pack of 5)—Clamp-On Ground Cable Only	CGK-5	FC001091
*Mechanical Splice Kit. Includes 10 pieces of VHB tape. Used in all splice trays. Each piece holds 12 splices.	VHB Tape	FA000089

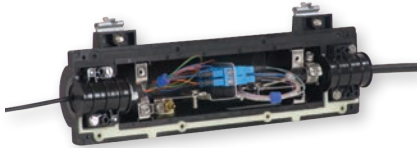

LightGuard® 55-SC Sealed Fiber Optic Splice Closure

AFL's LightGuard (LG) 55-SC sealed closure retains all the features of the LG-55, but includes a unique patching system that utilizes pre-terminated SC fiber assemblies or field-installable connectors such as the FASTConnect® SC.

An innovative solution that can be used to facilitate a link between traffic control cabinets and entrance cables, the LG-55-SC closure allows for rapid restoration and minimal damage to a fiber optic cable should an impact disable the cabinet. A breakable tie wrap secures the pre-connectorized cable to one side of the closure (traffic control cabinet), while the main entrance cable is secured with a more rugged cable clamp, allowing the system to separate during a damaging impact.

Features

- Durable cover assembly that provides protection for all internal components and acts as an interface/anchor to the cable clamps
- Unique cable clamp seal to anchor the cable to the cover assembly
- Movable sheath retention bracket keeps cable bends at a minimum
- Accommodates up to four SC/UPC connectors
- Utilizes AFL's Peel & Seal Grommet System™, ensuring a tight fit on various cable diameters while eliminating cumbersome tape and washers
- Requires only a common can wrench for installation

Specifications

PARAMETER	VALUE
Cable Sizes (Min. O.D. - Max. O.D.)	0.4" - 0.7"
Maximum Cable Entry	2 ports (one each end)
Dimensions - (L x D) in. (mm)	14" x 4" (356.0 mm x 1022.0 mm)

Ordering Information

DESCRIPTION	MODEL NO.	AFL NO.
The LG-55-SC allows for 4 SC connections to be installed. A FASTConnect or FUSEConnect, field installable connectors would be used for the connections. The field side cable is held with a tie-wrap while the signal side is secured to the closure with a hose clamp. This allows for a break-out should a vehicle make contact with a traffic box leaving the signal side cable intact.	LG-55-SC	FC000481-PS
Dual Cable Entry Port Kit – Allows two cables to enter closure from each cable port.	Dual Cable Entry Port Kit	FC000062
Quad Cable Entry Port Kits – Allows 4 cables to enter closure from each cable port	Quad Cable Entry Port Kit	FC000421
Cable Grounding Harness Kit – Includes (5) Clamp-On 9.5" long ground wires AWG #6 conductor	CGK-5	FC001091

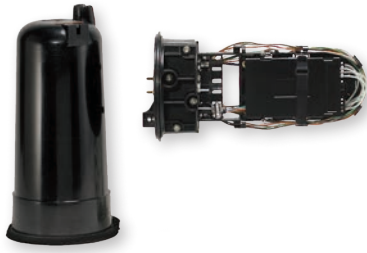

LightGuard® 150 Sealed Fiber Optic Splice Closure

The LightGuard (LG) 150 is a sealed dome closure designed for small count fiber splicing (up to 48 single or 192 mass) in a butt configuration. Utilized in aerial or underground environments where a sealed closure is required, the LG-150 is ideal for express or ring applications and requires only a common can wrench for installation.

Features

- Supports stranded loose tube or ribbon fiber cables in either armored or dielectric configurations
- Installation and re-entry requires only a common can wrench
- Fully sealed to protect fiber and splices ensuring longevity
- Fully kitted with all parts to install five cables
- Designed and tested to Telcordia® GR-771 requirements
- Rural Utilities Service (RUS) Listed

Specifications

PARAMETER	VALUE	
Splice Capacity (Max.)—Single, Mass, Mechanical	48, 192, 48	
Number of Splice Trays (Max.)—Single, Mass, Mechanical*	4, 3, 4	
Cable Entrance Configuration	Butt	
Cables	5	
Cable Sizes (Min. O.D. - Max. O.D.) Included Grommets	(2) Express Ports	(3) Drop Ports
Single in. (mm)	0.26" - 0.62" (6.6 - 15.7)	0.26" - 0.62" (6.6 - 15.7)
Additional Grommets (3) Flat Drop Port Only in. (mm)	n/a	0.19" x 0.34" (4.8 x 8.6) or 0.25" round (6.4)
Dimensions—(L x D) in. (mm)	16.25" x 8.75" (412.75 x 222.3)	
Weight—lbs. (kg)	10.5 (4.76)	

Splice Closure for Fiber Optic Cables

LightGuard® 150 Sealed Fiber Optic Splice Closure

Ordering Information

DESCRIPTION	AFL NO.
LG-150-U-0 Fiber Optic Splice Closure—Stores 48 single fusion or 192 mass fusion, includes (5) cable kits for sealing/retention and (2) ground terminals with removable bond. Not included: Splice Trays, Cable Grounding Kits or Hanger Brackets	FC000001-PS
LL-2450 Single Splice Tray—Stores (12) single fusion splices. Maximum of 4 trays in the LG150	91957-00
LL-4850 Mass Splice Tray—Stores (8) mass fusion splices (96 F). Maximum of 4 trays in the LG-150	91958-00
LL-1248 Universal Splice Tray—Stores (12) single fusion splices or (8) mass fusion splices (96 F), or *Mechanical. Max. of 4 trays in the LG-150	911221-00-00
LG-150/250 Single Grommet Kit (Min. 0.26" - Max. 0.62")	FC000704
LG-150/250 3 Flat Drop Grommet Kit (standard flat drop 0.31" or round cable up to 0.25")	FC000655
Universal Aerial Strand Hanger Kit—For use with LG-150/250/350	FC000006
Extended Offset Strand Hanger Kit—For use with LG-150/250/350	FC000208
Pole or Wall Mount Bracket—For use with LG-150/250/350	LGBR-30
OPGW Dual Cable Bracket Kit for use only when installing closure on OPGW cable—For use with LG-150/250/350	FC000683
OPGW Quad Cable Bracket Kit—For use with LG-150/250	FC000746
1x6 Fiber Router Kit with furcation tubes	FC000070
CGK-5 Cable Grounding Kit (pack of 5)—Clamp-On Ground Cable Only	FC001091
*Mechanical Splice Kit. Includes 10 pieces of VHB tape. Used in all splice trays. Each piece holds 12 splices.	FA000089
O-Ring and Lock Ring Kit—For use with LG-150/250	FC000771

* See Accessory Specifications.
See Splice Tray Specifications.

Qualifications

GOVERNING BODY	STANDARD CODE
Telcordia	GR-771
Rural Utilities Service (RUS)	Listed

Contact AFL for further details.

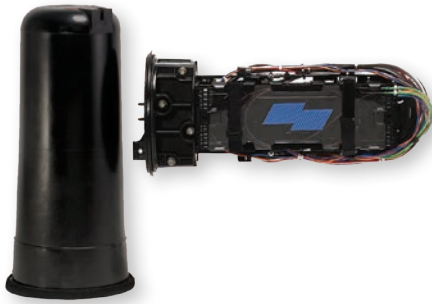

LightGuard® 250 Sealed Fiber Optic Splice Closure

The LightGuard (LG) 250 is a sealed dome closure designed for medium count fiber splicing (up to 144 single or 432 mass) in a butt configuration. Utilized in aerial or underground environments where a sealed closure is required, the LG-250 is ideal for express or ring applications and requires only a common can wrench for installation.

Features

- Supports stranded loose tube or ribbon fiber cables in either armored or dielectric configurations
- Installation and re-entry requires only a common can wrench
- Fully sealed to protect fiber and splices ensuring longevity
- Fully kitted with all parts to install five cables

Specifications

PARAMETER	VALUE	
Splice Capacity (Max.)—Single, Mass, Mechanical	144, 432, 48	
Number of Splice Trays (Max.)—Single, Mass, Mechanical*	4, 3, 4	
Cable Entrance Configuration	Butt	
Cables	5	
Cable Sizes (Min. O.D. - Max. O.D.)		
Included Grommets Single in. (mm)	(2) Express Ports 0.26" - 0.62" (6.6 - 15.7)	(3) Drop Ports 0.26" - 0.62" (6.6 - 15.7)
Additional Grommets (3) Flat Drop Port Only in. (mm)	n/a	0.19" x 0.34" (4.8 x 8.6) or 0.25" round (6.4)
Dimensions—(L x D) in. (mm)	19.0" x 8.75" (482.6 x 222.3)	
Weight—lbs. (kg)	10.5 (4.76)	

continued
→

LightGuard® 250 Sealed Fiber Optic Splice Closure

Ordering Information

DESCRIPTION	AFL NO.
LG-250-U-0 Fiber Optic Splice Closure—Stores 144 single fusion or 432 mass fusion, includes (5) cable kits for sealing/retention and (2) ground terminals with removable bond. Not included: Splice Trays, Cable Grounding Kits or Hanger Brackets	FC000002-PS
LL-2400 Single Splice Tray—Stores (24) single fusion splices. Maximum of 4 trays in the LG-250.	91710-06
LL-2448 Universal Splice Tray—Stores (24) single fusion or (4) mass fusion splices (48 F). Maximum of 3 trays in the LG-250	911289-00-02
LL-4848 Mass Splice Tray—Stores (12) mass fusion splices (144 F). Maximum of 3 trays in the LG-250	911437-00-02
LL-2448-48S Single Splice Tray—Stores (48) single fusion splices. Maximum of 3 trays in the LG-250	FA000045
LG-150/250 Single Grommet Kit (Min. 0.26" - Max. 0.62")	FC000704
LG-150/250 3 Flat Drop Grommet Kit (standard flat drop 0.31" or round cable up to 0.25")	FC000655
Universal Aerial Strand Hanger Kit—For use with LG-150/250/350	FC000006
Extended Offset Strand Hanger Kit—For use with LG-150/250/350	FC000208
PWK Pole or Wall Mount Bracket—For use with LG-150/250/350	LGBR-30
OPGW Dual Cable Bracket Kit—For use with LG-150/250/350	FC000683
OPGW Quad Cable Bracket Kit—For use with LG-150/250	FC000746
1x6 Fiber Router Kit with furcation tubes	FC000070
CGK-5 Cable Grounding Kit (pack of 5)—Clamp-On Ground Cable Only	FC001091
*Mechanical Splice Kit. Includes 10 pieces of VHB tape. Used in all splice trays. Each piece holds 12 splices.	FA000089
O-Ring and Lock Ring Kit—For use with LG-150/2	FC000771

* See Accessory Specifications.
See Splice Tray Specifications.

Qualifications

GOVERNING BODY	STANDARD CODE
Telcordia	GR-771
Rural Utilities Service (RUS)	Listed

Contact AFL for further details.

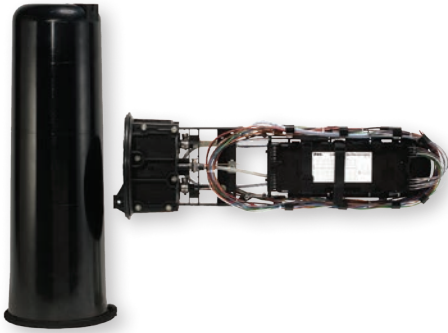

LightGuard® 350 Sealed Fiber Optic Splice Closure

The LightGuard (LG) 350 is a sealed dome closure designed for large count fiber splicing (up to 480 single or 1152 mass) in a butt configuration. Utilized in aerial or underground environments where a sealed closure is required, the LG-350 is ideal for express, ring or long haul applications and requires only a common can wrench for installation.

Features

- Supports stranded loose tube or ribbon fiber cables in either armored or dielectric configurations
- Installation and re-entry requires only a common can wrench
- Fully sealed to protect fiber and splices ensuring longevity
- Fully kitted with all parts to install five cables

Specifications

PARAMETER	VALUE	
Splice Capacity (Max.)—Single, Mass, Mechanical	480, 1152, 108	
Number of Splice Trays (Max.)—Single, Mass, Mechanical*	12, 8, 8	
Cable Entrance Configuration	Butt	
Cables	5 to 11	
Cable Sizes (Min. O.D. - Max. O.D.)	(2) Express Ports	(3) Drop Ports
Included Grommets	0.40" - 1.00"	0.26" - 0.80"
Single in. (mm)	(10.0 - 25.4)	(6.6 - 20.0)
Additional Grommets	0.26" - 0.44"	
Dual Express Port Only in. (mm)	(6.6 - 11.2)	
Quad Express Port Only in. (mm)	0.26" - 0.38"	
	(6.6 - 9.7)	
(4) Flat Drop Port Only in. (mm)		0.19" x 0.34"
		(4.8 x 8.6) or
		0.25" round (6.4)
Dimensions—(L x D) in. (mm)	28.0" x 10.0" (710.0 x 254.0)	
Weight - lbs. (kg)	16 (7.26)	

continued
→

LightGuard® 350 Sealed Fiber Optic Splice Closure

Ordering Information

DESCRIPTION	AFL NO.
LG-350-U-0 Fiber Optic Splice Closure – Stores 480 single fusion or 1152 mass fusion, includes (5) cable kits for sealing/retention and (2) ground terminals with removable bond. Not included: Splice Trays, Cable Grounding Kits or Hanger Brackets	FC000009-PS
LL-2400 Single Splice Tray – Stores (24) single fusion splices. Maximum of 12 trays in the LG-350	91710-06
LL-2448 Universal Splice Tray – Stores (24) single fusion or (4) mass fusion splices (48 F). Maximum of 8 trays in the LG-350	911289-00-02
LL-4848 Mass Splice Tray – Stores (12) mass fusion splices (144 F). Maximum of 8 trays in the LG-350	911437-00-02
LL-2448-48S Single Splice Tray – Stores (48) single fusion splices. Maximum of 8 trays in the LG-350	FA000045
LL-4896 Universal Splice Tray – Stores (96) single fusion splices or (24) mass fusion splices (288 F). Maximum of 5 trays in the LG-350	911676-00-02
LL-4896-R Mass Splice Tray – Stores (24) mass fusion splices (288 F). Maximum of 5 trays in the LG-350	FA000022
LL-4896-L Single Splice Tray – Stores (96) single fusion splices. Maximum of 5 trays in the LG-350	FA000023
LL-7644 Universal Splice Tray – Stores (60) single fusion or (288) mass fusion splices or a combination of both in an easy-to-use, deep splice tray. For use with LG-350SD	FA000044
LL-7060 Splice Tray – Stores (60) single fusion splices in an easy-to-use, deep splice tray – For use in LG-350	FA000042
LL-7144 Splice Tray – Stores (288) mass fusion splices in an easy-to-use, deep splice tray – For use in LG-350	FA000043
LG-350 Single Grommet Kit (Min. 0.40" - Max. 1.00") – For use in LG-350/AC/SD on Express Port side	FC000726
LG-350 Dual Grommet Kit (Min. 0.26" - Max. 0.44") – For use in LG-350/AC/SD on Express Port side	FC000337
LG-350 Quad Grommet Kit (Min. 0.26" - Max. 0.38") – For use in LG-350/AC/SD on Express Port side	FC000421
LG-350 Single Grommet Kit (Min. 0.26" - Max. 0.80") – For use in LG-350/AC/SD on Drop Port side	FC000727
LG-350 Drop 4 Flat Drop Grommet Kit – For use with standard flat drop cable and round cable up to 0.25" O.D.	FC000422
Universal Aerial Strand Hanger Kit – For use with LG-150/250/350	FC000006
Extended Offset Strand Hanger Kit – For use with LG-150/250/350	FC000208
PWK Pole or Wall Mount Bracket – For use with LG-150/250/350	LGBR-30
OPGW Dual Cable Bracket Kit – For use with LG-150/250/350	FC000683
OPGW Quad Cable Bracket Kit for use when installing Sealed Closures – For use with LG-350	FC000747
1x6 Fiber Router Kit with furcation tubes	FC000070
CGK-5 Cable Grounding Kit (pack of 5) – Clamp-On Ground Cable Only	FC001091
*Mechanical Splice Kit. Includes 10 pieces of VHB tape. Used in all splice trays. Each piece holds 12 splices.	FA000089
O-Ring and Lock Ring Kit – For use with LG-350/350AC/SD	FC000775

* See Accessory Specifications. See Splice Tray Specifications.
Micro Duct Grommets available. Please call Customer Service for details.

Qualifications

GOVERNING BODY	STANDARD CODE
Telcordia	GR-771
Rural Utilities Service (RUS)	Listed

Contact AFL for further details.



LightGuard® 350-20-WTC Sealed Fiber Optic Splice Closure

The LightGuard (LG) 350-20-WTC is a sealed dome closure designed for medium count fiber splicing (up to 144 single or 576 mass) in a butt configuration where space may be limited. The LG-350-20-WTC has been designed and optimized for use in conjunction with AFL Wrapping Tube Cable (WTC), with SpiderWeb Ribbon® (SWR®). The WTC-focused design provides a basket for easy slack management. Additionally, WTC SpiderWeb Ribbon bundles can be routed and secured to splice trays without the use of transition tubing (when using AFL's WTC-SWR Bundle Splice Tray Retention Kit), greatly reducing installation time. Transition tubing kits are also available if desired.

Features

- Less than 20" overall length; ideal for small hand-holes
- Optimized for AFL WTC but also supports stranded loose tube or ribbon fiber cables in either armored or dielectric configurations
- Installation and re-entry requires only a common can wrench
- Fully sealed to protect fiber and splices ensuring longevity
- Kitted with all parts to install up to two WTC cables (strength member retention not included – not required for WTC)

Specifications

PARAMETER		VALUE	
Splice Capacity (Max.) – Single, Mass, Mechanical		144, 576, 48	
Number of Splice Trays (Max.) – Single, Mass, Mechanical*		4, 4, 4	
Cable Entrance Configuration		Butt	
Cables		2 to 8 Express with up to 12 Drop	
Cable Sizes (Min. O.D. - Max. O.D.)	Included Grommets	(2) Express Ports	(3) Drop Ports
	Single – in. (mm)	0.40" - 1.00" (10.0 - 25.4)	0.26" - 0.80" (6.6 - 20.0) (Drop Port Entry Kits Not Included)
	(4) Flat Drop Only – in. (mm)		(4 port) 0.26" - 0.80" (6.6 - 20.0)
	Additional Grommets		
	Dual Express Port Only – in. (mm)	0.26" - 0.44" (6.6 - 11.2)	
	Quad Express Port Only – in. (mm)	0.26" - 0.38" (6.6 - 9.7)	
(4) Flat Drop Port Only – in. (mm)			0.19" x 0.34" (4.8 x 8.6) or 0.25" round (6.4)
Dimensions – (L x D) in. (mm)		19.8" x 10.0" (503.0 x 254.0)	
Weight – lbs. (kg)		12.0 (5.44)	

continued
→

LightGuard® 350-20-WTC Sealed Fiber Optic Splice Closure

Ordering Information

DESCRIPTION	MODEL NO.	AFL NO.
LG-350-20-WTC Fiber Optic Splice Closure—Stores 144 single fusion or 576 mass fusion, includes (2) Express cable kits for sealing/retention and (2) ground terminals with removable bond. Does not include: Cable grounding kits, hanger brackets, splice trays or drop port entry kits	LG-350-20-WTC-U	FC001348
LL-4808L-R Universal Splice Tray—Stores (36) single fusion splices or (12) mass fusion splices (144 F). Maximum of 4 trays in the LG-350-20-WTC	LL-4808L-R	FA000037
LL-4808-R Mass Splice Tray—Stores (12) mass fusion splices (144 F). Maximum of 4 trays in the LG-350-20-WTC	LL-4808-R	FA000020
LL-4808-L Single Splice Tray—Stores (36) single fusion splices. Maximum of 4 trays in the LG-350-20-WTC	LL-4808-L	FA000021
LG-350 Single Grommet Kit (Min. 0.40" - Max. 1.00")—For use in LG-55/LG-350/LG-350-AC/SD/WTC on Express Port side	LG-350 Exp Single Kit	FC000726
LG-350 Dual Grommet Kit (Min. 0.26" - Max. 0.44")—For use in LG-55/LG-350/LG-350-AC/SD/WTC on Express Port side	LG-350 Exp Dual Kit	FC000337
LG-350 Quad Grommet Kit (Min. 0.26" - Max. 0.38")—For use in LG-55/LG-350/LG-350-AC/SD/WTC on Express Port side	LG-350 Exp Quad Kit	FC000421
LG-350 Single Grommet Kit (Min. 0.26" - Max. 0.80")—For use in LG-350/LG-350-AC/SD/WTC on Drop Port side	LG-350 Drop Single Kit	FC000727
LG-350 Drop 4 Flat Drop Grommet Kit—For use with standard flat drop cable and round cable up to 0.25" O.D.	LG-350 Drop 4 Flat Kit	FC000422
Universal Aerial Strand Hanger Kit—For use with LG-150/250/350	Universal Hanger	FC000006
Extended Offset Strand Hanger Kit—For use with LG-150/250/350	Extended Offset Hanger	FC000208
Pole or Wall Mount Bracket—For use with LG-150/250/350	PWK	LGBR-30
Cable Grounding Kit (pack of 5)—Clamp-On Ground Cable Only	CGK-5	FC001091
*Mechanical Splice Kit. Includes 10 pieces of VHB tape. Used in all splice trays. Each piece holds 12 splices.	VHB Tape	FA000089
O-Ring and Lock Ring Kit—For use with LG-350/AC/SD/WTC	LG-350 O-Ring Lock Ring Kit	FC000775
Transition Tubing Kit - Includes 25 pieces of 25" long tubes for WTC bundles	Tubing Kit	FC001372
WTC-SWR Bundle Splice Tray Retention Kit - Includes 25 foam grommets for retaining SWR bundles to splice trays	Foam Retention Kit	HW000406

* See Accessory Specifications.
See Splice Tray Specifications.

Qualifications

GOVERNING BODY	STANDARD CODE
Telcordia	GR-771

Contact AFL for further details.



LightGuard® 350-27-WTC Sealed Fiber Optic Splice Closure

The LightGuard (LG) 350-27-WTC is a sealed dome closure designed for large count fiber splicing (up to 180 single or 864 mass) in a butt configuration. The LG-350-27-WTC has been designed and optimized for use in conjunction with AFL Wrapping Tube Cable (WTC), with SpiderWeb Ribbon® (SWR®). The WTC-focused design provides a dedicated channel for fiber bundle routing as well as a basket for easy slack management.

Additionally, WTC SpiderWeb Ribbon bundles may be routed and secured to splice trays without the use of transition tubing, when using AFL's WTC-SWR Bundle Splice Tray Retention Kit, greatly reducing installation time.

Features

- Dedicated SWR Bundle routing channel protects fibers and eliminates the need for time-consuming transition tubes
- Optimized for AFL WTC but also supports stranded loose tube or ribbon fiber cables in either armored or dielectric configurations
- Installation and re-entry requires only a common can wrench
- Fully sealed to protect fiber and splices ensuring longevity
- Kitted with all parts to install up to two WTC cables (strength member retention not included – not required for WTC)

Specifications

PARAMETER		VALUE	
Splice Capacity (Max.) – Single, Mass, Mechanical		180, 864, 36	
Number of Splice Trays (Max.) – Single, Mass, Mechanical*		3, 3, 3	
Cable Entrance Configuration		Butt	
Cables		5 to 11	
Cable Sizes (Min. O.D. - Max. O.D.)	Included Grommets	(2) Express Ports	(3) Drop Ports
	Single – in. (mm)	0.40" - 1.00" (10.0 - 25.4)	0.26" - 0.80" (6.6 - 20.0) (Drop Port Entry Kits Not Included)
	Additional Grommets		
	Dual Express Port Only – in. (mm)	0.26" - 0.44" (6.6 - 11.2)	
	Quad Express Port Only – in. (mm)	0.26" - 0.38" (6.6 - 9.7)	
	(4) Flat Drop Port Only – in. (mm)		0.19" x 0.34" (4.8 x 8.6) or 0.25" round (6.4)
Dimensions – (L x D) in. (mm)		28.0" x 10.0" (710.0 x 254.0)	
Weight – lbs. (kg)		16 (7.26)	

continued



LightGuard® 350-27-WTC Sealed Fiber Optic Splice Closure

Ordering Information

DESCRIPTION	MODEL NO.	AFL NO.
LG-350-27-WTC Fiber Optic Splice Closure—Stores 180 single fusion or 864 mass fusion, includes (2) Express cable kits for sealing/retention and (2) ground terminals with removable bond. Does not include: Cable grounding kits, hanger brackets, splice trays or drop port entry kits	LG-350-27-WTC-U	FC001349
LL-7644 Universal Splice Tray—Stores (60) single fusion splices or (24) mass fusion splices (288F). Maximum of 3 trays in the LG-350-27-WTC	LL-7644	FA000044
LL-7144 Mass Splice Tray—Stores (24) mass fusion splices (288F). Maximum of 3 trays in the LG-350-27-WTC	LL-7144	FA000043
LL-7060 Single Splice Tray—Stores (60) single fusion splices. Maximum of 3 trays in the LG-350-27-WTC	LL-7060	FA000042
LG-350 Single Grommet Kit (Min. 0.40" - Max. 1.00")—For use in LG-55/LG-350/LG-350-AC/SD/WTC on Express Port side	LG-350 Exp Single Kit	FC000726
LG-350 Dual Grommet Kit (Min. 0.26" - Max. 0.44")—For use in LG-55/LG-350/LG-350-AC/SD/WTC on Express Port side	LG-350 Exp Dual Kit	FC000337
LG-350 Quad Grommet Kit (Min. 0.26" - Max. 0.38")—For use in LG-55/LG-350/LG-350-AC/SD/WTC on Express Port side	LG-350 Exp Quad Kit	FC000421
LG-350 Single Grommet Kit (Min. 0.26" - Max. 0.80")—For use in LG-350/LG-350-AC/SD/WTC on Drop Port side	LG-350 Drop Single Kit	FC000727
LG-350 Drop 4 Flat Drop Grommet Kit—For use with standard flat drop cable and round cable up to 0.25" O.D.	LG-350 Drop 4 Flat Kit	FC000422
Universal Aerial Strand Hanger Kit—For use with LG-150/250/350	Universal Hanger	FC000006
Extended Offset Strand Hanger Kit—For use with LG-150/250/350	Extended Offset Hanger	FC000208
Pole or Wall Mount Bracket—For use with LG-150/250/350	PWK	LGBR-30
Cable Grounding Kit (pack of 5)—Clamp-On Ground Cable Only	CGK-5	FC001091
*Mechanical Splice Kit. Includes 10 pieces of VHB tape. Used in all splice trays. Each piece holds 12 splices.	VHB Tape	FA000089
O-Ring and Lock Ring Kit—For use with LG-350/AC/SD/WTC	LG-350 O-Ring Lock Ring Kit	FC000775
Transition Tubing Kit - Includes 25 pieces of 25" long tubes for WTC bundles	Tubing Kit	FC001372
WTC-SWR Bundle Splice Tray Retention Kit - Includes 25 foam grommets for retaining SWR bundles to splice trays	Foam Retention Kit	HW000406
Strength Member Retention Bracket Kit (10 pieces, for use with stranded loose tube or central tube ribbon cables requiring strength member retention)	Strength Member Kit	FC001362

* See Accessory Specifications.
See Splice Tray Specifications.

Qualifications

GOVERNING BODY	STANDARD CODE
Telcordia	GR-771

Contact AFL for further details.

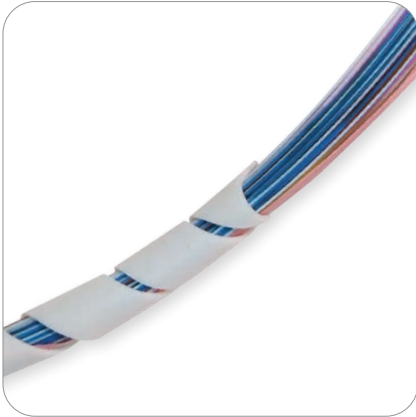

Silicone Spiral Wrap

Silicone spiral wrap can be used to protect SpiderWeb Ribbon® bundles (up to 288 fibers) as well as up to 12 standard ribbons. The silicone spiral wrap can protect expressed fiber slack in various applications as well as act as a transition tube from a slack storage basket to splice trays in various splice closures.

Dimensions

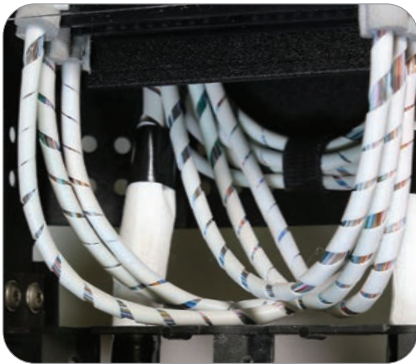
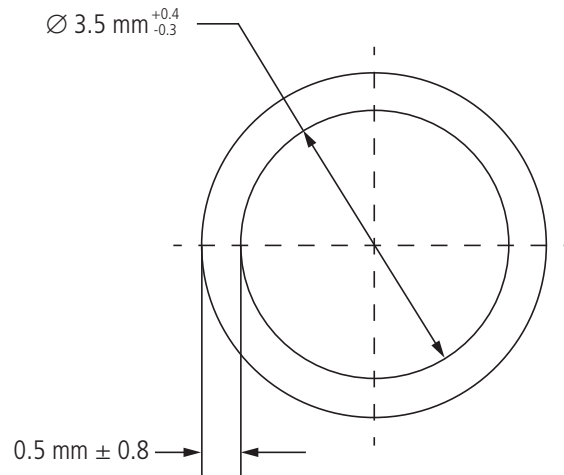

Ordering Information

DESCRIPTION	AFL NO.
Silicone Spiral Wrap, 5.5 Foot Length	FC001657

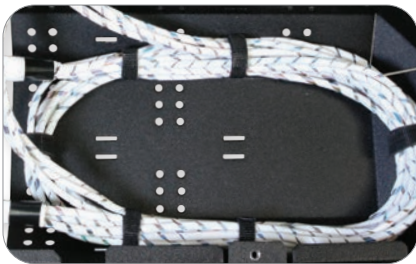



LightGuard® 350-AC Drop Access Sealed Fiber Optic Splice Closure

The LightGuard (LG) 350-AC is a sealed dome closure designed for medium count fiber splicing (up to 144 single or 432 mass) in a butt configuration where space may be limited. Utilized in aerial or underground environments where a sealed closure is required, the LG-350-AC is designed for “drop access” applications providing access for up to 12 drops. The LG-350-AC is ideal for Fiber-to-the-Home installations in small hand-hole application and requires only a common can wrench for installation.

Features

- Less than 20" overall length; ideal for small hand-holes
- Supports stranded loose tube or ribbon fiber cables in either armored or dielectric configurations
- Installation and re-entry requires only a common can wrench
- Fully sealed to protect fiber and splices ensuring longevity
- Fully kitted with all parts to install two cables and up to 12 drops

Specifications

PARAMETER	VALUE	
Splice Capacity (Max.)—Single, Mass, Mechanical	144, 432, 48	
Number of Splice Trays (Max.) - Single , Mass, Mechanical*	4, 3, 4	
Cable Entrance Configuration	Butt	
Cables	2 to 8 Express with up to 12 Drop	
Cable Sizes (Min. O.D. - Max. O.D.)	(2) Express Ports	(3) Drop Ports
Included Grommets	0.40" - 1.00"	(4 port) 0.26" - 0.80"
Single in. (mm)	(10.0 - 25.4)	
(4) Flat Drop Only in. (mm)		(6.6 - 20.0)
Additional Grommets		
Dual Express Port Only in. (mm)	0.26" - 0.44"	
	(6.6 - 11.2)	
Quad Express Port Only in. (mm)	0.26" - 0.38"	
	(6.6 - 9.7)	
(4) Flat Drop Port Only in. (mm)		0.19" x 0.34"
		(4.8 x 8.6) or
		0.25" round (6.4)
Dimensions - (L x D) in. (mm)	19.8" x 10.0" (503.0 x 254.0)	
Weight - lbs. (kg)	12.0 (5.44)	

continued
→

LightGuard® 350-AC Drop Access Sealed Fiber Optic Splice Closure

Ordering Information

DESCRIPTION	AFL NO.
LG-350-AC Fiber Optic Splice Closure—Stores 144 single fusion or 432 mass fusion, includes (2) Express cable kits and (12) Drop cable kits for sealing/retention and (2) ground terminals with removable bond. Included: (1) LL-4808L Splice Tray Not included: Cable Grounding Kits, or Hanger Brackets	FC000412
LL-4808L-R Universal Splice Tray—Stores (36) single fusion splices or (12) mass fusion splices (144 F). Maximum of 4 trays in the LG-350-AC.	FA000037
LL-4808-R Mass Splice Tray—Stores (12) mass fusion splices (144 F). Maximum of 4 trays in the LG-350-AC	FA000020
LL-4808-L Single Splice Tray—Stores (36) single fusion splices. Maximum of 4 trays in the LG-350-AC	FA000021
LG-350 Single Grommet Kit (Min. 0.40" - Max. 1.00")—For use in LG-55/LG-350/LG-350-AC on Express Port side	FC000726
LG-350 Dual Grommet Kit (Min. 0.26" - Max. 0.44")—For use in LG-55/LG-350/LG-350-AC on Express Port side	FC000337
LG-350 Quad Grommet Kit (Min. 0.26" - Max. 0.38")—For use in LG-55/LG-350/LG-350-AC on Express Port side	FC000421
LG-350 Single Grommet Kit (Min. 0.26" - Max. 0.80")—For use in LG-350/AC/SD on Drop Port side	FC000727
LG-350 Drop 4 Flat Drop Grommet Kit—For use with standard flat drop cable and round cable up to 0.25" O.D.	FC000422
Universal Aerial Strand Hanger Kit—For use with LG-150/250/350	FC000006
Extended Offset Strand Hanger Kit—For use with LG-150/250/350	FC000208
PWK Pole or Wall Mount Bracket—For use with LG-150/250/350	LGBR-30
OPGW Dual Cable Bracket Kit—For use with LG-150/250/350	FC000683
1x6 Fiber Router Kit with furcation tubes	FC000070
CGK-5 Cable Grounding Kit (pack of 5)—Clamp-On Ground Cable Only	FC001091
*Mechanical Splice Kit. Includes 10 pieces of VHB tape. Used in all splice trays. Each piece holds 12 splices.	FA000089
LG-350 O-Ring and Lock Ring Kit—For use with LG-350/AC/SD	FC000775

* See Accessory Specifications.
See Splice Tray Specifications.

Qualifications

GOVERNING BODY	STANDARD CODE
Telcordia	GR-771
Rural Utilities Service (RUS)	Listed

Contact AFL for further details.



LightGuard® 350XL Sealed Fiber Optic Splice Closure

The LightGuard (LG) 350XL is a sealed dome closure designed for large count fiber splicing (up to 864 single or 2592 mass) in a butt configuration. Utilized in aerial or underground environments where a sealed closure is required, the LG-350XL is ideal for high fiber count splicing and requires only a common can wrench for installation. A Phillips head screw is used to secure the tray support to the basket.

Features

- Supports stranded loose tube or ribbon fiber cables in either armored or dielectric configurations
- Installation and re-entry requires only a common can wrench
- Fully sealed to protect fiber and splices ensuring longevity
- Fully kitted with all parts to install five cables
- Accommodates up to 7 cables
- Oversized basket allows multiple configurations of slack storage
- O-Ring and Locking Ring for increased protection

Specifications

PARAMETER	VALUE	
Splice Capacity (Max.)—Single, Mass, Mechanical	864, 2592, 288	
Number of Splice Trays (Max.)—Single, Mass, Mechanical*	9, 9, 9	
Cable Entrance Configuration	Butt	
Cables	5 to 7	
Cable Sizes (Min. O.D. - Max. O.D.)	(2) Express Ports	(3) Drop Ports
Included Grommets Single in. (mm)	0.40" - 1.18" (10.0 - 30.0)	0.30" - 1.08" (7.6 - 27.4)
Additional Grommets Dual Exp. Port Only in. (mm)	0.38" - 0.56" (9.7 - 14.2)	
Dimensions - (L x D) in. (mm)	31.0" x 12.00" (788.5 x 305.0)	
Weight - lbs. (kg)	25.0 (11.3)	

continued
→

LightGuard® 350XL Sealed Fiber Optic Splice Closure

Ordering Information

DESCRIPTION	AFL NO.
LG-350XL-U-0 Fiber Optic Splice Closure – Stores 864 single fusion or 2592 mass fusion, includes (5) cable kits for sealing/retention and (2) ground terminals with removable bond. Not included: Splice Trays, Cable Grounding Kits or Hanger Brackets	FC000010-PS
LL-4896 Universal Splice Tray – Stores (96) single fusion splices or (24) mass fusion splices (288 F), *Mechanical. Max. of 9 trays in the LG-350XL	911676-00-02
LL-4896-R Mass Splice Tray – Stores (24) mass fusion splices (288 F). Max. of 9 trays in the LG-350XL	FA000022
LL-4896-L Single Splice Tray – Stores (96) single fusion splices. Max. of 9 trays in the LG-350XL	FA000023
LG-350XL Single Grommet Kit (Min. 0.40" - Max. 1.18") – For use in LG-350XL on Express Port side	FC000870
LG-350XL Dual Grommet Kit (Min. 0.38" - Max. 0.56") – For use in LG-350XL on Express Port side	FC000688
LG-350XL Single Grommet Kit (Min. 0.30" - Max. 1.08") – For use in LG-350XL on Drop Port side	FC000871
LG-350XL Drop 4 Flat Drop Grommet Kit – For use with standard flat drop cable and round cable up to 0.25" O.D.	FC001713
Strand Mount Hanger Bracket – For use with LG-350XL in strand or vault mounting	912215-00-00
1x6 Fiber Router Kit with furcation tubes	FC000070
CGK-5 Cable Grounding Kit (pack of 5) – Clamp-On Ground Cable Only	FC001091
*Mechanical Splice Kit. Includes 10 pieces of VHB tape. Used in all splice trays. Each piece holds 12 splices.	FA000089
O-Ring and Lock Ring Kit – For use with LG-350XL	FC001328
Transition tubing 16.25" long – Used to transport ribbon to the splice trays. (20) per kit	FC001372

* See LL-4896 Splice Tray Specifications.

Qualifications

GOVERNING BODY	STANDARD CODE
Telcordia	GR-771
Rural Utilities Service (RUS)	Listed

Contact AFL for further details.

LightGuard® Sealed Splice Closure Accessories



Dual Express Grommets for LG-350XL

Used on the express side of the LG-350XL closure for installing additional branches. Use the drop ports for the express cable while the express ports may be used to introduce small branch cables. Minimum cable diameter is 0.380" - 0.560".

Ordering Information

DESCRIPTION	AFL NO.
Dual Express Grommets for LG-350XL	FC000688



Dual and Quad Express Grommets for LG-350

Used on the express side of the LG-350 closure for installing additional branches. Use the drop ports for the express cable while the express ports may be used to introduce small branch cables. A 4-drop flat grommet may be used if drops are also required. Cable diameter for dual grommets is 0.26" - 0.44"; for quad, 0.24" - 0.382".



Ordering Information

DESCRIPTION	AFL NO.
Dual Express Grommets for LG-350	FC000337
Quad Express Grommets for LG-350	FC000421



4-Port Flat Drop Grommet Kit for LG-350/LG-350-AC

Used with the LG-350 and LG-350-AC Sealed Closures. Allows for quick addition of drop cables as required. Simply replace the drop port grommets with this grommet kit and install standard flat drop cable or round cable up to 0.25" in diameter.

Ordering Information

DESCRIPTION	AFL NO.
4-Port Flat Drop Grommet Kit for LG-350/LG-350-AC	FC000422



Single Cable and 3-Port Flat Drop Grommet Kit for LG-150/LG-250

Used with the LG-150 and LG-250 Sealed Closures. Allows for quick addition of drop cables as required. Simply replace the drop port grommets with this grommet kit. Both closures will accept standard flat drop cable or round cable up to 0.250" in diameter.

Ordering Information

DESCRIPTION	AFL NO.
Single Cable Grommet Kit for the LG-150/LG-250	FC000704
3-Port Flat Drop Grommet Kit for the LG-150/LG-250	FC000655

continued
→

LightGuard® Sealed Splice Closure Accessories (cont.)



Single Cable Grommet Kits for LG-350-AC and LG-350

Used with the LG-350-AC when a branch cable is required with the drop cables. May also be used for with the LG-350 as replacement grommets. Simply remove the flat drop grommet and replace with the single cable grommets.

Ordering Information

DESCRIPTION	AFL NO.
Single Cable Grommet Kit, Drop Port for LG-350-AC	FC000628
Express Single Cable Grommet Kit for LG-350	FC000726
Drop Single Cable Grommet Kit for LG-350	FC000727



OPGW Cable Bracket for LG-150/LG-250/LG-350

Attaches to the outer grounding studs of the LG-150/LG-250 or LG-350 Sealed Closures. Stainless steel hose clamps secure the OPGW cable to the bracket preventing twisting or movement.

Ordering Information

DESCRIPTION	AFL NO.
OPGW Cable Bracket for the LG-150/LG-250/LG-350 for 2 cables.	FC000683
OPGW Cable Bracket Kit for use when installing Sealed Closures (LG-150/LG-250) to 4 OPGW Cables.	FC000746
OPGW Cable Bracket Kit for use when installing Sealed Closures (LG-350) to 4 OPGW Cables.	FC000747



Pole/Wall Mount Bracket for LG-150/LG-250/LG-350

Used with the LG-150, LG-250, LG-350 and LG-350-AC to secure the closures onto poles or walls in a vertical orientation. Slots on the brackets allow for strapping onto steel or cement poles.

Ordering Information

DESCRIPTION	AFL NO.
Pole/Wall Mount Bracket for LG-150/LG-250/LG-350/LG-350-AC	FC000592



Universal Aerial Bracket and Extended Offset Bracket

Used with the LG-150, LG-250, LG-350 and LG-350-AC for mounting on aerial or messengers.

Ordering Information

DESCRIPTION	AFL NO.
Universal Aerial Bracket for LG-150/LG-250/LG-350/LG-350-AC	FC000006
Extended Offset Bracket	FC000208

continued
→

LightGuard® Sealed Splice Closure Accessories (cont.)



Strand Mount Hanger Bracket for LG-350XL

Used with the LG-350XL.

Ordering Information

DESCRIPTION	AFL NO.
Strand Mount Hanger Bracket – For use with LG-350XL	912215-00-00



Cable Ground Kits

Used with the LG-150, LG-250 and LG-350.

Ordering Information

DESCRIPTION	AFL NO.
Cable Grounding Kit – Includes harness and hose clamp. One kit needed per cable entry. For use with LG-150/250/350.	FC000003
Cable Grounding Harness Kit – Includes (4) 8" ground harnesses constructed of #6 AWG conductor	FC000024
Cable Grounding Kit (pack of 5) – Includes harness and hose clamp. For use with LG-150/250/350.	FC000040



O-Ring Replacement Kits

Used with the LG-150, LG-250, LG-350 and LG-350XL.

Ordering Information

DESCRIPTION	AFL NO.
O-Ring Replacement Kit – For use with LG-150/250	FC000004
O-Ring Replacement Kit – For use with LG-300XL	FC000016
O-Ring Replacement Kit – For use with LG-350.	912231-00-00

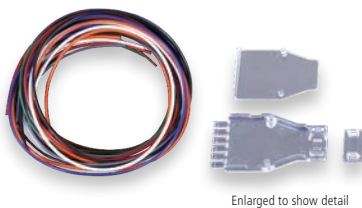

1x6 Cable Router Kit

Used with the LG-150, LG-250, LG-350 and LG-350-AC.

Ordering Information

DESCRIPTION	AFL NO.
1X6 Cable Router Kit	FC000070

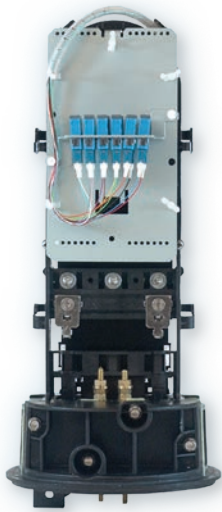

LLAS-200-12SC

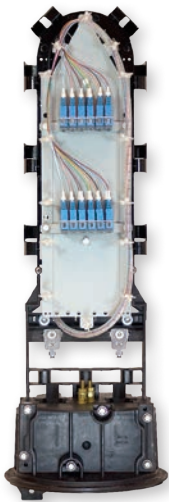

LLAS-300-24SC

LightLink Fiber Optic Terminal Adapters for Sealed Fiber Optic Splice Closures

The LightLink Access Solution (LLAS) Terminal Adapters provide the interconnect and/or demarcation of optical fibers for Fiber-to-the-Node (FTTN), Fiber-to-the-Home (FTTH), Fiber-to-the-Premise (FTTP) and Fiber-to-the-Curb (FTTC) applications. The adapter plates are designed to be used in conjunction with AFL Sealed Fiber Optic Splice Closures and convert the standard closure design into an FTTX or demarcation type fiber optic splice closure. The adapter plates provide mounting positions ranging from six to 24 SC-style bulkheads (depending on the model). The interconnection and routing of 900 μm SC pigtails with pre-connectorized SC drop cables is managed through routing rings on the terminal adapter. Three versions are available and are matched to the LG-150, LG-250 and LG-350 series sealed fiber optic splice closures.

Ordering Information

DESCRIPTION	MODEL NO.	AFL NO.
Terminal Adapter for LG-150/250 Sealed Splice Closure	LLAS-200-12SC	FC000068
Terminal Adapter for LG-350 Sealed Splice Closure	LLAS-300-24SC	FC000069

Blank bulkhead adapter plate and routing rings are included.
SC bulkheads, SC pigtails (900 μm) and SC pre-connectorized drop cable may be ordered separately.

Accessories Ordering

DESCRIPTION	AFL NO.
(1) Small Flange SC/UPC Bulkhead adapter (Blue)	CS013274
(1) Small Flange SC/APC Bulkhead adapter (Green)	CS013083
(1) Pigtail - SC/UPC Connector with (1) meter 900μm fiber	C146507-0001
(1) Pigtail - SC/APC Connector with (1) meter 900μm fiber	C203278-0001

LLAS-200-12SC

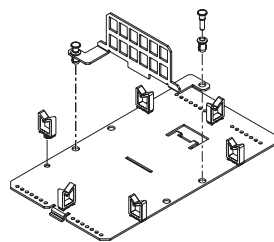

LLAS-300-24SC

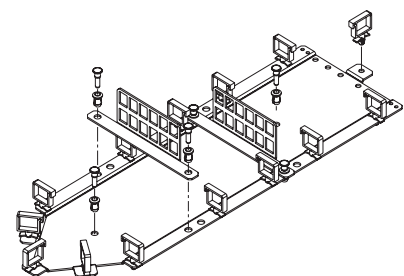



LightGuard® Aerial Weathertight Fiber Optic Splice Closures

The AFL family of Aerial Weathertight Splice Closures is designed to provide a cost-effective solution for your aerial splicing needs. Quality engineering reduces the installation time, training and complexity associated with fiber splicing in the field. The closures have all been designed to be installed without the need for special tools, heat, adhesives, drills or any powered equipment. Durable and easy to install, these closures will improve productivity, reduce labor expenses and last the life of the plant.

Features

- Individual, patented, self-sizing cable grommets and strength member tie downs provide for cable additions without disturbing those previously installed
- Unique tongue-in-groove closure seal and back-to-back grommet design provides for a weathertight and insect seal
- Closures are re-enterable without the need for any re-entry kits and require only a common can wrench for installation

Specifications

PARAMETER	LG-410-U-0	LG-420-U-0	LG-500-U-0	LG-600-U-0
Splice Capacity (Max.) – Single, Mass, Mechanical	144, 432, 36	12, 48, 12	144, 432, 36	384, 1152, 96
Splice Tray Capacity – Single, Mass	4, 2	n/a, n/a	4, 2	12, 8, 8
Cable Ports	4-8	4-6	4-8	6 (3 per end)
Cable Entrance	In-line, Butt	In-line (taut sheath)	In-line, Butt	In-line, Butt
Cable Sizes (O.D.)	4 @ 0.3-0.82" Up to 8 with Dual Grommet Kits 4 @ 0.27-0.53" 4 @ 0.38-0.70"	4 @ 0.3-0.82" Up to 6 with Dual Grommet Kits 2 @ 0.27-0.53" 2 @ 0.38-0.70"	4 @ 0.3-0.82" Up to 8 with Dual Grommet Kits 4 @ 0.27-0.53" 4 @ 0.38-0.70"	6 @ 0.44 - 1.0" Up to 12 with Dual Grommet Kits 6 @ 0.4-0.6" 6 @ 0.7-0.9"
CLOSURE TEST ^{1,2}				
- Cable Retention (100 lbs.)	Passed	Passed	Passed	Passed
- Impact Resistance (0-40 °C)	Passed	Passed	Passed	Passed
- Chemical Resistance	Passed	Passed	Passed	Passed
- Cable Flexing	Passed	Passed	Passed	Passed
- Dust (Weather Tightness)	Passed	Passed	Passed	Passed
- Driving Rain	Passed	Passed	Passed	Passed
- Rodent Test	Passed	Passed	Passed	Passed
Dimensions (L x W x D) in. (cm)	36.00 x 8.00 x 4.00 (91.44 x 20.32 x 10.16)	36.00 x 8.00 x 4.00 (91.44 x 20.32 x 10.16)	27.00 x 8.25 x 4.00 (68.58 x 20.96 x 10.16)	27.00 x 11.25 x 7.50 (68.58 x 28.58 x 19.05)
Weight lbs. (kg)	8.5 (3.86)	8.5 (3.86)	6.4 (2.90)	18 (8.16)

- NOTES:**
1. Tested to Telcordia GR-771-Core and Aerial Strand requirements
 2. Not all Telcordia tests are listed due to space constraints; All closures are designed and tested to appropriate aerial test requirements

Qualifications

GOVERNING BODY	STANDARD CODE
Telcordia	GR-771
Rural Utilities Service (RUS)	Listed

Contact AFL for further details.

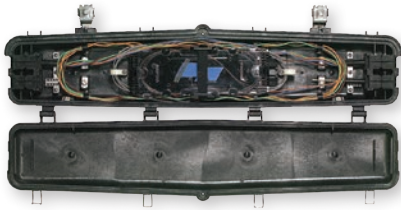

LightGuard® 410 Aerial Weathertight Fiber Optic Splice Closure

The LightGuard (LG) 410 Aerial Weathertight Fiber Optic Splice Closure is designed for medium count fiber splicing (up to 144 single or 432 mass) in a butt or in-line configuration. Utilized in aerial applications, the LG-410 provides additional fiber bundle storage with its extended length design and requires only a common can wrench for installation.

Features

- Four individual, self-sizing grommeted cable ports (expandable to eight cable entrances)
- Patented tongue-in-groove cover seal system
- Installation and re-entry only require a common can wrench
- Cable retention clamps provide pullout
- UV-resistant engineered thermoplastic

Specifications

PARAMETER	VALUE
Splice Capacity (Max.) – Single, Mass, Mechanical	144/432/36
Number of Splice Trays (Max.) – Single, Mass, Mechanical*	4, 3, 4
Cable Entrance Configuration	Butt or in-line
Cables	4 to 8
Cable Sizes (Min. O.D. - Max. O.D.) Included Grommets Single in. (mm)	(4) Cable Ports 4 @ 0.38" - 0.82" (7.6 - 20.8)
Additional Grommets Dual Grommet in. (mm)	Sm: 0.27" - 0.53" (6.9 - 13.5) Lg: 0.38" - 0.70" (9.5 - 17.8)
6-port Multi-Drop Grommet in. (mm)	0.20" - 0.37" (5.1 - 9.4)
Dimensions – (L x D) in. (mm)	36.00" x 8.0" x 4.0" (914.0 x 203.0 x 102.0)
Weight – lbs. (kg)	8.5 (3.81)

continued
→

LightGuard® 410 Aerial Weathertight Fiber Optic Splice Closure

Ordering Information

DESCRIPTION	MODEL NO.	AFL NO.
LG-410 Aerial Weathertight Fiber Optic Splice Closure – Stores 144 single fusion or 432 mass fusion, includes (4) cable kits for sealing/retention and (2) ground terminals with removable bond, and hanger brackets. Not included: Splice Trays or Cable Grounding Kits	LG-410-U-0	FC000022
LL-2400 Single Splice Tray – Stores (24) single fusion splices. Maximum of 4 trays in the LG-410.	LL-2400	91710-06
LL-2448 Universal Splice Tray – Stores (24) single fusion or (4) mass fusion splices (48 F). Maximum of 3 trays in the LG-410.	LL-2448	911289-00-02
LL-4848 Mass Splice Tray – Stores (12) mass fusion splices (144 F). Maximum of 3 trays in the LG-410.	LL-4848	911437-00-02
LL-2448-48S Single Splice Tray – Stores (48) single fusion splices. Maximum of 3 trays in the LG-410.	LL-2448-48S	FA000045
Small Single Grommet Kit (10 pc grommet only) – (Min 0.38" - Max 0.82")	Small Single Grommet Kit (10)	911496-00-00
Small Dual Grommet Kit – Includes: (2) small dual grommets and hardware (Min 0.27" - Max 0.53" and Min 0.38" - Max 0.70")	Small Dual Grommet Kit	911386-00-01
Small Dual Grommet Kit (10 pc grommet only) – (Min 0.27" - Max 0.53" and Min 0.38" - Max 0.70")	Small Dual Grommet Kit (10)	911495-00-00
Small 6-Port Drop Cable Kit – 2 grommets with tie wrap and foam Allows six cable entries (Min 0.20" - Max 0.365" and flat drop)	Small 6 Port Drop Kit	FC000573
Large Single Grommet Kit with retention hardware (Min 0.44" - Max 1.04")	Large Single Grommet Kit	FC000623
Small 6-Port Drop Cable Kit (10 pc grommet only) (Min 0.20" - Max 0.365" and flat drop)	Small Drop Grommet Kit (10)	FC000644
Large Single Grommet Kit (10 pc grommet only) (Min 0.44" - Max 1.04")	Large Single Grommet Kit (10)	91918-00
Large Dual Grommet Expansion Kit—Includes: (2) Dual grommets and hardware (Min .40"-Max .70" and Min 0.60" - Max 0.90")	Large Dual Grommet Kit	911406-00-00
Large 6 Port Drop Cable Kit—2 Grommets with retention bracket. Allows six cable entries (Min 0.23" - Max 0.48" and flat drop)	Large 6 Port Drop Kit	FC000352
Adjustable Aerial Hanger Kit Bracket Kit (included with closure)	Adjustable Hanger LG-400/500/600	911497-00-00
Extended Offset Aerial Hanger Kit LG-400/500/600	Offset Hanger LG-400/500/600	91990-00
Retention hardware for additional cables or replacement hardware—LG-400/500/600 (no grommets)	Cable Retention Kit LG-400\500\600	FC000356
Closure Extension Kit - Used to join multiple closures for extended sheath openings required to repair cable sheath and damaged fibers	Closure Extension Kit LG-400/500/600	911499-00-00
1x6 Fiber Router Kit with furcation tubes.	1x6 Fiber Router	FC000070
Cable Grounding Kit (pack of 5)—Clamp-On Ground Cable Only	CGK-5	FC001091
*Mechanical Splice Kit. Includes 10 pieces of VHB tape. Used in all splice trays. Each piece holds 12 splices.	VHB Tape	FA000089

* See Accessory Specifications. See Splice Tray Specifications.

Qualifications

GOVERNING BODY	STANDARD CODE
Telcordia	GR-771
Rural Utilities Service (RUS)	Listed

Contact AFL for further details.

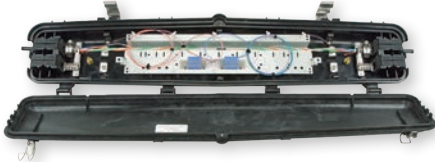

LightGuard® 420 Aerial Weathertight Fiber Optic Splice Closure

The LightGuard (LG) 420 Aerial Weathertight Fiber Optic Splice Closure is designed for taut sheath (no slack) splicing (up to 24 single or 48 mass) in an in-line configuration. Utilized in aerial applications, the LG-420 is ideal for repairing cable sheath or fibers, providing mid-span access and requires only a common can wrench for installation.

Features

- Four individual, self-sizing grommets cable ports (expandable to eight cable entrances)
- Taut Sheath splice module accommodates up to 12 fusion splices
- Protective channel allowing taut fibers or bundles to pass through the closure
- Patented tongue-in-groove cover seal system
- Installation and re-entry only require a common can wrench
- Cable retention clamps provide pullout
- UV-resistant engineered thermoplastic

Specifications

PARAMETER	VALUE
Splice Capacity (Max.) – Single, Mass, Mechanical	24, 48, 12
Number of Splice Trays (Max.) – Single, Mass, Mechanical*	Splice chips for 24F single fusion splice (incl.)
Cable Entrance Configuration	In-line (taut sheath)
Cables	4 to 8
Cable Sizes (Min. O.D. - Max. O.D.) Included Grommets Single in. (mm) Additional Grommets Dual Grommet in. (mm)	(4) Cable Ports 4 @ 0.38" - 0.82" (7.6 - 20.8) Sm: 0.27" - 0.53" (6.9 - 13.5) Lg: 0.38" - 0.70" (9.5 - 17.8)
6-port Multi-Drop Grommet in. (mm)	0.20" - 0.37" (5.1 - 9.4)
Dimensions – (L x D) in. (mm)	36.0" x 8.0" x 4.0" (914.0 x 203.0 x 102.0)
Weight – lbs. (kg)	8.5 (3.81)

continued
→

LightGuard® 420 Aerial Weathertight Fiber Optic Splice Closure

Ordering Information

DESCRIPTION	MODEL NO.	AFL NO.
LG-420 Aerial Weathertight Fiber Optic Splice Closure – Stores 12 single fusion or 48 mass fusion, includes (4) cable kits for sealing/retention and (2) ground terminals with removable bond, splice chips and hanger brackets. Not included: Cable Grounding Kits	LG-420-U-0	FC000023
Small Single Grommet Kit (10 pc grommet only) (Min 0.38" - Max 0.82")	Small Single Grommet Kit (10)	911496-00-00
Small Dual Grommet Kit – Includes: (2) small dual grommets and hardware (Min 0.27" - Max 0.53" and Min 0.38 - Max 0.70")	Small Dual Grommet Kit	911386-00-01
Small Dual Grommet Kit (10 pc grommet only) (Min 0.27" - Max 0.53" and Min 0.38 - Max 0.70")	Small Dual Grommet Kit (10)	911495-00-00
Small 6-Port Drop Cable Kit – 2 grommets with tie wrap and foam. Allows six cable entries (Min 0.20" - Max 0.365" and flat drop)	Small 6 Port Drop Kit	FC000644
Adjustable Aerial Hanger Kit Bracket Kit (included with closure)	Adjustable Hanger LG-400/500/600	911497-00-00
Extended Offset Aerial Hanger Kit LG-400/500/600	Offset Hanger LG-400/500/600	91990-00
Retention hardware for additional cables or replacement hardware – LG-400/500/600 (no grommets)	Cable Retention Kit LG-400/500/600	FC000356
Closure Extension Kit – Used to join multiple closures for extended sheath openings required to repair cable sheath and damaged fibers	Closure Extension Kit LG-400/500/600	911499-00-00
1x6 Fiber Router Kit with furcation tubes	1x6 Fiber Router	FC000070
Cable Grounding Kit (pack of 5) – Clamp-On Ground Cable Only	CGK-5	FC001091
*Mechanical Splice Kit. Includes 10 pieces of VHB tape. Used in all splice trays. Each piece holds 12 splices.	VHB Tape	FA000089

* See Accessory Specifications. See Splice Tray Specifications.

Qualifications

GOVERNING BODY	STANDARD CODE
Telcordia	GR-771
Rural Utilities Service (RUS)	Listed

Contact AFL for further details.

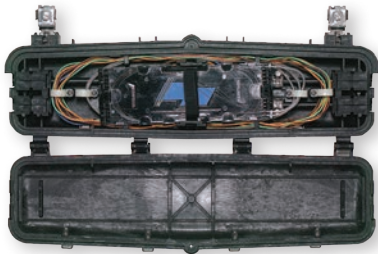

LightGuard® 500 Aerial Weathertight Fiber Optic Splice Closure

The LightGuard (LG) 500 Aerial Weathertight Fiber Optic Splice Closure is designed for medium count fiber splicing (up to 144 single or 432 mass) in a butt or in-line configuration. Utilized in aerial applications, the LG-500 is ideal for congested aerial construction due to its compact design and requires only a common can wrench for installation.

Features

- Four individual, self-sizing grommeted cable ports (expandable up to eight cable entrances)
- Patented tongue-in-groove cover seal system
- Installation and re-entry only require a common can wrench
- Cable retention clamps provide pullout
- UV resistant engineered thermoplastic

Specifications

PARAMETER	VALUE
Splice Capacity (Max.) – Single, Mass, Mechanical	144, 432, 36
Number of Splice Trays (Max.) – Single, Mass, Mechanical*	4, 3, 4
Cable Entrance Configuration	Butt or in-line
Cables	4 to 8
Cable Sizes (Min. O.D. - Max. O.D.) Included Grommets Single in. (mm) Additional Grommets Dual Grommet in. (mm)	(4) Cable Ports 4 @ 0.38" - 0.82" (7.6 - 20.8) Sm: 0.27" - 0.53" (6.9 - 13.5) Lg: 0.38" - 0.70" (9.5 - 17.8)
6-port Multi-Drop Grommet in. (mm)	0.20" - 0.37" (5.1 - 9.4)
Dimensions – (L x D) in. (mm)	27.0" x 8.3" x 4.0" (686.0 x 210.0 x 102.0)
Weight – lbs. (kg)	6.4 (2.90)

continued
→

LightGuard® 500 Aerial Weathertight Fiber Optic Splice Closure

Ordering Information

DESCRIPTION	MODEL NO.	AFL NO.
LG-500 Aerial Weathertight Fiber Optic Splice Closure – Stores 144 single fusion or 432 mass fusion, includes (4) cable kits for sealing/retention and (2) ground terminals with removable bond, and hanger brackets. Not included: Splice Trays or Cable Grounding Kits	LG-500-U-0	FC000026
LL-2400 Single Splice Tray – Stores (24) single fusion splices. Maximum of 4 trays in the LG-500.	LL-2400	91710-06
LL-2448 Universal Splice Tray – Stores (24) single fusion or (4) mass fusion splices (48 F) , *Mechanical. Maximum of 3 trays in the LG-500.	LL-2448	911289-00-02
LL-4848 Mass Splice Tray – Stores (12) mass fusion splices (144 F). Maximum of 3 trays in the LG-500.	LL-4848	911437-00-02
LL-2448-48S Single Splice Tray – Stores (48) single fusion splices. Maximum of 3 trays in the LG-500.	LL-2448-48S	FA000045
Small Single Grommet Kit (10 pc grommet only) – (Min 0.38" - Max 0.82")	Small Single Grommet Kit (10)	911496-00-00
Small Dual Grommet Kit – Includes: (2) small dual grommets and hardware (Min 0.27" - Max 0.53" and Min 0.38" - Max 0.70")	Small Dual Grommet Kit	911386-00-01
Small 6-Port Drop Cable Kit – 2 grommets with tie wrap and foam. Allows six cable entries. (Min 0.20" - Max 0.365" and flat drop)	Small 6 Port Drop Kit	FC000573
Adjustable Aerial Hanger Kit Bracket Kit (included with closure)	Adjustable Hanger LG-400/500/600	911497-00-00
Extended Offset Aerial Hanger Kit for LG-400/500/600	Offset Hanger LG-400/500/600	91990-00
Retention hardware for additional cables or replacement hardware – LG-400/500/600 (no grommets)	Cable Retention Kit LG 400/500/600	FC000356
Closure Extension Kit – Used to join multiple closures for extended sheath openings required to repair cable sheath and damaged fibers	Closure Extension Kit LG-400/500/600	911499-00-00
1x6 Fiber Router Kit with furcation tubes.	1x6 Fiber Router	FC000070
Cable Grounding Kit (pack of 5) – Clamp -On Ground Cable Only	CGK-5	FC001091
*Mechanical Splice Kit. Includes 10 pieces of VHB tape. Used in all splice trays. Each piece holds 12 splices.	VHB Tape	FA000089

* See Accessory Specifications. See Splice Tray Specifications.

Qualifications

GOVERNING BODY	STANDARD CODE
Telcordia	GR-771
Rural Utilities Service (RUS)	Listed

Contact AFL for further details.

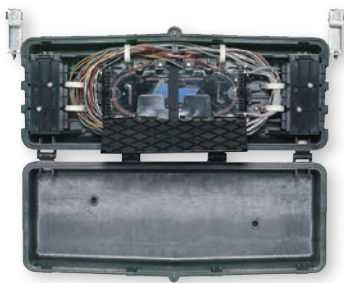

LightGuard® 600 Aerial Weathertight Fiber Optic Splice Closure

The LightGuard (LG) 600 Aerial Weathertight Fiber Optic Splice Closure is designed for high count fiber splicing (up to 384 single or 1152 mass) in a butt or in-line configuration. Utilized in aerial applications, the LG-600 is an ideal cost-effective solution for high fiber count splicing and requires only a common can wrench for installation.

Features

- Six individual, self-sizing grommeted cable ports (expandable to 12 cable entrances)
- Patented tongue-in-groove cover seal system
- Installation and re-entry only require a common can wrench
- Integrated grounding clamp through aerial hangers
- Cable retention clamps provide pullout
- UV resistant engineered thermoplastic

Specifications

PARAMETER	VALUE
Splice Capacity (Max.) – Single, Mass, Mechanical	384, 1152, 36
Number of Splice Trays (Max.) – Single, Mass, Mechanical*	12, 8, 8
Cable Entrance Configuration	Butt or in-line
Cables	6 to 24
Cable Sizes (Min. O.D. - Max. O.D.) Included Grommets Single in. (mm)	(6) Cable Ports 0.44" - 1.00" (11.2 - 25.4)
Additional Grommets Dual Grommet in. (mm)	Sm: 0.40" - 0.70" (10.0 - 17.8) Lg: 0.60" - 0.90" (15.3 - 22.9)
6-port Multi-Drop Grommet in. (mm)	0.30" - 0.48" (7.6 - 17.8)
Dimensions – (L x D) in. (mm)	27.0" x 11.3" x 7.5" (690.0 x 286.0 x 190.5)
Weight – lbs. (kg)	18.0 (8.16)

continued
→

LightGuard® 600 Aerial Weathertight Fiber Optic Splice Closure

Ordering Information

DESCRIPTION	MODEL NO.	AFL NO.
LG-600 Aerial Weathertight Fiber Optic Splice Closure – Stores 384 single fusion or 1152 mass fusion, includes (4) cable kits for sealing/retention and (2) ground terminals with removable bond and hanger brackets. Not included: Splice Trays or Cable Grounding Kits	LG-600-U-0	FC000029
LL-2400 Single Splice Tray – Stores (24) single fusion splices. Maximum of 12 trays in the LG-600.	LL-2400	91710-06
LL-2448 Universal Splice Tray – Stores (24) single fusion or (4) mass fusion splices (48 F). Maximum of 8 trays in the LG-600, *Mechanical	LL-2448	911289-00-02
LL-4848 Mass Splice Tray – Stores (12) mass fusion splices (144 F). Maximum of 8 trays in the LG-600.	LL-4848	911437-00-02
LL-2448-48S Single Splice Tray – Stores (48) single fusion splices. Maximum of 8 trays in the LG-600.	LL-2448-48S	FA000045
Large Single Grommet Kit with retention hardware (Min 0.44" - Max 1.00")	Large Single Grommet Kit	FC000623
Large Single Grommet Kit (10 pc grommet only) – (Min 0.44" - Max 1.00")	Large Single Grommet Kit (10)	91918-00
Large Dual Grommet Expansion Kit – Includes: (2) Dual grommets and hardware (Min 0.40" - Max 0.70" and Min 0.60" - Max 0.90")	Large Dual Grommet Kit	911406-00-00
Large 6 Port Drop Cable Kit – 2 Grommets with retention bracket. Allows six cable entries. (Min 0.23" - Max 0.48" and flat drop)	Large 6 Port Drop Kit	FC000352
Adjustable Aerial Hanger Kit Bracket Kit (included with closure)	Adjustable Hanger LG-400/500/600	911497-00-00
Extended Offset Aerial Hanger Kit LG-400/500/600	Offset Hanger LG-400/500/600	91990-00
SC 6-pack bracket kit for LG-600	Bracket Kit (6-pack SC) LG-600	FM001294
Retention hardware for additional cables or replacement hardware – LG-400/500/600 (no grommets)	Cable Retention Kit LG-400/500/600	FC000356
Closure Extension Kit – Used to join multiple closures for extended sheath openings required to repair cable sheath and damaged fibers	Closure Extension Kit LG-400/500/600	911499-00-00
1x6 Fiber Router Kit with furcation tubes	1x6 Fiber Router	FC000070
Cable Grounding Kit (pack of 5) – Clamp -On Ground Cable Only	CGK-5	FC001091
*Mechanical Splice Kit. Includes 10 pieces of VHB tape. Used in all splice trays. Each piece holds 12 splices.	VHB Tape	FA000089

* See Accessory Specifications. See Splice Tray Specifications.

Qualifications

GOVERNING BODY	STANDARD CODE
Telcordia	GR-771
Rural Utilities Service (RUS)	Listed

Contact AFL for further details.



LightGuard® 420 FTTx Aerial Weathertight Fiber Optic Splice Closure

The LightGuard (LG) 420 FTTx Aerial Weathertight Fiber Optic Splice Closure is designed for taut sheath (no slack) splicing (up to 32 single) in an in-line configuration. Utilized in aerial applications, the LG-420-FTTx is ideal for FTTx access networks by providing access for up to 12 drop cables and 16 connections, requiring only a common can wrench for installation.

Features

- Four individual, self-sizing grommeted cable ports:
 - 2 express ports
 - 2 multi-drop ports
- 12 drop cables and 16 connections
- Special multi-drop grommet and cable retention
- Special lock-out interior enclosure
- Patented tongue-in-groove cover seal system
- Installation and re-entry only require a common can wrench
- Cable retention clamps provide pullout
- UV resistant engineered thermoplastic

Specifications

PARAMETER	VALUE
Splice Capacity (Max.) – Single, Mass, Mechanical	32, n/a, 12
Number of Splice Trays (Max.) – Single, Mass, Mechanical*	1, n/a, 1
Cable Entrance Configuration	In-line (taut sheath)
Cables	2 to 4 Express with up to 12 Drop
Cable Sizes (Min. O.D. - Max. O.D.) Included Grommets	(4) Cable Ports
Single in. (mm)	2 @ 0.38" - 0.82" (7.6 - 20.8)
6-port Multi-Drop Grommet in. (mm)	2 (6 port) @ 0.20" - 0.37" (5.1 - 9.4)
Additional Grommets	
Dual Grommet in. (mm)	Sm: 0.27" - 0.53" (6.9 - 13.5)
	Lg: 0.38" - 0.70" (9.5 - 17.8)
6-port Multi-Drop Grommet in. (mm)	0.20" - 0.37" (5.1 - 9.4)
Dimensions – (L x D) in. (mm)	36.0" x 8.0" x 4.0" (914.0 x 203.0 x 102.0)
Weight – lbs. (kg)	8.5 (3.81)

continued
→

LightGuard® 420 FTTx Aerial Weathertight Fiber Optic Splice Closure

Ordering Information

DESCRIPTION	MODEL NO.	AFL NO.
The AFL LightGuard (LG) 420 FTTx Aerial Weathertight Fiber Optic Splice Closures are designed to allow taut sheath (no slack) or conventional splicing in aerial applications such as FTTx access networks. The LG-420 FTTx provides access for 1 to 16 connections and up to 12 subscriber drops and requires only a common can wrench for installation. Includes: Hanger Brackets and Splice Tray. Not included: Cable Grounding Kits.	LG-420-U-FTTx	FC000099
LL-2425 Single Splice Tray – Stores (32) single fusion splices. Maximum of 1 tray in the LG-420-FTTx.	LL-2425	FC000053
Small Single Grommet Kit of (10 pc grommet only) – (Min .38" - Max .82")	Small Single Grommet Kit (10)	911496-00-00
Small Dual Grommet Kit – Includes: (2) small dual grommets and hardware (Min .27" - Max .53" and Min .38" - Max .70")	Small Dual Grommet Kit	911386-00-01
Small Dual Grommet Kit (10 pc grommet only) – (Min .27" - Max .53" and Min .38" - Max .70")	Small Dual Grommet Kit (10)	911495-00-00
Small 6-Port Drop Cable Kit – 2 grommets with tie wrap and foam. Allows six cable entries (Min 0.20" - Max 0.365" and flat drop)	Small 6 Port Drop Kit	FC000644
Adjustable Aerial Hanger Kit Bracket Kit (included with closure)	Adjustable Hanger LG-400/500/600	911497-00-00
Extended Offset Aerial Hanger Kit LG-400/500/600	Offset Hanger LG-400/500/600	91990-00
Retention hardware for additional cables or replacement hardware – LG-400/500/600 (no grommets)	Cable Retention Kit LG-400/500/600	FC000356
Closure Extension Kit – Used to join multiple closures for extended sheath openings required to repair cable sheath and damaged fibers	Closure Extension Kit LG-400/500/600	911499-00-00
1x6 Fiber Router Kit with furcation tubes.	1x6 Fiber Router	FC000070
Cable Grounding Kit (pack of 5) – Clamp-On Ground Cable Only	CGK-5	FC001091
*Mechanical Splice Kit. Includes 10 pieces of VHB tape. Used in all splice trays. Each piece holds 12 splices.	VHB Tape	FA000089

* See Accessory Specifications. See Splice Tray Specifications.

Qualifications

GOVERNING BODY	STANDARD CODE
Telcordia	GR-771
Rural Utilities Service (RUS)	Listed

Contact AFL for further details.

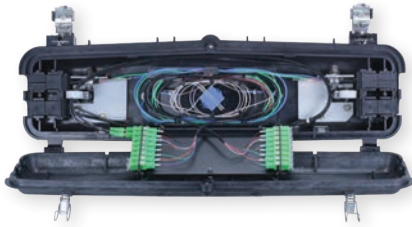

LightGuard® 500 FTTx Aerial Weathertight Fiber Optic Splice Closures

The LightGuard (LG) 500 FTTx Aerial Weathertight Fiber Optic Splice Closure is designed for small count fiber splicing (up to 32 single or 48 mass) in a butt or in-line configuration. Utilized in aerial applications, the LG-500-FTTx is ideal for FTTx access networks by providing cable entry and connectivity for up to 12 drop cables and 16 connections, requiring only a common can wrench for installation.

Features

- Four individual, self-sizing grommets cable ports:
 - 2 express ports
 - 2 multi-drop ports
- 12 drop cables and 16 connections
- Special multi-drop grommet and cable retention
- Special lock-out interior enclosure
- Patented tongue-in-groove cover seal system
- Installation and re-entry only require a common can wrench
- Cable retention clamps provide pullout
- UV resistant engineered thermoplastic

Specifications

PARAMETER	VALUE
Splice Capacity (Max.) – Single, Mass, Mechanical	32, 48, 12
Number of Splice Trays (Max.) – Single, Mass, Mechanical*	1, 1, 1
Cable Entrance Configuration	Butt or in-line
Cables	2 to 4 Express with up to 12 Drop
Cable Sizes (Min. O.D. - Max. O.D.) Included Grommets	(4) Cable Ports
Single in. (mm)	4 @ 0.38" - 0.82" (7.6 - 20.8)
6-port Multi-Drop Grommet in. (mm)	2 (6 port) @ 0.20" - 0.37" (5.1 - 9.4)
Additional Grommets	
Dual Grommet in. (mm)	Sm: 0.27" - 0.53" (6.9 - 13.5) Lg: 0.38" - 0.70" (9.5 - 17.8)
6-port Multi-Drop Grommet in. (mm)	0.20" - 0.37" (5.1 - 9.4)
Dimensions – (L x D) in. (mm)	27.0" x 8.3" x 4.0" (686.0 x 210.0 x 100.0)
Weight – lbs. (kg)	10.1 (4.58)

continued
→

LightGuard® 500 FTTx Aerial Weathertight Fiber Optic Splice Closure

Ordering Information

DESCRIPTION	MODEL NO.	AFL NO.
LG-500-FTTx Aerial Weathertight Fiber Optic Splice Closure – Stores 32 single fusion or 48 mass fusion, includes (4) cable kits for sealing/retention and (2) ground terminals with removable bond, (1) splice tray, and hanger brackets. Not included: Cable Grounding Kits, SCAPC Adapters	LG-500-FTTx	FC000899
LL-2425 Single Splice Tray – Stores (32) single fusion splices. Maximum of 1 tray in the LG-500-FTTx.	LL-2425	FC000053
Small Single Grommet Kit of (10 pc grommet only) – (Min 0.38" - Max 0.82")	Small Single Grommet Kit (10)	911496-00-00
Small Dual Grommet Kit – Includes: (2) small dual grommets and hardware (Min 0.27" - Max 0.53" and Min 0.38" - Max 0.70")	Small Dual Grommet Kit	911386-00-01
Small Dual Grommet Kit (10 pc grommet only) – (Min 0.27" - Max 0.53" and Min 0.38" - Max 0.70")	Small Dual Grommet Kit (10)	911495-00-00
Small 6-Port Drop Cable Kit – 2 grommets with tie wrap and foam tape. Allows six cable entries. (Min 0.20" - Max 0.37" and flat drop)	Small 6 Port Drop Kit	FC000573
Adjustable Aerial Hanger Kit Bracket Kit (included with closure)	Adjustable Hanger LG-400/500/600	911497-00-00
Extended Offset Aerial Hanger Kit LG-400/500/600	Offset Hanger LG-400/500/600	91990-00
Retention hardware for additional cables or replacement hardware – LG-400/500/600 (no grommets)	Cable Retention Kit LG-400/500/600	FC000356
Closure Extension Kit – Used to join multiple closures for extended sheath openings required to repair cable sheath and damaged fibers	Closure Extension Kit LG-400/500/600	911499-00-00
1x6 Fiber Router Kit with furcation tubes	1x6 Fiber Router	FC000070
Cable Grounding Kit (pack of 5) – Clamp -On Ground Cable Only	CGK-5	FC001091
Mechanical Splice Kit*. Includes 10 pieces of VHB tape. Used in all splice trays. Each piece holds 12 splices.	VHB Tape	FA000089
Single-mode SC Simplex Adapter, Flangeless, Green	SC/APC Adapter	CS009394
SC/APC 900 μm Pigtail, 1.5 Meter Length	ASC, XXX, JH, 001, Q, 001.5, White	CS012973C-001.5

* See Accessory Specifications. See Splice Tray Specifications.

Qualifications

GOVERNING BODY	STANDARD CODE
Telcordia	GR-771
Rural Utilities Service (RUS)	Listed

Contact AFL for further details.

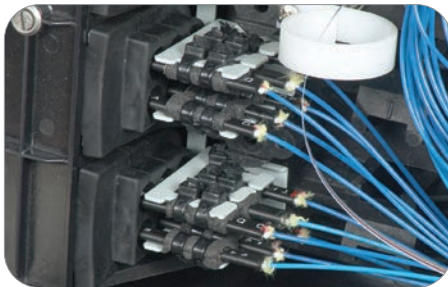

Cable entrance



Grommet bracket

LightGuard® 600 FTTx Aerial Weathertight Fiber Optic Splice Closure

The LightGuard (LG) 600 FTTx Aerial Weathertight Fiber Optic Splice Closure is designed for small count fiber splicing (up to 48 single or 48 mass) in a butt or in-line configuration. Utilized in aerial applications, the LG-600-FTTx is ideal for express slack look fiber access splicing by providing cable entry and connectivity for up to 24 subscriber drops and requires only a common can wrench for installation.

Features

- Six individual, self-sizing grommeted cable ports:
 - 2 express ports
 - 4 multi-drop ports
- Up to 12 adapters using the LG-600 expansion kit and SC 6-pack adapter brackets
- Special multi-drop grommets and cable retention
- Integrated aerial splicing work tray
- Patented tongue-in-groove cover seal system
- Installation and re-entry only require a common can wrench
- Integrated grounding clamp through aerial hangers
- Cable retention clamps provide pullout
- UV resistant engineered thermoplastic

Specifications

PARAMETER	VALUE
Splice Capacity (Max.) – Single, Mass, Mechanical	24, 48, 24
Number of Splice Trays (Max.) – Single, Mass, Mechanical*	2, 2, 2
Cable Entrance Configuration	Butt or in-line
Cables	2 to 4 Express with up to 24 Drops
Cable Sizes (Min. O.D. - Max. O.D.) Included Grommets	(6) Cable Ports 2 @ 0.44" - 1.00" (11.2 - 25.4) 4 @ 0.30" - 0.48" (76 - 17.8)
Single in. (mm)	
6-port Multi-Drop Grommet in. (mm)	
Additional Grommets	
Dual Grommet in. (mm)	Sm: 0.40" - 0.70" (10.0 - 17.8) Lg: 0.60" - 0.90" (15.3 - 22.9)
Dimensions – (L x D) in. (mm)	27.00" x 11.25" x 7.50" (690.0 x 286.0 x 190.5)
Weight – lbs. (kg)	18.0 (8.16)

continued
→

LightGuard® 600 FTTx Aerial Weathertight Fiber Optic Splice Closure

Ordering Information

DESCRIPTION	MODEL NO.	AFL NO.
LG-600-FTTx Aerial Weathertight Fiber Optic Splice Closure – Stores 24 single fusion or 48 mass fusion, includes (6) cable kits for sealing/retention and (2) ground terminals with removable bond, (2) splice tray, and hanger brackets. Not included: Cable Grounding Kits	LG600-FTTx	FC000291
LL-2450 Single Splice Tray – Stores (12) single fusion splices. Maximum of (2) trays in the LG-600-FTTx.	LL-2450	91957-00
LL-4850 Mass Splice Tray – Stores (8) mass fusion splices (96F). Maximum of (2) trays in the LG-600-FTTx.	LL-4850	91958-00
LL-1248 Universal Splice Tray – Stores (12) single fusion splices or (8) mass fusion splices (96F), *Mechanical. Maximum of 2 trays in the LG-600FTTx.	LL-1248	911221-00-00
Large Single Grommet Kit with retention hardware (Min 0.44" - Max 1.00")	Large Single Grommet Kit	FC000623
Large Single Grommet Kit (10 pc grommet only) – (Min 0.44" - Max 1.00")	Large Single Grommet Kit (10)	91918-00
Adjustable Aerial Hanger Kit Bracket Kit (included with closure)	Adjustable Hanger LG-400/500/600	911497-00-00
Extended Offset Aerial Hanger Kit – LG-400/500/600	Offset Hanger LG-400/500/600	91990-00
Retention hardware for additional cables or replacement hardware – LG/400/500/600 (no grommets)	Cable Retention Kit LG-400/500/600	FC000356
Closure Extension Kit – Used to join multiple closures for extended sheath openings required to repair cable sheath and damaged fibers	Closure Extension Kit LG-400/500/600	911499-00-00
1x6 Fiber Router Kit with furcation tubes	1x6 Fiber Router	FC000070
Cable Grounding Kit (pack of 5) – Clamp-On Ground Cable Only	CGK-5	FC001091
*Mechanical Splice Kit. Includes 10 pieces of VHB tape. Used in all splice trays. Each piece holds 12 splices.	VHB Tape	FA000089
LG-600 FTTx Expansion Kit – Includes (1) Stacker Module, (1) SC-6-Pack Bracket. Allows use of standard splice trays.	LG-600 FTTx Expansion Kit	FC000620

* See Accessory Specifications. See Splice Tray Specifications.

Qualifications

GOVERNING BODY	STANDARD CODE
Telcordia	GR-771
Rural Utilities Service (RUS)	Listed

Contact AFL for further details.



LG-600 FTTx/32 Aerial Weathertight Fiber Optic Splice Closure

The LightGuard (LG) 600 FTTx/32 Aerial Weathertight Fiber Optic Splice Closure is designed for small count fiber splicing (up to 96 single or 288 mass) in a butt or in-line configuration. Utilized in aerial applications, the LG-600-FTTx/32 is ideal for accommodating up to 24 drop cables and 32 connections with AFL's slim LGX[®] 118 adapter plate by placing 16 simplex adapters at each end of the inner security enclosure. In addition, the closure can house 1x4, 1x8, 1x16, or 1x32 PLC splitter combinations and requires only a common can wrench for installation.

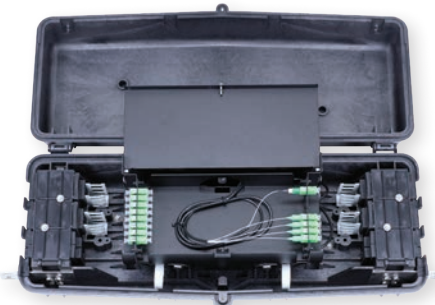

Features

- Six individual, self-sizing grommeted cable ports:
 - 2 express ports
 - 4 multi-drop ports
- Up to 24 FTTx drops
- Up to 32 SC adapters with brackets
- Multi-drop grommets and drop retention for FTTx Drops
- Patented tongue-in-groove cover seal system
- Installation and re-entry only require a common can wrench
- Integrated grounding clamps through aerial hangers
- Cable retention clamps provide pullout
- UV-resistant engineered thermoplastic



Specifications

PARAMETER	VALUE
Splice Capacity (Max.) – Single, Mass, Mechanical	96, 288, 48
Number of Splice Trays (Max.) – Single, Mass, Mechanical*	2, 2, 2
Cable Entrance Configuration	Butt or in-line
Cables	2 to 4 Express with up to 24 Drops
Cable Sizes (Min. O.D. - Max. O.D.) Included Grommets	(6) Cable Ports 2 @ 0.44" - 1.00" (11.2 - 25.4) 4 @ 0.30" - 0.48" (7.6 - 17.8)
Single in. (mm)	
6-port Multi-Drop Grommet in. (mm)	Sm: 0.40" - 0.70" (10.0 - 17.8) Lg: 0.60" - 0.90" (15.3 - 22.9)
Additional Grommets	
Dual Grommet in. (mm)	
Dimensions – (L x D) in. (mm)	27.00" x 11.25" x 7.50" (690.0 x 286.0 x 190.5)
Weight - lbs. (kg)	22.2 (10.06)



Grommeted Cable Ports

continued
→

LG-600 FTTx/32 Aerial Weathertight Fiber Optic Splice Closure

Ordering Information

DESCRIPTION	MODEL NO.	AFL NO.
LG-600-FTTx/32 Aerial Weathertight Fiber Optic Splice Closure – Stores 96 single fusion or 288 mass fusion, includes (6) cable kits for sealing/retention and (2) ground terminals with removable bond, splice tray and hanger brackets. Not included: Cable Grounding Kits	LG-600-FTTx/32	FC000806
LL-2450 Single Splice Tray – Stores (12) single fusion splices. Maximum of 2 trays in the LG-600-FTTx/32.	LL-2450	91957-00
LL-4850 Mass Splice Tray – Stores (8) mass fusion splices (96 F). Maximum of 2 trays in the LG-600-FTTx/32.	LL-4850	91958-00
LL-1248 Universal Splice Tray – Stores (12) single fusion splices or (8) mass fusion splices (96 F), *Mechanical. Maximum of 2 trays in the LG-600-FTTx/32.	LL-1248	91121-00-00
Large Single Grommet Kit with retention hardware (Min 0.44" - Max 1.00")	Large Single Grommet Kit	FC000623
Large Single Grommet Kit of (10 pc grommet only) (Min 0.44" - Max 1.00")	Large Single Grommet Kit (10)	91918-00
Large Dual Grommet Expansion Kit – Includes: (2) Dual grommets and hardware (Min 0.40" - Max 0.70" and Min 0.60" - Max 0.90")	Large Dual Grommet Kit	911406-00-00
Extended Offset Aerial Hanger Kit LG-400/500/600	Offset Hanger LG-400/500/600	91990-00
Retention hardware for additional cables or replacement hardware – LG-400/500/600 (no grommets)	Cable Retention Kit LG-400/500/600	FC000356
Closure Extension Kit – Used to join multiple closures for extended sheath openings required to repair cable sheath and damaged fibers	Closure Extension Kit LG-400/500/600	911499-00-00
1x6 Fiber Router Kit with furcation tubes.	1x6 Fiber Router	FC000070
Cable Grounding Kit (pack of 5) – Clamp-On Ground Cable Only	CGK-5	FC001091
*Mechanical Splice Kit. Includes 10 pieces of VHB tape. Used in all splice trays. Each piece holds 12 splices.	VHB Tape	FA000089

* See Accessory Specifications. See Splice Tray Specifications.

Qualifications

GOVERNING BODY	STANDARD CODE
Telcordia	GR-771
Rural Utilities Service (RUS)	Listed

Contact AFL for further details.

Interchangeable Grommets
for Fiber Optic Splice Closures and Fiber Enclosures

Splice Closures & Accessories



LL-580



LL-400sx



**LL-400b
(inner 4 grommets)**

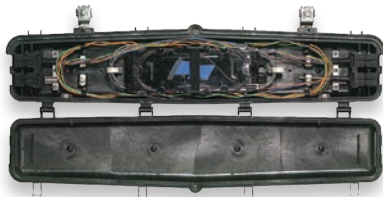

LG-410



**Cable Sealing
Grommets**



LL-500

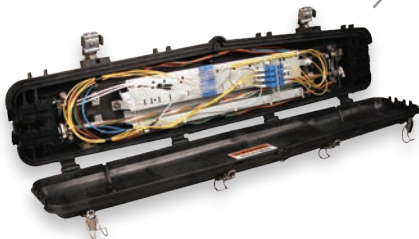

LG-420

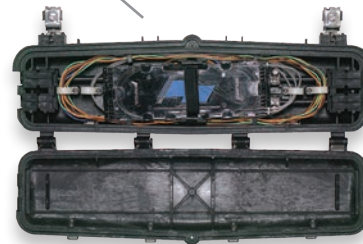

LG-500

continued
→

Interchangeable Large Grommets for Fiber Optic Splice Closures and Fiber Enclosures



LL-400b
(outer 2 grommets)

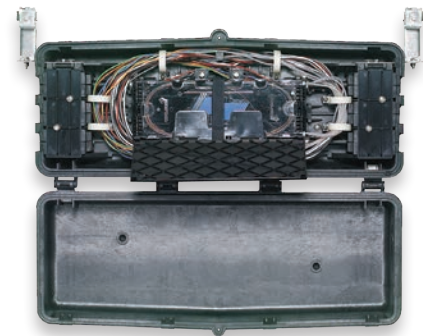

LG-600



LightGuard® Aerial Splice Closure Accessories



Dual-port Grommet Kit



Multi-port Grommet Kit

Dual- and Multi-port Grommet Kits for LG-400/LG-500/LG-600

For use with the LG-600 Aerial Weathertight Closure. Remove the single-port grommet set from the closure and replace with the multi-port grommet set when drops are required. Retention hardware included.

Ordering Information

DESCRIPTION	AFL NO.
Dual-port Grommet Kit for LG-400/LG-500 Diameter for large port is 0.375" - 0.65"; small port, 0.27" - 0.5"	911386-00-01
Dual Grommet Expansion Kit - Includes: (2) Dual Grommets, (1) CSM retention clamp, cable retention clamp and cable spacer	911406-00-00
Dual Grommet Replacement Kit - Includes: (10) Dual Grommets for the LG-400 Series Closures. Diameter for large port is 0.375" - 0.65"; small port, 0.27" - 0.5"	911495-00-00
Grommet Replacement Kit, Kit - Includes: (10) Standard (single port) Grommets for the LG-400 Series Closures. Diameter from 0.3" - 0.82"	911496-00-00
Grommet Replacement Kit - Includes: (10) LG-600 Grommets Diameter from 0.5" - 1.0"	91918-00
Multi-port Grommet Kit for LG-400/LG-500. Diameter up to 0.365"	FC000573
Multi-port Grommet Kit for LG-600. Diameter from 0.67" to 0.475"	FC000352



Single-port Grommet Kit for LG-600 FTTx

For use with the LG-600 Aerial Weathertight Closure. Remove the multi-port grommet set from the closure and replace with the single-port grommet set when installing a branch cable. Hardware included.

Ordering Information

DESCRIPTION	AFL NO.
Single-port Grommet Kit for LG-600 FTTx	FC000623
Single Cable Entry Grommet Kit LG-600 Hardware	FC000356



Adjustable Aerial Hanger Brackets

For use with all Aerial Weathertight Closures (LG-410, LG-420, LG-420 FTTx, LG-500, LG-600 and LG-600 FTTx). This pair of hanger brackets is shipped from the factory with all weathertight closures. Purchase separately for closures installed over existing utilities.

Ordering Information

DESCRIPTION	AFL NO.
Adjustable Aerial Hanger Brackets	911497-00-00

continued
→

LightGuard® Aerial Splice Closure Accessories (cont.)



SC 6-Pack Bracket for LG-600

Installs at each end of the stacker module in the LG-600. Allows up to (12) SC connectors or (24) LC connectors (using duplex connectors) to be installed in the closure. Snaps in place or use self-tapping screws to secure.

Ordering Information

DESCRIPTION	AFL NO.
SC 6-Pack Bracket Kit for LG-600	FM001294
SC 6-Pack Adapter Bracket	FM001212

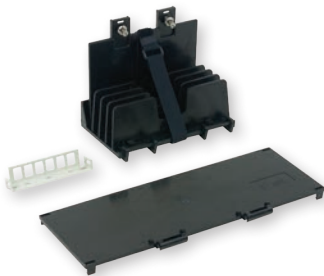

Expansion Kit for LG-600 FTTx

Expansion kit includes a Stacker Tray Module and one LG-600 SC-6-Pack Bracket to allow for up to six SC connections or 12 LC duplex connections. An additional bracket may be used to increase connectivity to 12 SC or 24 LC connections using duplex adapters. Allows increasing splices with LL-2400, LL-2448 and LL-2448-48S splice trays.

Ordering Information

DESCRIPTION	AFL NO.
Expansion Kit for LG-600 FTTx	FC000620



Cable Grounding Harness

For use with all Aerial Weathertight Closures (LG-410, LG-420, LG-420 FTTx, LG-500, LG-600 and LG-600 FTTx).

Ordering Information

DESCRIPTION	AFL NO.
Cable Grounding Harness - Includes: (4) Harness 8" #6 AWG	FC000024

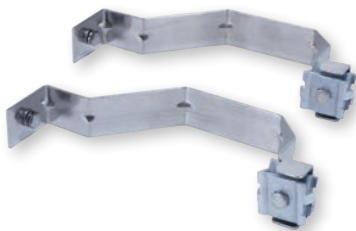

Aerial Hanger Kits

For use with all Aerial Weathertight Closures (LG-410, LG-420, LG-420 FTTx, LG-500, LG-600 and LG-600 FTTx).

Ordering Information

DESCRIPTION	AFL NO.
Extended Aerial Hanger Kit	911497-00-00
Extended Offset Aerial Hanger Kit	91990-00

LightLink Fiber Optic Splice Trays

AFL's LightLink series of Fiber Optic Splice Trays offers a variety of unique and flexible splice and storage possibilities. They are available in industry standard configurations (single, mass).

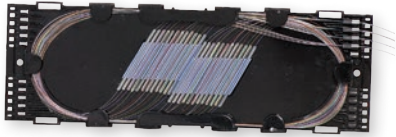

Features

- In-line or butt splice capability (see model descriptions)
- Pre-formed radiuses maintain bend requirements
- Interlocking base and cover provides tray stability without the use of a bolt
- Extended finger guides easily store and route loose fiber or ribbon



Ordering Information—Splice Trays for Sealed Fiber Optic Splice Closures

DESCRIPTION	MODEL NO.	AFL NO.	LG-55-U	LG-150-U	LG-250-U	LG-350-U	LG-350-20-WTC	LG-350-27-WTC
Single Fuse: 32 Mass Fuse: N/A 6.300" (L) x 2.730" (W) x 0.829" (H) 	LL-2425	FC000053	Max trays: 1 Single: 32 Mass: N/A	N/A	N/A	N/A	N/A	N/A
Single Fuse: 12 Mass Fuse: N/A 7.139" (L) x 4.294" (W) x 0.370" (H) 	LL-2450	91957-00	N/A	Max Trays: 4 Single: 48 Mass: N/A	N/A	N/A	N/A	N/A
Single Fuse: N/A Mass Fuse: 8 (96 fiber) 7.139" (L) x 4.294" (W) x 0.370" (H) 	LL-4850	91958-00	N/A	Max Trays: 4 Single: N/A Mass: 32 (384 fiber)	N/A	N/A	N/A	N/A
Single Fuse: 12 Mass Fuse: 8 (96 fiber) 7.139" (L) x 4.294" (W) x 0.370" (H) 	LL-1248	911221-00-00	N/A	Max Trays: 4 Single: 48 Mass: 48 (384 fiber)	N/A	N/A	N/A	N/A
Single Fuse: 24 Mass Fuse: N/A 12.542" (L) x 4.042" (W) x 0.390" (H) 	LL-2400	91710-06	N/A	N/A	Max Trays: 5 Single: 120 Mass: N/A	Max Trays: 13 Single: 312 Mass: N/A	N/A	N/A

continued
→

LightLink Fiber Optic Splice Trays (cont.)

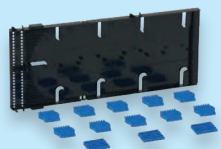
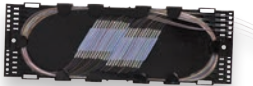
Ordering Information—Splice Trays for Sealed Fiber Optic Splice Closures

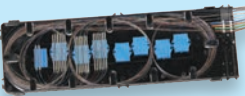
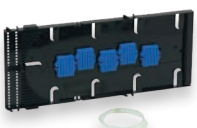
DESCRIPTION	MODEL NO.	AFL NO.	LG-250-U	LG-350-U	LG-350-AC	LG-350XL-U	LG-350-20-WTC	LG-350-27-WTC
Single Fuse: 60 Mass Fuse: 12 (144 fiber) 12.000" (L) x 5.125" (W) x 0.485" (H)  *Note: Contains enough splice holders for 24 mass splices (288 fibers) when using AFL Wrapping Tube Cable.	LL-7644	FA000044	N/A	Max Trays: 6 Single: 360 Mass: 72 (864 fiber)	N/A	N/A	N/A	Max Trays: 3 Single: 180 Mass: 72 (864 fiber)
Single Fuse: 24 Mass Fuse: 4 (48 fiber) 12.542" (L) x 4.270" (W) x 0.531" (H) 	LL-2448	911289-00-02	Max Trays: 3 Single: 72 Mass: 12 (144 fiber) Mechanical: 36	Max Trays: 8 Single: 192 Mass: 32 (384 fiber) Mechanical: 96	N/A	N/A	N/A	N/A
Single Fuse: 48 Mass Fuse: N/A 12.542" (L) x 4.270" (W) x 0.531" (H) 	LL-2448-48S	FA000045	Max Trays: 3 Single: 144 Mass: N/A	Max Trays: 8 Single: 384 Mass: N/A	N/A	N/A	N/A	N/A
Single Fuse: N/A Mass Fuse: 12 (144 fiber) 12.542" (L) x 4.270" (W) x 0.531" (H) 	LL-4848	911437-00-02	Max Trays: 3 Single: N/A Mass: 36 (432 fiber)	Max Trays: 8 Single: N/A Mass: 96 (1152 fiber)	N/A	N/A	N/A	N/A
Single Fuse: 96 Mass Fuse: 24 (288 fiber) 15.950" (L) x 4.875" (W) x 0.485" (H) 	LL-4896	911676-00-02	N/A	Max Trays: 5 Single: 480 Mass: 120 (1440 fiber)	N/A	Max Trays: 9 Single: 864 Mass: 216 (2592 fiber)	N/A	N/A
Single Fuse: 60 Mass Fuse: N/A 12.000" (L) x 5.125" (W) x 0.485" (H) 	LL-7060	FA000042	N/A	Max Trays: 6 Single: 360 Mass: N/A	N/A	N/A	N/A	Max Trays: 3 Single: 180 Mass: N/A

continued
→

LightLink Fiber Optic Splice Trays (cont.)

Ordering Information – Splice Trays for LG-350 and LG-350XL-U Sealed Fiber Optic Splice Closures

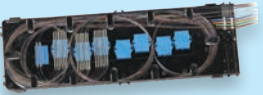
DESCRIPTION	MODEL NO.	AFL NO.	LG-350-U	LG-350-AC	LG-350XL-U	LG-350-20-WTC	LG-350-27-WTC
Single Fuse: N/A Mass Fuse: 12 (144 fiber) 12.000" (L) x 5.125" (W) x 0.485" (H) 	LL-7144	FA000043	Max Trays: 6 Single: 360 Mass: 72 (864 fiber)	N/A	N/A	N/A	Max Trays: 3 Single: 180 Mass: 72 (864 fiber)
Single Fuse: 36 Mass Fuse: 12 (144 fiber) 8.125" (L) x 4.875" (W) x 0.485" (H) 	LL-4808L-R	FA000037	N/A	Max Trays: 4 Single: 144 Mass: 48 (576 fiber)	N/A	Max Trays: 4 Single: 144 Mass: 48 (576 fiber)	N/A
Single Fuse: N/A Mass Fuse: 12 (144 fiber) 8.125" (L) x 4.875" (W) x 0.485" (H) 	LL-4808 R	FA000020	N/A	Max Trays: 4 Single: N/A Mass: 48 (576 fiber)	N/A	Max Trays: 4 Single: N/A Mass: 48 (576 fiber)	N/A
Single Fuse: 36 Mass Fuse: N/A 8.125" (L) x 4.875" (W) x 0.485" (H) 	LL-4808 L	FA000021	N/A	Max Trays: 4 Single: 144 Mass: N/A	N/A	Max Trays: 4 Single: 144 Mass: N/A	N/A
Single Fuse: N/A Mass Fuse: 24 (288 fiber) 15.950" (L) x 4.875" (W) x 0.485" (H) 	LL-4896 R	FA000022	Max Trays: 5 Single: N/A Mass: 120 (1440 fiber)	N/A	Max Trays: 9 Single: N/A Mass: 216 (2592 fiber)	N/A	N/A
Single Fuse: 96 Mass Fuse: N/A 15.950" (L) x 4.875" (W) x 0.485" (H) 	LL-4896 L	FA000023	Max Trays: 5 Single: 480 Mass: N/A	N/A	Max Trays: 9 Single: 864 Mass: N/A	N/A	Max Trays: 3 Single: 180 Mass: N/A

continued



LightLink Fiber Optic Splice Trays (cont.)

Ordering Information – Splice Trays for Aerial Weathertight Fiber Optic Splice Closures

DESCRIPTION	MODEL NO.	AFL NO.	LG-410-U	LG-420-U FTTx	LG-500-U	LG-500-U FTTx
Single Fuse: 24 Mass Fuse: N/A 12.542" (L) x 4.042" (W) x 0.390" (H) 	LL-2400	91710-06	Max Trays: 4 Single: 96 Mass: N/A	N/A	Max Trays: 4 Single: 96 Mass: N/A	N/A
Single Fuse: 32 Mass Fuse: N/A 6.300" (L) x 2.730" (W) x 0.829" (H) 	LL-2425	FC000053	N/A	Max Trays: 1 Single: 32 Mass: N/A	N/A	Max Trays: 1 Single: 32 Mass: N/A
Single Fuse: 24 Mass Fuse: 4 (48 fiber) 12.542" (L) x 4.270" (W) x 0.531" (H) 	LL-2448	911289-00-02	Max Trays: 3 Single: 72 Mass: 12 (144 fiber) Mechanical: 36	N/A	Max Trays: 3 Single: 72 Mass: 12 (144 fiber) Mechanical: 36	N/A
Single Fuse: 12 Mass Fuse: N/A 7.139" (L) x 4.294" (W) x 0.370" (H) 	LL-2450	91957-00	N/A	N/A	N/A	N/A
Single Fuse: N/A Mass Fuse: 12 (144 fiber) 12.542" (L) x 4.270" (W) x 0.531" (H) 	LL-4848	911437-00-02	Max Trays: 3 Single: N/A Mass: 36 (432 fiber)	N/A	Max Trays: 3 Single: N/A Mass: 36 (432 fiber)	N/A
Single Fuse: N/A Mass Fuse: 8 (96 fiber) 7.139" (L) x 4.294" (W) x 0.370" (H) 	LL-4850	91958-00	N/A	N/A	N/A	N/A
Single Fuse: 12 Mass Fuse: 8 (96 fiber) 7.139" (L) x 4.294" (W) x 0.370" (H) 	LL-1248	911221-00-00	N/A	N/A	N/A	N/A

continued
→

LightLink Fiber Optic Splice Trays (cont.)

Ordering Information – Splice Trays for Aerial Weathertight Fiber Optic Splice Closures

DESCRIPTION	MODEL NO.	AFL NO.	LG-500-U-FTTx-ISO	LG-600-U	LG-600-FTTx	LG-600-U-FTTx-ISO
Single Fuse: 24 Mass Fuse: N/A 12.542" (L) x 4.042" (W) x 0.390" (H) 	LL-2400	91710-06	N/A	Max Trays: 12 Single: 288 Mass: N/A	Max Trays: 2 Single: 48 Mass: N/A	N/A
Single Fuse: 32 Mass Fuse: N/A 6.300" (L) x 2.730" (W) x 0.829" (H) 	LL-2425	FC000053	N/A	N/A	N/A	N/A
Single Fuse: 24 Mass Fuse: 4 (48 fiber) 12.542" (L) x 4.270" (W) x 0.531" (H) 	LL-2448	911289-00-02	N/A	Max Trays: 8 Single: 192 Mass: 32 (384 fiber) Mechanical: 12	N/A	N/A
Single Fuse: 12 Mass Fuse: N/A 7.139" (L) x 4.294" (W) x 0.370" (H) 	LL-2450	91957-00	Max Trays: 1 Single: 12 Mass: N/A	N/A	N/A	Max Trays: 2 Single: 24 Mass: N/A
Single Fuse: N/A Mass Fuse: 12 (144 fiber) 12.542" (L) x 4.270" (W) x 0.531" (H) 	LL-4848	911437-00-02	N/A	Max Trays: 8 Single: N/A Mass: 96 (1152 fiber)	N/A	N/A
Single Fuse: N/A Mass Fuse: 8 (96 fiber) 7.139" (L) x 4.294" (W) x 0.370" (H) 	LL-4850	91958-00	Max Trays: 1 Single: N/A Mass: 8 (96 fiber)	N/A	N/A	Max Trays: 2 Single: N/A Mass: 16 (192 fiber)
Single Fuse: 12 Mass Fuse: 8 (96) 7.139" (L) x 4.294" (W) x 0.370" (H) 	LL-1248	911221-00-00	Max Trays: 1 Single: 12 Mass: 8 (96 fiber)	N/A	N/A	Max Trays: 2 Single: 24 Mass: 16 (192 fiber)

continued

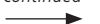





LightLink Fiber Optic Splice Trays (cont.)

Ordering information – Splice Trays for Aerial Weathertight Fiber Optic Splice Closures

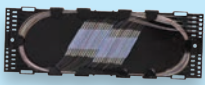
DESCRIPTION	MODEL NO.	AFL NO.	LG-410-U	LG-500-U	LG-600-U
Single Fuse: N/A Mass Fuse: 4 (48 fiber) 12.542" (L) x 4.270" (W) x 0.531" (H) 	LL-4800	91711-07	Max Trays: 3 Single: N/A Mass: 12 (144 fiber)	Max Trays: 3 Single: N/A Mass: 12 (144 fiber)	Max Trays: 8 Single: N/A Mass: 32 (384 fiber)

Ordering Information—Splice Trays for Fiber Optic Enclosures

DESCRIPTION	MODEL NO.	AFL NO.	LL-400B WITH INTERCONNECT	LL-400B WITHOUT INTERCONNECT	LL-400SX WITH 2 LGX® PLATES	LL-400SX WITHOUT LGX PLATES
Single Fuse: 24 Mass Fuse: 4 (48 fiber) Mechanical : 12 12.542" (L) x 4.270" (W) x 0.531" (H) 	LL-2448	911289-00-02	Max Trays: 4 Single: 96 Mass: 16 (192 fiber) Mechanical: 48	Max Trays: 6 Single: 144 Mass: 24 (288 fiber) Mechanical: 72	Max Trays: 3 Single: 72 Mass: 12 (144 fiber) Mechanical: 36	Max Trays: 9 Single: 216 Mass: 36 (432 fiber) Mechanical: 108
Single Fuse: 48 Mass Fuse: N/A 12.542" (L) x 4.270" (W) x 0.531" (H) 	LL-2448-48S	FA000045	Max Trays: 4 Single: 192 Mass: N/A	Max Trays: 6 Single: 288 Mass: N/A	Max Trays: 3 Single: 144 Mass: N/A	Max Trays: 9 Single: 432 Mass: N/A
Single Fuse: N/A Mass Fuse: 12 (144 fiber) 12.542" (L) x 4.270" (W) x 0.531" (H) 	LL-4848	911437-00-02	Max Trays: 4 Single: N/A Mass: 48 (576 fiber)	Max Trays: 6 Single: N/A Mass: 72 (864 fiber)	Max Trays: 3 Single: N/A Mass: 36 (432 fiber)	Max Trays: 9 Single: N/A Mass: 108 (1296 fiber)
Single Fuse: N/A Mass Fuse: 4 (48 fiber) 12.542" (L) x 4.270" (W) x 0.531" (H) 	LL-4800	91711-07	Max Trays: 4 Single: N/A Mass: 16 (192 fiber)	Max Trays: 6 Single: N/A Mass: 24 (288 fiber)	Max Trays: 3 Single: N/A Mass: 12 (144 fiber)	Max Trays: 9 Single: N/A Mass: 108 (1296 fiber)

continued
→

LightLink Fiber Optic Splice Trays (cont.)

Ordering Information—Splice Trays for Fiber Optic Enclosures

DESCRIPTION	MODEL NO.	AFL NO.	LL-500	LL-580
Single Fuse: N/A Mass Fuse: 12 (144 fiber) 12.000" (L) x 5.125" (W) 0.485" (H) 	LL-7144	FA000043	N/A	Max Trays: 2 Single: N/A Mass: 24 (288 fiber)
Single Fuse: 60 Mass Fuse: 12 (144) 12.000" (L) x 5.125" (W) 0.485" (H) 	LL-7644	FA000044	N/A	Max Trays: 2 Single: 120 Mass: 24 (288 fiber)
Single Fuse: 12 Mass Fuse: N/A 7.139" (L) x 4.294" (W) x 0.370" (H) 	LL-2450	91957-00	Max Trays: 5 Single: 60 Mass: N/A	N/A
Single Fuse: N/A Mass Fuse: 8 (96 fiber) 7.139" (L) x 4.294" (W) x 0.370" (H) 	LL-4850	91958-00	Max Trays: 3 Single: N/A Mass: 24 (288 fiber)	N/A
Single Fuse: 36 Mass Fuse: 12 (144 fiber) 8.125" (L) x 4.875" (W) x 0.485" (H) 	LL-4808L-R	FA000037	N/A	Max Trays: 2 Single: 72 Mass: 24 (288 fiber)

continued



LightLink Fiber Optic Splice Trays (cont.)

Ordering Information – Splice Tray for Splicing Cabinets and Shelves

DESCRIPTION	MODEL NO.	AFL NO.
Telescoping Splice Tray - Stores up to 48 single fusion sleeves or 12 mass fusion sleeves (144 fibers). For use in the following products: LL-300, LL-288/576, LL-720/1440, OTSS-SYS1, OSS-SYS2 and OSS-SYS1	STF-48	911442-00-00
FTTx Splice Tray - Stores up to 2 single fusion sleeves. For use in the following products: ONT-760XL, ONT-3000 and CG-1500	—	DM000445
Bare Fiber Splice Tray - Stores up to 24 single fusion fibers without sleeves. For use in the following products: Any product that accepts the LL-2400 splice tray	—	C184190

Ordering Information—Splice Tray Accessories

DESCRIPTION	AFL NO.
FP-40 Splice Protection Sleeves, 40 mm length (1000 box/100 pack)	S015916
FP-60 Splice Protection Sleeves, 60 mm length (1000 box/100 pack)	S015915
Single Fusion Splice Chip - 6 splices per chip. (10 pcs. per kit)	FA000034
Single Fusion Splice Chip - 12 splices per chip. (10 pcs. per kit)	FC000657
Single Fusion Splice Chip - 24 splices per chip. (10 pcs. per kit)	91745-02
Mass Fusion Splice Chip - 4 splices per chip. (10 pcs. per kit)	FA000088
Mechanical Fusion Splice Tape (10 pcs. per kit)	FA000089
Core Tube Cable Fiber Router for routing fiber up to 8 directions. For all central core tube sizes.	FC000008
Loose Tube or Ribbon Router for routing fiber up to 6 directions. For all Loose Tube and up to 12 fiber Ribbon.	FC000070

Dimensions

LL-2448 and LL-4848 Splice Trays

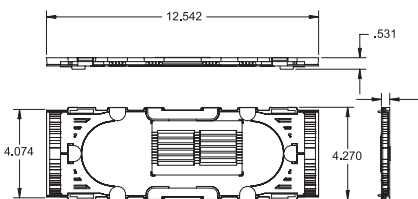

LL-1248, LL-2450 and LL-4850 Splice Trays

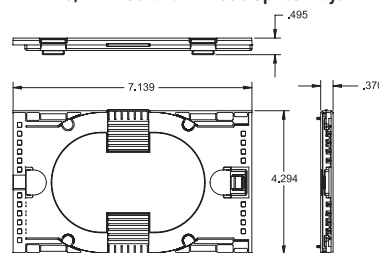

LL-2400 Splice Tray

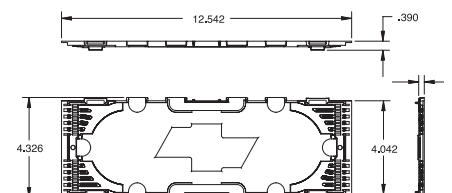

LL-4896 Splice Tray

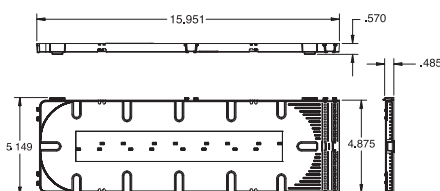

LL-2425 Splice Tray

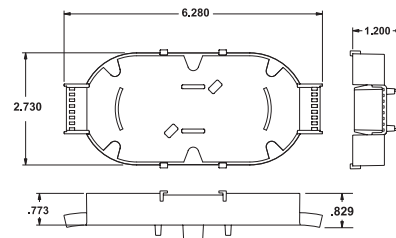

OEE Splice Tray

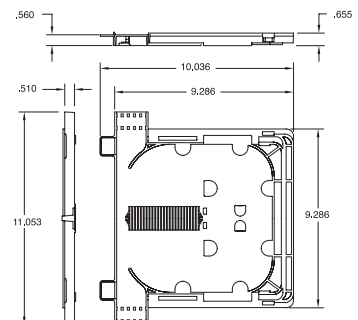

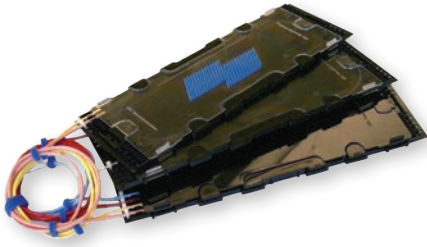

LightLink Splitter Trays

The LightLink Splitter Trays are a packaged system that include factory-preinstalled PLC splitters and splicing trays which easily fit within AFL’s LG Series Closures, LL Series Wall Mount Cabinets and pedestals. These AFL splitter trays feature 1x4, 1x8, 1x16 or 1x32 planar technology with optical characteristics that include low insertion loss, high uniformity, and excellent environmental stability. The products are have longevity and durability in an Outside Plant application.

The splitter couplers are factory-preinstalled and secured within the AFL splice trays. The trays are tamper-proof to prevent unwanted entry. With the lengthy transition tubing preinstalled, the device fibers are routed into the splice trays (included as part of the package) to help complete installations in a timely manner. No additional trays are required reducing material costs.

Features

- Tamper-Proof Packaging
- Fits in all AFL enclosures
- No additional trays required
- Color-coded transportation tubing

Optical Specifications

PARAMETER	VALUE			
	1 X 4	1 X 8	1 X 16	1 X 32
Wavelength Range	1260 - 1650 nm	1260 - 1650 nm	1260 - 1650 nm	1260 - 1650 nm
Max. Insertion Loss	7.5	10.7	14.0	17.4
Max. Uniformity	1.0	1.0	1.2	1.7
PDL (dB) Max.	0.3	0.3	0.3	0.3
Return Loss	50.0	50.0	50.0	50.0
Operating Temperature (°C)	-40 to 85	-40 to 85	-40 to 85	-40 to 85

This tray has capacity for up to 24 single fusion splices and are stackable with each other and other similar AFL splice trays.

Ordering Information

DESCRIPTION	AFL NO.	SIZE
LightLink Splitter	FC000898	Tray PKG 1x2
LightLink Splitter	FC000571	Tray PKG 1x4
LightLink Splitter	FC000539	Tray PKG 1x8
LightLink Splitter	FC000538	Tray PKG 1x16
LightLink Splitter	FC000537	Tray PKG 1x32

Qualifications

GOVERNING BODY	STANDARD CODE
Telcordia	GR-1209 GR-1221-CORE

Contact AFL for further details.



Switchblade® Fiber Containment Vault

Switchblade is an innovative fiber containment vault with a folding design that reduces shipping cost, storage space footprint and increases productivity and speed to market.

The flared design maintains a best-in-class strength to weight ratio – minimizing the effects of frost heave, while optimizing internal volume.

When combined with other AFL products, the Switchblade FCV-2 can comfortably hold 3,456F of spliced fibers using the Apex® X-2 and SWR cable, or multiple TITAN RTD® Multiport Terminals on a mounting bracket.

Specifications

PARAMETER	DESCRIPTION
Dimensions (External)	Top: 28" W x 38" L x 26" D (34" w/ext) Bottom (Flared): 34" W x 44" L x 26" D (34" w/ext)
Dimensions (Internal)	Top: 24" W x 34" L x 24" D (32" w/ ext) Bottom (Flared): 31" W x 41" L x 24" D (32" w/ext)
Dimensions (Folded)	6" W x 62" D x 26" H 6" W x 62" D x 34" H including Extension
Weight – lbs (kg)	Base: 66 lbs (30 kg) Extension: 26 lbs (11.8 kg) Tier 15 Lid: 48 lbs (21.3 kg)

Features

- Folding design reduces shipping cost and storage space footprint
- Lowest weight in category, size and classification
- High strength to weight ratio
- Flared wall design minimizes frost heave and optimizes internal volume
- Non-conductive and non-corrosive
- ANSI/SCTE 77 Tier 15 rating lid options
- Made in the USA

Ordering Information

KIT PART NUMBERS	DESCRIPTION
FCV-2-B-15	Switchblade Fiber Containment Vault Kit Base, No Extension, T15 Lid 24" W x 36" L x 26" D
FCV-2-E-15	Switchblade Fiber Containment Vault Kit Base, Extension, T15 Lid 24" W x 36" L x 34" D
FCV-2-E-XX	Switchblade Fiber Containment Vault Kit Base, Extension, No Lid 24" W x 36" L x 34" D

COMPONENT PART NUMBERS	DESCRIPTION
FCV-2-B-XX	Switchblade Fiber Containment Vault Base 24" W x 36" L x 26" D
FCV-EXT-2-1	Switchblade Fiber Containment Vault Extension 24" W x 36" L x 8" D
FCV-LID-2-15	Switchblade Fiber Containment Vault Tier 15 Lid 24" W x 36" L

Qualifications

GOVERNING BODY	STANDARD CODE
ANSI	SCTE 77 2017
Test Rating – lbf (kN)	Tier 15: 22,500 lbf (100 kN)

Switchblade® Fiber Containment Vault

The collapsible design of Switchblade fiber containment vaults delivers unmatched transportation and storage space efficiency when compared to traditional vaults.

Freight Cost Comparison

Standard 53-ft trucks can transport a total of 200 Switchblade fiber containment vaults on a full truck load (FTL). By comparison, an FTL of traditional vaults is maxed at approximately 50-100 total vaults. Utilizing fewer trucks to deliver more equipment in less deliveries contributes to increased project profitability. Fewer trucks also consume less fuel resulting in positive environmental and sustainability impacts.

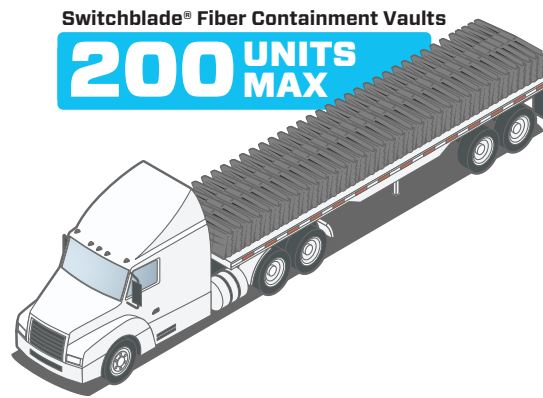
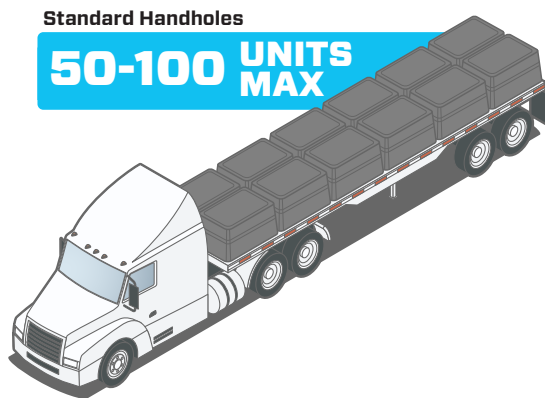

up to **3-4X** More
Vaults Shipped

VAULT TYPE WITH T15 LID	FTL DELIVERY QTY	MAX. VAULTS PER TRUCK	NO. OF FTL 53' TRUCKS	EST. WEIGHT (LBS) PER TRUCK	EST. FREIGHT PER VAULT
AFL Switchblade 24"x36"x26"	600	200	3	22,800	\$25.00
Traditional HDPE/Composite 24"x36"x24"	600	100	6	13,200	\$35.00
Traditional Concrete 24"x36"x24"	600	100	6	32,500	\$70.00

Inventory and Storage Space Savings

Switchblade palletized loads are up to 60% lower in height (26") versus typical vault pallets (72") allowing more pallets to be stacked for significant storage space and cost savings.

VAULT TYPE WITH T15 LID	STORAGE AREA	STORED VAULT QTY
AFL Switchblade 24"x36"x26"	1,275 sq. ft.	600*
Traditional HDPE/Composite 24"x36"x24"	1,275 sq. ft.	300*
Traditional Concrete 24"x36"x24"	1,275 sq. ft.	300*

* Based on maximum stacked pallet height of 78"





Fiber Storage Units

AFL Fiber Storage Units (FSU) are used to conveniently and safely store an extra length of cable along the support strand for later use. Furnished as pairs (kit contains two Fiber Storage Units and two sets of hanger brackets), these FSU's are constructed from either aluminum with a baked acrylic enamel finish or dielectric polypropylene with a UV inhibitor. All basic hardware for attachment to the support strand is provided. Strand mount support brackets meet Telcordia® specifications. Galvanized strand clamping devices accommodate 1/4" to 7/16" strand and meet ASTM specifications A153 and B695.

Features

- Small profile and side facing channel minimizes ice and leaf loading
- Metal versions feature an all aluminum construction with welded cross members and baked acrylic enamel paint finish with chromate pre-finish per MIL-6-5541-B
- Plastic versions feature thermoplastic polypropylene resin with carbon black UV inhibitor
- Basic hanging hardware (bolts, nuts, washers) and strand clamps all included
- Tie-wrap slots for securing cable from sliding
- Galvanized strand clamps accommodate 1/4" to 7/16" strand



Reserve Cable Storage



Butt Splice

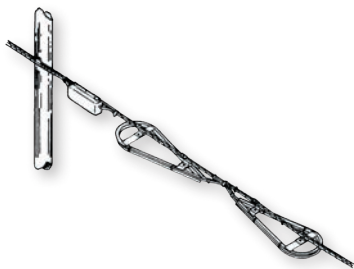

In-Line Splice

Specifications

PARAMETER	FSU-10	FSU-12	FSU-16	FSU-18	FSU-20	FSU-24
Nom. Channel Width in. (cm)	0.63 (1.60)	0.92 (2.34)	1.12 (2.84)	1.75 (4.45)	1.75 (4.45)	1.745 (4.5)
Min. Bend Diameter in. (cm)	10 (25.4)	12 (30.48)	16 (40.64)	18 (45.72)	20 (50.80)	24.125 (61.3)

PARAMETER	FOSP-12-TMK	FOSP-17-TMK
Nom. Channel Width in. (cm)	0.63 (1.59)	0.95 (2.41)
Min. Bend Diameter in. (cm)	12.13 (30.80)	17.5 (44.45)

Ordering Information

DESCRIPTION	FSU-10	FSU-12	FSU-16	FSU-18	FSU-20	FSU-24
FSU Kit	911107-00	911108-00	911109-00	911110-00	911944-00-00	FA000095

DESCRIPTION	FOSP-12-TMK	FOSP-17-TMK
FOSP Kit (Dielectric)	FA000004	FA000002

Kits contain one pair of either FSU or FOSP and four mount brackets.

Qualifications

GOVERNING BODY	STANDARD CODE
ASTM	ASTM A153, ASTM B695
Telcordia	MIL-6-5541-B

Hardware Diagram

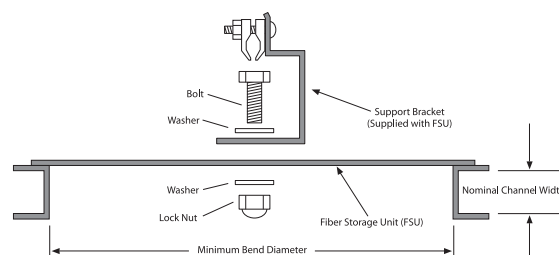



Fiber Storage Units for ADSS Fiber Optic Cable

AFL Fiber Storage Units (FSU) are used to conveniently store an extra length of cable along the ADSS cable run for later use. Furnished as pairs (kit contains two Fiber Storage Units and two sets of hanger brackets), these FSUs are constructed from UV stabilized PPE thermoplastic. All basic hardware for attachment to the ADSS cable is provided. ADSS cable mount support brackets meet Telcordia® specifications. Epoxy coated clamping devices meet ASTM specifications A153 and B695.

Features

- Small profile and side facing channel minimizes ice and leaf loading
- Constructed from UV stabilized PPE thermoplastic
- Basic hanging hardware (bolts, nuts, washers) and strand clamps all included
- Tie-wrap slots for securing cable
- Epoxy-coated strand clamps

The mounting bracket features an angled, tent-profile, epoxy-coated bracket for standard ADSS cable mounting.

Specifications

PARAMETER	FOSP-ADSS-12	FOSP-ADSS-17
Nominal Channel Width - in. (cm)	0.625	1.00
Minimum Bend Diameter - in. (cm)	12	17.5

Ordering Information

DESCRIPTION	FOSP-ADSS-12	FOSP-ADSS-17
FOS ADSS Kit	FA000049	FA000050

Kits contain one pair of FOSP and two sets of hanger brackets.

Qualifications

GOVERNING BODY	STANDARD CODE
ASTM	ASTM A153, ASTM B695

Typical Installation Diagram

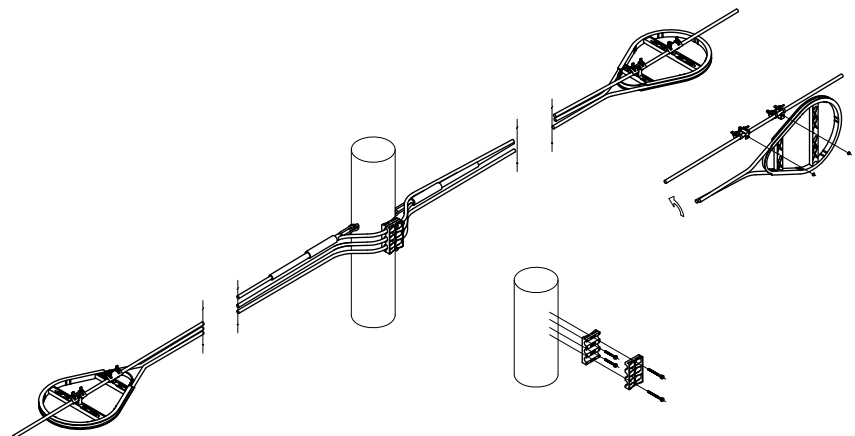



AFL TITAN RTD Multiport Terminal



AFL TRIDENT Hardened Connector

AFL TITAN RTD® FTTx System

The AFL TITAN RTD Multiport is a factory terminated OSP fiber terminal designed for quick and easy subscriber connections anywhere in the OSP network when used in conjunction with AFL TRIDENT® Hardened Fiber Optic Connectors. The sealed and rugged design of both the AFL TITAN RTD Multiport and AFL TRIDENT connector allow for long term reliability when installed anywhere in the network—underground, in pedestals, on poles, or on aerial strand or ADSS cables.

The preterminated AFL TITAN RTD Multiport Terminal is available with a variety of cable stub options. Dielectric or toneable flat drop cables are available for underground or short span self-support applications while ADSS cable stubs are available for longer span self-support applications*. Round armored cables are available for rodent protection in aerial or direct buried applications. Lastly, a pushable/air-jettable MicroDrop cable is available for microduct jetting applications.

The multiple stub options allow for flexibility when engineering the network and consolidation of multiple terminal stubs into one centralized splice point. The terminal is outfitted with four, six, eight or twelve AFL TRIDENT connector ports. The AFL TITAN RTD Multiport and AFL TRIDENT Hardened Fiber Optic Connector are designed and tested to Telcordia GR-771 and Telcordia GR-3120, respectively.

Lengths less than 350 feet ship coiled in low-profile boxes. Lengths more than 350 feet ship on a 33" corrugated plastic reel inside a cardboard box.

Features

- AFL TRIDENT Hardened Connector ports for speedy customer connections
- Stubbed with a large variety of cable options including flat drop*, ADSS*, pushable/air-jettable MicroDrop, or armored drop.
- Factory sealed for deployment in up to 10 feet of water head, but re-enterable for connector repair
- Pole and swing arm mountable; aerial mounting bracket available for strand mount
- Low profile design—4 and 6 port fit into 6" pedestals

Multiport Terminal Specifications

PARAMETER		VALUE
Dimensions (L x W x H)	4- and 6-port	12.4" x 4.9" x 3.0" 315 mm x 125 mm x 76 mm
	8- and 12-port	15.5" x 6.1" x 3.8" 394 mm x 195 mm x 96 mm
Weight	4- and 6-port	1.5 lb (0.7 kg)
	8- and 12-port	2.5 lb (1.1 kg)

AFL TRIDENT Hardened Connector Specifications

PARAMETER	VALUE
Insertion Loss, Maximum	0.50 dB
Insertion Loss, Typical	0.15 dB
Reflection	≤ -65 dB
Operating Temperature	-40°C to +75°C

Qualifications

GOVERNING BODY	STANDARD CODE
Telcordia	GR-771, GR-3120

*Refer to "AFL TITAN/TRIDENT Sag and Tension Guide" Applications Engineering Note for guidance on allowable span lengths for various stub options

AFL TITAN RTD® FTTx System



Pedestal Mount Application



AFL TITAN RTD / AFL TRIDENT® Interface

Ordering Information

RTD	12	XXX	DD	0050	F	
	Ports	Cable End	Cable Type	Tail Length	UOM	Reel
	04 = 4-port 06 = 6-port 08 = 8-port 12 = 12-port	XXX = Pigtail	DD = Dielectric Flat Drop TD = Toneable Flat Drop AD = TITAN ADSS Cable PD = Pushable MicroDrop AN = Armored Drop	*4 digits Example: 0050-F for 50 feet	F = Feet M = Meter	Blank = Standard cable-first payout R = Reversed reel, terminal-first payout

AFL TITAN RTD Accessories

DESCRIPTION	AFL NO.	IMAGE
Strand Mount Bracket Kit	FC001365	
AFL TRIDENT to SC/APC Adapter—for field replacement or jumper referencing	FC001366	
AFL TRIDENT to SC/APC Test Jumper (1 meter)	CS013775-0001	
One-Click® Cleaner SC (500 cleans)	8500-05-0001MZ	
TITAN RTD Multiport Handhole Hanging Bracket Kit, 4/6 Port	FC001474	
TITAN RTD Multiport Handhole Hanging Bracket Kit, 8/12 Port	FC001475	



AFL TRIDENT® Hardened Drop Cables

AFL TRIDENT factory-terminated drop cables are the final piece of the AFL TITAN RTD® FTTx System. The quarter-turn latching and sealing mechanism of the AFL TRIDENT connector provides quick and easy “plug and play” connections to AFL TITAN RTD multiport terminals, enabling lighting fast service subscriber connections with outstanding long term reliability. The connector/ adapter interface is keyed to ensure proper alignment of the 2.5 mm APC ferrule. Once the connector is keyed and inserted, locking and sealing is provided with a “BNC-like” quarter-turn of the connector coupling. Drops are available with one or both ends terminated (either both ends AFL TRIDENT or hybrid—one end AFL TRIDENT and one end standard SC). Drop cables are available in one, two, or four fibers (flat drop only).



Features

- AFL TRIDENT Hardened Connector ports for speedy customer connections
- Factory terminated on:
 - 250 µm outdoor or 900 µm indoor/outdoor flat drop cable
 - 250 µm armored drop
 - 900 µm pushable/air-jettable MicroDrop
- Flat drop is aerial self-support capable

Qualifications

GOVERNING BODY	STANDARD CODE
Telcordia	GR-3120

Cable Components

Dielectric OSP

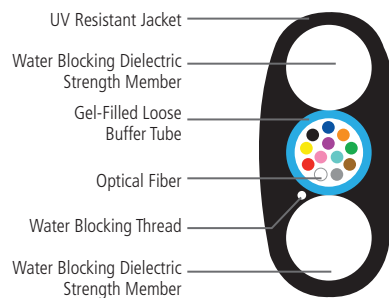

Toneable Indoor/Outdoor

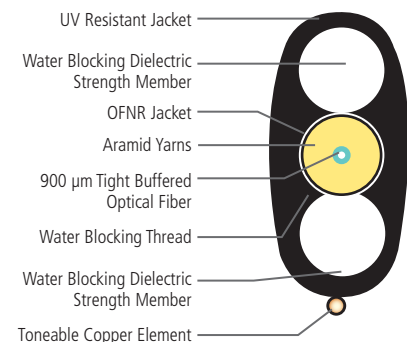

MicroDrop

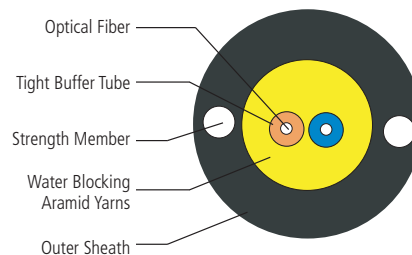

Armored Drop

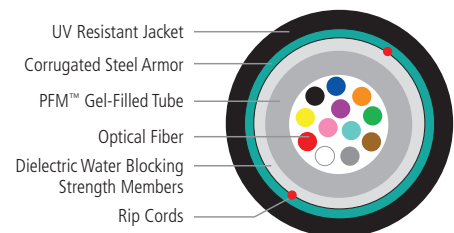

AFL TRIDENT® Hardened Drop Cables

Cable Specifications (Flat Drop Cable Only)

Max Span Length at 1% Sag	
NESC Light	550 ft (168 m)
NESC Medium	275 ft (84 m)
NESC Heavy	150 ft (46 m)

AFL TRIDENT Hardened Connector Specifications

PARAMETER	VALUE
Insertion Loss, Maximum	0.50 dB
Insertion Loss, Typical	0.15 dB
Reflection	≤ -65 dB
Operating Temperature	-40°C to +75°C
Retention Force	25 lbs (111 N)
Dust Cap Pulling Eye Tension	100 lbs (444 N)*

*One fiber only. Two or four fiber drops should not be pulled by the dust cap pulling eye.

Ordering Information

TASC	XXX	TD	001	Q	0100	F
Outside End Connector	Inside End Connector	Cable Type	Fiber Count	Fiber Type	Cable Length	UOM
XXX = No connector TASC = Trident ASC = Angle SC	XXX = No connector TASC = Trident ASC = Angle SC	DD = Dielectric Flat Drop TD = Toneable Flat Drop KTD = Toneable Indoor/Outdoor Flat Drop KDD = Dielectric Indoor/Outdoor Flat Drop AN = Armored Drop PD = Pushable MicroDrop	001 002 004	Q = Single-mode ITU-T G.652.D Z = Single-mode ITU-T G.657.A2 BIF (for I/O flat drop)	*4 digits Example: 0100F for 100 feet	F = Feet M = Meter

Please contact your AFL Sales Representative for information about our other products or services.

**FIBER OPTIC CABLE
(OPGW, ADSS, Loose Tube)**



**TEST AND INSPECTION
EQUIPMENT**



**FUSION SPLICING
SYSTEMS AND ACCESSORIES**



**FIBER OUTSIDE PLANT
EQUIPMENT**



