

TEST AND INSPECTION EQUIPMENT

OTDRs and Troubleshooters | Fiber Inspection
Cleaning | Optical Loss Testing | Fiber Identification
Test Management and Reporting Software

Founded in 1984, AFL is an international manufacturer providing end-to-end solutions to the energy, service provider, enterprise, hyperscale and industrial markets as well as several emerging markets.

AFL's products are in use in over 130 countries and include fiber optic cable and hardware, transmission and substation accessories, outside plant equipment, connectivity, test and inspection equipment, and fusion splicing systems.

AFL also offers a wide variety of services supporting data center, enterprise, wireless and outside plant applications.

AFL is dedicated to bringing our customers a quality product as well as delivering superior value.



International Sales and Service Contact Information

Available at www.AFLglobal.com/Test/Contacts

Table of Contents

OTDRs and Troubleshooters

FlexScan® FS300 Quad OTDR	3
FlexScan® FS200 Single-mode OTDR	10
FlexScan® TS100 FTTH PON Troubleshooter	16
Optical Port Saver – Field-replaceable OTDR Connector	22
OTDR Fiber Rings	24
NS and NSR Series Fiber Optic Network Simulators	28

Fiber Inspection and Cleaning

FOCIS Flex – Fiber Optic Connector Inspection System	29
FOCIS Flex No Wireless Fiber Optic Connector Inspection System	33
FOCIS Lightning®2 Multi-Fiber Optic Connector Inspection System	37
Cleaning Kits	41
CleTOP Optical Fiber Connector Cleaner	43
FCC2 Enhanced Fiber Connector Cleaner and Preparation Fluid	44
Debris Destroyer® Fiber Cleaning Pen	45
Optical Cloth Wipes	46
Push-Type Cleaners	47
One-Click® Cleaners	47
NEOCLEAN Cleaners	49
One-Click® Cleaner MMC NEW	50

Optical Loss Testing

ROGUE® OLTS Certifier	52
Multi-Fiber Switch	56
FlowScout® SE100 Single-Ended Test Set NEW	58
FlowScout® Through-Mode PON Optical Power Meter	62
Optical Loss Test Kits	65
Encircled Flux (EF) Compliant Light Sources and Test Kits	69
OLS Series Light Sources	73
Contractor Series Light Sources and Power Meters	77
OPM5 and OPM4 Optical Power Meters	81
Mandrels	85

Fiber Identification

MFIS Multi-Fiber Identification System	87
OFI-BIPM and OFI-BIPMe Optical Fiber Identifiers	91
OFI-400 Series Optical Fiber Identifiers	94
OFI-200 Optical Fiber Identifier	97
VFI4 Visual Fault Identifiers	100
MT Tracer	102

Test Management and Reporting Software

aeRos® Cloud-based Test Management and Reporting	104
TRM® 2.0/3.0 Test Results Manager	105



FlexScan® FS300 Quad OTDR

Be ready for anything with this all-in-one solution



Features

- Multimode and Single-mode OTDR, including PON test
- SmartAuto® 1-button automated testing for fast results
- Pocket-sized, weighs less than 1 pound, 12-hour battery
- LinkMap® color-coded icons for easy troubleshooting
- Integrated Source, Power Meter and VFL
- Robust reporting including Print-to-PDF
- Available with field-replaceable connector

Applications

- OTDR and insertion loss test and reporting
- Fast, accurate Pt-to-Pt and PON verification and troubleshooting
- Locate faults exceeding industry or user pass/fail thresholds
- Visually pinpoint location of macrobends or breaks

AFL's FlexScan FS300 Quad OTDR is an all-in-one solution for detecting, identifying, locating and resolving single-mode and multimode optical network issues. It is designed for both novice and expert technicians working in a range of environments from data centers to fiber-to-the-home, as well as local and wide area networks. The FlexScan FS300 automates test setup, shortens test time and simplifies results interpretation, improving efficiency and reducing costs.

All-in-one test capability: The FlexScan FS300 includes an integrated VFL, power meter and light source. It can be easily paired to AFL's award-winning FOCIS family of inspection scopes for single-fiber and/or MPO and OptiTip® multifiber inspection, ensuring technicians have everything they need to locate and resolve optical network issues.

Performance-packed: With SmartAuto automated multi-pulse acquisition, 37 dB dynamic range and best-in-class dead zones, FlexScan Quad OTDRs test multimode and single-mode networks – including FTTH PONs and POLANs up to 1:64 split ratio – while still detecting and measuring events <2 meters apart.

User-friendly: The FS300 enables both expert and novice technicians to quickly and accurately detect, locate, identify and measure optical network components and faults. It applies industry-standard or user-set pass/fail criteria and displays results using LinkMap color-coded icons that immediately show the health of the network.

Pocket-sized: The FlexScan FS300's small form factor still delivers 12-hour battery operation plus a large, bright, indoor/outdoor, 5-inch 800 x 480 touchscreen display that doesn't need a stylus.

Multiple Reporting Options: Reports can be generated directly from the unit using Print-to-PDF feature or files can be transferred wirelessly or uploaded via USB to the included Windows® compatible TRM® 3.0 Test Results Manager software.

Field-replaceable connector: With AFL's optional field-replaceable connector, avoid expensive service repairs to replace connectors damaged due to poor cleaning practices and/or normal wear-and-tear.

FlexScan® FS300 Quad OTDR

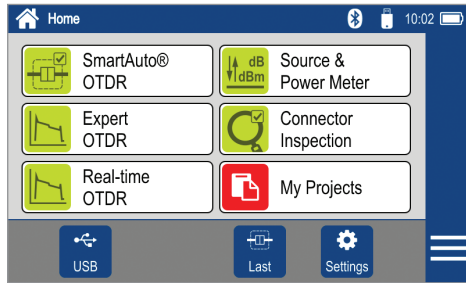

Dramatically Reduces Test Time

In SmartAuto mode, FlexScan OTDRs automatically analyze and test the network using a variety of network-optimized settings to precisely locate, characterize and identify network events with one button push. Loss and reflectance are measured for connectors, splices, splitters and macro-bends. FlexScan even checks for live fiber and verifies OTDR launch quality before initiating a test.

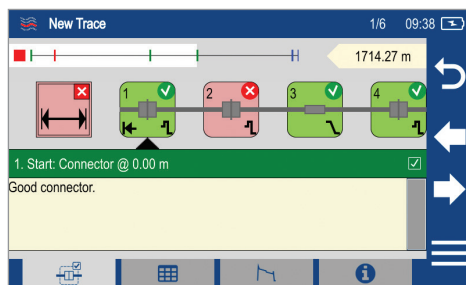

Simplifies Network Troubleshooting

LinkMap® color-coded icons enable even novice users to easily and accurately troubleshoot optical networks. LinkMap clearly identifies fiber start, end, connectors, splices, PON splitters, and macro-bends.

A LinkMap Summary provides end-to-end link length, loss and ORL. Loss and reflectance of detected events is compared to industry-standard or user-defined pass/fail thresholds and displayed with clear pass/fail indications. Users can instantly toggle between LinkMap and Trace views.

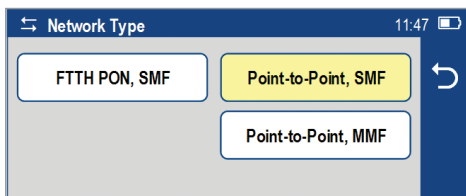

Multimode and Single-mode plus PON Testing in One OTDR

FlexScan Quad OTDRs are the ideal test tool for verifying and/or maintaining both single-mode and multimode networks. Unlike most Quad OTDRs, FS300 OTDRs test both point-to-point networks and FTTH PONs/Passive Optical LANs (POLANs).



Connectivity

FlexScan OTDRs easily pair with AFL's ward-winning FOCIS® family of connector inspection probes for fast, easy single-fiber and/or multi-fiber connector end-face inspection. Images and pass/fail results can be transferred to the FlexScan for display and/or archiving with OTDR results.

FlexScan results can be transferred wirelessly via the free FlexScan App to a smart device for real-time reporting using the included Windows-based TRM® 3.0 Test Results Manager software. Monitoring test results in real-time can detect mistakes while the tech is still in the field, preventing future truck rolls.

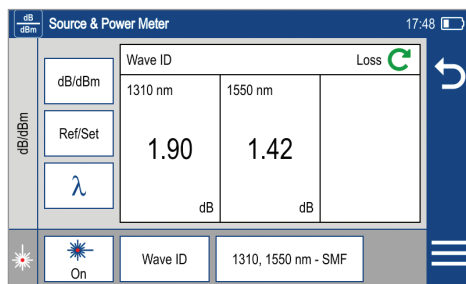

OTDR, OLTS, and VFL Testing with a Single Tool

FlexScan optionally includes a Wave ID optical light source (OLS) and optical power meter (OPM). With Wave ID, the OPM auto-synchronizes to a single or multi-wavelength Wave ID optical signal transmitted by an AFL light source. The OPM reports detected wavelengths and measures power and loss at each wavelength, saving significant test time and eliminating setup errors.

The integrated Visual Fault Locator's eye-safe red laser enables users to visually pinpoint the location of macro-bends and fiber breaks often found in splice closures and fiber cabinets.

FlexScan® FS300 Quad OTDR

Specifications^a

OTDR	MULTIMODE	SINGLE-MODE
Emitter Type	Laser	
Safety Class ^b	Class I	
Fiber Type	Multimode; compatible with OM1-OM5	Single-mode; compatible with all G.65x
Wavelengths ^c	850/1300 ±20 nm	1310/1550 ±20 nm
Network Type	Point-to-point	Point-to-point & PON up to 1:64
Connector Type	User-specified APC or UPC ferrule with interchangeable UCI adapters	
Dynamic Range ^d	≥29/29 dB @ 850/1300 nm	≥37/36 dB @ 1310/1550 nm
Event Dead Zone ^e	≤0.8 m @ 850/1300 nm typical	≤0.8 m @ 1310/1550 nm typical
Attenuation Dead Zone ^f	≤3.0 m	≤3.5 m
PON Dead Zone ^g	Not applicable	≤25 m
Pulse Widths	3, 5, 10, 20, 30, 50, 100, 200, 300, 500 ns; 1 μs	3, 5, 10, 20, 30, 50, 100, 200, 300, 500 ns; 1, 2, 3, 5, 10, 20 μs
Range Settings	250 m to 30 km	250 m to 240 km
Data Points	Up to 300,000	
Data Spacing	≥5 cm to ≤16 m	
Group Index of Refraction	1.3000 to 1.7000	
Distance Uncertainty	±(1 + 0.0025% x distance + data point spacing) m	
Linearity	±0.03 dB/dB	
Loss Resolution	0.001 dB	
Reflectance Range	850 nm: -20 to -58 dB; 1300 nm: -20 to -63 dB	1310/1550 nm: -20 to -65 dB
Reflectance Resolution	0.01 dB	
Reflectance Accuracy	±2 dB	
ORL Range	20 to 60 dB	
ORL Resolution	0.01 dB	
ORL Accuracy	±2 dB over range 30 to 55 dB; ±4 dB over range 20-30 dB and 55-60 dB	
Trace File Format	.SOR, Telcordia SR-4731 Issue 2	
OTDR Results Storage	Internal or external USB memory	
Internal Storage	Minimum 4 GB internal non-volatile memory (App SW + >5000 traces typical)	
Internal Launch Fiber	≥30 m internal MM launch fiber	≥50 m internal SM launch fiber
OTDR Modes	Supports SmartAuto, Expert, Real-Time for PON & point-to-point networks	
Real-time Refresh Rate	1 to 4 Hz	
Live Fiber Protection	No OTDR damage when connected to live fiber delivering ≤ +18 dBm at wavelength(s) in range 825 to 1675 nm	
Live Fiber Detection	Reports live fiber with input signal ≥ -35 dBm for wavelength(s) in range 825 to 1675 nm	

Notes:

- All specifications valid at 25 °C unless otherwise specified.
- FDA 21 CFR 1040.10 & 1040.11, IEC 60825-1: 2014.
- Measured with laser in CW mode at 23 °C ±3 °C.
- SNR=1, longest range and pulse width, 3 minute averaging.
- Maximum distance between two points 1.5 dB down each side of a reflective peak caused by an event with a -45 dB (or smaller) reflectance. Test pulse width is 3 or 5 ns.
- Maximum distance from the start of a trace spike caused by an event with a -45 dB (or smaller) reflectance, to the point where the trace returns to and stays within ±0.5 dB of backscatter. Test pulse width is 3 or 5 ns.
- Recovery to within 0.5 dB of backscatter after 1:16 splitter (≤13 dB loss) using 100 ns pulse width.

FlexScan® FS300 Quad OTDR

Specifications^a

OPM - OPTICAL POWER METER (P1 Option)	
Calibrated Wavelengths	850, 1300, 1310, 1490, 1550, 1625, 1650 nm
Detector Type	InGaAs PIN, 2 mm diameter
Measurement Range	+3 to -70 dBm (+3 to -65 dBm @ 850 nm)
Tone Auto-Detect	270 Hz, 330 Hz, 1 kHz, 2 kHz
Tone Detect Range	+3 to -50 dBm @1300, 1310, 1550 nm; +3 to -40 dBm @850 nm;
Wave ID	Auto-synchronizes & measures 1, 2 or 3 wavelengths
Wave ID Range	+3 to -50 dBm @1300, 1310, 1550 nm; +3 to -40 dBm @850 nm
Accuracy	±5% @ -10 dBm
Linearity	±0.1 dB (-3 to -40 dBm); ±0.25 dB (-40 to -70 dBm)
Resolution	0.01 dB
Measurement Units	Power in dBm, nW, µW, mW; Loss in dB

OLS - OPTICAL LIGHT SOURCE (P1 Option)	
Wavelengths	850/1300/1310/1550 nm
Emitter Type	Laser
Safety Class	Class I ^b
Launch Condition	Controlled Launch at 850 nm (comparable to encircled flux on OM4 fiber)
Center λ (CW Mode)	±20 nm
Spectral Width	5 nm maximum (FWHM, CW Mode)
Internal Modulation	270 Hz, 330 Hz, 1 kHz, 2 kHz, CW, Wave ID
SM Output Stability	Short-term ^c : ±0.1 dB; Long-term ^d : ±0.05 dB
MM Output Stability	Short-term ^e : ±0.20 dB; Long-term ^f : ±0.15 dB
Output Power	1310/1550 nm: -7 dBm ±1.5 dB (CW, G.652.C/D) 1300 nm: -7 dBm ±1.5 dB (CW, 50 µm MMF) 850 nm: 0 dBm ±1.5 dB (CW, 50 µm MMF)

VFL - VISUAL FAULT LOCATOR	
Emitter Type	Laser, Class IIIa / Class 3R ^b
Wavelength	635 nm ±10 nm
Output Power	1.5 mW (~+2 dBm ±0.5 dB) into SMF-28
Modes	CW and 1 Hz flashing

Notes:

- a. All specifications valid at 25 °C unless otherwise specified.
- b. FDA 21 CFR 1040.10 and 1040.11, and IEC 60825-1:2014.
- c. Typical maximum deviation over 15 minute after 15 minute warm-up.
- d. Typical maximum deviation over 8 hours after 1 hour warm-up.
- e. 15 minutes after 30 minutes warm-up.
- f. 8 hours after 1 hour warm-up.

GENERAL	
Size (in boot)	98 x 175 x 52.5 mm
Weight	0.8 kg
Operating Temperature	-10 °C to +50 °C, 0 to 95% RH (non-condensing)
Storage Temperature	-30 °C to +70 °C, 0 to 95% RH (non-condensing, battery removed) -20 °C to +60 °C, 0 to 95% RH (non-condensing, battery installed)
Power	Rechargeable Lithium polymer battery; AC adapter
AC Adapter	100-240 VAC, 50-60 Hz input; 5VDC, 2A output
Battery Life (OTDR)	≥12 hours, Telcordia test conditions, 4 hours recharge
Display	5-inch color LCD, 800 x 480 pixels, backlit
Shock and Vibration	GR-196-CORE, drop test, 0.75 m (30 in.), 6 planes
Dust Protection	GR-196-CORE, rubber dust caps for all ports
OTDR/OLS Ports	MM: UPC; SM: UPC or APC; includes tool-free, interchangeable SC adapters
OPM and VFL Ports	Universal, 2.5 mm adapter (SC, FC, ST); others available
USB Ports	USB host port; micro-USB function port
Bluetooth Interface	W1 option; compatible with Windows PC and Android
WiFi Interface	W1 option; compatible with IEEE 802.11 / WLAN
CE Safety	Compliant with EN61010-1
CE EMI/RFI	EN55011, EN61326-1, GR-196-CORE 4.5.1
RoHS	Compliant with RoHS directive 2011/65/EU

FlexScan® FS300 Quad OTDR

FlexScan FS300 models are available in five kit configurations: Basic, PLUS, PRO, BIPM, and MPO. All kits include FS300 with AC charger, battery, carry strap, SC/2.5 mm connector adapters, TRM® 3.0, quick reference user guide, and carry case.

Ordering Information

FS300-325 Basic, Plus, PRO, BIPM kits Order Entry: **FS300-325-[KIT]-[Pn]-[Wn]-[C]-[CC]-[LNG]-[AC]-[SMFR]-[MMFR]-[TIP]**

FS300-325 MPO kits (SMF and MMF) Order Entry: **FS300-325-[MKIT]-P1-[Wn]-[LNG]-[AC]-[MPOC]** where:

[KIT]	FS300 FlexScan Kit Configuration
BAS	Includes: FS300, soft case, TRM® 3.0 Basic, USB cable ^a
PLUS	Includes: BAS kit plus 150 m SMF & MMF Fiber Rings, One-Click Cleaner, upgrade to TRM 3.0 Advanced, user-selected soft or hard carry case
PRO	Includes: PLUS kit plus FOCIS Flex with two user-selected adapter tips
BIPM	Includes: PRO kit plus OFI-BIPMe

[MKIT]	FS300-325 MPO Kit Configuration
SMPO	SMF MPO test kit; Includes SMF MPO switch, launch cables, carry case
MMPO	MMF MPO test kit; Includes MMF MPO switch, launch cables, carry case

[PN]	OPTICAL LIGHT SOURCE (OLS) and Optical Power Meter (OPM)
P0	No OLS, no OPM
P1	850/1300 MM; 1310/1550 SM Source and Power Meter

[WN]	Bluetooth/WiFi Configuration
W0	No Bluetooth or WiFi
W1^b	Includes WiFi and Bluetooth

[C]	OTDR / Source Connector Type
A	APC (recommended)
U	UPC

[CC] ^c	Carry Case Option
S1	Standard soft case for FlexScan, Fiber Rings, FOCIS Flex, accessories (Basic, PLUS, PRO kits only)
S2	Large soft case for FlexScan, Fiber Rings, FOCIS Flex, OFI-BIPMe, accessories (PLUS, PRO, BIPM kits only)
H1	Hard carry case (PLUS, PRO, BIPM Kits only)

[LNG]	Language
ENG	English
CHS	Chinese Simp.
CHT	Chinese Trad.
CZE	Czech
DEU	German
DNK	Danish

[LNG]	Language
FIN	Finnish
FRA	French
ITA	Italian
JPN	Japanese
KOR	Korean
NOR	Norwegian

[LNG]	Language
POL	Polish
POR	Portuguese
SPA	Spanish
TUR	Turkish
VNM	Vietnamese

[AC]	Destination Country	AC Plugs
US	USA	2-pin, US
EU	European Union	2-pin, EU
UK	United Kingdom	3-pin, UK
CN	China, Australia	2-pin, SAA

Notes:

- Results can be transferred from FlexScan to TRM® 3.0 using USB cable, or performed wirelessly (W1 option) after downloading FlexScan App from 'Google play' or 'App Store'.
- FlexScans equipped with Bluetooth option (W1) support Bluetooth transfer of results via FlexScan App for remote reporting using TRM 3.0.
- Basic kit always ships with S1 (Standard Soft Case); MPO kit always ships with MPO-specific soft case.

[SMFR]	150 m SMF Fiber Ring
Absent	N/A in Basic kits
USC/USC	FR-SMF-150-USC-USC
USC/UFC	FR-SMF-150-USC-UFC
USC/ULC	FR-SMF-150-USC-ULC
USC/UST	FR-SMF-150-USC-UST
USC/ASC	FR-SMF-150-USC-ASC
USC/AFC	FR-SMF-150-USC-AFC
USC/ALC	FR-SMF-150-USC-ALC
USC/UE2	FR-SMF-150-USC-UE2
ASC/UFC	FR-SMF-150-ASC-UFC
ASC/ULC	FR-SMF-150-ASC-ULC
ASC/UST	FR-SMF-150-ASC-UST
ASC/ASC	FR-SMF-150-ASC-ASC
ASC/AFC	FR-SMF-150-ASC-AFC
ASC/ALC	FR-SMF-150-ASC-ALC
ASC/AE2	FR-SMF-150-ASC-AE2

[MMFR]	150 m OM1 (62.5 μm) Fiber Ring
Absent	N/A in Basic kits
USC/UST1	FR-OM1-150-USC-UST
USC/USC1	FR-OM1-150-USC-USC
USC/ULC1	FR-OM1-150-USC-ULC
USC/UFC1	FR-OM1-150-USC-UFC

[MMFR]	150 m OM2 (50 μm) Fiber Ring
Absent	N/A in Basic kits
USC/UST2	FR-OM2-150-USC-UST
USC/USC2	FR-OM2-150-USC-USC
USC/ULC2	FR-OM2-150-USC-ULC
USC/UFC2	FR-OM2-150-USC-UFC

[MMFR]	150 m OM3/4/5-compatible Fiber Ring
Absent	N/A in Basic kits
USC/UST3	FR-OM3-150-USC-UST
USC/USC3	FR-OM3-150-USC-USC
USC/ULC3	FR-OM3-150-USC-ULC
USC/UFC3	FR-OM3-150-USC-UFC

[TIP]	FOCIS Flex Tips and Cleaning (PRO only)
Blank	Option not available in Basic and PLUS kits
SC	SC-UPC bulkhead tip, 2.5 mm UPC ferrule tip, 2.5 mm One-Click
FC	FC-UPC bulkhead tip, 2.5 mm UPC ferrule tip, 2.5 mm One-Click
LC	LC-UPC bulkhead tip, 1.25 mm UPC ferrule tip, 1.25 mm One-Click
ASC	SC-APC bulkhead tip, 2.5 mm APC ferrule tip, 2.5 mm One-Click
AFC	FC-APC bulkhead tip, 2.5 mm APC ferrule tip, 2.5 mm One-Click
ALC	LC-APC bulkhead tip, 1.25 mm APC ferrule tip, 1.25 mm One-Click

[MPOC]	MPO Launch Cable Network Connector
F	Female (unpinned)
M	Male (pinned)

FlexScan® FS300 Quad OTDR

Ordering Information (continued)

Accessories

DESCRIPTION	AFL NO.
FlexScan wrist strap	1400-05-0230PZ
FlexScan neck strap, 36"	1400-05-0231PZ
AC charger 100-240 VAC to 5 VDC	4050-00-0931PR
Soft carry case for FS300 with FOCIS, OFI, and Fiber Ring	1400-01-0167PZ
Soft carry case for FS300-325 MPO kits	1400-20-0001PZ
Soft carry case for FS300 with FOCIS, and Fiber Ring	1400-20-0002PZ
Hard carry case for FS300 kits with FOCIS, OFI, and Fiber Ring	1400-01-0177PZ
FS300 extended temperature replacement battery	3900-06-0902MR
Vehicle charger, 12VDC to 5VDC @2A	4050-00-0033MR
Cable, USB-micro B, 5 pin, 6'	6000-00-0031MR
5V USB charging cable (1.5 m), type A to barrel (0.9 X 3.2 X 9 mm)	6000-00-0034PR
One-Clicks, fluid, wipes, etc. See www.AFLglobal.com	Cleaning Supplies

Field-Replaceable OTDR Connector (Optical Port Ferrule Saver)

Protect your OTDR ports from damage due to mating with dirty or damaged launch cables or patch cords or normal wear-and-tear. Equip your FlexScan FS300 with a field-replaceable connector, which installs in seconds and accepts AFL's tool-free interchangeable SC, LC, FC and ST connector adapters.

Replace damaged connectors in the field: When normal wear-and-tear or poor cleaning practices damage the port saver's end-face, replace it in seconds without having to return the OTDR to a service center for an expensive and time-consuming repair.

DESCRIPTION	AFL NO.
Field-replaceable connector; APC female to APC male	2900-58-0001MR
Field-replaceable connector; APC female to UPC male	2900-58-0002MR
Field-replaceable connector; UPC female to APC male	2900-58-0003MR
Field-replaceable connector; UPC female to UPC male	2900-58-0004MR

Connector Adapters

CONNECTOR ADAPTER	AFL NO.		
	OTDR/OLS PORT	OPM PORT	VFL PORT
FC	2900-50-0002MR	2900-52-0001MR	N/A
SC	2900-50-0003MR	2900-52-0002MR	N/A
ST	2900-50-0004MR	2900-52-0003MR	N/A
LC	2900-50-0006MR	2900-52-0004MR	N/A
SC/APC	2900-50-0011MR	N/A	N/A
2.5 mm Universal	N/A	2900-52-0005MR	2900-50-0007MR
1.25 mm Universal	N/A	2900-52-0006MR	2900-50-0010MR

FlexScan® FS300 Quad OTDR

Test Management and Reporting Software

DESCRIPTION	AFL NO.
TRM® 3.0 with Basic License (OTDR Trace/OLTS Viewer, Batch Editor and Reports), USB delivery (included with all FS300 kits)	TRM3-BASIC
TRM 3.0 upgrade from Basic to Advanced License, USB delivery	TRM3-UPGRADE
TRM 3.0 upgrade from Basic to Advanced License, email delivery	TRM3-UP-EMAIL
FlexScan App (Android Google play)	Free Download

Recommended Products



FOCIS Flex and FOCIS Lightning (Multi-Fiber) Connector Inspection

- Self-contained, tether-free, hand-held inspection solution
- Auto-focus and auto-centering for fast, easy inspection
- IEC, IPC and user-defined pass/fail analysis
- FOCIS Lightning: extremely fast multi-fiber auto-analysis for datacom and telecom inspection applications



OFI-BIPMe Optical Fiber Identifier

- World class signal sensitivity
- Trigger lock, positive stop for optimum detection
- Integrated optical power meter option

Qualifications

CATEGORY	REGULATION/STANDARD	QUALIFICATION
CE Marking	EU	Compliant to relevant EU Directives on health, safety, and environmental protection, and certified with CE marking
Safety/EMC/EMI	IEC	Compliant to IEC 61010-1 for safety requirements for electrical equipment
	EN	Compliant to EN 61010-1 for safety requirements for electrical equipment
	IEC	Compliant to IEC 61326-1 for EMC requirements for electrical equipment
	EN	Compliant to EN 61326-1 for EMC requirements for electrical equipment
	EN	Compliant to EN 55011 for EMC requirements for industrial, scientific and medical equipment
	Telcordia	Compliant to GR-196-CORE 4.5.1 for requirements on electromagnetic interference
	FCC	Compliant to code of federal regulations FCC 47 CFR 15 on unlicensed transmissions
	FDA	Compliant to code of federal regulations FDA 21 CFR 1040.10 and 1040.11 on laser products
RoHS	IEC	Compliant to IEC 60825-1 for safety of laser products
	EU	Compliant to EU regulations Directive 2011/65/EU (RoHS 2) and Directive 2015/863 (RoHS 3)
Test Method	TIA	Compliant to TIA-568.3-D for test and measurement requirements for premises optical fiber cabling and components
	IEC	Compliant to IEC 11801 for test and measurement requirements for optical fiber cabling for use within premises
	AS/NZS	Compliant to AS/NZS 3080 for test and measurement requirements for optical fiber cabling for use within premises
	TIA	Compliant to TIA-526-7 for test procedures for installed optical fiber cable plant
	TIA	Compliant to TIA-526-14 for test procedures for installed optical fiber cable plant
	IEC	Compliant to IEC 14763-3 for systems and methods for the inspection and testing of installed optical fiber cabling
	AS/NZS	Compliant to AS/NZS 14763.3 for systems and methods for the inspection and testing of installed optical fiber cabling
	IEC	Compliant to IEC 61280-4-1 for test procedures for installed optical fiber cable plant
Generic Requirement	IEC	Compliant to IEC 61280-4-2 for test procedures for installed optical fiber cable plant
	Telcordia	Compliant to GR-196-CORE for generic requirements for OTDR-type equipment
	Telcordia	Compliant to SR-4731 Issue 2 for OTDR data format
	IEC	Compliant to IEC 61746-1 for requirements on calibration of OTDR

Contact Sales@AFLglobal.com to schedule a demonstration or learn how to buy.

Visit www.AFLglobal.com/Test to learn more about FlexScan FS300 OTDR.

International Sales and Service Contact Information available at www.AFLglobal.com/Test/Contacts

FlexScan® FS200 Single-mode OTDR

Pocket-sized, Performance-packed, User-friendly, and Affordable



Features

- Flexpress® mode completes OTDR tests in <5 seconds
- Test up to 1:64 PON with 25 m PON dead zone
- Easy to understand LinkMap® results with pass/fail indications
- Single, dual or triple wavelength single-mode
- Single port for in- and out-of-service OTDR tests
- Integrated source, power meter, VFL (visual fault locator)
- Integrated MPO Switch control via USB
- Rugged, lightweight, hand-held for field use
- Available with field-replaceable Port Saver connector

Applications

- PON or point-to-point network verification or troubleshooting
- OTDR testing plus insertion loss and power measurements
- Locate faults exceeding industry or user pass/fail thresholds
- Visually pinpoint location of macro-bends or breaks

AFL's FlexScan FS200 OTDR is an all-in-one solution for detecting, identifying, locating, and resolving single-mode optical network issues. It is designed for both novice and expert technicians working in a range of environments, from FTTH PON to point-to-point networks. It applies industry-standard or user-set pass/fail criteria and displays results using LinkMap color-coded icons to show the health of the network. FlexScans automate test setup, shorten test time, and simplify results interpretation improving efficiency and reducing costs.

All-in-one test capability: The FlexScan FS200 includes an integrated VFL, power meter, and light source. It can be easily paired to AFL's award-winning FOCIS family of inspection scopes, ensuring technicians have everything they need to locate and quickly resolve optical network issues.

Performance-packed: With SmartAuto multi-pulse acquisition, up to 37 dB dynamic range, and best-in-class 25 m PON dead zone, FlexScan FS200 PON OTDRs test FTTH PONs up to 1:64 while still detecting and measuring events only meters apart.

Fast! Flexpress mode completes dual-wavelength tests in <5 seconds – 10 x faster than conventional OTDRs! For multi-fiber testing, FS200s automatically control AFL's MFS Multi-Fiber Switch (12-fiber MPO switch) to further reduce multi-fiber test time.

Pocket-sized: At 3.5 x 6 x 1.75 in. (86 x 160 x 43 mm) and less than one pound (0.4 kg), FlexScan FS200 OTDRs truly fit in your pocket, yet still provide a large, bright indoor/outdoor touchscreen display, and all-day operation.

Multiple sharing and reporting options: Results can be stored internally, saved to a USB, and uploaded via USB cable, Bluetooth (via FlexApp) or Wi-Fi for real-time reporting using the included FlexReports Test Results Manager software.

Convenient cost-saving kits: Bundle the FlexScan FS200 with your choice of launch cable, FOCIS Flex connector inspection probe and tips, and/or AFL's universal optical fiber identifier (OFI-BIPMe) for significant cost-savings!

PON-optimized FTTH-PRO kits combine FS200-303/304 with a FOCIS Flex Inspection probe, 4 adapter tips, and launch cables for both SC-APC and LC-APC networks.

Field-replaceable Port Saver connector: With AFL's optional field-replaceable Port Saver, avoid expensive service repairs to replace connectors damaged due to poor cleaning practices and/or normal wear-and-tear.

FlexScan® FS200 Single-mode OTDR

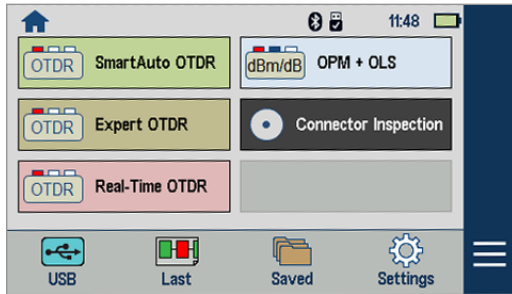

Dramatically Reduces Test Time

In SmartAuto mode, FlexScan OTDRs automatically analyze and test the network using a variety of network-optimized settings to precisely locate, characterize and identify network events with one button push. Loss and reflectance are measured for connectors, splices, splitters and macro-bends. FlexScan even checks for live fiber and verifies OTDR launch quality before initiating a test.

FlexScan's Flexpress mode completes dual-wavelength tests in seconds, reducing test time by 10x compared to conventional OTDRs. For multi-fiber testing, FlexScan's automatically control AFL's MPO Switch, testing 12 fibers at the touch of a single button.

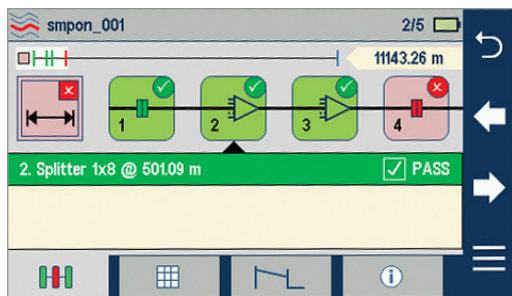

Simplifies Network Troubleshooting

LinkMap with pass/fail enables even novice users to easily and accurately troubleshoot optical networks. LinkMap presents an icon-based view of the tested network clearly identifying fiber start, end, connectors, splices, PON splitters, and macro-bends.

A LinkMap summary provides end-to-end link length, loss and ORL. Loss and reflectance are displayed with clear pass/fail indications. Users can instantly toggle between LinkMap and Trace views.



Connectivity

FlexScan OTDRs easily pair with AFL's award-winning FOCIS® family of connector inspection probes for fast, easy single-fiber and/or multi-fiber connector end-face inspection.

FlexScan results can then be transferred via USB cable, Wi-Fi, or Bluetooth and the free FlexApp running on a mobile device for real-time reporting using the included FlexReports Test Results Manager PC-based software. This real-time monitoring can help avoid mistakes in the field that will require future truck rolls.

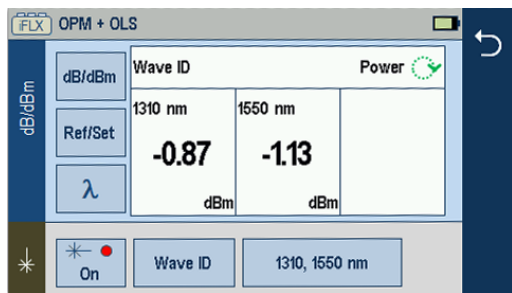

OTDR, OLTS, and VFL Testing with a Single Tool

FlexScan optionally includes a Wave ID optical light source (OLS) and optical power meter (OPM). With Wave ID, the OPM auto-synchronizes to a single or multi-wavelength Wave ID optical signal transmitted by an AFL light source. The OPM reports detected wavelengths and measures power and loss at each wavelength, saving significant test time and eliminating setup errors.

The integrated VFL's eye-safe red laser enables users to visually pinpoint the location of macro-bends and fiber breaks often found in splice closures and fiber cabinets.

FlexScan® FS200 Single-mode OTDR

FlexScan OTDRs are available with 1310/1550/1625, 1310/1550/1650, 1310/1550, and 1650 nm only wavelengths. The 1310 and 1550 nm versions are available with integrated optical light source (OLS), optical power meter (OPM), visual fault locator (VFL) and Bluetooth/Wi-Fi.

Specifications^a

MODEL: FS200-XXX	-60	-100	-300	-303	-304
OTDR					
Emitter Type	Laser				
Safety Class ^b	Class I				
Fiber Type	Single-mode				
Wavelengths (nm)	1650	1310/ 1550	1310/ 1550	1310/ 1550/ 1625	1310/ 1550/ 1650
Center λ Tolerance ^c	1310/1550/1650: ± 20 nm; 1625 +30/-5 nm				
Dynamic Range ^d (dB)	37	32/30	37/35	37/35/37	37/35/37
Event Dead Zone ^e (m)	0.8	0.8	0.8	0.8	0.8
Atten. Dead Zone ^f (m)	3.5	3.6	3.5	3.5	3.5
PON Dead Zone ^g (m)	30	N/A	25/25	25/25/40	25/25/40
Max Split Ratio	1:64 (FS200-60/30x only); N/A (FS200-100)				
Pulse Widths	3, 5, 10, 20, 30, 50, 100, 200, 300, 500 ns; 1, 2, 3, 10 μs; 20 μs (FS200-300/300/304 only)				
Range Settings	250 m to 240 km				
Data Points	Up to 300,000 (Expert mode .SOR file)				
Data Spacing	5 cm to 16 m				
Index of Refraction	1.3000 to 1.7000				
Distance Uncertainty	±(1 + 0.003% x distance + data point spacing) m				
Linearity (dB/dB)	±0.05				
Trace File Format	Telcordia SR-4731 Issue 2 compatible .SOR				
Trace Storage Medium	4 GB internal memory (> 5000 traces typical); External USB memory stick				
Data Transfer to PC	USB cable or Bluetooth® (option)				
OTDR Modes	SmartAuto, Expert, Real-time				
Flexpress Fast Test	FS200-300/303/304				
Display Modes	LinkMap Summary, LinkMap Events, Trace				
Refresh Rate	Up to 4 Hz (Real-time mode)				
Live Fiber Protection	No OTDR damage with input power ≤ +20 dBm for wavelength(s) in range 1260 to 1675 nm				
Live Fiber Detection	Reports live fiber with input signal ≥ -35 dBm for wavelength(s) in range 1260 to 1675 nm				
PON Filter Isolation	>50 dB for 1260 nm ≤ wavelength ≤ 1600 nm				
Live PON OTDR Test	1625 or 1650 nm using filtered detector when interfering downstream power in range 1600-1675 nm <-38 dBm				

Notes:

- All specifications valid at 25 °C unless otherwise specified.
- FDA 21 CFR 1040.10 & 1040.11, IEC 60825-1: 2014.
- Using 10 ns pulse width.
- SNR=1, longest range and pulse width, 3-minute averaging.
- Maximum distance between two points 1.5 dB down each side of a reflective peak caused by an event with reflectance ≤ -45 dB using 3 or 5 ns pulse.
- Maximum distance from the start of a trace spike caused by an event with a -45 dB (or smaller) reflectance, to the point where the trace returns to and stays within ±0.5 dB of backscatter. Test pulse width is 3 or 5 ns.
- Recovery to within 0.5 dB of backscatter after 1:16 splitter (≤13 dB loss) using 50 ns pulse width.
- Max temperature while charging is +45 °C.

MODEL: FS200-XXX	-60	-100	-300	-303	-304
VISUAL FAULT LOCATOR (VFL)					
Emitter Type	Visible red laser, 650 ±20 nm				
Safety Class ^b	Class II				
Output Power	0.8 mW into single-mode fiber (-1 dBm ±0.5 dB)				
Modes	CW, 2 Hz flashing				
OPTICAL LASER SOURCE - OLS (Optional)					
Emitter Type	Laser				
Safety Class ^b	Class I				
Fiber Type	Single-mode				
Wavelengths (nm)	N/A	1310/ 1550	1310/ 1550	1310/ 1550	1310/ 1550
Center λ Tolerance	±20 nm (CW mode)				
Spectral Width (FWHM)	5 nm (maximum)				
Internal Modulation	270 Hz, 330 Hz, 1 kHz, 2 kHz, CW, Wave ID				
Wave ID	Compatible with AFL OPM/OLS				
Output Power Stability	≤ ±0.1 dB (15 minutes); ≤ ±0.15 dB (8 hours)				
Output Power	-3 dBm ±1.5 dB				
OPTICAL POWER METER -OPM (Optional)					
Calibrated Wavelengths	1310, 1490, 1550, 1625, 1650 nm				
Detector Type	InGaAs, 1 mm diameter				
Measurement Range	+23 to -50 dBm				
Tone Detect Range	+3 to -35 dBm				
Accuracy	±0.25 dB				
Resolution	0.01 dB				
Measurement Units	dB, dBm or Watts (nW, μW, mW)				
GENERAL					
Size (in boot)	86 x 160 x 43 mm				
Weight	0.4 kg				
Operational Temperature ^h	-10 °C to +50 °C, 0 to 95 % RH (non-condensing)				
Storage Temperature	-40 °C to +70 °C, 0 to 95 % RH (non-condensing)				
Power	Rechargeable Li-Pol or AC adapter				
Battery Life	>12 hours, Telcordia test conditions				
Display	4.3 in color touchscreen LCD, 480x272, backlight				
USB Ports	1 host; 1 micro-USB function				
Bluetooth (optional)	Compatible with Windows PC, Android, iOS				
Wi-Fi	Download results & update software via IEEE 802.11 Wi-Fi				

FlexScan® FS200 Single-mode OTDR

Ordering Information

All kits include a FlexScan FS200 with AC charger, battery, carry strap, SC/2.5 mm connector adapters, FlexReports, USB cable, and carry case.

FS200-XXX-Basic, Plus, PRO, BIPM Kits Order Entry: **FS200-[MOD]-[KIT]-[PW]-[C]-[CC]-[LNG]-[AC]-[FR]-[TIP]**

FS200-XXX-MPO Kits Order Entry: **FS200-[MOD]-MPO-P1-W1-[C]-[LNG]-[AC]-[MPOC]**

FS200-303/304-FTTH PRO Kits Order Entry: **FS200-[MOD]-FTTH-PRO-[CC]-[LNG]-[AC]** where:

[MOD]	FS200 FlexScan OTDR Configuration
60	1650 nm filtered Live PON Troubleshooting OTDR
100	1310/1550 nm Verification and Troubleshooting OTDR
300	1310/1550 Pt-to-Pt & PON Verification and Troubleshooting OTDR
303	1310/1550/1625 Pt-to-Pt and PON Verification and Troubleshooting OTDR
304	1310/1550/1650 Pt-to-Pt and PON Verification and Troubleshooting OTDR

[KIT]	FS200 FlexScan Kit Configuration / Kit Contents
BAS	Includes: FS200, FlexReports Basic, USB cable ^a , soft case
PLUS	Includes: BAS Kit plus 150 m SMF Fiber Ring, One-Click Cleaner, upgrade to FlexReports Advanced, soft or hard carry case
PRO	Includes: PLUS Kit plus FOCIS Flex with two user-selected adapter tips
FTTH-PRO	Includes: BAS Kit, 150 m SC/APC & LC/APC Fiber Rings, FOCIS Flex, SC/APC & LC/APC bulkhead and ferrule adapters, SC & LC One-Click Cleaners, Port Saver, FlexReports Advanced, soft or hard carry case (FS200-303/304 only)
BIPM	Includes: PRO Kit plus OFI-BIPMe
MPO	Includes: FlexScan plus MFS Multi-Fiber Switch, MPO launch cable, OTDR-to-Switch patch cord, OTDR-to-Switch USB cable, FlexReports Advanced

[PW]	Power Meter / Wireless Option
P0-W0	No Source, Power Meter, or Bluetooth/WiFi (FS200-60/100 only)
P0-W1 ^b	No Source or Power Meter; Includes Bluetooth/WiFi (FS200-300/304 only)
P1-W0	No Bluetooth/WiFi (-303/304 only); Includes Source, Power Meter
P1-W1 ^b	Includes Source, Power Meter, Bluetooth/Wi-Fi

[C]	OTDR / Source Connector Type
A	APC (recommended)
U	UPC (available in all models except FS200-60)

[CC] ^c	Carry Case Option (PLUS, PRO, FTTH-PRO, BIPM Kits)
S1	Large soft case for FS200, fiber ring, FOCIS Flex, OFI-BIPMe, accessories
S2	Medium soft case for FS200, fiber ring, FOCIS Flex, accessories
H1	Hard carry case for FS200, fiber ring, FOCIS Flex, OFI-BIPMe, accessories

[LNG]	Language
ENG	English
CHS	Chinese Simplified
CHT	Chinese Traditional
CZE	Czech
DEU	German
DNK	Danish
FIN	Finnish
FRA	French
ITA	Italian

[LNG]	Language
JPN	Japanese
KOR	Korean
NOR	Norwegian
POL	Polish
POR	Portuguese
SPA	Spanish
TUR	Turkish
VNM	Vietnamese

[AC]	Destination Country	AC Plugs
US	USA	2-pin, US
EU	European Union	2-pin, EU
UK	United Kingdom	3-pin, UK
CN	China, Australia	2-pin, SAA

[FR]	150 m SMF Fiber Ring
Absent	N/A in Basic Kits
USC/USC	FR-SMF-150-USC-USC
USC/UFC	FR-SMF-150-USC-UFC
USC/ULC	FR-SMF-150-USC-ULC
USC/UST	FR-SMF-150-USC-UST
USC/ASC	FR-SMF-150-USC-ASC
USC/AFC	FR-SMF-150-USC-AFC
USC/ALC	FR-SMF-150-USC-ALC
USC/UE2	FR-SMF-150-USC-UE2
ASC/UFC	FR-SMF-150-ASC-UFC
ASC/ULC	FR-SMF-150-ASC-ULC
ASC/UST	FR-SMF-150-ASC-UST
ASC/ASC	FR-SMF-150-ASC-ASC
ASC/AFC	FR-SMF-150-ASC-AFC
ASC/ALC	FR-SMF-150-ASC-ALC
ASC/AE2	FR-SMF-150-ASC-AE2

[TIP]	FOCIS Flex Tips and Cleaning (PRO only)
Blank	Option not available in Basic & PLUS Kits
SC	SC-UPC bulkhead tip, 2.5 mm UPC ferrule tip, 2.5 mm cleaning
FC	FC-UPC bulkhead tip, 2.5 mm UPC ferrule tip, 2.5 mm cleaning
LC	LC-UPC bulkhead tip, 1.25 mm UPC ferrule tip, 1.25 mm cleaning
ASC	SC-APC bulkhead tip, 2.5 mm APC ferrule tip, 2.5 mm cleaning
AFC	FC-APC bulkhead tip, 2.5 mm APC ferrule tip, 2.5 mm cleaning
ALC	LC-APC bulkhead tip, 1.25 mm APC ferrule tip, 1.25 mm cleaning

[MPOC]	MPO Launch Cable Network Connector
F	Female (unpinned) to Female (unpinned)
M	Female (unpinned) to Male (pinned)

Notes:

- Results can be transferred from FlexScan OTDR to FlexReports using USB cable, or performed wirelessly (W1 option) after downloading free FlexApp. The FlexApp is available as a free download from 'Google play' or 'App Store'.
- FlexScans equipped with Bluetooth option (W1) support Bluetooth transfer of results via FlexApp for remote reporting using FlexReports.
- Basic Kit always ships with S2 (Medium Soft Case); MPO Kit always ships with MPO-specific soft case.

FlexScan® FS200 Single-mode OTDR

Ordering Information

Accessories

DESCRIPTION	AFL NO.
FlexScan wrist strap	1400-05-0230PZ
FlexScan neck strap, 36"	1400-05-0231PZ
AC charger 100-240 VAC to 5 VDC	4050-00-0931PR
Soft carry case for FS200 kits with FOCIS Flex and Fiber Ring	1400-01-0111PZ
Soft carry case for FS200 kits with FOCIS Flex, OFI-BIPMe and Fiber Ring	1400-01-0128PZ
Hard carry case for FS200 kits with FOCIS Flex, OFI-BIPMe and Fiber Ring	1400-01-0134PZ
Vehicle charger, 12VDC to 5VDC @2A	4050-00-0033MR
Cable, USB-micro B, 5 pin, 6'	6000-00-0031MR
5V USB charging cable (1.5 m), type A to barrel (0.9 X 3.2 X 9 mm)	6000-00-0034PR
One-Clicks, fluid, wipes, etc. See www.AFLglobal.com	Cleaning Supplies

Field-Replaceable OTDR Connector (Optical Ferrule Port Saver)

Protect your OTDR ports from damage due to mating with dirty or damaged launch cables or patch cords or normal wear-and-tear. Equip your FlexScan FS200 with a field-replaceable connector, which installs in seconds and accepts AFL’s tool-free interchangeable SC, LC, FC and ST connector adapters.

Replace damaged connectors in the field: When normal wear-and-tear or poor cleaning practices damage the port saver’s end-face, replace it in seconds without having to return the OTDR to a service center for an expensive and time-consuming repair.

DESCRIPTION	AFL NO.
FlexScan-facing APC female to APC male field-replaceable Port Saver connector	2900-58-0001MR
FlexScan-facing APC female to UPC male field-replaceable Port Saver connector	2900-58-0002MR
FlexScan-facing UPC female to APC male field-replaceable Port Saver connector	2900-58-0003MR
FlexScan-facing UPC female to UPC male field-replaceable Port Saver connector	2900-58-0004MR

Connector Adapters

CONNECTOR ADAPTER	AFL NO.		
	OTDR/OLS PORT	OPM PORT	VFL PORT
FC	2900-50-0002MR	2900-52-0001MR	N/A
SC	2900-50-0003MR	2900-52-0002MR	N/A
ST	2900-50-0004MR	2900-52-0003MR	N/A
LC	2900-50-0006MR	2900-52-0004MR	N/A
SC/APC	2900-50-0011MR	2900-52-0002MR	N/A
2.5 mm Universal	N/A	2900-52-0005MR	2900-50-0007MR
1.25 mm Universal	N/A	2900-52-0006MR	2900-50-0010MR

FlexScan® FS200 Single-mode OTDR

Test Management and Reporting Software

DESCRIPTION	AFL NO.
FlexReports Advanced, one seat license on USB	RPTS-AD-USB-1
FlexReports Advanced, one seat, Upgrade from TRM® 3 Advanced on USB. Users must have TRM-3 Advanced license	RPTS-UP-TRM3-1
FlexReports Basic, available for download on AFL Software Resources website	FlexReports Basic
FlexApp data transfer mobile App, available on Google Play and Apple App Store	FlexApp

Recommended Products



FOCIS Flex & FOCIS Lightning2 (Multi-Fiber) Connector Inspection

- Self-contained, tether-free, hand-held inspection solution
- Auto-focus and auto-centering for fast, easy inspection
- IEC, IPC and user-defined pass/fail analysis
- FOCIS Lightning2: extremely fast multi-fiber auto-analysis for datacom and telecom inspection applications



OFI-BIPMe Optical Fiber Identifier

- Works on all fiber types including BIF
- Trigger lock, positive stop for optimum detection
- Integrated optical power meter

Qualifications

CATEGORY	REGULATION/STANDARD	QUALIFICATION
CE Marking	EU	Compliant to relevant EU Directives on health, safety, and environmental protection, and certified with CE marking
Safety/EMC/EMI	IEC	Compliant to IEC 61010-1 for safety requirements for electrical equipment
	EN	Compliant to EN 61010-1 for safety requirements for electrical equipment
	IEC	Compliant to IEC 61326-1 for EMC requirements for electrical equipment
	EN	Compliant to EN 61326-1 for EMC requirements for electrical equipment
	EN	Compliant to EN 55011 for EMC requirements for industrial, scientific and medical equipment
	Telcordia	Compliant to GR-196-CORE 4.5.1 for requirements on electromagnetic interference
	FCC	Bluetooth/Wi-Fi compliant to FCC 47 CFR Part 15C, Part 15.247 subpart C, and FCC Rule Part 1.1.307 (b)(3)(i)(a) SAR
	FDA	Compliant to code of federal regulations FDA 21 CFR 1040.10 and 1040.11 on laser products
RoHS	IEC	Compliant to IEC 60825-1 for safety of laser products
	EU	Compliant to EU regulations Directive 2011/65/EU (RoHS 2) and Directive 2015/863 (RoHS 3)
Test Method	TIA	Compliant to TIA-568.3-D for test and measurement requirements for premises optical fiber cabling and components
	IEC	Compliant to IEC 11801 for test and measurement requirements for optical fiber cabling for use within premises
	AS/NZS	Compliant to AS/NZS 3080 for test and measurement requirements for optical fiber cabling for use within premises
	TIA	Compliant to TIA-526-7 for test procedures for installed optical fiber cable plant
	TIA	Compliant to TIA-526-14 for test procedures for installed optical fiber cable plant
	IEC	Compliant to IEC 14763-3 for systems and methods for the inspection and testing of installed optical fiber cabling
	AS/NZS	Compliant to AS/NZS 14763.3 for systems and methods for the inspection and testing of installed optical fiber cabling
	IEC	Compliant to IEC 61280-4-1 for test procedures for installed optical fiber cable plant
Generic Requirement	IEC	Compliant to IEC 61280-4-2 for test procedures for installed optical fiber cable plant
	Telcordia	Compliant to GR-196-CORE for generic requirements for OTDR-type equipment
	Telcordia	Compliant to SR-4731 Issue 2 for OTDR data format
	IEC	Compliant to IEC 61746-1 for requirements on calibration of OTDR

Contact Sales@AFLglobal.com to schedule a demonstration or learn how to buy.

Visit www.AFLglobal.com/Test to learn more about FlexScan FS200 OTDR.

International Sales and Service Contact Information available at www.AFLglobal.com/Test/Contacts

FlexScan® TS100 FTTH PON Troubleshooter

One-Touch Troubleshooting

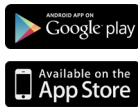

Features

- Locate faults in <3 seconds with the press of a button
- Displays link length, loss, ORL, and pass/fail results
- Single-ended test reduces time and cost
- Rugged, lightweight, hand-held for field use
- Available with field-replaceable connector

Applications

- Troubleshoot PONs or Point-to-Point networks from one end
- Diagnose faults exceeding industry or user pass/fail limits
- Verify loss of PON splitters up to 1:64 split ratio
- Verify GPON, video and XG/XGS-PON or 10GEPON power levels
- Verify insertion loss, TX output or RX input power levels
- Pinpoint location of macro-bends or breaks

AFL's FlexScan TS100 Optical Troubleshooter is an easy-to-use, all-in-one tool for detecting, identifying, locating, and resolving single-mode optical network issues. The TS100 has auto-configured settings to quickly measure received power, link length, loss, and ORL with the push of a button. The results are displayed using color-coded LinkMap® icons for easy analysis. The FlexScan TS100 automates testing, shortens test time, interprets results, and recommends corrective actions, improving efficiency of frontline technicians and reducing costs.

Diagnose your network in seconds: Just press Start and the TS100 immediately measures and displays received power levels when connected to a live GPON and/or 10GPON network. Within seconds, link length, loss, and ORL are displayed, along with faults exceeding industry or user-set pass/fail limits. The TS100 even recommends corrective actions based on test results making it easier for technicians to find and fix network problems.

Requires little, if any, training: Designed primarily for field technicians activating and maintaining broadband access networks, the TS100 requires minimal training and no OTDR experience. SmartAuto® auto-configures test settings and presents network test results in easy-to-understand, color-coded icons indicating passing or failing connections, splices, and splitters.

All-in-one test capability: The FlexScan TS100 includes an integrated VFL, power meter, and light source. It can be easily paired to AFL's award-winning FOCIS family of inspection scopes, ensuring technicians have everything they need to locate and quickly resolve optical network issues. The source and power meter generate and detect fiber-identifying tones and support Wave ID insertion loss testing featuring automatic wavelength identification and synchronization.

Designed for field use: FlexScan TS100 is small (3.5 x 6 x 1.75 in (86 x 160 x 43 mm)) and weighs less than a pound (0.4 kg). It has a large, bright indoor/outdoor touchscreen, and rechargeable battery that lasts >12 hours for all-day operation.

Multiple storing and reporting options: Results can be stored internally, saved to a USB, or wirelessly uploaded via the free FlexApp for real-time reporting using the included FlexReports Test Results Manager software.

Convenient cost-saving kits: Bundle the FlexScan TS100 with your choice of launch cable and FOCIS Flex connector inspection probe with adapter tips for significant cost-savings!

Field-replaceable connector: With AFL's optional field-replaceable connector, avoid expensive service repairs to replace connectors damaged due to poor cleaning practices and/or normal wear-and-tear.

FlexScan® TS100 FTTH PON Troubleshooter

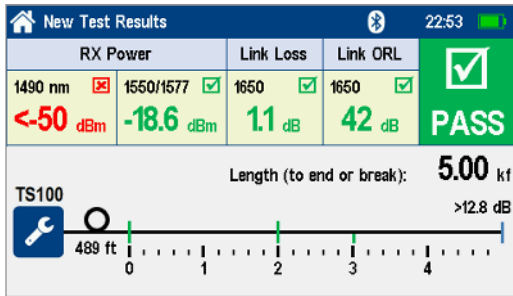

Verify RX Power, Link Length, Loss, and ORL in Seconds

Link length, loss, and ORL are critical parameters to check when verifying optical networks. Within seconds of pressing Start, FlexScan TS100 measures and reports distance, loss, and ORL to the end of a Point-to-Point network or to the first splitter in an FTTH PON. Additionally, for an in-service PON, TS100 automatically detects and measures downstream power levels.

Measurements of received power, link length, loss, and ORL may be compared to pass/fail limits to immediately identify any issues. Technicians can simply touch the failed measurement value to get information on why the measurement failed and what to do about it.

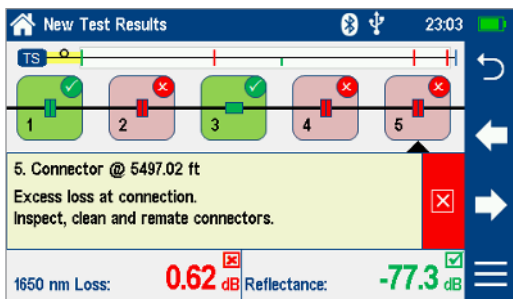

Identifies & Locates Faults - Recommends Corrective Action

TS100 automatically detects network events such as connections, splices, splitters, and macro-bends. It displays these events with LinkMap® color-coded icons that are easy-to-read and enable users to quickly identify faults requiring action. Touching each event icon displays its pass/fail status, location, loss, and reflectance as well as recommended corrective actions. More detail may be obtained by touching the measurement values for failing events.

For PON systems equipped with a 1650 nm downstream monitoring system, the TS100-75 provides a 1625 nm upstream PON troubleshooting tool, which includes a 1650 nm blocking filter.



Connectivity

Results can be stored internally, saved to a USB, or wirelessly uploaded via the free FlexApp to a smart device for real-time reporting using the included FlexReports Test Results Manager PC-based software. This real-time monitoring can help avoid mistakes in the field that will require future truck rolls.

FlexScan TS100 also pairs easily with AFL's award-winning FOCIS® family of connector inspection probes for fast, easy one-button-push inspection of single-fiber and/or multi-fiber connector end-faces. Inspection data can be saved with TS100 results internally or transferred for archiving.

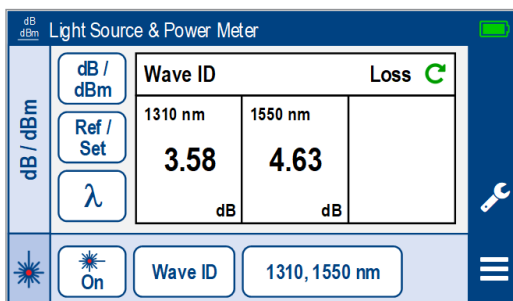

PON Power Meter for GPON, Video, 10GPON

FlexScan TS100 PON Troubleshooters include a broadband power meter plus a downstream PON power meter enabling users to immediately and independently verify 1490 nm GPON plus 1550 nm video or 1577 nm 10GPON (XG/XGS-PON or 10GEAPON).

TS100s also include an optical light source (OLS) and optical power meter (OPM) supporting fiber-identifying tone generation and detection, as well as Wave ID insertion loss measurements. With Wave ID, the OPM auto-synchronizes to a single or multi-wavelength Wave ID optical signal transmitted by another FlexScan or AFL light source. The OPM reports detected wavelengths and measures loss at each wavelength, saving significant test time and eliminating setup errors.

FlexScan® TS100 FTTH PON Troubleshooter

Specifications^a

FlexScan TS100-60/70/75 models support PON and Point-to-Point network troubleshooting at 1625 or 1650 nm and include optical light source (OLS), optical power meter (OPM), visual fault locator (VFL), internal results storage plus Bluetooth and USB interfaces.

MODEL	TS100-60	TS100-70/75
FAULT LOCATOR		
Emitter Type	Laser	
Safety Class ^b	Class I	
Fiber Type	Compatible with all G.65x single-mode fiber	
Wavelengths (nm)	TS100-60/70: 1650 nm; TS100-75: 1625 nm	
Center λ Tolerance ^c	± 20 nm	
Link Loss ^d	≤ 18 dB	≤ 23 dB
Test through Splitter	N/A	Up to 1:64
Test Time	Length, Loss, ORL, faults to end or Splitter: ≤ 3 sec Loss through Splitter: ≤ 40 sec (TS100-70/75 only)	
Index of Refraction	1.3000 to 1.7000	
Distance Resolution	0.1 m	
Distance Uncertainty ^e	± 1.5 m	
Distance Units	m, km, ft, kft, mi (user-selected)	
Loss Resolution	0.01 dB	
Linearity	± 0.05 dB/dB	
Reflectance Resolution	0.1 dB	
Reflectance Accuracy	± 2 dB (-20 to -50 dB)	
Results File Format	Telcordia SR-4731 Issue 2 compatible .SOR	
Results Storage	4 GB internal memory (>5000 traces typical); External USB memory stick	
Data Transfer to PC	USB cable or Bluetooth® (option)	
Test Modes	Flexpress® Fault Locate, OLS/OPM, Inspection	
Live Fiber Protection	No TS100 damage with input power $\leq +15$ dBm for wavelength(s) in range 1260 to 1675 nm	
Live Fiber Detection	Reports live fiber with input signal ≥ -35 dBm for wavelength(s) in range 1260 to 1675 nm	
PON Filter Isolation	>50 dB for 1260 nm \leq wavelength ≤ 1600 nm TS100-75: >30 dB blocking @ 1650 ± 10 nm	
Live PON TS100 Test	1625 or 1650 nm filtered detector	
SPLITTER DETECTION AND LOSS MEASUREMENT (TS100-70 only)		
Splitter Type	Up to 1:64 split ratio	
Fiber length before splitter (with minimum 150 m launch cable)	0 to 5 km	
Maximum fiber loss before splitter	2.5 dB	
Minimum fiber length after splitter (with reflective end)	1:2 splitter	25 m
	1:4 splitter	35 m
	1:8 splitter	50 m
	1:16 splitter	200 m
	1:32 splitter	300 m
	1:64 splitter	500 m

Notes:

- a. All specifications valid at 25 °C unless otherwise specified.
- b. FDA 21 CFR 1040.10 & 1040.11, IEC 60825-1: 2014.
- c. Using 10 ns pulse width.
- d. Maximum link loss for which loss and distance to end or splitter can be reliably detected and measured.
- e. For a 5 km link with insertion loss ≤ 4 dB and reflectance ≥ -45 dB. Excludes uncertainty due to index of refraction.
- f. Max temperature while charging is +45 °C.
- g. Applies when operating from battery with charge level $>20\%$, or from AC when fully charged.

MODEL	TS100-60/70/75
VISUAL FAULT LOCATOR	
Emitter Type	Visible red laser, 650 ± 25 nm
Output Power	1.5 mW (+2 dBm ± 0.5 dB) into single-mode fiber
Safety Class ^b	Class 3A / Class 3R
Modes	CW and 1 Hz flashing
OPTICAL LASER SOURCE (OLS)	
Emitter Type	Laser
Safety Class ^b	Class I
Fiber Type	Compatible with all G.65x single-mode fiber
Wavelengths (nm)	TS100-60/70: 1650 nm; TS100-75: 1625 nm
Center λ Tolerance (CW)	± 20 nm
Spectral Width (FWHM)	≤ 5 nm
Internal Modulation	270, 330, 1000, 2000 Hz, CW, Wave ID
Wave ID	Compatible with AFL OLS/OPM
Output Power Stability ^g	$\leq \pm 0.5$ dB
Output Power	+3 dBm ± 1.5 dB
OPTICAL POWER METER (OPM)	
Calibrated Wavelengths	1270, 1310, 1490, 1550, 1577 nm
Detector Type	Filtered InGaAs (x2)
Measurement Range	+10 to -50 dBm
Linearity	1310/1490 nm: ± 0.1 dB (+5 to -40 dBm); 1550/1577 nm: ± 0.1 dB (+10 to -40 dBm); All: ± 0.25 dB (-40 to -50 dBm)
Tone Detect Range	+3 to -35 dBm; auto-detects 270, 330, 1k, 2k Hz
Wave ID Detect Range	+3 to -35 dBm; auto-detects 1310/1550 Wave ID
Accuracy	± 0.5 dB at -10 dBm
Resolution	0.01 dB
Measurement Units	dB, dBm or Watts (nW, μ W, mW)
GENERAL	
Size (in boot)	86 x 160 x 43 mm
Weight	0.4 kg
Operational Temperature ^f	-10 °C to +50 °C, 0 to 95% RH (non-condensing)
Storage Temperature	-40 °C to +60 °C, 0 to 95% RH (non-condensing)
Power	Rechargeable Li-Pol or AC adapter
Battery Life	>12 hours, Telcordia test conditions
Display	4.3 in color touchscreen LCD, 480x272, backlit
USB Ports	1 host, 1 micro-USB function
Bluetooth (optional)	Compatible with Windows PC, Android, iOS

FlexScan® TS100 FTTH PON Troubleshooter

FlexScan TS100 Kit Configurations

All kits include selected FlexScan TS100 with AC charger, battery, carry strap, SC/2.5 mm connector adapters, FlexReports, USB cable, and soft carry case. PLUS kits add a 150 m fiber ring, One-Click cleaner, and upgrade to FlexReports Advanced software. PRO kits add a FOCIS® Flex auto-focusing connector inspection probe with IEC pass/fail analysis and two adapter tips. TS100s are manufactured with APC connectors.

Ordering Information

TS100-[MOD]-[KIT]-[Pn]-[Wn]-[LNG]-[AC]-[FR]-[TIP] where:

[MOD]	TS100 Configuration
60	1650 nm filtered Live PON Troubleshooter; Test to Splitter
70	1650 nm filtered Live PON Troubleshooter; Test through Splitter
75	1625 nm filtered Live PON Troubleshooter with 1650 nm blocking filter; Test through Splitter

[KIT]	TS100 Kit Configuration/Kit Contents
BAS	Includes: TS100, soft case, FlexReports Basic, USB cable ^a
PLUS	Includes: BAS kit plus 150 m fiber ring, One-Click, FlexReports Advanced
PRO	Includes: PLUS kit plus FOCIS Flex with 2 adapter tips

[Pn]	Power Meter Option
P2	Broadband Power Meter plus dual-wavelength PON Power Meter for GPON / Video / XG/XGS/10GE PON

[Wn]	Bluetooth Wireless Option
W0	Disabled
W1	Installed and enabled

[LNG]	Language
ENG	English
CHS	Chinese Simplified
CHT	Chinese Traditional
CZE	Czech
DEU	German
DNK	Danish
FIN	Finnish
FRA	French

[LNG]	Language
ITA	Italian
JPN	Japanese
KOR	Korean
NOR	Norwegian
POL	Polish
POR	Portuguese
SPA	Spanish
TUR	Turkish

[AC]	Destination Country	AC Plugs
US	USA	2-pin, US
EU	European Union	2-pin, EU
UK	United Kingdom	3-pin, UK
CN	China, Australia	2-pin, SAA

Notes:

- a. Results can be transferred from FlexScan to FlexReports using USB cable, or uploaded via Bluetooth using FlexApp downloaded from 'Google play' or 'App Store'.
- b. For additional FOCIS Flex adapter tips, see FOCIS Flex data sheet or Buyer's Guide.

[FR1]	150 m SMF Fiber Ring
Absent	N/A in Basic kits
USC/USC	FR-SMF-150-USC-USC
USC/UFC	FR-SMF-150-USC-UFC
USC/ULC	FR-SMF-150-USC-ULC
USC/UST	FR-SMF-150-USC-UST
USC/ASC	FR-SMF-150-USC-ASC
USC/AFC	FR-SMF-150-USC-AFC
USC/ALC	FR-SMF-150-USC-ALC
USC/UE2	FR-SMF-150-USC-UE2
ASC/UFC	FR-SMF-150-ASC-UFC
ASC/ULC	FR-SMF-150-ASC-ULC
ASC/UST	FR-SMF-150-ASC-UST
ASC/ASC	FR-SMF-150-ASC-ASC
ASC/AFC	FR-SMF-150-ASC-AFC
ASC/ALC	FR-SMF-150-ASC-ALC
ASC/AE2	FR-SMF-150-ASC-AE2

[TIP] ^b	FOCIS Flex Tips & Cleaning (PRO only)
Blank	Option not available in Basic and PLUS kits
SC	SC-UPC bulkhead tip, 2.5 mm UPC ferrule tip, 2.5 mm One-Click
FC	FC-UPC bulkhead tip, 2.5 mm UPC ferrule tip, 2.5 mm One-Click
LC	LC-UPC bulkhead tip, 1.25 mm UPC ferrule tip, 1.25 mm One-Click
ASC	SC-APC bulkhead tip, 2.5 mm APC ferrule tip, 2.5 mm One-Click
AFC	FC-APC bulkhead tip, 2.5 mm APC ferrule tip, 2.5 mm One-Click
ALC	LC-APC bulkhead tip, 1.25 mm APC ferrule tip, 1.25 mm One-Click

FlexScan® TS100 FTTH PON Troubleshooter

Ordering Information

Accessories

DESCRIPTION	AFL NO.
FlexScan wrist strap	1400-05-0230PZ
FlexScan neck strap, 36"	1400-05-0231PZ
AC charger 100-240 VAC to 5 VDC	4050-00-0931PR
Soft carry case for TS100 kits with FOCIS Flex and Fiber Ring	1400-01-0111PZ
Soft carry case for TS100 kits with FOCIS Flex, OFI-BIPMe and Fiber Ring	1400-01-0128PZ
Hard carry case for TS100 kits with FOCIS Flex, OFI-BIPMe and Fiber Ring	1400-01-0134PZ
Vehicle charger, 12VDC to 5VDC @2A	4050-00-0033MR
Cable, USB-micro B, 5 pin, 6'	6000-00-0031MR
5V USB charging cable (1.5 m), type A to barrel (0.9 X 3.2 X 9 mm)	6000-00-0034PR
One-Clicks, fluid, wipes, etc. See www.AFLglobal.com	Cleaning Supplies

Field-Replaceable OTDR Connector (Optical Port Ferrule Saver)

Protect your OTDR ports from damage due to mating with dirty or damaged launch cables or patch cords or normal wear-and-tear. Equip your FlexScan TS100 with a field-replaceable connector, which installs in seconds and accepts AFL's tool-free interchangeable SC, LC, FC and ST connector adapters.

Replace damaged connectors in the field: When normal wear-and-tear or poor cleaning practices damage the port saver's end-face, replace it in seconds without having to return the OTDR to a service center for an expensive and time-consuming repair.

DESCRIPTION	AFL NO.
Field-replaceable connector; APC female to APC male	2900-58-0001MR
Field-replaceable connector; APC female to UPC male	2900-58-0002MR
Field-replaceable connector; UPC female to APC male	2900-58-0003MR
Field-replaceable connector; UPC female to UPC male	2900-58-0004MR

Connector Adapters

CONNECTOR ADAPTER	AFL NO.		
	OTDR/OLS PORT	OPM PORT	VFL PORT
FC	2900-50-0002MR	2900-52-0001MR	N/A
SC	2900-50-0003MR	2900-52-0002MR	N/A
ST	2900-50-0004MR	2900-52-0003MR	N/A
LC	2900-50-0006MR	2900-52-0004MR	N/A
SC/APC	2900-50-0011MR	N/A	N/A
2.5 mm Universal	N/A	2900-52-0005MR	2900-50-0007MR
1.25 mm Universal	N/A	2900-52-0006MR	2900-50-0010MR

FlexScan® TS100 FTTH PON Troubleshooter

Test Management and Reporting Software

DESCRIPTION	AFL NO.
FlexReports Advanced, one seat license on USB	RPTS-AD-USB-1
FlexReports Advanced, one seat, Upgrade from TRM® 3 Advanced on USB. Users must have TRM-3 Advanced license	RPTS-UP-TRM3-1
FlexReports Basic, available for download on AFL Software Resources website	FlexReports Basic
FlexApp data transfer mobile App, available on Google Play and Apple App Store	FlexApp

Recommended Products



FOCIS Flex and FOCIS Lightning (Multi-Fiber) Connector Inspection

- Self-contained, tether-free, hand-held inspection solution
- Auto-focus and auto-centering for fast, easy inspection
- IEC, IPC and user-defined pass/fail analysis
- FOCIS Lightning: extremely fast multi-fiber auto-analysis for datacom and telecom inspection applications



OFI-BIPMe Optical Fiber Identifier

- World class signal sensitivity
- Trigger lock, positive stop for optimum detection
- Integrated optical power meter option

Qualifications

CATEGORY	REGULATION/STANDARD	QUALIFICATION
CE Marking	EU	Compliant to relevant EU Directives on health, safety, and environmental protection, and certified with CE marking
Safety/EMC/EMI	IEC	Compliant to IEC 61010-1 for safety requirements for electrical equipment
	EN	Compliant to EN 61010-1 for safety requirements for electrical equipment
	IEC	Compliant to IEC 61326-1 for EMC requirements for electrical equipment
	EN	Compliant to EN 61326-1 for EMC requirements for electrical equipment
	EN	Compliant to EN 55011 for EMC requirements for industrial, scientific and medical equipment
	Telcordia	Compliant to GR-196-CORE 4.5.1 for requirements on electromagnetic interference
	FCC	Compliant to code of federal regulations FCC 47 CFR 15 on unlicensed transmissions
	FDA	Compliant to code of federal regulations FDA 21 CFR 1040.10 and 1040.11 on laser products
RoHS	IEC	Compliant to IEC 60825-1 for safety of laser products
	EU	Compliant to EU regulations Directive 2011/65/EU (RoHS 2) and Directive 2015/863 (RoHS 3)
Test Method	TIA	Compliant to TIA-568.3-D for test and measurement requirements for premises optical fiber cabling and components
	IEC	Compliant to IEC 11801 for test and measurement requirements for optical fiber cabling for use within premises
	AS/NZS	Compliant to AS/NZS 3080 for test and measurement requirements for optical fiber cabling for use within premises
	TIA	Compliant to TIA-526-7 for test procedures for installed optical fiber cable plant
	TIA	Compliant to TIA-526-14 for test procedures for installed optical fiber cable plant
	IEC	Compliant to IEC 14763-3 for systems and methods for the inspection and testing of installed optical fiber cabling
	AS/NZS	Compliant to AS/NZS 14763.3 for systems and methods for the inspection and testing of installed optical fiber cabling
	IEC	Compliant to IEC 61280-4-1 for test procedures for installed optical fiber cable plant
Generic Requirement	IEC	Compliant to IEC 61280-4-2 for test procedures for installed optical fiber cable plant
	Telcordia	Compliant to GR-196-CORE for generic requirements for OTDR-type equipment
	Telcordia	Compliant to SR-4731 Issue 2 for OTDR data format
	IEC	Compliant to IEC 61746-1 for requirements on calibration of OTDR

Contact Sales@AFLglobal.com to schedule a demonstration or learn how to buy.

Visit www.AFLglobal.com/Test to learn more about FlexScan TS100 Troubleshooters.

International Sales and Service Contact Information available at www.AFLglobal.com/Test/Contacts

Optical Port Saver – Field-replaceable OTDR Connector



Features

- Prevents damage to factory-installed OTDR ferrules
- Allows damaged connectors to be replaced in the field
- Supports APC and UPC ferrules and connectors
- Available for single-mode and multimode OTDR ports

Applications

- Protect OTDR ferrule from damage due to repeated mating
- Avoid costly repairs due to damaged connectors
- Avoid downtime to return OTDR for connector replacement
- Convert APC to UPC and vice versa

Protect your OTDR ports from damage due to mating with dirty or damaged launch cables, patch cords, or normal wear-and-tear. Equip your FlexScan FS200/ FS300 OTDRs or FlexScan TS100 Troubleshooter with a field-replaceable connector, which installs in seconds and accepts AFL's tool-free interchangeable SC, LC, FC, and ST connector adapters.

Replace damaged connectors in the field: When normal wear-and-tear or poor cleaning practices damage the Port Saver's end-face, replace it in seconds without having to return the OTDR to a service center for an expensive and time-consuming repair.

Easy to install and cost-effective: The Port Saver helps you avoid factory replacement of damaged ferrules caused by dirt and debris. Traditional repair time for factory OTDR ferrules can be over 1 week. With the Port Saver, you can simply swap out the damaged Port Saver in the field with a new one saving time and costly shipping charges to the factory. Its easy, quick, and you will be back to testing in about 2 minutes!

Application and Installation

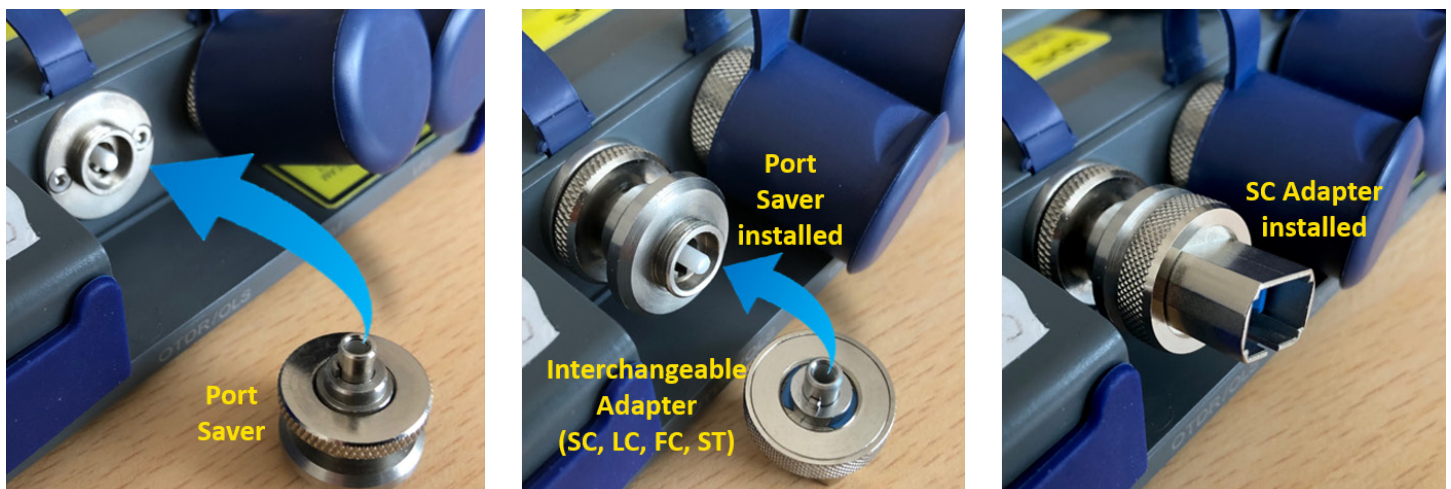

Optical Port Saver – Field-replaceable OTDR Connector

Specifications^a

Optical	
Insertion Loss	≤ 0.75 dB
Reflectance	APC-to-APC: ≤ -55 dB; all others: ≤ -45 dB
Size	Raises height of connector adapter by 16 mm (0.6 in)
Connector compatibility	Accepts FlexScan [®] 2900-50 series SC, LC, FC, ST connector adapters

Notes:

a. All specifications valid at 25°C unless otherwise specified.

Ordering Information

DESCRIPTION	AFL NO.
FlexScan-facing APC female to APC male field-replaceable Port Saver SMF	2900-58-0001MR
FlexScan-facing APC female to UPC male field-replaceable Port Saver SMF	2900-58-0002MR
FlexScan-facing UPC female to APC male field-replaceable Port Saver SMF	2900-58-0003MR
FlexScan-facing UPC female to UPC male field-replaceable Port Saver SMF	2900-58-0004MR
FlexScan-facing UPC female to UPC male field-replaceable Port Saver, 50 μm MMF	2900-58-0014MR

Recommended Products



FlexScan[®] FS300 (quad) and FS200 (single-mode) OTDRs

- SmartAuto[®] 1-button automated testing for fast results
- LinkMap[®] color-coded icons for easy troubleshooting
- FleXpress[®] mode (FS200) completes OTDR test in <5 seconds!
- Integrated Source, Power Meter and VFL



FlexScan[®] TS100 FTTH PON Troubleshooter

- Locate faults in <3 seconds with the press of a button
- Displays link length, loss, ORL, and pass/fail results
- Single-ended test reduces time and cost
- Rugged, lightweight, hand-held for field use

Contact Sales@AFLglobal.com to schedule a demonstration or learn how to buy.

Visit www.AFLglobal.com/Test to learn more about Field-Replaceable OTDR Connectors.

International Sales and Service Contact Information available at www.AFLglobal.com/Test/Contacts

OTDR Fiber Rings



Features

- Compact, rugged, lightweight
- 150, 500, and 1000 m lengths standard
- Available with a variety of connector styles
- Compact! Fits easily in OTDR cases or kits

Applications

- Use to test link loss with an OTDR
- For use as OTDR launch cable
- For use as OTDR receive cable
- Measure insertion loss and reflectance of near- and far-end connections

Fiber Rings are often a necessity when testing with an OTDR or Optical Troubleshooter. A launch cable, which connects the OTDR or Optical Troubleshooter to the link under test, reveals the insertion loss and reflectance of the near-end connection. A receive cable, which connects to the far-end of the link, reveals the insertion loss and reflectance of the far-end connection. Launch and receive test cables can range from 150 m to 1 km (or longer) in length. Because very long test cables are impractical to transport and use, AFL offers coiled lengths of 50 μm multimode, 62.5 μm multimode, or single-mode fiber packaged in compact rings.

Fiber Rings of 150 m of fiber are ideal for premises fiber network test applications. Fiber Rings of 500 m and 1 km of single-mode fiber are designed for broadband, long haul fiber network test applications.

OTDR Fiber Rings

Fiber Rings Part Number Order Entry

Single Fiber (SM or MM) Fiber Rings

AFL NO. = FR-FFF-LLLL-CC1-CC2, where:

FR = Fiber Ring (single fiber)

FFF = Fiber Type

SMF= Single-mode (G.652)

BIF = Bend Insensitive (G.657)

OM1 = 62.5 μm multimode

OM2 = 50 μm multimode

OM3 = 50 μm laser optimized

OM4 = 50 μm laser optimized

LLLL = Fiber Length (meters)

150 = 150 m (492 ft)

500 = 500 m (1640 ft)

1000 = 1000 m (3280 ft)

CC1 = Connector Configuration OTDR end (see below)

CC2 = Connector Configuration Network end (see below)

MPO-terminated Multi-Fiber (SM or MM) Fiber Rings

AFL NO. = FRM1-FF-LLLL-P-MC1-MC2, where:

FRM1 = MPO-terminated 12-fiber fiber ring

FF = Fiber Type

S2 = Standard single-mode (G.652)

M4 = OM4 50 μm laser optimized

LLLL = Fiber Length (meters)

61 = 61 m (200 ft)

P = Polarity

A = Type A polarity (straight through, fiber 1 to fiber 1)

B = Type B polarity (fiber 1 to fiber 12)

MC1, MC2 = MPO Connector (OTDR end and Network end, respectively)

AF = APC, female (unpinned)

AM = APC, male (pinned)

UF = UPC, female (unpinned)

UM = UPC, male (pinned)

Supported Single Fiber Single-mode Fiber Ring Configurations

CONNECTOR TYPE		STANDARD SMF FIBER RINGS		SPECIAL ORDER SMF FIBER RINGS ^a	
ID	DESCRIPTION	CC1	CC2	CC1	CC2
USC	SC/UPC	◆	◆		
ASC	SC/APC	◆	◆		
ULC	LC/UPC		◆	◆	◆
ALC	LC/APC		◆	◆	◆
UFC	FC/UPC		◆	◆	◆
AFC	FC/APC		◆	◆	◆
UST	ST/UPC		◆	◆	◆
UE2	E2000/UPC		Special Order ^a		◆
AE2	E2000/APC		Special Order ^a		◆
OTA	OptiTap APC		Special Order ^a		

Supported Single Fiber Multimode Fiber Ring Configurations

CONNECTOR TYPE		STANDARD SMF FIBER RINGS		SPECIAL ORDER SMF FIBER RINGS ^a	
ID	DESCRIPTION	CC1	CC2	CC1	CC2
USC	SC/UPC	◆	◆		
ULC	LC/UPC		◆	◆	◆
UFC	FC/UPC		◆	◆	◆
UST	ST/UPC		◆	◆	◆
UE2	E2000/UPC		Special Order ^a		

OTDR Fiber Rings

Ordering Information

Standard SMF Fiber Rings

DESCRIPTION	AFL NO.
Fiber Ring, 150 m, G.652 SMF, CC1-CC2	FR-SMF-150-CC1-CC2
Fiber Ring, 500 m, G.652 SMF, CC1-CC2	FR-SMF-500-CC1-CC2
Fiber Ring, 1000 m, G.652 SMF, CC1-CC2	FR-SMF-1000-CC1-CC2

Special Order SMF Fiber Rings^a

DESCRIPTION	AFL NO.
Fiber Ring, 150 m, G.652 SMF, CC1-CC2	FR-SMF-150-CC1-CC2
Fiber Ring, 500 m, G.652 SMF, CC1-CC2	FR-SMF-500-CC1-CC2
Fiber Ring, 1000 m, G.652 SMF, CC1-CC2	FR-SMF-1000-CC1-CC2
Fiber Ring, 150 m, G.657.A2 BIF, CC1-CC2	FR-BIF-150-CC1-CC2
Fiber Ring, 500 m, G.657.A2 BIF, CC1-CC2	FR-BIF-500-CC1-CC2
Fiber Ring, 1000 m, G.657.A2 BIF, CC1-CC2	FR-BIF-1000-CC1-CC2

Standard OM1, OM2, OM3, OM4 Multimode Fiber Rings

DESCRIPTION	AFL NO.
Fiber Ring, 150 m, OM1 (62.5 mm) MMF, CC1-CC2	FR-OM1-150-CC1-CC2
Fiber Ring, 150 m, OM2 (50 mm) MMF, CC1-CC2	FR-OM2-150-CC1-CC2
Fiber Ring, 150 m, OM3 (50 mm laser-optimized) MMF, CC1-CC2	FR-OM3-150-CC1-CC2
Fiber Ring, 150 m, OM4 (50 mm laser-optimized) MMF, CC1-CC2	FR-OM4-150-CC1-CC2

Special Order OM1, OM2, OM3, OM4 Multimode Fiber Rings^a

DESCRIPTION	AFL NO.
Fiber Ring, 150 m, OM1 (62.5 mm) MMF, CC1-CC2	FR-OM1-150-CC1-CC2
Fiber Ring, 150 m, OM2 (50 mm) MMF, CC1-CC2	FR-OM2-150-CC1-CC2
Fiber Ring, 150 m, OM3 (50 mm laser-optimized) MMF, CC1-CC2	FR-OM3-150-CC1-CC2
Fiber Ring, 150 m, OM4 (50 mm laser-optimized) MMF, CC1-CC2	FR-OM4-150-CC1-CC2

Standard MPO-terminated Multi-fiber Single-mode and Multimode Fiber Rings^b

DESCRIPTION	AFL NO.
MPO Fiber Ring, 61 m (200 ft), G.652 SMF, Type A, APC unpinned to APC unpinned	FRM1-S2-61-A-AF-AF
MPO Fiber Ring, 61 m (200 ft), G.652 SMF, Type A, APC unpinned to APC pinned	FRM1-S2-61-A-AF-AM
MPO Fiber Ring, 61 m (200 ft), OM4 MMF, Type A, UPC unpinned to UPC unpinned	FRM1-M4-61-A-UF-UF
MPO Fiber Ring, 61 m (200 ft), OM4 MMF, Type A, UPC unpinned to UPC pinned	FRM1-M4-61-A-UF-UM

Notes:

- a. Contact AFL for special order fiber rings. Not all combinations of lengths and connectors are supported.
- b. Contact AFL for other special order configurations of MPO-terminated multi-fiber single-mode or multimode fiber rings.

OTDR Fiber Rings

How to Generate a Baseline Trace Using Fiber Rings

- Use the Fiber Ring as a launch cable. Connect the Fiber Ring between your OTDR and the fiber link under test. This will allow you to measure the loss of the near-end connection.
- Use the Fiber Ring as a receive cable. Connect the Fiber Ring to the far-end connector of your fiber link under test. This will allow you to measure the loss of the far-end connection.
- By using Fiber Rings as both launch and receive cables, as shown in the diagram below, you can measure total insertion loss of the fiber link under test under test.

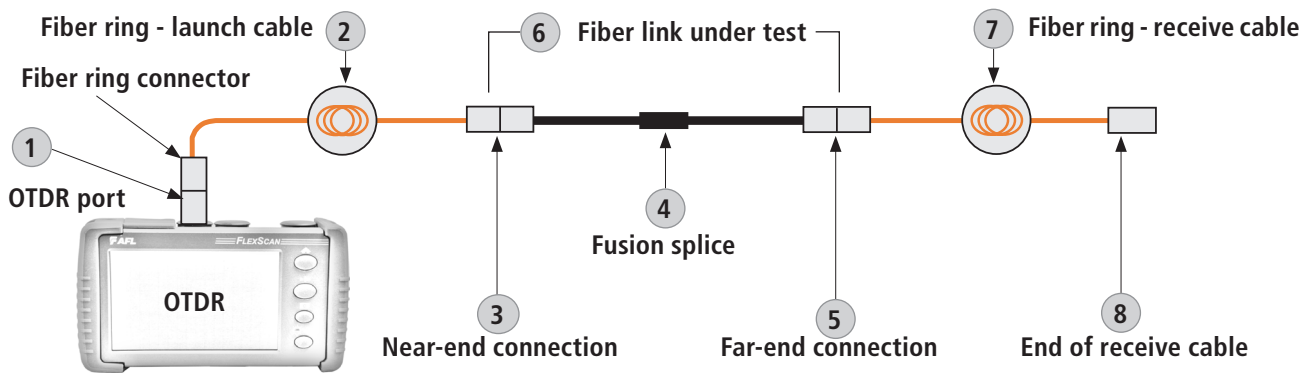

Example OTDR Test Configuration with Launch and Receive Cables

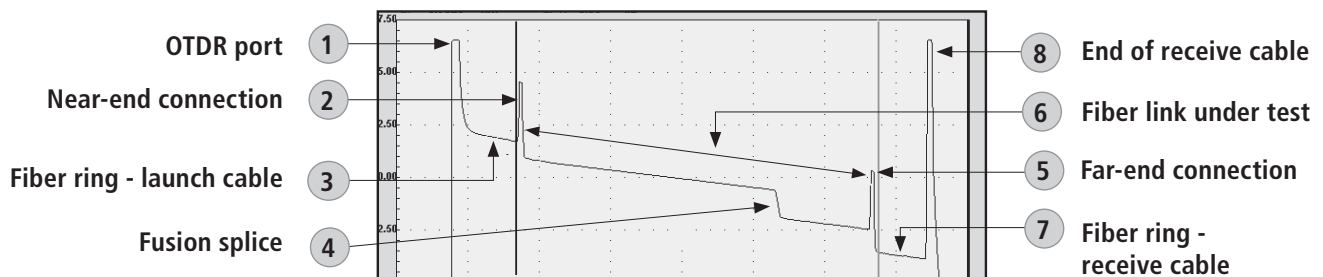

OTDR Trace Made using Launch and Receive Cables

Recommended Products



FlexScan® FS300 (quad) and FS200 (single-mode) OTDRs

- SmartAuto® 1-button automated testing for fast results
- LinkMap® color-coded icons for easy troubleshooting
- FleXpress® mode (FS200) completes OTDR test in <5 seconds!
- Integrated Source, Power Meter and VFL



FlexScan® TS100 FTTH PON Troubleshooter

- Locate faults in <3 seconds with the press of a button
- Displays link length, loss, ORL, and pass/fail results
- Single-ended test reduces time and cost
- Rugged, lightweight, hand-held for field use

Contact Sales@AFLglobal.com to schedule a demonstration or learn how to buy.

Visit www.AFLglobal.com/Test to learn more about Fiber Rings.

International Sales and Service Contact Information available at www.AFLglobal.com/Test/Contacts

NS and NSR Series Fiber Optic Network Simulators



NSR-Series Rack-mountable Network Simulators

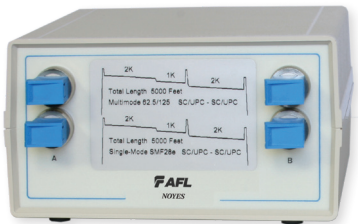

NS-Series NS Bench Top Network Simulators

Features

- User-specified fiber types and lengths
- User-specified events such as splices, connections, macro-bends
- OTDR trace is provided
- A variety of connector styles are available
- Rugged, field-portable

Applications

- Laboratory testing
- Classroom training
- Field troubleshooting
- OTDR calibration

Fiber Optic Network Simulators from AFL are custom built “fiber boxes” intended to duplicate installed fiber optic facilities.

Training schools, laboratory testing or field troubleshooting are just few of the many applications for units. Network simulators may be ordered with customer-specified lengths of multimode or single-mode fiber. Events such as connections, fusion splices, macro-bends and mechanical splices can be added at various points within the fiber to duplicate installed networks. A full range of connector types are available including SC, ST, FC and LC. Angled or non- angled connectors can be specified. Each network simulator includes full documentation for insertion loss, attenuation/km and event location/value.

NS network simulators are housed in rugged field-portable, bench top cases. The NS models accommodates up to 15 km of optical fiber.

NSR network simulators are custom built models housed in either 18 or 23-inch rack-mountable boxes. These network simulators can accommodate up to 100 km of fiber.

Ordering Information

Contact AFL at (800) 321-5298 or (603) 528-6278 for a quote for your custom Network Simulator.

Recommended Products



FlexScan® FS300 (quad) and FS200 (single-mode) OTDRs

- SmartAuto® 1-button automated testing for fast results
- LinkMap® color-coded icons for easy troubleshooting
- FleXpress® mode (FS200) completes OTDR test in <5 seconds!
- Integrated Source, Power Meter and VFL



FlexScan® TS100 FTTH PON Troubleshooter

- Locate faults in <3 seconds with the press of a button
- Displays link length, loss, ORL, and pass/fail results
- Single-ended test reduces time and cost
- Rugged, lightweight, hand-held for field use

Contact Sales@AFLglobal.com to schedule a demonstration or learn how to buy.

Visit www.AFLglobal.com/Test to learn more about network simulators.

International Sales and Service Contact Information available at www.AFLglobal.com/Test/Contacts

FOCIS Flex – Fiber Optic Connector Inspection System

Easy, Fast, Compact, Tether-free

U.S. Patent 9,217,688



Features

- 1-button to auto-focus, center, capture, analyze, and save
- IEC, IPC, and user-defined pass/fail analysis
- Untethered, compact, hand-held inspection
- Use independently or pair with OTDR
- Save 10K results internally or share via WiFi or USB

Applications

- Inspect connectors on patch cords or in bulkhead adapters
- Optical network installation, troubleshooting, and maintenance
- Inspect MPO/MTP multi-fiber connectors
- Assure critical fiber infrastructure performs properly
- Keep fiber connections working at optimal performance levels
- Verify proper connector cleaning practices are being used

FOCIS Flex makes connector inspection simple, fast, and convenient. With the press of a single button, FOCIS Flex auto-focuses, captures and centers the end-face image, applies Pass/Fail rules, displays image and Pass/Fail results, saves results internally and/or wirelessly transfers data to a paired FlexScan OTDR or a smart device. It is fast, small, and easy to use to enable 100% connector inspection.

Independent, untethered operation: With rechargeable battery and integrated display, FOCIS Flex can be used independently without requiring an external OTDR or display unit.

Optional pairing with FlexScan OTDR or smart devices: Captured images and Pass/Fail results can be immediately displayed and easily saved on either paired FlexScan OTDR or a smart device equipped with the AFL's free FOCIS Flex App. This capability enables inspection results to be included in reporting and archiving.

Save results internally or externally: FOCIS Flex internally stores up to 10,000 results using file-naming capabilities similar to those of the FlexScan OTDR. A micro-USB port supports fast upload of internally stored results to PC and ensures your FOCIS Flex software can be updated to the latest features and supported languages.

Wide range of adapter tips: Interchangeable adapter tips support connector inspection for a wide range of both single-fiber and multi-fiber patchcords and bulkhead-mounted connectors having either PC or APC polished end-faces.

Bundled kits for significant savings: FOCIS Flex is available in kits that include a Basic license for Test Result Manager (TRM® 3.0), user-selected adapter tips and cleaning supplies, and a soft carry case.

Easy reporting and archiving: Included Test Result Manager (TRM 3.0) provides data processing and reporting locally via a PC. The FOCIS Flex mobile App is available for free download from Google play or App Store for sharing data with smart devices.

FOCIS Flex – Fiber Optic Connector Inspection System

Easy, Fast, Compact, Tether-free

U.S. Patent 9,217,688

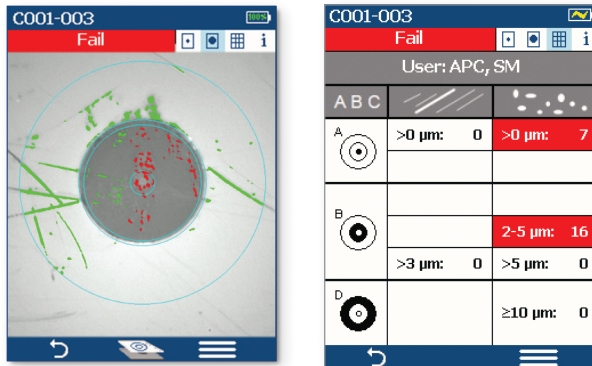

Pass/Fail results in seconds: With the press of a single button, FOCIS Flex auto-focuses, captures and centers the end-face image, applies Pass/Fail rules, displays image and Pass/Fail results. Captured Pass/Fail results are easily viewed in either Image or Table view.

Image view shows end-face image with Pass/Fail region overlay, failing scratches/defects highlighted in red, and passing scratches/defects highlighted in green.

Table view shows analysis rule applied to determine Pass/Fail, analysis Zone IDs (A, B, C, D), scratch analysis results for each zone, and defect analysis results for each zone.

Specifications ^a

OPTICAL PERFORMANCE	
Field of View (viewed on FOCIS Flex)	Live: 710 x 860 μm; Captured, Zoomed Out: 560 x 600 μm; Captured, Partially Zoomed In: 360 x 390 μm; Captured, Fully Zoomed In: 180 x 195 μm
Field of View (Viewed on a PC)	Stored, Zoomed Out: 700 x 525 μm; Stored, Fully Zoomed In: 240 x 180 μm
Manual Detection Capability (minimum)	0.25 μm
Auto Analysis Resolution	<1.0 μm
Captured Image Size (Pixels)	648 x 480 VGA; Images stored internally in three .JPG files, one at each FOV
OPERATING FEATURES	
Focus	Auto-focus and manual focus
Centering	Auto-centering after capture
Pass/Fail Analysis	IEC 61300-3-35 (2015), IPC and user-defined criteria
Image Capture and File Storage Capacity	10,000 files
File Format (Image and Pass/Fail Results)	jpg, gif
Bluetooth Characteristics	SPP to FlexScan and FlexTester OTDRs; IAP to iOS devices
USB Characteristics	USB 1.1 mass storage device
Supported Languages	English, Chinese Simplified, Chinese Traditional, Finnish, French, German, Italian, Japanese, Korean, Polish, Russian, Spanish, Turkish
PHYSICAL AND POWER CHARACTERISTICS	
Display size, type, resolution	2.4", TFT, 240 x 320 with brightness control
Battery Type	NiMH, user replaceable
Battery Operating Time (typical)	8 hours (60 tests in 20 minutes each hour; auto-off enabled)
Recharge Time	<4.5 hours
Power Save Features	Auto-off (disabled, 2, 5, 10 minutes)
AC Charger voltage, frequency, current	100-240 V, 50/60 Hz, 5VDC, 2A
Size	47 x 37 x 183 mm (1.8 x 1.5 x 7.2 in)
Weight	240 g (0.5 lb)
ENVIRONMENTAL CHARACTERISTICS	
Operating Temperature	0 to +50 °C
Storage Temperature	-40 to +70 °C
Relative Humidity	95%, non-condensing
Transit and shock	2G vibration, 30G shock

Notes:

a. All specifications valid at 23°C ±2°C (73.4°F ±3.6°F).

FOCIS Flex – Fiber Optic Connector Inspection System

Easy, Fast, Compact, Tether-free

U.S. Patent 9,217,688

FlexScan OTDR PRO and BIPM Kits with FOCIS Flex

PRO Kits include the following items:

- FlexScan with accessories (AC charger, carry strap, SC/2.5 mm connector adapters, TRM® 3.0 Advanced Test Results Manager, carry case)
- FOCIS Flex Fiber Optic Connector Inspection System with accessories (AC charger, USB cable, soft carry case/holster)
- Two user-selected adapter tips and one user-selected One-Click Cleaner
- 150 m Fiber Ring (launch cable) with user-specified connectors

Complete kits expand on PRO Kits by adding bend insensitive fiber identifier with optional power meter (OFI-BIPM).

See FlexScan data sheet for FlexScan PRO and Complete Kit ordering information.

FOCIS Flex Adapter Tips (Contact AFL for adapter tips for other connector types)

DESCRIPTION	AFL NO.
SC-UPC bulkhead adapter tip	FFLX-01-SC
FC-UPC bulkhead adapter tip	FFLX-01-FC
ST-UPC bulkhead adapter tip	FFLX-01-ST
LC-UPC bulkhead adapter tip	FFLX-01-LC
Universal 2.5 mm, UPC ferrule adapter tip	FFLX-01-U25
Universal 1.25 mm, UPC ferrule adapter tip	FFLX-01-U125
SC-APC bulkhead adapter tip	FFLX-4S-ASC
FC-APC bulkhead adapter tip	FFLX-4S-AFC
LC-APC bulkhead adapter tip	FFLX-4S-ALC
Universal 2.5 mm, APC ferrule adapter tip	FFLX-01-A25
Universal 1.25 mm, APC ferrule adapter tip	FFLX-01-A125
FOCIS Flex adapter extension tube, straight, 46 mm	FFLX-01-EXTS46
FOCIS Flex adapter extension tube, straight, 80 mm:	FFLX-01-EXTS80
E2000 PC/UPC bulkhead adapter tip	FFLX-4S-E2K
E2000 APC bulkhead adapter tip	FFLX-4S-E2KA
Tip for SC/APC (OptiTap®) bulkhead adapter	FFLX-4S-OTA
Tip for OptiTip® APC ferrule and bulkhead adapter	DFS1-01-0013MR
MTP/PC ferrule & bulkhead adapter extended tip kit (base plus MTP/PC front end tip)	DFS1-00-0037MR
MTP/PC and MTP/APC ferrule & bulkhead adapter extended tip kit (base, MTP/PC, MTP/APC front end tips)	DFS1-00-0042MR
MTP/APC ferrule and bulkhead adapter extended tip kit (base plus MTP/APC front end tip)	DFS1-01-0010MR

Ordering Information

DESCRIPTION	AFL NO.
FOCIS Flex Kit, soft carry case/holster, USB cable, AC charger, TRM® 3.0 reporting software, reference guide, no tips	FOCIS-FLX-P4XN
FOCIS Flex Kit, soft carry case/holster, USB cable, AC charger, TRM 3.0 reporting software, reference guide, 2 user-selected UPC adapter tips (ferrule and bulkhead), user-selected One-Click cleaner	FOCIS-FLX-P4XU
FOCIS Flex Kit, soft carry case/holster, USB cable, AC charger, TRM 3.0 reporting software, reference guide, 2 user-selected APC adapter tips (ferrule and bulkhead), user-selected One-Click cleaner	FOCIS-FLX-P4XA
FOCIS Flex Kit, soft carry case/holster, USB cable, AC charger, TRM 3.0 reporting software, reference guide, user-selected UPC adapter tips (ferrule and bulkhead), 2 user-selected APC adapter tips (ferrule and bulkhead), user-selected One-Click cleaner	FOCIS-FLX-P4XUA

FOCIS Flex – Fiber Optic Connector Inspection System

Easy, Fast, Compact, Tether-free

U.S. Patent 9,217,688

Test Management and Reporting Software

DESCRIPTION	AFL NO.
TRM 3.0 with Basic License, USB delivery (included with all FOCIS Flex kits)	TRM3-BASIC
TRM 3.0 upgrade from Basic to Advanced License, USB delivery	TRM3-UPGRADE
TRM 3.0 upgrade from Basic to Advanced License, email delivery	TRM3-UP-EMAIL
FOCIS Flex App (Google play or App Store)	Free Download

Recommended Products



FlexScan® FS300 (quad) and FS200 (single-mode) OTDRs

- SmartAuto® 1-button automated testing for fast results
- LinkMap® color-coded icons for easy troubleshooting
- FleXpress® mode (FS200) completes OTDR test in <5 seconds!
- Integrated Source, Power Meter and VFL



OFI-BIPM Optical Fiber Identifier

- World class signal sensitivity
- Trigger lock, positive stop for optimum detection
- Integrated optical power meter option

Qualifications

CATEGORY	REGULATION/STANDARD	QUALIFICATION
CE Marking	EU	Compliant to relevant EU Directives on health, safety, and environmental protection, and certified with CE marking
Safety /EMC /EMI	IEC	Compliant to IEC 61010-1 for safety requirements for electrical equipment
	EN	Compliant to EN 61010-1 for safety requirements for electrical equipment
	IEC	Compliant to IEC 61326-1 for EMC requirements for electrical equipment
	EN	Compliant to EN 61326-1 for EMC requirements for electrical equipment
	EN	Compliant to EN 55011 for EMC requirements for industrial, scientific and medical equipment
	FCC	Compliant to code of federal regulations FCC 47 CFR 15 on unlicensed transmissions
	FDA	Compliant to code of federal regulations FDA 21 CFR 1040.10 and 1040.11 on laser products
RoHS	IEC	Compliant to IEC 60825-1 for safety of laser products
	EU	Compliant to EU regulations Directive 2011/65/EU (RoHS 2) and Directive 2015/863 (RoHS 3)
Test Method	IEC	Compliant to IEC 61300-3-35 for visual inspection of fiber optic connectors and fiber-stub transceivers
	IPC	Compliant to IPC-8497-1 for cleaning methods and contamination assessment for optical assembly

Contact Sales@AFLglobal.com to schedule a demonstration or learn how to buy.

Visit www.AFLglobal.com/Test to learn more about FOCIS Flex.

International Sales and Service Contact Information available at www.AFLglobal.com/Test/Contacts.

FOCIS Flex No Wireless Fiber Optic Connector Inspection System

Easy, Fast, Compact, Tether-free



Features

- Removes Bluetooth and WiFi features for secure network facility compliance
- 1-button to auto-focus, center, capture, analyze, and save
- IEC, IPC, and user-defined pass/fail analysis
- Untethered, compact, hand-held inspection
- Use independently or pair with OTDR
- Generate inspection reports using TRM® 3.0

Applications

- Inspect connectors on patch cords or in bulkhead adapters
- Optical network installation, troubleshooting, and maintenance
- Inspect MPO/MTP multi-fiber connectors
- Assure critical fiber infrastructure performs properly
- Keep fiber connections working at optimal performance levels
- Verify proper connector cleaning practices are being used

The FOCIS Flex No Wireless (NW) addresses the need of network maintenance contractors operating in secure environments, where devices emitting radio frequency (RF) communication signals are prohibited, such as government and defense facilities and restricted private enterprise network facilities. FOCIS Flex makes connector inspection simple, fast, and convenient. With the press of a single button, FOCIS Flex auto-focuses, captures and centers the end-face image, applies Pass/Fail rules, displays image and Pass/Fail results, saves results internally and/or wirelessly transfers data to a paired FlexScan OTDR or a smart device. It is fast, small, and easy to use to enable 100% connector inspection.

Independent, untethered operation: With rechargeable battery and integrated display, FOCIS Flex can be used independently without requiring an external OTDR or display unit.

Optional pairing with FlexScan OTDR or smart devices: Captured images and Pass/Fail results can be immediately displayed and easily saved on either paired FlexScan OTDR or a smart device equipped with the AFL's free FOCIS Flex App. This capability enables inspection results to be included in reporting and archiving.

Save results internally or externally: FOCIS Flex internally stores up to 10,000 results using file-naming capabilities similar to those of the FlexScan OTDR. A micro-USB port supports fast upload of internally stored results to PC and ensures your FOCIS Flex software can be updated to the latest features and supported languages.

Wide range of adapter tips: Interchangeable adapter tips support connector inspection for a wide range of both single-fiber and multi-fiber patchcords and bulkhead-mounted connectors having either PC or APC polished end-faces.

Bundled kits for significant savings: FOCIS Flex is available in kits that include a Basic license for Test Result Manager (TRM® 3.0), user-selected adapter tips and cleaning supplies, and a soft carry case.

Easy reporting and archiving: Included Test Result Manager (TRM 3.0) provides data processing and reporting locally via a PC.

FOCIS Flex No Wireless Fiber Optic Connector Inspection System

Easy, Fast, Compact, Tether-free

Fiber Inspection

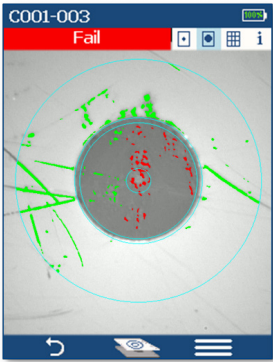

C001-003	
Fail	
User: APC, SM	
A B C	
A	>0 μm: 0 >0 μm: 7
B	2-5 μm: 16
	>3 μm: 0 >5 μm: 0
D	≥10 μm: 0

Pass/Fail results in seconds: With the press of a single button, FOCIS Flex auto-focuses, captures and centers the end-face image, applies Pass/Fail rules, displays image and Pass/Fail results. Captured Pass/Fail results are easily viewed in either Image or Table view.

Image view shows end-face image with Pass/Fail region overlay, failing scratches/defects highlighted in red, and passing scratches/defects highlighted in green.

Table view shows analysis rule applied to determine Pass/Fail, analysis Zone IDs (A, B, C, D), scratch analysis results for each zone, and defect analysis results for each zone.

Specifications ^a

OPTICAL PERFORMANCE	
Field of View (viewed on FOCIS Flex)	Live: 710 x 860 μm; Captured, Zoomed Out: 560 x 600 μm; Captured, Partially Zoomed In: 360 x 390 μm; Captured, Fully Zoomed In: 180 x 195 μm
Field of View (Viewed on a PC)	Stored, Zoomed Out: 700 x 525 μm; Stored, Fully Zoomed In: 240 x 180 μm
Manual Detection Capability (minimum)	0.25 μm
Auto Analysis Resolution	<1.0 μm
Captured Image Size (Pixels)	648 x 480 VGA; Images stored internally in three .JPG files, one at each FOV
OPERATING FEATURES	
Focus	Auto-focus and manual focus
Centering	Auto-centering after capture
Pass/Fail Analysis	IEC 61300-3-35 (2015), IPC and user-defined criteria
Image Capture and File Storage Capacity	10,000 files
File Format (Image and Pass/Fail Results)	jpg, gif
USB Characteristics	USB 1.1 mass storage device
Supported Languages	English, Chinese Simplified, Chinese Traditional, Finnish, French, German, Italian, Japanese, Korean, Polish, Russian, Spanish, Turkish
PHYSICAL AND POWER CHARACTERISTICS	
Display size, type, resolution	2.4", TFT, 240 x 320 with brightness control
Battery Type	NiMH, user replaceable
Battery Operating Time (typical)	8 hours (60 tests in 20 minutes each hour; auto-off enabled)
Recharge Time	<4.5 hours
Power Save Features	Auto-off (disabled, 2, 5, 10 minutes)
AC Charger voltage, frequency, current	100-240 V, 50/60 Hz, 5VDC, 2A
Size	47 x 37 x 183 mm (1.8 x 1.5 x 7.2 in)
Weight	240 g (0.5 lb)
ENVIRONMENTAL CHARACTERISTICS	
Operating Temperature	0 to +50 °C
Storage Temperature	-40 to +70 °C
Relative Humidity	95%, non-condensing
Transit and shock	2G vibration, 30G shock

Notes:

a. All specifications valid at 23°C ±2°C (73.4°F ±3.6°F).

FOCIS Flex No Wireless Fiber Optic Connector Inspection System

Easy, Fast, Compact, Tether-free

FlexScan OTDR PRO and BIPM Kits with FOCIS Flex

PRO Kits include the following items:

- FlexScan with accessories (AC charger, carry strap, SC/2.5 mm connector adapters, TRM® 3.0 Advanced Test Results Manager, carry case)
- FOCIS Flex Fiber Optic Connector Inspection System with accessories (AC charger, USB cable, soft carry case/holster)
- Two user-selected adapter tips and one user-selected One-Click Cleaner
- 150 m Fiber Ring (launch cable) with user-specified connectors

Complete kits expand on PRO Kits by adding bend insensitive fiber identifier with optional power meter (OFI-BIPM).

See FlexScan data sheet for FlexScan PRO and Complete Kit ordering information.

FOCIS Flex Adapter Tips (Contact AFL for adapter tips for other connector types)

DESCRIPTION	AFL NO.
SC-UPC bulkhead adapter tip	FFLX-01-SC
FC-UPC bulkhead adapter tip	FFLX-01-FC
ST-UPC bulkhead adapter tip	FFLX-01-ST
LC-UPC bulkhead adapter tip	FFLX-01-LC
Universal 2.5 mm, UPC ferrule adapter tip	FFLX-01-U25
Universal 1.25 mm, UPC ferrule adapter tip	FFLX-01-U125
SC-APC bulkhead adapter tip	FFLX-4S-ASC
FC-APC bulkhead adapter tip	FFLX-4S-AFC
LC-APC bulkhead adapter tip	FFLX-4S-ALC
Universal 2.5 mm, APC ferrule adapter tip	FFLX-01-A25
Universal 1.25 mm, APC ferrule adapter tip	FFLX-01-A125
FOCIS Flex adapter extension tube, straight, 46 mm	FFLX-01-EXTS46
FOCIS Flex adapter extension tube, straight, 80 mm:	FFLX-01-EXTS80
E2000 PC/UPC bulkhead adapter tip	FFLX-4S-E2K
E2000 APC bulkhead adapter tip	FFLX-4S-E2KA
Tip for SC/APC (OptiTap®) bulkhead adapter	FFLX-4S-OTA
Tip for OptiTap® APC ferrule and bulkhead adapter	DFS1-01-0013MR
MTP/PC ferrule & bulkhead adapter extended tip kit (base plus MTP/PC front end tip)	DFS1-00-0037MR
MTP/PC and MTP/APC ferrule & bulkhead adapter extended tip kit (base, MTP/PC, MTP/APC front end tips)	DFS1-00-0042MR
MTP/APC ferrule and bulkhead adapter extended tip kit (base plus MTP/APC front end tip)	DFS1-01-0010MR

Ordering Information

DESCRIPTION	AFL NO.
FOCIS Flex Kit, soft carry case/holster, USB cable, AC charger, TRM® 3.0 reporting software, reference guide, no tips	FOCIS-FLX-NW-P4XN
FOCIS Flex Kit, soft carry case/holster, USB cable, AC charger, TRM 3.0 reporting software, reference guide, 2 user-selected UPC adapter tips (ferrule and bulkhead), user-selected One-Click cleaner	FOCIS-FLX-NW-P4XU
FOCIS Flex Kit, soft carry case/holster, USB cable, AC charger, TRM 3.0 reporting software, reference guide, 2 user-selected APC adapter tips (ferrule and bulkhead), user-selected One-Click cleaner	FOCIS-FLX-NW-P4XA

FOCIS Flex No Wireless Fiber Optic Connector Inspection System

Easy, Fast, Compact, Tether-free

Test Management and Reporting Software

DESCRIPTION	AFL NO.
TRM 3.0 with Basic License, USB delivery (included with all FOCIS Flex No Wireless. kits)	TRM3-BASIC
TRM 3.0 upgrade from Basic to Advanced License, USB delivery	TRM3-UPGRADE
TRM 3.0 upgrade from Basic to Advanced License, email delivery	TRM3-UP-EMAIL

Recommended Products



FlexScan® FS300 (quad) and FS200 (single-mode) OTRDs

- SmartAuto® 1-button automated testing for fast results
- LinkMap® color-coded icons for easy troubleshooting
- FleXpress® mode (FS200) completes OTDR test in <5 seconds!
- Integrated Source, Power Meter and VFL



OFI-BIPM Optical Fiber Identifier

- World class signal sensitivity
- Trigger lock, positive stop for optimum detection
- Integrated optical power meter option

Qualifications

CATEGORY	REGULATION/STANDARD	QUALIFICATION
CE Marking	EU	Compliant to relevant EU Directives on health, safety, and environmental protection, and certified with CE marking
Safety /EMC /EMI	IEC	Compliant to IEC 61010-1 for safety requirements for electrical equipment
	EN	Compliant to EN 61010-1 for safety requirements for electrical equipment
	IEC	Compliant to IEC 61326-1 for EMC requirements for electrical equipment
	EN	Compliant to EN 61326-1 for EMC requirements for electrical equipment
	EN	Compliant to EN 55011 for EMC requirements for industrial, scientific and medical equipment
	FCC	Compliant to code of federal regulations FCC 47 CFR 15 on unlicensed transmissions
	FDA	Compliant to code of federal regulations FDA 21 CFR 1040.10 and 1040.11 on laser products
RoHS	IEC	Compliant to IEC 60825-1 for safety of laser products
	EU	Compliant to EU regulations Directive 2011/65/EU (RoHS 2) and Directive 2015/863 (RoHS 3)
Test Method	IEC	Compliant to IEC 61300-3-35 for visual inspection of fiber optic connectors and fiber-stub transceivers
	IPC	Compliant to IPC-8497-1 for cleaning methods and contamination assessment for optical assembly

Contact Sales@AFLglobal.com to schedule a demonstration or learn how to buy.

Visit www.AFLglobal.com/Test to learn more about FOCIS Flex No Wireless.

International Sales and Service Contact Information available at www.AFLglobal.com/Test/Contacts.

FOCIS Lightning[®]2 Multi-Fiber Optic Connector Inspection System



Mobile App



PC Software



Features

- Large, simple-to-use touch screen
- Self-contained, tether-free, compact, hand-held inspection solution
- Auto-focus and auto-centering for fast, easy inspection
- Up to 8x zoom for enhanced fiber end-face viewing
- Stores 10k images or easily shares data via USB or Bluetooth connectivity
- IEC, IPC, AT&T, and user-defined auto-analysis
- Wide variety of adapter tips for MPO and single-fiber connector types

Applications

- Inspect multi-fiber and single-fiber connectors and adapters
- Data center fiber network installation, turn-up, and troubleshooting
- Inspect hardened connectors in FTTx network
- Verify proper connector cleaning practices
- Pair with OTDR for comprehensive reporting

FOCIS Lightning2 is a compact self-contained inspection probe that captures and displays the entire MPO end-face image in less than two seconds. One button provides auto-focusing, centering, and Pass/Fail analysis at the connector and individual fiber level. It can be used to inspect MPO-8, -12, -16, -24 and -32 connectors. Results can be easily shared via USB and Bluetooth[®].

Pass/Fail results in seconds: FOCIS Lightning2 was designed to quickly inspect multi-fiber connectors and bulkheads, such as MPO and MTP[®], including multi-row varieties. It can perform industry standard and user-defined end-face cleanliness analysis at a rate of about 1 second per fiber – significantly speeding up inspection time when compared with other technologies.

Internal storage and multiple export options: FOCIS Lightning2 can store 10,000 individual fiber images, analysis, overlays, and zones tables locally and can provide optional Bluetooth wireless links for archiving and reporting. AFL's FlexApp (iOS and Android) provides a comprehensive and user-friendly feature set as well as connectivity with AFL's FlexReporter-Cloud.

Untethered operation: With rechargeable battery and integrated 3.5" TFT color LCD touchscreen, FOCIS Lightning2 can be used independently.

Multi-fiber front-end adapter tips: Multi-fiber front-end adapter tips support single row and multi-row MPO connector inspection for a wide range of patch cords and bulkhead-mounted connectors having either PC/UPC or APC polished end-faces. The probe snout includes a key which in combination with a slot on the adapter tips ensures that adapter tips never loosen during use, under any circumstances.

Easy reporting and archiving: The FlexReporter[™] software suite is a complete platform for report generation and results sharing. This platform includes FlexApp, a mobile App that wirelessly transfers test results from the field to the Cloud. These results can be accessed via FlexReports that provide a variety of easy-to-use options for report generation. FlexReports Basic is included with all AFL OTDRs and enables users to quickly view and analyze results, generate simple single-fiber OTDR and OLTS reports. FlexReports Basic also includes a 60-day Advanced trial that includes full reporting and OTDR Trace Batch Editing.

FOCIS Lightning®2 Multi-Fiber Optic Connector Inspection System

Specifications^a

OPTICAL PORT PARAMETERS	SPECIFICATION
Field of View (FOV; viewed on FOCIS Lightning2)	LFOV ^b Live: 4333 x 6500 µm and 4333 x 5418 µm LFOV ^b Captured: 4333 x 5418 µm Multi Fibers Live: 3200 x 4800 µm and 3200 x 4000 µm Multi Fibers Captured: 3200 x 4000 µm Multi Fibers Captured, Details: 200 x 225 µm Single Fiber Live: 1314 x 2144 µm and 1314 x 1788 µm Single Fiber Captured: 1314 x 1626 µm
Field of View (FOV; viewed on a PC)	LFOV ^b : 4333 x 6500 µm Multi Fibers: 3200 x 4800 µm Single Fiber: 1314 x 2144 µm
Manual Detection Capability (minimum)	0.25 µm
Auto Analysis Resolution	<1.0 µm
Internally Stored Image Size (pixels)	LFOV ^b : 3840 x 2560 JPG file Multi Fibers: 3840 x 2560 JPG file, N x 160 x 160 pixels .GIF files Single Fiber: 3840 x 2560 JPG file, 468 x 468 pixels .GIF file
Bluetooth Image and Overlay	2 x QVGA (320 x 240; image + overlay) to AFL test instruments 2 x VGA (640 x 480; image + overlay) files to Apple iOS and Android devices (IAP / MFi)
Maximum No Damage Live Fiber Power Level	+20 dBm; image cannot be viewed if fiber is live
Focus Methods	Auto-focus and manual focus
Centering	Auto-centering captured single fiber images
Zoom in Live Mode	1x / 2x / 4x / 8x zoom
Image Capture with Pass/Fail Analysis	IEC 61300-3-35 (2015), AT&T TP-76461, IPC-8497-1, user-set criteria
Results Storage (Image and Pass/Fail Results)	Yes
File Format	JPG, GIF
File Storage Capacity	10,000 files
Result Storage Capacity	Multi Fibers: 1000; Single Fiber:1500
OPERATING FEATURES	
Bluetooth Characteristics (Wireless only)	IAP (iPod Accessory Protocol), SPP 0 x 1101, Apple MFi
USB Characteristics	Connector USB-C, Charging, USB 2.0 Mass Storage Device
ENVIRONMENT PARAMETERS	
Storage Temperature	-40 °C to +70 °C
Operating Temperature	0 °C to +50 °C
Relative Humidity	0 to 95% RH
Vibration Limits	2G (transportation)
Transit Drop (without soft case)	300 mm (12 inches, all sides, dust cover installed)
Transit Drop (with soft case)	460 mm (18 inches, all sides, dust cover installed)

Notes:

- All specifications valid at 23°C ±2°C (73.4°F ±3.6°F).
- Large Field of View (LFOV) parameters are provided using LFOV MPO PC and APC adapters.
- Operating conditions: 60 tests in 20 minutes, then auto-off; repeat each hour.
- Trademarks are the property of their respective owners.

FOCIS Lightning[®]2 Multi-Fiber Optic Connector Inspection System

Specifications^a

PHYSICAL AND POWER CHARACTERISTICS	
Display Size, Type, Resolution	3,5" color TFT touch screen with backlit, 320 x 480 with brightness control
Battery Type	Li-Pol, user-replaceable
Operating Time (typical)	8 hours ^c ; 5 hours continuous ^c
Power Save Features	Auto-off (disabled, 2, 5, 10 min)
Low-Battery Warning	Alerts when ≤15 minutes battery operation remains
Size	67 x 32 x 190 mm (2.7 x 1.3 x 7.5 in)
Weight	280 g (0.62 lb)
Safety & Compliance Certifications	UL, CE, FCC

Ordering Information

DESCRIPTION	AFL NO.
FOCIS Lightning2 Kit, soft carry case, USB cable, with no tips or One-Click [®] cleaner	FOCIS-LT2-N
FOCIS Lightning2 Kit, soft carry case, USB cable, (1) UPC ferrule and bulkhead adapter tip, (2) One-Click MPO cleaners	FOCIS-LT2-U
FOCIS Lightning2 Kit, soft carry case, USB cable, (1) APC ferrule and bulkhead adapter tip, (2) One-Click MPO cleaners	FOCIS-LT2-A
FOCIS Lightning2 Kit, soft carry case, USB cable, (1) UPC and (1) APC ferrule and bulkhead adapter tips, (2) One-Click MPO cleaners	FOCIS-LT2-UA
FOCIS Lightning2 Kit, soft carry case, USB cable, (1) UPC and (1) APC ferrule and bulkhead adapter tips, (2) One-Click MPO cleaners, single fiber adapter	FOCIS-LT2-UASF
FOCIS Lightning2 No Wireless Kit, soft carry case, USB cable, with no tips or One-Click cleaner	FOCIS-LT2-NW-N
FOCIS Lightning2 No Wireless Kit, soft carry case, USB cable, (1) UPC ferrule and bulkhead adapter tip, (2) One-Click MPO cleaners	FOCIS-LT2-NW-U
FOCIS Lightning2 No Wireless Kit, soft carry case, USB cable, (1) APC ferrule and bulkhead adapter tip, (2) One-Click MPO cleaners	FOCIS-LT2-NW-A
FOCIS Lightning2 No Wireless Kit, soft carry case, USB cable, (1) UPC and (1) APC ferrule and bulkhead adapter tips, (2) One-Click MPO cleaners	FOCIS-LT2-NW-UA
FOCIS Lightning2 No Wireless Kit, soft carry case, USB cable, (1) UPC and (1) APC ferrule and bulkhead adapter tips, (2) One-Click MPO cleaners, single-fiber adapter	FOCIS-LT2-NW-UASF

FOCIS Lightning Adapter Tips and Accessories

DESCRIPTION	TIP ID	AFL NO.
Adapter tip for MPO-12/24 APC bulkhead (with key)	M12A	FLTNG-01-M12A
Adapter tip for MPO-12/24 UPC bulkhead (with key)	M12U	FLTNG-01-M12U
Adapter tip for MPO-16/32 UPC bulkhead (with key)	M16U	FLTNG-01-M16U
Adapter tip for MPO-12/16/24/32 UPC bulkhead (no key)	MPOU	FLTNG-01-MPOU
Adapter Tip for MPO-12/16/24/32 APC connector (with key)	MAC	FLTNG-01-MAC
Adapter Tip for MPO-12/16/24/32 UPC connector (with key)	MUC	FLTNG-01-MUC
Adapter Tip for OptiTip male (pinned) connector	OPTM	FLTNG-01-OPTM
Adapter Tip for OptiTip female (unpinned) connector	OPTF	FLTNG-01-OPTF
Coupler for most 'FFLX' single fiber connector adapter tips	SFC	FLTNG2-01-SFC
Extended adapter tip for LC-APC bulkhead	ALCM	FLTNG-01-ALCM
Extended adapter tip for LC-UPC bulkhead	ULCM	FLTNG-01-ULCM
MPO extender barrel	MPE	FLTNG-01-MPE
Adapter tip for Large Field of View (LFOV) - UPC	LVU	FLTNG2-01-LVU

Notes:

- a. All specifications valid at 23 °C ±2°C (73.4 °F ±3.6 °F).
- b. Large Field of View (LFOV) parameters are provided using LFOV MPO PC and APC adapters.
- c. Operating conditions: 60 tests in 20 minutes, then auto-off; repeat each hour.
- d. Trademarks are the property of their respective owners.

FOCIS Lightning[®]2 Multi-Fiber Optic Connector Inspection System

Test Management and Reporting Software

FlexReports Basic software is available as free download on AFL Software Resources website. FlexReports Basic includes a 60-day Advanced software trial. Once the evaluation period ends, users must upgrade to FlexReports Advanced software license to continue using FlexReports Advanced features.

DESCRIPTION	AFL NO.
FlexReports Advanced, one seat license on USB	RPTS-AD-USB-1
FlexReports Advanced, one seat, Upgrade from TRM [®] 3 Advanced on USB. Users must have TRM-3 Advanced license	RPTS-UP-TRM3-1
FlexReports Basic, available for download on AFL Software Resources website	FlexReports Basic
FlexApp data transfer mobile App, available on Google Play and Apple App Store	FlexApp

Recommended Products



FlexScan[®] FS300 (quad) and FS200 (single-mode) OTRDRs

- SmartAuto[®] 1-button automated testing for fast results
- LinkMap[®] color-coded icons for easy troubleshooting
- Flexpress[®] mode (FS200) completes OTDR test in <5 seconds!
- Integrated Source, Power Meter and VFL



One-Click[®] Cleaner MPO / MPO-16

- Ideal for Data Centers and high density optical networks
- Designed to work on MTP[®]/MPO multi-fiber connectors
- Cleans connectors on jumpers and in adapters

Qualifications

CATEGORY	REGULATION/STANDARD	QUALIFICATION
CE Marking	EU	Compliant to relevant EU Directives on health, safety, and environmental protection, and certified with CE marking
Safety /EMC /EMI	IEC	Compliant to IEC 61010-1 for safety requirements for electrical equipment
	EN	Compliant to EN 61010-1 for safety requirements for electrical equipment
	IEC	Compliant to IEC 61326-1 for EMC requirements for electrical equipment
	EN	Compliant to EN 61326-1 for EMC requirements for electrical equipment
	EN	Compliant to EN 55011 for EMC requirements for industrial, scientific and medical equipment
	FCC	Compliant to code of federal regulations FCC 47 CFR 15 on unlicensed transmissions
RoHS	EU	Compliant to EU regulations Directive 2011/65/EU (RoHS 2) and Directive 2015/863 (RoHS 3)
Test Method	IEC	Compliant to IEC 61300-3-35 for visual inspection of fiber optic connectors and fiber-stub transceivers
	IPC	Compliant to IPC-8497-1 for cleaning methods and contamination assessment for optical assembly

Contact Sales@AFLglobal.com to schedule a demonstration or learn how to buy.

Visit www.AFLglobal.com/Test to learn more about FOCIS Lightning2.

International Sales and Service Contact Information available at www.AFLglobal.com/Test/Contacts.

Cleaning Kits



FCP1 Kit



FCP2 Kit



FCP3 Kit

Features

- Mix of wet and dry cleaning products for most applications
- MPO/MTP® Option
- Field portable
- Convenient refill options

Applications

- Field cleaning connectors on jumpers and through bulkhead adapters
- Clean SC, ST, FC, LC, MU, and MPO connectors
- Clean a variety of contaminants

Cleaning saves time and money! Over 85% of network failures can be traced back to dirty and damaged connectors. The foolproof way to avoid these outages is to inspect and clean every connector, every time - without fail. You should even inspect new ones right out of the box. Proper fiber hygiene can extend the life of connectors and reduces replacement costs. FCP Cleaning Kits from AFL offer a complete selection of fiber optic cleaning products for field cleaning of connector end-faces in a convenient carry case.

FCP1 kits consist of a wall or rack mountable carry case, FCC2 Fiber Connector Cleaner and Preparation Fluid, CCT Connector Cleaning Tips, Cletop-SB, and color-coded instructions.

FCP2 kits include FCC2 Fiber Connector Cleaner and Preparation Fluid, FCC3 Debris Destroyer® Fiber Cleaning Pen, WFW FiberWipes™, Cletop SB, One-Click Cleaners for SC, ST, FC, LC/MU, MPO connectors, and a field portable duffel bag.

FCP3 kits include FCC2 Fiber Connector Cleaner and Preparation Fluid, FCC3 Debris Destroyer® Fiber Cleaning Pen, CCT Connector Cleaning Tips, Cletop-SB, One-Click Cleaners for SC, ST, FC, LC/MU, MPO connectors, and an easy-access soft carry case.

Cleaning Kits

Ordering Information

FCP1 WALL/RACK MOUNTABLE FIELD PORTABLE CLEANING KITS	AFL NO.		
	FCP1-00-0901	FCP1-00-0907	FCP1-00-0914
CONTENTS / ITEMS DESCRIPTION			
FCC2 Fiber Connector Cleaner And Preparation Fluid (Can)	◆	◆	◆
CCTS-12 (for 1.25 mm ferrule) Connector Cleaning Tips		◆	◆
CCTS-25 (for 2.5 mm ferrule) Connector Cleaning Tips	◆	◆	◆
CCTP-25 (for all connectors) Connector Cleaning Tips	◆	◆	◆
CCTX-MT (for MTP, MPO, MPX connectors) Connector Cleaning Tips		◆	
Cletop-S, Type B with White Tape	◆	◆	◆
Color-coded Instructions	◆	◆	◆
Wall/Rack Mountable Carry Case	◆	◆	◆

FCP2 FIELD PORTABLE DUFFLE BAG CLEANING KITS	AFL NO.	
	FCP2-10-0900	FCP2-00-0901
CONTENTS / ITEMS DESCRIPTION		
FCC2 Fiber Connector Cleaner and Preparation Fluid (Can)	◆	◆
FCC3 Debris Destroyer® Fiber Cleaning Pen	◆	◆
WFW FiberWipes™	◆	◆
Cletop-S, Type B with White Tape	◆	◆
One-Click Cleaner SC, ST, FC	◆	◆
One-Click Cleaner MU/LC	◆	◆
One-Click Cleaner MPO		◆
Field Portable Duffle Bag	◆	◆

FCP3 EASY-ACCESS CLEANING KITS	AFL NO.	
	FCP3-00-0900	FCP3-00-0901
CONTENTS / ITEMS DESCRIPTION		
FCC2 Fiber Connector Cleaner And Preparation Fluid (Can)	◆	◆
FCC3 Debris Destroyer® Fiber Cleaning Pen	◆	◆
CCTS-12 (for 1.25 mm ferrule) Connector Cleaning Tips	◆	◆
CCTS-25 (for 2.5 mm ferrule) Connector Cleaning Tips	◆	◆
Cletop-S, Type B with White Tape	◆	◆
One-Click Cleaner SC, ST, FC	◆	
One-Click Cleaner MU/LC	◆	◆
One-Click Cleaner Ultra 2.5 (enlarged cleaning) SC, ST, FC	◆	◆
One-Click Cleaner D-LC, Duplex LC		◆
One-Click Cleaner MPO	◆	◆
Soft Carry Case	◆	◆

Recommended Products



FOCIS Flex & FOCIS Lightning (Multi-fiber) Connector Inspection

- Self-contained, tether-free, hand-held inspection solution
- Auto-focus and auto-centering for fast, easy inspection
- IEC, IPC and user-defined pass/fail analysis
- FOCIS Lightning: extremely fast multi-fiber auto-analysis for datacom and telecom inspection applications



FOCIS WiFi2™ Fiber Optic Connector Inspection

- Trim, lightweight, ergonomic and highly productive tool
- App-based automatic and manual focus; auto-centering after image capture
- One button workflow using rapid LED feedback on probe
- Multi-color LED on probe for fast pass/fail user inspection feedback

Contact Sales@AFLglobal.com to schedule a demonstration or learn how to buy.

Visit www.AFLglobal.com/Clean to learn more about Cleaning Kits.

International Sales and Service Contact Information available at www.AFLglobal.com/Test/Contacts

CleTOP Optical Fiber Connector Cleaner



Features

- Simple push-button shutter application
- Compact lightweight design
- Easily replaceable cost-effective tape cartridges
- Over 400 wipes per tape

Applications

- Ideal for labs, assembly lines, and field use
- Cleans a wide variety of connector types
- Excellent anti-static properties for static sensitive applications

The CleTOP Optical Fiber Connector Cleaner is a rugged palm-sized cleaner that offers exceptional performance with a proven track record. The choice of many leading manufacturers and telecom carriers worldwide for nearly 20 years, CleTOP is a name you can rely on.

CleTOP Options

- CleTOP Series – Original
- CleTOP –S Series - Second generation cleaner offering “Drop-in” replacement tape cartridge and ergonomic design
- Type A & -SA - Designed for single 2.5mm ferrules (SC, FC, ST, & D4)
- Type B & -SB - Cleans SC, SC2, FC, ST®, DIN, D4, MU, LC, MT, MPO/MTP® without pins

Ordering Information

DESCRIPTION	AFL NO.
CLETOP – S SERIES	
CleTOP -SA with Blue Tape	8500-10-0020MZ
CleTOP -SB with Blue Tape	8500-10-0029MZ
CleTOP -SB with White Tape	8500-10-0016MZ
Replacement Tape Type S - Blue	8500-10-0021MZ
Replacement Tape Type S - White	8500-10-0017MZ

DESCRIPTION	AFL NO.
CLETOP ORIGINAL SERIES	
CleTOP Type A with Blue Tape	8500-10-0027MZ
CleTOP Type A with White Tape	8500-10-0011MZ
CleTOP Type B with Blue Tape	8500-10-0028MZ
CleTOP Type B with White tape	8500-10-0014MZ
CleTOP for MT-RJ with pins (White Tape)	8500-10-0032MZ
CleTOP for MPO/MTP with pins (White Tape)	8500-10-0033MZ
Replacement Tape Blue	8500-10-0012MZ
Replacement Tape White	8500-10-0015MZ

Recommended Products

Cleaning Kits

- Complete kits for cleaning variety of connectors
- Includes wet and dry cleaning products
- Convenient refill options

One-Click® Cleaners

- Patented single-action
- Variety of sizes and types
- Low cost per clean

WFW FiberWipes™

- Lint free and fully optical grade
- Robust and tear-resistant
- Softer than traditional cellulose wipes

Contact Sales@AFLglobal.com to schedule a demonstration or learn how to buy.

Visit www.AFLglobal.com/Clean to learn more about CleTOP Optical Fiber Connector Cleaners.

International Sales and Service Contact Information available at www.AFLglobal.com/Test/Contacts

Cleaning Fluids and Wipes

FCC2 Enhanced Fiber Connector Cleaner and Preparation Fluid

Cleaning Supplies



Features

- Not Hazardous/Not Regulated for all modes of transport, including air cargo
- Unique dispenser for use with AFL Connector Cleaning Tips and FiberWipes™
- Dissipates static charge
- Up to 400+ cleanings per can

Applications

- Cleans of all types of connector end-faces
- Cleans bare fiber before field terminating or fusion splicing
- Removes oils, salts, dust, dirt, and uncured epoxies
- Safe on glass, ceramic, metal, plastic optical fiber

FCC2 Enhanced Fiber Connector Cleaner and Preparation Fluid is a nonflammable, environmentally safe, residue-free solvent engineered to clean fiber connector end-faces and bare fiber. The 3-way dispenser provides easy one-handed use as tap dispenser for fiber wipes, a well for CCT Connector Cleaning Tips, and a spray nozzle for larger areas. Packaged in a spill-proof container, it can be shipped with connector cleaning and termination kits providing everything techs need in the field. FCC2 was developed with Micro Care Corporation, a world leader in cleaning solvents.

Ordering Information

DESCRIPTION	AFL NO.
Fiber Connector Cleaner and Preparation Fluid in 3 oz / 85 g can	FCC2-00-0902
Fiber Connector Cleaner and Preparation Fluid , Case of 12 cans	FCC2-00-0903

Recommended Products



FOCIS Flex Connector Inspection

- Self-contained, tether-free, hand-held
- Auto-focus and auto-centering for fast, easy inspection
- IEC, IPC and user-defined pass/fail analysis



One-Click® Cleaners

- Patented single-action
- Variety of sizes and types
- Low cost per clean



Cleto Cleaners

- Simple push-button shutter application
- Easily replaceable cost-effective tape cartridges
- Over 400 wipes per tape

Cleaning Fluids and Wipes

Debris Destroyer® Fiber Cleaning Pen



Features

- Precise applicator tip for controlled cleaning
- Eliminates electrostatic charge
- Designed for use with One-Click® Cleaners, FiberWipes™, CleanWipes™
- Safe for plastic components

Applications

- Cleaning fiber optic connector end-faces and bare fiber
- Wet to dry cleaning with wipes and One-Click cleaners
- Ideal for bare fiber preparation prior to fusion splicing
- Remove dirt, dust, oils, and other debris from fiber optic components

The Debris Destroyer is a cleaning pen for fiber optic connectors and bare fiber. It can be used for controlled application of cleaning fluid to cassette cleaners and wipes. AFL offers multiple products that can be used with the Debris Destroyer, including CLETOP-S, OPTIPOP-R, FiberWipe, and CleanWipe. The Debris Destroyer can also be used to moisten the tip of One-Click cleaners, turning them into a wet cleaning solution for tough end-face contamination.

Ordering Information

DESCRIPTION	AFL NO.
Debris Destroyer Fiber Cleaning Pen, 9 grams/0.32 oz.	FCC3-00-PEN1

Recommended Products



FOCUS Flex Connector Inspection

- Self-contained, tether-free, hand-held
- Auto-focus and auto-centering for fast, easy inspection
- IEC, IPC and user-defined pass/fail analysis



CleTOP Cleaners

- Simple push-button shutter application
- Easily replaceable cost-effective tape cartridges
- Over 400 wipes per tape



One-Click® Cleaners

- Patented single-action
- Variety of sizes and types
- Low cost per clean

Cleaning Fluids and Wipes

Optical Cloth Wipes

Cleaning Supplies



FiberWipes

Features

- Lint free and fully optical grade
- Robust and tear-resistant
- Softer than traditional cellulose wipes

Applications

- Cleaning optical fibers prior to termination or splicing
- Cleaning fiber optic connector ferrule end-faces
- Cleaning lenses, mirrors, and other optical surfaces
- Use for wet cleaning with FCC2 Connector Cleaning Fluid or FCC3 Fiber Cleaning Pen

Specifically designed to lift and trap common contaminants found in fiber optic installations, AFL wipes provide superior cleaning results because they are made from material that is stronger, softer, and more absorbent than traditional cellulose wipes. Packaged in a clean room, the fabric is optical-quality grade and comes in two convenient form factors and are perfect additions to both tool kits and test kits.

WFW FiberWipes™

- Rugged 90-wipe mini-tub ideal for laboratory and field use
- Hexagonal cover minimizes rolling distance when dropped
- Solvent safe – wipes may be moistened to provide wet / dry cleaning

Ordering Information

DESCRIPTION	AFL NO.
FiberWipes – 90 optical quality wipes per tub, (1 tub)	9000-03-0025MZ
FiberWipes – case of 24 mini-tubs (2160 total wipes, 90 wipes per mini-tub)	9000-03-0026MZ

Recommended Products



FOCIS Flex Connector Inspection

- Self-contained, tether-free, hand-held
- Auto-focus and auto-centering for fast, easy inspection
- IEC, IPC and user-defined pass/fail analysis



Cletop Cleaners

- Simple push-button shutter application
- Easily replaceable cost-effective tape cartridges
- Over 400 wipes per tape



One-Click® Cleaners

- Patented single-action
- Variety of sizes and types
- Low cost per clean

Contact Sales@AFLglobal.com to schedule a demonstration or learn how to buy.

Visit www.AFLglobal.com/Clean to learn more about Cleaning Fluids and Wipes.

International Sales and Service Contact Information available at www.AFLglobal.com/Test/Contacts

NEW

Push-Type Cleaners

One-Click® Cleaners

Features

- Patented single-action cleaning in a small ergonomic design
- Variety of sizes and types for different connector styles
- Cleans connectors in both jumpers and bulkhead adapters
- Low cost per clean

Applications

- Removing oil, dust, and dirt without damaging delicate fiber end-faces
- Both dry and wet cleaning (add cleaning fluid)
- Clean connectors in tight spaces
- Field or laboratory use

One-Click Cleaner

Easy-to-use solution for cleaning fiber optic connectors on jumpers and in adapters. Since over 85% of network outages are attributed to dirty and/or damaged connectors, it is critical to clean every connector! The patented One-Click Cleaner uses the mechanical push action to advance an optical grade cleaning tape while the cleaning tip is rotated to ensure the fiber end-face is effectively, but gently, cleaned. It is a favorite of field technicians for its ease of use, durability, effectiveness, and small size.

One-Click® Cleaner PRO - The One-Click Cleaner PRO is a high-performance cleaner built for speed and efficiency. It features an integrated guide cap design that reduces cleaning time up to 50% by eliminating constant switching of caps for cleaning the ferrule end-face on connectors, in or out of bulkhead adapters. The One-Click Cleaner Pro boasts over 775 cleaning cycles in an ergonomic push-type cleaner, which is a significant increase from the previous model's 500 clean limitation. Designed to meet the needs of data centers, factories, and FTTH environments, One-Click Cleaner PRO optimizes optical connectivity, reduces downtime, and improves efficiency, making it an essential tool for fiber connector cleaning.

Compact One-Click Cleaner Mini - Offering the same technology and performance as the original, the One-Click Cleaner mini enables cleaning connectors in tighter places. Its smaller size also makes it a great addition to test kits and cleaning kits. The mini One-Click Cleaners come in both 100+ or 500+ cleans per unit.

One-Click Ultra Cleaner 2.5 - The One-Click Ultra Cleaner 2.5 has an enlarged cleaning area to clean more of the connector end-face. Cleaning up to a 2 mm diameter area of the connector end-face, the One-Click Ultra Cleaner 2.5 is a superior cleaner for SC, ST, and FC connectors.

One-Click Cleaner D-LC (Duplex LC) - The One-Click Cleaner D-LC cuts cleaning time in half by effectively cleaning both connectors of a duplex LC connector simultaneously. Available in a long-lasting 500+ clean pen shape.



SC PRO LC PRO SC/ST/FC MU/LC



Mini-100 SC, ST, FC Mini-100 MU/LC



Ultra 2.5 D-LC

Push-Type Cleaners

One-Click® Cleaners

One-Click Cleaner MPO and MPO-16

The One-Click Cleaner MPO/MPO-16 is a revolutionary push-type cleaner that simplifies cleaning of the ferrule end-face of MPO/MTP® connector. The One-Click MPO-16 cleans 16-fiber MPO/MTP connectors, both pinned (male) and socketed (female). MPO-16 is used with IEEE 802.3bs 400G trunk cabling with each fiber carrying 25 Gbps data signals (400GBASE-SR16 for example), among other applications.



MPO

MPO-16

One-Click Cleaner CS/MDC Duplex

The One-Click Cleaner CS/MDC cuts cleaning time in half by effectively cleaning both connectors of a duplex CS/MDC at one time.

One-Click Cleaner SN Duplex

The One-Click Cleaner SN cuts cleaning time in half by effectively cleaning both connectors of a duplex SN at one time.

One-Click Cleaner HOC

The Hardened Outdoor Connector (HOC) One-Click Cleaner is an essential cleaning tool for OptiTap®, TITAN RTD®, TRIDENT®, and SC connectors. The new design of the HOC Cleaner allows it to be used for Plug/Receptacle without the need for the conventional guide cap.



CS, MDC

SN Duplex

HOC

Ordering Information

DESCRIPTION	AFL NO.
One-Click Cleaner SC, ST, FC (500+ cleans)	8500-05-0001MZ
One-Click Cleaner MU/LC (500+ cleans)	8500-05-0002MZ
One-Click Cleaner ODC, outdoor connector (500+ cleans)	8500-05-0004MZ
One-Click Cleaner Mini-100 SC, ST, FC (100+ cleans)	8500-05-0005MZ
One-Click Mini-100 MU/LC (100+ cleans)	8500-05-0006MZ
One-Click Cleaner Mini-500 SC, ST, FC (500+ cleans)	8500-05-0009MZ
One-Click Cleaner Mini-500 MU/LC (500+ cleans)	8500-05-0010MZ
One-Click Ultra Cleaner 2.5 (enlarged cleaning) SC, ST, FC (500+ cleans)	8500-05-0007MZ
One-Click Cleaner D-LC, Duplex LC (2 x 500+ cleans)	8500-05-0008MZ
One-Click Cleaner MPO (500+ cleans)	8500-05-0030MZ
One-Click Cleaner MPO-16 (500+ cleans)	8500-05-0013MZ
One-Click Cleaner MT-RJ (500+ cleans)	8500-05-0031MZ
One-Click Cleaner M20, 2.0 mm ferrule (500+ cleans)	8500-05-0014MZ
One-Click Cleaner CS, MDC Duplex (500+ cleans)	8500-05-0015MZ
One-Click Cleaner SN Duplex (500+ cleans)	8500-05-0016MZ
One-Click Cleaner HOC, Hardened Optic Connectors (500+ cleans)	8500-05-0018MZ
One-Click Cleaner SC Pro (775+ cleans)	8500-05-PRO-SC
One-Click Cleaner LC Pro (775+ cleans)	8500-05-PRO-LC
BOXES OF 5 UNITS	
One-Click Cleaner SC, ST, FC (box of 5 units)	8500-05-0021MZ
One-Click Cleaner MU/LC (box of 5 units)	8500-05-0022MZ
One-Click Cleaner Mini-100 SC, ST, FC (box of 5 units)	8500-05-0025MZ
One-Click Cleaner Mini-100 MU/LC (box of 5 units)	8500-05-0026MZ
One-Click Ultra Cleaner 2.5 SC, ST, FC (box of 5 units)	8500-05-0027MZ
One-Click Cleaner MPO-16 (box of 5 units)	8500-05-0023MZ

Push-Type Cleaners

NEOCLEAN Cleaners



NEOCLEAN-E Models (E1, E2, E3)



NEOCLEAN-M

Features

- Push action
- Replaceable cleaning cartridge - 750 cleaning per cartridge (NEOCLEAN-E)
- Low cost per clean

Applications

- Cleans connectors on jumpers or in adapters
- SC, FC, ST, E2000, LC, and MU connectors
- MPO and MTP connectors
- Suitable for field or laboratory use

NEOCLEAN-E uses a push action to clean contamination from the end-face of connectors on jumpers or in adapters. The replaceable cleaning cartridge can perform 750 cleans, reducing cleaning cost.

NEOCLEAN-M is designed for cleaning MPO and MTP multi-fiber connectors used in data centers and other high-density optical networks. It uses a one-push operation, which simplifies cleaning of the ferrule end-face of both MPO and MTP connectors and connectors in adapters.

Ordering Information

MODEL	APPLICABLE CONNECTORS & DESCRIPTION	# OF CLEANS	AFL NO.
NEOCLEAN-E1	For MU, LC with UPC/APC polishes	750+	8500-15-0900MZ
NEOCLEAN-E2	For SC,FC with UPC/APC polishes; OptiTap		8500-15-0901MZ
NEOCLEAN-E3	For SC, ST, FC, E2000 with UPC/APC polishes; OptiTap		8500-15-0902MZ
NEOCLEAN-M	For MPO/MTP	600+	8500-15-0909MZ

Recommended Products



FOCIS Flex Connector Inspection

- Self-contained, tether-free, hand-held
- Auto-focus and auto-centering for fast, easy inspection
- IEC, IPC and user-defined pass/fail analysis



Cletop Cleaners

- Simple push-button shutter application
- Easily replaceable cost-effective tape cartridges
- Over 400 wipes per tape



FCC2 Cleaning Fluid

- Unique dispenser for use with AFL Connector Cleaning Tips and FiberWipes
- Dissipates static charge
- Up to 400+ cleanings per can

Contact Sales@AFLglobal.com to schedule a demonstration or learn how to buy.

Visit www.AFLglobal.com/Clean to learn more about Push-Type Cleaners.

International Sales and Service Contact Information available at www.AFLglobal.com/Test/Contacts

NEW



MMC-16

MMC-24

Push-Type Cleaners

One-Click® Cleaner MMC

Features

- Cleans high-density, low-insertion-loss pinned or unpinned MMC connectors
- Patented single-action cleaning in a small ergonomic design
- Precise mechanical action delivers consistent cleaning results
- Automatic tape advance ensures each clean is performed with fresh cleaning tape

Applications

- Clean MMC-16 and MMC-24 connectors on jumpers and in adapters
- Maximum density, pre-terminated cabling installations
- High fiber count data center interconnects
- Structured cabling

Designed to clean Very Small Form Factor (VSFF) MMC multi-fiber connectors used in Data Centers and other high density optical networks, the new One-Click Cleaner MMC is a revolutionary push-type cleaner, which simplifies cleaning of the ferrule end-face of both MMC exposed connectors and connectors in adapters.

Ease of use - With its patented push-action cleaning, the One-Click Cleaner MMC removes dirt, dust, and contaminants with just one click. Its straightforward use requires no training. Simply insert and click to clean MMC connectors

Maximized efficiency - By utilizing the one-click design, technicians can speed through the cleaning process. No manual wipes or wet solvents are needed. The mechanical push action instantly advances the optical grade cleaning tape while the cleaning tip is rotated to ensure the MMC end-face is effectively, but gently, cleaned.

Increased uptime - With the move to next-gen VSFF data-center connectivity, it is essential to maintain connections for optimal performance. Using the specialized One-Click Cleaner MMC, technicians can clean MMC-16 and MMC-24 connectors easily and effectively in 1/2 the time as traditional methods leading to reliable signal transmission and extended lifespan of the connector.

Ordering Information

DESCRIPTION	# OF CLEANS	AFL NO.
One-Click Cleaner MMC for MMC-16 Connectors	500+ cleans	8500-05-MMC16
One-Click Cleaner MMC for MMC-24 Connectors	500+ cleans	8500-05-MMC24

Push-Type Cleaners

One-Click® Cleaner MMC

PRODUCT HIGHLIGHTS



Easy-to-use



Purpose-designed tool



Speeds cleaning process



Hand-held cleaner



No training required

Consistent cleaning results
Automatic tape advance ensures each clean is performed with fresh cleaning tape

500+ cleans
Over 500 cleans in both One-Click Cleaner MMC-16 or MMC-24 versions.

Extended nozzle
Easy reach for dense MMC connectors

Ergonomic design
One-handed operation makes cleaning quick and easy

Must-have tool for field use
A favorite of field technicians for its ease of use, durability, effectiveness, and small size

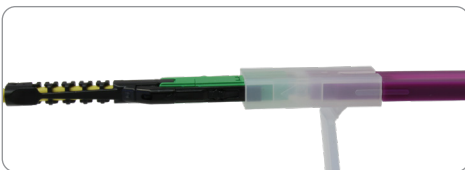

Cleaning MMC-16 connector on jumper

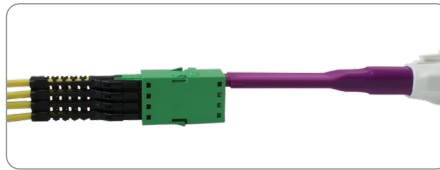

Cleaning MMC-16 connector in adapters



Recommended Products



FOCIS Lightning®2 Multi-Fiber Optic Connector Inspection System

- Self-contained, tether-free, hand-held
- Auto-focus and auto-centering for fast, easy inspection
- IEC, IPC and user-defined pass/fail analysis



Cletop Cleaners

- Simple push-button shutter application
- Easily replaceable cost-effective tape cartridges
- Over 400 wipes per tape



FCC2 Cleaning Fluid

- Unique dispenser for use with AFL Connector Cleaning Tips and FiberWipes
- Dissipates static charge
- Up to 400+ cleanings per can

Contact Sales@AFLglobal.com to schedule a demonstration or learn how to buy.

Visit www.AFLglobal.com/Clean to learn more about Push-Type Cleaners.

International Sales and Service Contact Information available at www.AFLglobal.com/Test/Contacts

ROGUE® OLTS Certifier

Measure insertion loss, return loss and length on multimode and single-mode fiber optic networks



Features

- Bi-directional testing on up to 2 fibers at once
- Pass/Fail certification to ISO/IEC/TIA/IEEE and custom test limits
- Automatic dual-wavelength identification (Wave ID)
- Test cord reference wizard and built-in encircled flux compliance
- Integrated power meter and visual fault identifier
- 12-fiber MPO certification with optional Multi-fiber switch (MFS)
- Reporting with TRM® PC software and optional cloud-based workflow integration with aeRos®

Applications

- Certify Tier 1 networks to industry standards
- Test LAN structured cabling and data center networks with single fiber (LC, SC, FC, ST) and multi-fiber (MTP/MPO) connectivity
- Test access, metro and core networks
- Document network installations

AFL's ROGUE OLTS Certifier measures insertion loss, return loss, and length bi-directionally to industry standards on both multimode and single-mode networks. ROGUE OLTS Certifier is offered as a matched pair of units, with each unit featuring 4 test ports. Two of the ports combine a light source and power meter to enable bi-directional testing on single or dual fibers. The other two ports are a dedicated power meter and a visual fault identifier (VFI) to help troubleshoot networks.

ROGUE OLTS Certifier is available as an intelligent base (iB1) model with an integrated display. It can provide either single-fiber testing on quad SM/MM wavelengths (850/1300/1310/1550 nm) or single and dual-fiber testing at 1310/1550 nm.

Test Management and Reporting Software: All ROGUE OLTS Certifier kits include a basic license for Test Result Manager (TRM® 3.0) providing data processing and reporting locally via a PC. The optional aeRos® Pro test management software provides cloud-based workflow integration to remotely build projects, assign jobs, collect results, track progress and generate reports.

ROGUE® OLTS Certifier

Specifications^a

OLTS	MULTIMODE	SINGLE-MODE
Emitter Type	LED	Laser
Wavelengths	850 ±30 nm; 1300 ±20 nm	1310, 1550 ±20 nm
Safety Class	Class I FDA 21 CFR 1040.10 and 1040.11, IEC EN60825-1: 2007-03	
Detector Type	InGaAs	InGaAs
Launch Condition	Encircled Flux Compliant ^b	N/A
Length Measurement Range	5 km	200 km (SMF28e)
Power Measurement Range	+3 to -60 dBm	+3 to -60 dBm
Output Power	-24/-23 dBm, 62.5/50 µm	-3 dBm, 9 µm
Stability ^c	±0.1 dB over 1 hour ±0.15 dB over 8 hours	±0.1 dB over 1 hour ±0.15 dB over 8 hours
Wave ID Transmit	Yes	Yes
Tone Generation	330 Hz, 1 kHz, 2 kHz	330 Hz, 1 kHz, 2 kHz
Input Connector	Interchangeable connector adapter (LC standard, SC, ST, FC optional)	

OPTICAL POWER METER (OPM)	
Calibrated Wavelengths	850, 1300, 1310, 1490, 1550, 1625, 1650 nm
Detector Type	InGaAs PIN, 2 mm diameter
Measurement Range	+3 to -70 dBm
Wave ID	Automatically synchronizes and measures 1, 2 or 3 λ Wave ID combinations
Range	+3 to -40 dBm @ 850 nm; +3 to -50 dBm @ 1300, 1310, 1550 nm
Tone Detect	Auto-detects 270, 330 Hz; 1, 2 kHz tones;
Accuracy	±5% @-10 dBm
Linearity	±0.1 dB (-3 to -40 dBm); ±0.25 dB (-40 to -50 dBm)
Measurement Units	Power in dBm, nW, µW, mW; Loss in dB; 0.01 dB resolution

VISUAL FAULT LOCATOR (VFL)	
Emitter Type	Visible red laser, 650 ±20 nm
Safety Class	Class II FDA 21 CFR 1040.10 and 1040.11, IEC EN60825-1: 2007-03
Output Power (nominal)	0.8 mW into single-mode fiber
Modes	CW and 2 Hz flashing

GENERAL	iB1
Size	23.5 x 13.3 x 7.6 cm (9.25 x 5.25 x 3.0 in)
Weight	1.56 kg (3.46 lb)
Operating Temperature	-10 °C to +50 °C, 0 to 90 % RH (non-condensing)
Storage Temperature	-20 °C to +60 °C, 0 to 90 % RH (non-condensing)
Power	Rechargeable Li-Ion or AC power adapter
Battery Life	>8 hours continuous testing

Notes:

- a. All specifications valid at 23°C ±2°C (73.4°F ±3.6°F) unless otherwise specified.
- b. TIA-526-14-B, ISO/IEC 14763-3 and IEC 61280-4-1.
- c. After 15 minutes warm-up.

ROGUE® OLTS Certifier

Ordering Information

Each ROGUE OLTS Certifier kit includes two (2) of each: ROGUE iB1 Base, kit-specific ROGUE Modules, battery, AC charger, carry strap, carry case. Each ROGUE OLTS Certifier kit includes (1) One-Click Cleaner SC/2.5 mm, (1) One-Click Cleaner LC/1.25 mm, switchable test port adapters and test accessories.

DESCRIPTION	CONTAINS (two of each)	AFL NO.
ROGUE OLTS Certifier kit with iB1 Base, Quad SM/MM	ROGUE iB1 Base, Quad SM/MM Module, battery, AC charger, adjustable carry strap, carry case	RGK-CERT01B1
ROGUE OLTS Certifier kit with iB1 Base, Dual SM ports	ROGUE iB1 Base, Dual Ports SM Module, battery, AC charger, adjustable carry strap, carry case	RGK-CERT03B1

ROGUE Hardware and Accessories

DESCRIPTION	AFL NO.
ROGUE OLTS with iB1 Base; contains ROGUE iB1 Base, Dual Ports SM Module, battery, AC charger, adjustable carry strap	RGK-OLTS03B1
ROGUE iB1, Intelligent Base; contains ROGUE iB1 Base, battery, AC charger, adjustable carry strap	RG-B01
ROGUE OLTS Certifier Quad Module; contains Quad Module; test port adapters: (2) SC for OLS port, SC and LC for OPM port	RG-1100-Q01
ROGUE OLTS Certifier SM Module; contains SM Module; test port adapters (2) SC for OLS port, SC and LC for OPM port	RG-1100-S01-D
ROGUE Kit Carry Case	RGA-CASE-01
ORL Referencing Mandrel	5400-00-0200
Adjustable Carry Strap	RGA-STRAP-01
AC charger for cB1 Base	4050-00-0132PR
AC charger for iB1 Base	4050-00-0918PR
Reference cable, SC/UPC-LC/UPC, SMF28E/E+, 2 m	8700-00-0081
Reference cable, SC/APC-LC/UPC, SMF, 2 m	8700-00-0050
Reference grade cable, SC/UPC-LC/UPC, MMF, 50 μm, OM4, 2 mm, Red, 2 m	8700-04-0007MR



ROGUE OLTS Certifier kit with iB1 Bases

ROGUE® OLTS Certifier

ROGUE OLTS Certifier Adapters

DESCRIPTION	TEST PORT USAGE	AFL NO.
FC	OLS	2900-50-0002MR
SC	OLS	2900-50-0003MR
ST	OLS	2900-50-0004MR
LC	OLS	2900-50-0006MR
FC	OPM	2900-52-0001MR
SC	OPM	2900-52-0002MR

DESCRIPTION	TEST PORT USAGE	AFL NO.
ST	OPM	2900-52-0003MR
LC	OPM	2900-52-0004MR
2.5 mm Universal	OPM	2900-52-0005MR
1.25 mm Universal	OPM	2900-52-0006MR
2.5 mm Universal	VFL	2900-50-0007MR
1.25 mm Universal	VFL	2900-50-0010MR

Test Management and Reporting Software

DESCRIPTION	AFL NO.
TRM 3.0 upgrade from Basic to Advanced software	TRM3-UGRADE
TURBO App (Android Google play)	Free Download

Recommended Products

aeros®

Cloud-based Test Management and Reporting

- Seamless interaction with Android™ applications
- Run reports at the push of a button

Qualifications

CATEGORY	REGULATION/STANDARD	QUALIFICATION
CE Marking	EU	Compliant to relevant EU Directives on health, safety, and environmental protection, and certified with CE marking
Safety /EMC /EMI	IEC	Compliant to IEC 61010-1 for safety requirements for electrical equipment
	EN	Compliant to EN 61010-1 for safety requirements for electrical equipment
	IEC	Compliant to IEC 61326-1 for EMC requirements for electrical equipment
	EN	Compliant to EN 61326-1 for EMC requirements for electrical equipment
	EN	Compliant to EN 55011 for EMC requirements for industrial, scientific and medical equipment
	FCC	Compliant to code of federal regulations FCC 47 CFR 15 on unlicensed transmissions
	FDA	Compliant to code of federal regulations FDA 21 CFR 1040.10 and 1040.11 on laser products
	IEC	Compliant to IEC 60825-1 for safety of laser products
RoHS	EU	Compliant to EU regulations Directive 2011/65/EU (RoHS 2) and Directive 2015/863 (RoHS 3)
Test Method	TIA	Compliant to TIA-568.3-D for test and measurement requirements for premises optical fiber cabling and components
	IEC	Compliant to IEC 11801 for test and measurement requirements for optical fiber cabling for use within premises
	EN	Compliant to EN 50173 for test and measurement requirements for optical fiber cabling for use within premises
	AS/NZS	Compliant to AS/NZS 3080 for test and measurement requirements for optical fiber cabling for use within premises
	TIA	Compliant to TIA-526-7 for test procedures for installed optical fiber cable plant
	TIA	Compliant to TIA-526-14 for test procedures for installed optical fiber cable plant
	IEC	Compliant to IEC 14763-3 for systems and methods for the inspection and testing of installed optical fiber cabling
	AS/NZS	Compliant to AS/NZS 14763.3 for systems and methods for the inspection and testing of installed optical fiber cabling
	IEC	Compliant to IEC 61280-4-1 for test procedures for installed optical fiber cable plant
	IEC	Compliant to IEC 61280-4-2 for test procedures for installed optical fiber cable plant

Contact Sales@AFLglobal.com to schedule a demonstration or learn how to buy.

Visit www.AFLglobal.com/Test to learn more about ROGUE OLTS Certifier.

International Sales and Service Contact Information available at www.AFLglobal.com/Test/Contacts

Multi-Fiber Switch



Multi-fiber Switch paired with ROGUE

Features

- Stand-alone operation as well as pairing with other testers including OTDRs and OLTS
- 12-fiber switching capability
- Dual wavelength, single-mode or multimode
- Rechargeable battery with USB port charging/communication

Applications

- Converts a single port tester into a multi-fiber tester utilizing your existing OLTS, OTDR, and VFL test equipment
- Efficiently test 12-fiber links without disconnecting/reconnecting
- Bi-directional testing without moving cables
- Certify MPO links to industry standards including base 8 applications

The density demands of today's networks are driving more demand for multi-fiber connectivity. As the adoption of multi-fiber connectors becomes more prevalent in data centers, the ability to test these types of connections accurately and quickly has become even more critical.

AFL's Multi-Fiber Switch enables the testing of MPO/MTP[®]-terminated cables. The switch allows you to utilize a single piece of test equipment to verify some or all of the fibers in a multi-fiber connector in a single test, saving you both time and money.

AFL's Multi-Fiber Switch is compatible with your AFL FlexScan FS200 and FS300 series OTDRs and ROGUE[®] OLTS Certification equipment. The switch can be manually configured or remotely controlled via USB from both FlexScan OTDRs and ROGUE OLTS.

Specifications^a

OPTICAL		
Wavelength	1310/1550 nm, SM dual-wavelength	850/1300 nm, MM dual-wavelength
Insertion Loss	2.8 dB typ. – 3.3 dB max.	1.8 dB typ. – 2.3 dB max.
Optical Return Loss (ORL)	50 dB min.	—
Fiber Length	4.4 ± 0.5 m	
Optical Length Uniformity	± 0.15 m	
GENERAL		
Power	Li-Ion battery or USB interface	
Battery Life	1000 hours continuous operation	
Weight	0.3 kg (0.66 lb)	
Dimensions	12.9 x 6.9 x 3.1 cm (5.1 x 2.7 x 1.2 in)	
Operating Temperature	-20 °C to +60 °C, 0 to 90 % RH (non-condensing)	
Storage Temperature	-20 °C to +70 °C, 0 to 90 % RH (non-condensing)	

Notes:

a. All specifications valid at 23 °C ± 2 °C (73.4 °F ± 3.6 °F) unless otherwise specified.

Multi-Fiber Switch

Ordering Information

DESCRIPTION	AFL NO.
Multi-fiber Switch, 12 fibers SM, APC-SC, MPO fiber ring (non-pinned), soft case	MFS-12-SM-ASC-FR
Multi-fiber Switch, 12 fibers SM, APC-SC, soft case	MFS-12-SM-ASC
Multi-fiber Switch, 12 fibers SM, UPC-SC, soft case	MFS-12-SM-USC
Multi-fiber Switch, 12 fibers MM, UPC-SC, soft case	MFS-12-MM-USC

ROGUE MFS Certification Add-on Kits

Each Multi-Fiber Switch Certification Add-on kit include (2) Multi-Fiber Switches, (2) 6 in. USB-USB mini cables, (2) key up / key down MPO-MPO mating adapters, (2) MFS carry holsters, (1) One-Click Cleaner MPO, (2) MFS kit carry cases, test cords and mating adapters (see table below).

ADD-ON KIT	CONTAINS (ea.)			AFL NO.
	12F MFS SWITCH	REFERENCE TEST CORDS		
		SC-SC, 0.3 (m)	12F MPO-MPO, 2 (m)	
SM, SC/UPC-MPO/APC	(2) SM, SC/UPC-MPO/APC	(2) SM	(2) SM, type A unpinned; (2) SM, type A pinned/unpinned; (1) SM, type B unpinned	MPO-SM-CERT-ADD
MM, SC/UPC-MPO/UPC	(2) MM, SC/UPC-MPO/UPC	(2) MM	(2) OM4, type A unpinned; (2) OM4, type A pinned/unpinned; (1) OM4, type B unpinned	MPO-MM-CERT-ADD

MFS Multi-Fiber Switch OTDR Add-on Kit

Single-mode and multimode Multi-Fiber Switches (MFS) are available to accelerate OTDR testing of MPO-connectorized, multi-fiber cables. OTDR MFS Add-on Kits include (1) MFS with MPO connector, (1) single-fiber Fiber Ring to connect OTDR to the switch, plus (1) MPO Fiber Ring.

CONTAINS (ea.)			AFL NO.
12F MFS SWITCH	FIBER RING	MPO FIBER RING	
MFS-12-SM-ASC, SM, SC/APC-MPO/APC pinned	SM, 150 m, SC-ASC or ASC-ASC (depending on OTDR connector)	12F, 61m, MPO/APC-unpinned to MPO; Select pinned or unpinned network MPO connector	MPO-SM-OTDR-ADD
MFS-12-MM-USC, MM, SC/UPC-MPO/UPC pinned	OM3/4/5-compatible, SC-SC, 150 m	12F, 61m, MPO-unpinned to MPO; Select pinned or unpinned network MPO connector	MPO-MM-OTDR-ADD

Recommended Products



ROGUE® OLTS Certifier

- Bi-directional testing on up to 2 fibers at once
- Pass/Fail certification to ISO/IEC/TIA/IEEE and custom test limits
- Automatic dual-wavelength identification (Wave ID)



FlexScan® FS300 (quad) and FS200 (single-mode) OTDRs

- SmartAuto® 1-button automated testing for fast results
- LinkMap® color-coded icons for easy troubleshooting
- Flexpress® mode (FS200) completes OTDR test in <5 seconds!
- Integrated Source, Power Meter and VFL

Qualifications

CATEGORY	REGULATION/STANDARD	QUALIFICATION
CE Marking	EU	Compliant to relevant EU Directives on health, safety, and environmental protection, and certified with CE marking
Safety	EN	Compliant to EN 61326-1 for EMC requirements for electrical equipment
	EN	Compliant to EN 55011 for EMC requirements for industrial, scientific and medical equipment
RoHS	EU	Compliant to EU regulations Directive 2011/65/EU (RoHS 2) and Directive 2015/863 (RoHS 3)

Contact Sales@AFLglobal.com to schedule a demonstration or learn how to buy.

Visit www.AFLglobal.com/Test to learn more about Multi-Fiber Switch.

International Sales and Service Contact Information available at www.AFLglobal.com/Test/Contacts

FlowScout® SE100 Single-Ended Test Set

Quickly and Easily Verify Continuity and Insertion Loss From One End

US Patent Pending



FlowScout SE100 with 1430 nm Wavelength Optical Reflector

Features

- Verifies fiber continuity and insertion loss at 1430 nm from a single end
- Excess reflection (low ORL) detection at 1550 nm
- Live fiber detection and reporting
- Built-in optical continuous wave (CW) reflectometer
- Combines light source and power meter into a single unit

Applications

Used to verify:

- FTTH continuity and insertion loss during service activation or troubleshooting
- FTTA continuity and insertion loss between Distribution Unit (DU) and Radio Unit (RU)
- Fiber backhaul continuity and insertion loss to demarcation point

AFL's FlowScout SE100 is designed to verify fiber continuity and measure insertion loss to the end of fibers terminated with AFL's 1430 nm Wavelength Optical Reflectors. When a reflector is detected, the FlowScout SE100 immediately reports its presence (confirming continuity to the reflector) and measures insertion loss to the reflector at 1430 nm wavelength. The reflector is near-transparent to PON and other wavelengths, allowing it to remain installed during network operation.

Reduce cost: Combining an optical light source and power meter into one low-cost test set, the FlowScout SE100 enables a single technician to verify continuity and measure insertion loss, reducing equipment costs by over 38% and labor costs by over 50%.

Shorten test time and eliminate setup errors: Traditional two-ended testing requires equipment configuration and test coordination. FlowScout SE100 eliminates time-consuming setup and technician coordination time. It also speeds up testing by reducing visits to subscriber premises, demarcation points, and cell tower climbs.

Enhance customer experience: The FlowScout SE100 eliminates the need for onsite troubleshooting of FTTH drop issues. All testing can be completed from a distribution panel or splitter, eliminating technician time at the subscriber premises and overcoming scheduling and access challenges for both subscribers and service providers.

Increase technician safety: Repeated tower climbs for troubleshooting FTTA fibers are eliminated by using the FlowScout SE100 to test from the ground to optical reflectors installed at the Radio Unit.

Ensure integrity of test results: FlowScout SE100 alerts the user when excess reflection or a live signal is present on the tested network. Reflection issues from damaged, open, mismatched, or dirty connectors often result in poor network performance. FlowScout SE100 immediately alerts the user and displays ORL when excess reflection is present.

Complements subscriber-installed ONT initiatives: Reducing the need for FTTH premises visits, the FlowScout SE100 solution supports service provider goals to reduce costs by adopting a subscriber self-install ONT methodology.

FlowScout® SE100 Single-Ended Test Set

Example Applications

Optical Loss Testing

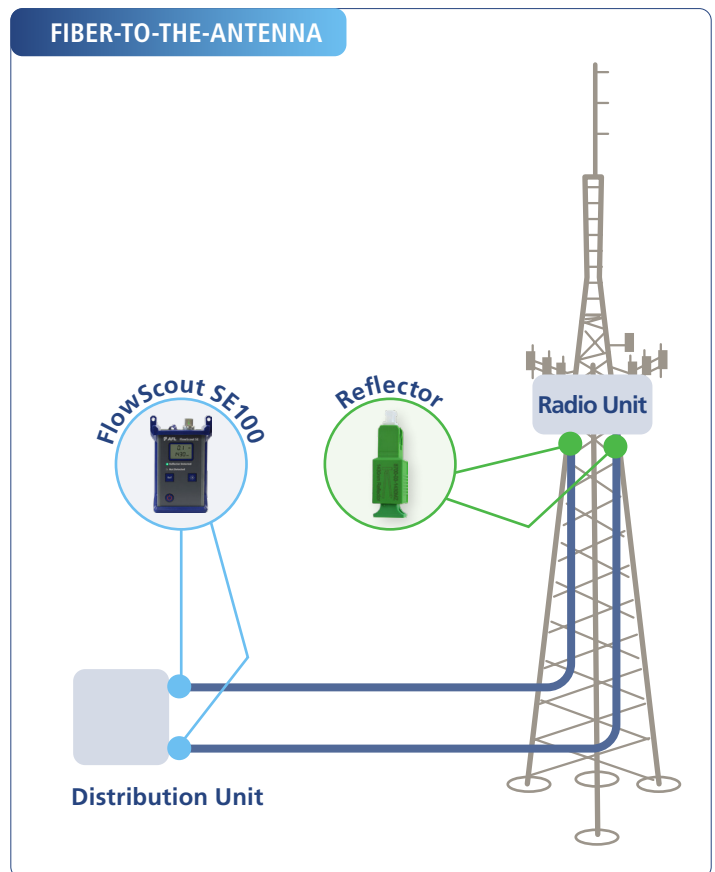
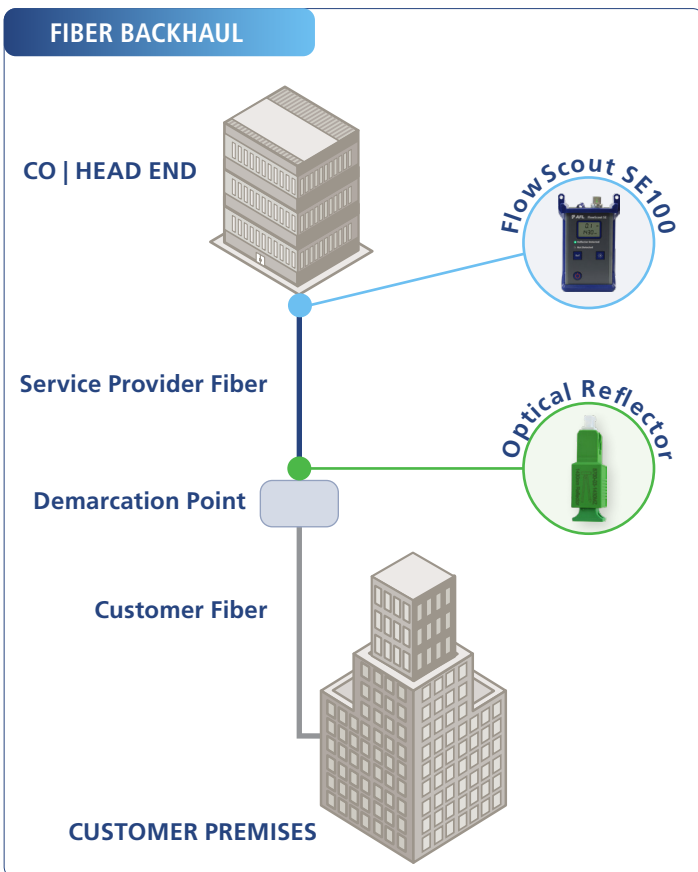
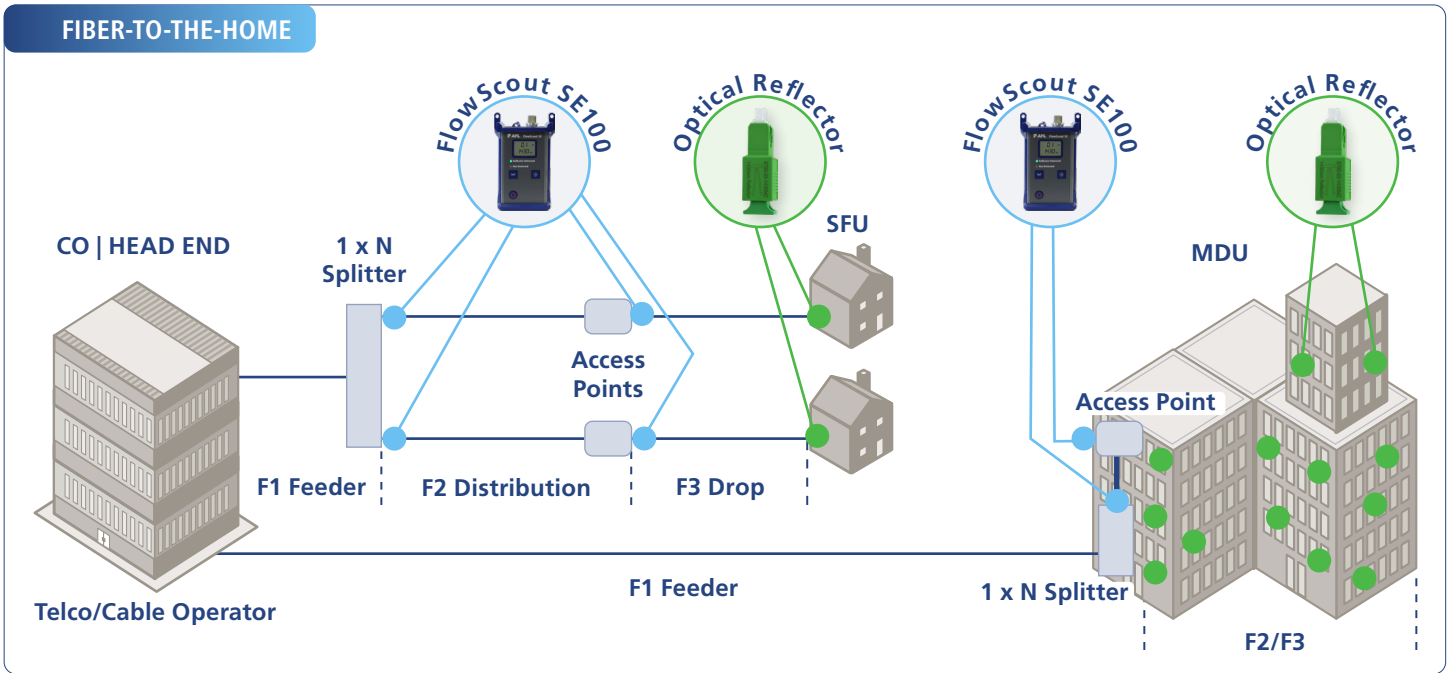

FlowScout® SE100 Single-Ended Test Set

PRODUCT HIGHLIGHTS



Easy to Use



Brightness Control



Battery Operated



Handheld



USB Power Port / Software upgrades

Single SC/APC Connection
Simply plug in the fiber connector and get readings in >5 sec!

Large LCD display
Multi-function screen clearly shows all measurements and prompts

Clear color-coded readings
LED indicators allow you to view if reflector is detected in seconds

Easy, one-handed operation
Easily one hand operation. Large buttons for easy operation

Durable design for field use
Protective rubber boot for in-field durability and reliability



Specifications^a

OPTICAL	
Emitter Type	Laser
Safety Class ^b	Class I
Fiber Type	Single-mode; compatible with all G.652, G.655, and G.657 SMF
Calibrated Wavelengths	1430 and 1550 nm
Center Wavelength	1430 ±5 nm; 1550 ±20 nm
Spectral Width (FWHM)	≤5 nm
Output Power Level	-1 to -4 dBm CW
Output Power Stability	±0.1 dB over 1 hour (after 1 minute warmup)
Detector Type	InGaAs PIN
Detection Range	Reflector detected / not detected up to 20 km (18 mi) with optical loss ≤9 dB at 1430 & 1550 nm and 1550 nm ORL ≥25 dB
Insertion Loss Measurement Range	At least 10 dB when ORL ≥25 dB @1550 nm At least 6 dB when ORL in range 14 – 20 dB @ 1550 nm
Loss Accuracy	±1.0 dB for loss in range 0 to 6 dB
Loss Resolution	0.1 dB
Measurement Units	Loss in dB; ORL in dB
GENERAL	
Size (in boot)	14.0 x 8.1 x 3.8 cm (5.5 x 3.2 x 1.5 in)
Weight	≤0.3 kg (≤0.7 lb)
Operating Temperature	-10 °C to +50 °C, 0 to 95% RH (non-condensing)
Storage Temperature	-30 °C to +60 °C, 0 to 95% RH (non-condensing, batteries installed)
Battery Power	2 x AA alkaline batteries; user-replaceable
AC Power	Optional external AC power supply (100-240 VAC, 50-60 Hz; 5VDC @2A)
Battery life	Typical 120 hrs, minimum 75 hrs (continuous operation, backlight off)
Display	Backlit monochrome LCD
Shock and vibration	Drop test, 1 m, 6 planes
Optical port	Fiber-coupled, 2.5 mm ceramic ferrule plus SC/APC connector adapter
Dust Cap	Captive dust cap mounts over SC/APC connector adapter

Notes:

- a. All specifications valid at 25°C unless otherwise specified.
- b. FDA 21 CFR 1040.10 and 1040.11; IEC 60825-1:2014

FlowScout® SE100 Single-Ended Test Set

Ordering Information

FlowScout SE100 kits include the FlowScout SE100 test set, SC/APC to SC/APC patch cord to connect to network under test, reference 1430 nm Wavelength Optical Reflector, wrist strap, and Quick Reference Guide in a convenient soft carry case.

DESCRIPTION	AFL NO.
FlowScout SE100 Single-Ended Test Set	SE100-00-0901PR

Accessories

DESCRIPTION	AFL NO.
ACCESSORIES INCLUDED WITH SE100-00-0901PR KIT	
1430 nm Wavelength Optical Reflector, SC/APC, female-to-male, plug type	8700-03-1430MZ
Universal flip-top dust cap for UCI outputs	8800-00-0072PR
Single-mode test jumper, SC/APC to SC/APC, 2 m, 3 mm jacketed	8700-00-0218MR
Wrist atrap	1400-05-0230PZ
Soft carry case with strap	1400-01-0107MZ
ADDITIONAL OPTIONAL ACCESSORIES	
SC/APC adapter for optical port	2900-50-0011MR

DESCRIPTION	AFL NO.
USB – Micro-B cable, 5 pin, 6 ft	6000-00-0031MR
AC Adapter (shipped with one power plug of customer choice; select one from plugs listed below!)	4050-00-0034MR
<ul style="list-style-type: none"> 4050-00-0030EUMR EU Power Plug for AC charger 4050-00-0030USMR US power plug for AC charger 4050-00-0030SAAMR CN/AUS power plug for AC charger 4050-00-0030UKMR UK power plug for AC charger 	
FlowScout SE100-facing APC female to APC male field-replaceable Port Saver SMF	2900-58-0001MR
One-Click Cleaner Mini 500 SC, ST, FC; 500+ Cleans	8500-05-0009MZ

Recommended Products



FOCIS Flex Connector Inspection

- Self-contained, tether-free, hand-held inspection solution
- Auto-focus and auto-centering for fast, easy inspection
- IEC, IPC and user-defined pass/fail analysis



One-Click® Cleaners

- Patented single-action
- Variety of sizes and types
- Low cost per clean



VF14 Visual Fault Identifier

- Eye-safe Class 3R visible red laser source, 650 nm
- Output power of $\leq 5.0 \mu\text{W}$ with 10 km range
- Universal connector interface for quick connection

Qualifications

CATEGORY	REGULATION/STANDARD	QUALIFICATION
CE Marking	EU	Compliant to relevant EU Directives on health, safety, and environmental protection, and certified with CE marking
UKCA Marking	UK	Compliant to relevant UK Directives on health, safety, and environmental protection, and certified with the UKCA marking
Safety/EMC/EMI	IEC	Compliant to IEC 61010-1 for safety requirements for electrical equipment
	EN	Compliant to EN 61010-1 for safety requirements for electrical equipment
	IEC	Compliant to IEC 61326-1 for EMC requirements for electrical equipment
	EN	Compliant to EN 61326-1 for EMC requirements for electrical equipment
	EN	Compliant to EN 55011 for EMC requirements for industrial, scientific and medical equipment
	FDA	Compliant to code of federal regulations FDA 21 CFR 1040.10 and 1040.11 on laser products
	IEC	Compliant to IEC 60825-1 for safety of laser products
RoHS	EU	Compliant to EU regulations Directive 2011/65/EU (RoHS 2) and Directive 2015/863 (RoHS 3)
Generic Requirement	IEC	Compliant to IEC 61315 for requirements on calibration of fibre-optic power meters

Contact Sales@AFLglobal.com to schedule a demonstration or learn how to buy.

Visit www.AFLglobal.com/Test to learn more about complementary AFL fiber optic test and inspection products.

International Sales and Service Contact Information available at www.AFLglobal.com/Test/Contacts

FlowScout® Through-Mode PON Optical Power Meter

US Patent 9,602,200 and US Patent 10,771,153

Optical Loss Testing



Features

- Detect multiple wavelengths automatically - NO setup required!
- Detects GPON, XGS-PON, and Video signals all at once
- Rugged and water resistant, IP54 rating
- Field-swappable connector adapters
- Large color touchscreen display daylight viewable
- Rechargeable Li-Polymer battery

Applications

- Detects and measures PON upstream and downstream signals
- PON network activation
- BPON, EPON, GPON, 10G-EPON, XG-PON, XGS-PON, Video network verification and troubleshooting
- Evaluate PON power level Pass/Fail based on limits

AFL is a trusted supplier of optical testing equipment with more than 30 years of experience and tens of thousands of units in the field. AFL's full range of N.I.S.T. traceable power meters are used for testing single-mode and/or multimode fiber networks.

Designed for all: AFL's power meters are designed to meet the demands in an outside plant environment. The FlowScout Through-Mode PON Power Meter (TPPM) easily withstands a one-meter drop and has splash resistant controls that are easy to use, even with gloves on.

Flexible and efficient: A range of field-swappable output adapters support multiple connector styles and enables access for easy cleaning. The efficient design ensures a long run time from its rechargeable Li-Polymer battery and includes an auto-off feature to save power.

Stores test results: The built-in File Management system allows technicians to organize test results into multiple files and transfer them via USB to a PC for analyzing, generating reports, and printing. The FlowScout's QR code feature can easily collect and transfer test data via any smart devices.

FlowScout® Through-Mode PON Optical Power Meter

Specifications^a

OPTICAL				
MODEL		TPPM-XG		
Upstream	Wavelength	1270 nm	1310 nm	
	Measurement Range	-28 to +13 dBm	-28 to +13 dBm	
Downstream	Wavelength	1490 nm	1550 nm	1577 nm
	Measurement Range	-50 to +13 dBm	-35 to +26 dBm	-50 to +17 dBm
Accuracy ^b		±0.50 dB @0 dBm		
Resolution		0.01 dB		
Insertion Loss		1.7 dB Typical		
Inline ORL		55 dB typical		
Measurement Units		dBm, µW		

GENERAL	
Power	Rechargeable Li-Polymer battery
Adapter Caps	SC APC standard, LC APC available
Battery Life	>8 hours
Recharge time	~4 hours
Operating Temperature	-10 °C to 50 °C, 95 % RH (non-condensing)
Storage Temperature	-20 °C to 60 °C, 95 % RH (non-condensing)
Size (H x W x D)	17.1 x 10.4 x 4.6 cm (6.75 x 4.1 x 1.8 in)
Weight	0.59 kg (1.3 lb)

Notes:

- a. All specifications valid at 25°C unless otherwise specified.
- b. Accuracy was measured at 25 °C and -10 dBm per N.I.S.T. standards.

Ordering Information

All models include PON optical power meter, rechargeable batteries, SC/APC adapter cap, two SC/APC-SC/APC jumpers, USB-A to USB-C cable for charging and data transfer, AC plug, and carry case. Quick reference guide is available at www.AFLglobal.com.

DESCRIPTION	AFL NO.
FlowScout PON optical power meter XGAPON/XGSPON	TPPM-XG
INCLUDED ACCESSORIES	
(2) SC/APC to SC/APC Test Jumpers, 2 m	8700-00-0090MR
USB-A to USB-C Charge and Data Transfer Cable	6000-00-0036MR
AC Adapter	4050-00-0034MR
One-Click® Cleaner Mini-500 SC, ST, FC (500+ cleans)	8500-05-0009MZ
AFL ships one power plug (of customer choice) along with the order. Please select one out of the four plugs listed below.	
EU Power Plug for AC charger	4050-00-0034EUMR
US power plug for AC charger	4050-00-0034USMR
CN/AUS power plug for AC charger	4050-00-0034SAAMR
UK power plug for AC charger	4050-00-0034UKMR

Optical Loss Testing

FlowScout® Through-Mode PON Optical Power Meter

Recommended Products



Optical Light Sources

- Encircled Flux Compliant
- 5-Year Product Warranty
- Integrated LED and Laser light sources



One-Click® Cleaners

- Patented single-action
- Variety of sizes and types
- Low cost per clean



VF14 Visual Fault Identifier

- Eye-safe Class 3R visible red laser source, 650 nm
- Output power of ≤ 5.0 mW with 10 km range
- Universal connector interface for quick connection

Qualifications

CATEGORY	REGULATION/STANDARD	QUALIFICATION
CE Marking	EU	Compliant to relevant EU Directives on health, safety, and environmental protection, and certified with CE marking
UKCA Marking	UK	Compliant to relevant UK Directives on health, safety, and environmental protection, and certified with the UKCA marking
Safety/EMC/EMI	IEC	Compliant to IEC 61010-1 for safety requirements for electrical equipment
	EN	Compliant to EN 61010-1 for safety requirements for electrical equipment
	IEC	Compliant to IEC 61326-1 for EMC requirements for electrical equipment
	EN	Compliant to EN 61326-1 for EMC requirements for electrical equipment
RoHS	EU	Compliant to EU regulations Directive 2011/65/EU (RoHS 2) and Directive 2015/863 (RoHS 3)
Test Method	TIA	Compliant to TIA-568.3-D for test and measurement requirements for premises optical fiber cabling and components
	IEC	Compliant to IEC 11801 for test and measurement requirements for optical fiber cabling for use within premises
	EN	Compliant to EN 50173 for test and measurement requirements for optical fiber cabling for use within premises
	AS/NZS	Compliant to AS/NZS 3080 for test and measurement requirements for optical fiber cabling for use within premises
	TIA	Compliant to TIA-526-7 for test procedures for installed optical fiber cable plant
	TIA	Compliant to TIA-526-14 for test procedures for installed optical fiber cable plant
	IEC	Compliant to IEC 14763-3 for systems and methods for the inspection and testing of installed optical fiber cabling
	AS/NZS	Compliant to AS/NZS 14763.3 for systems and methods for the inspection and testing of installed optical fiber cabling
	IEC	Compliant to IEC 61280-4-1 for test procedures for installed optical fiber cable plant
IEC	Compliant to IEC 61280-4-2 for test procedures for installed optical fiber cable plant	
Generic Requirement	IEC	Compliant to IEC 61315 for requirements on calibration of fibre-optic power meters

Contact Sales@AFLglobal.com to schedule a demonstration or learn how to buy.

Visit www.AFLglobal.com/Test to learn more about FlowScout PON optical power meters.

International Sales and Service Contact Information available at www.AFLglobal.com/Test/Contacts

Optical Loss Test Kits



SMLP5-5 Kit

Features

- Rugged, dependable, and backed by industry-best 5-year warranty
- Wave ID tests up to three wavelengths simultaneously - slashing test time
- Field-swappable connector adapters for maximum flexibility
- Long battery life from globally available AA batteries

Applications

- Certify multimode and single-mode links per TIA/EIA standards
- Passive Optical Networks (PON) testing
- Certification report generation with TRM® 2.0 software
- Fiber identification for splicing and continuity checking

Optical Loss Test Sets (OLTS) provide the most accurate method for determining the total loss of a link. AFL’s OLTS have been an industry favorite for over 30 years with more than 100,000 units shipped. Leading service providers and enterprise customers rely on AFL’s OLTS for their ruggedness, reliability, and best-in-the-industry 5-year warranty.

An OLTS test is performed with a light source on one end of the fiber sending a continuous wave at specific wavelength(s) and a power meter on the opposite end measuring the light received. The loss measured is compared to the loss budget, which is usually calculated prior to installation, and reflects the industry standards used to ensure that the link can meet its application requirements.

OLTS are mainly used to certify multimode and single-mode links, test Passive Optical Networks (PONs), identify fibers before splicing, and to ensure network continuity.

Designed for use in outside plant environments: AFL OLTS are extremely rugged and withstand one-meter drops, have splash resistant controls that are easy to use with gloves on, and the field-swappable connector adapters provide flexibility and access for cleaning optical ports at time of test.

Test faster with fewer errors: AFL’s Wave ID increases test speed by performing simultaneous multi-wavelength testing that cuts loss measurement time in half or more. AFL’s automatic wavelength identification eliminates setup errors and simplifies coordination between users at opposite ends of fiber.

Optical Loss Test Kits

Specifications^a

OPTICAL SPECIFICATIONS - POWER METERS			
MODEL	OPM5-4D	OPM5-3D, OPM4-3D	OPM5-2D
Calibrated Wavelengths	850, 980, 1300, 1310, 1490, 1550, 1625 nm	850, 1300, 1310, 1490, 1550, 1625 nm	850, 1300, 1310, 1490, 1550 nm
Detector Type	Filtered InGaAs	InGaAs	Germanium (Ge)
Measurement Range	+26 to -50 dBm	+10 to -75 dBm	+6 to -60 dBm
Tone Detect Range	+6 to -30 dBm +6 to -25 dBm for 850 nm	+10 to -50 dBm +10 to -45 dBm for 850 nm	+6 to -50 dBm +6 to -45 dBm for 850 nm
Wavelength ID Range	+6 to -30 dBm +6 to -25 dBm for 850 nm	+10 to -50 dBm +10 to -45 dBm for 850 nm	+6 to -50 dBm +6 to -45 dBm for 850 nm
Accuracy	±0.1 dB (typical); ±0.25 dB		
Resolution	0.01 dB		
Measurement Units	dB, dBm, µW		

OPTICAL SPECIFICATIONS: OLS7 MODELS			
MODEL	OLS7-FTTH (Single Port)		
Wavelength (±20 nm)	1310 nm	1490 nm	1550 nm
Spectral Width	5 nm	3 nm	5 nm
Emitter Type	Laser		
Safety Class	Class I FDA 21 CFR 1040.10 and 1040.11, IEC 60825-1: 2007-03		
Output Power	-5 dBm (typical), 9/125 fiber		
Output Stability	±0.05 dB over 1 hour (after 15 minutes warm-up) ±0.1 dB over 8 hours (after 15 minutes warm-up)		
Tone Output	270 Hz, 330 Hz, 1 kHz, 2 kHz		

OPTICAL SPECIFICATIONS: OLS4, OLS2-DUAL & OLS1-DUAL MODELS						
MODEL	OLS4 (MM Optical Port)		OLS4 (SM Optical Port)		OLS2-DUAL (Single Port)	
Wavelength	850 ±30 nm	1300 +30/-20 nm	1310 ±20 nm	1550 ±20 nm	1310 ±20 nm	1550 ±20 nm
Spectral Width	45 nm (typ)	120 nm (typ)	5 nm (max)	5 nm (max)	5 nm (max)	
Emitter Type	LED		Laser		Laser	
Safety Class	Class I FDA 21 CFR 1040.10 and 1040.11, IEC 60825-1: 2007-03					
Output Power	>-20 dBm, 62.5 µm multimode ^b		0 dBm, 9 µm single-mode		0 dBm, 9 µm single-mode ^c	
Output Stability	±0.1 dB over 8 hours (after 5 minutes warm-up)		±0.05 dB over 1 hour (after 15 minutes warm-up) ±0.1 dB over 8 hours (after 15 minutes warm-up)			
Tone Output	N/A		2 kHz		270 Hz, 330 Hz, 1 kHz, 2 kHz	

GENERAL SPECIFICATIONS: ALL OPM AND OLS MODELS	
Available Adapters	SC FC, ST, LC
Power	2 AA batteries
Operating Temperature	-10 °C to 50 °C, 90 % RH (non-condensing)
Storage Temperature	-30 °C to 60 °C, 90 % RH (non-condensing)
Size (H x W x D)	14.0 x 8.1 x 3.8 cm (5.5 x 3.2 x 1.5 in)
Weight	0.29 kg (0.65 lb)

Notes:

- All specifications valid at 25°C unless otherwise specified.
- May be used to test 50 or 62.5 µm fiber with supplied mandrels.
- Output power will be approximately 3 dB less if a 50 µm mandrel-wrapped jumper is used instead of a 62.5 µm mandrel-wrapped jumper.
- Adjustable 2 dB.

Optical Loss Test Kits

Ordering Information

Test kits include light source, power meter, protective rubber boots, AA batteries, adapter caps, and carry case.

AFL NO.	POWER METER	LIGHT SOURCE	FIBER TYPE	LOSS MEASUREMENTS (nm)					DYNAMIC RANGE (dB)	TRM® 2.0 PC REPORTING
				850	1300	1310	1490	1550		
SLP5-6	OPM5-3D	OLS2-DUAL	SM			◆		◆	70 ^b	◆
SLP5-FTTH	OPM5-4D	OLS7-FTTH	SM			◆	◆	◆	45 ^b	◆
SMLP5-5	OPM5-2D	OLS4	MM SM	◆	◆	◆		◆	40 @ 850/1300 nm ^a 60 @ 1310/1550 nm ^b	◆

Notes:

- a. On 62.5/125 µm multimode fiber.
- b. On 9/125 µm single-mode fiber.

Part Number – Connector Specification

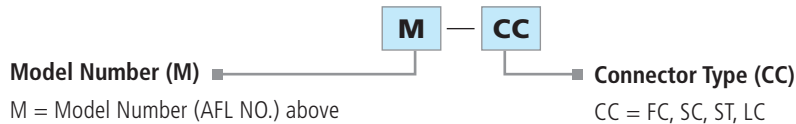

Examples: SMLP5-5-SC => (SMLP5-5 Test Kit with SC adapters)

Accessories

DESCRIPTION	AFL NO.
LIGHT SOURCE CONNECTOR ADAPTERS	
FC connector adapter	2900-50-0002MR
SC connector adapter	2900-50-0003MR
ST connector adapter	2900-50-0004MR
LC connector adapter	2900-50-0006MR
POWER METER CONNECTOR ADAPTERS	
FC connector adapter	8800-00-0200
SC connector adapter	8800-00-0209
ST connector adapter	8800-00-0202
LC connector adapter	8800-00-0225
MULTIMODE TEST CORDS (50/125 µm – 2 meters)	
FC/FC	8700-00-0093
SC/ST	8700-00-0064
SC/SC	8700-00-0065
LC/LC	8700-00-0082
SINGLE-MODE TEST CORDS (9/125 µm – 2 meters)	
FC/FC	8700-00-0005
FC/ST	8700-00-0016
ST/ST	8700-00-0017
SC/SC	8700-00-0018
FC/SC	8700-00-0021
SC/ST	8700-00-0022
SC/LC	8700-00-0046
FC/LC	8700-00-0071
LC/LC	8700-00-0097

DESCRIPTION	AFL NO.
MATING ADAPTERS (Bulkheads)	
FC/FC	8400-00-0004MR
SC/SC	8400-00-0045MR
ST/ST	8400-00-0020
LC/LC	8400-00-0075
CLEANING SUPPLIES	
One-Click Cleaner SC/ST/FC	8500-05-0001MZ
One-Click Cleaner LC	8500-05-0002MZ
Cletop –SB Cassette Cleaner	8500-10-0016MZ
Cletop –SB Refill Cartridge	8500-10-00017MZ

Optical Loss Test Kits

Test Management and Reporting Software

DESCRIPTION	AFL NO.
TRM® 2.0 with Basic License (OTDR Trace/OLTS Viewer, Batch Editor and Reports), USB delivery	TRM-00-0900PR

Recommended Products



OFI-BIPM Optical Fiber Identifier

- World class signal sensitivity
- Trigger lock, positive stop for optimum detection
- Integrated optical power meter option



One-Click® Cleaners

- Patented single-action
- Variety of sizes and types
- Low cost per clean

Qualifications

CATEGORY	REGULATION/STANDARD	QUALIFICATION
CE Marking	EU	Compliant to relevant EU Directives on health, safety, and environmental protection, and certified with CE marking
Safety/EMC/EMI	IEC	Compliant to IEC 61010-1 for safety requirements for electrical equipment
	EN	Compliant to EN 61010-1 for safety requirements for electrical equipment
	IEC	Compliant to IEC 61326-1 for EMC requirements for electrical equipment
	EN	Compliant to EN 61326-1 for EMC requirements for electrical equipment
	EN	Compliant to EN 55011 for EMC requirements for industrial, scientific and medical equipment
	FDA	Compliant to code of federal regulations FDA 21 CFR 1040.10 and 1040.11 on laser products
RoHS	IEC	Compliant to IEC 60825-1 for safety of laser products
	EU	Compliant to EU regulations Directive 2011/65/EU (RoHS 2) and Directive 2015/863 (RoHS 3)
Test Method	TIA	Compliant to TIA-568.3-D for test and measurement requirements for premises optical fiber cabling and components*
	IEC	Compliant to IEC 11801 for test and measurement requirements for optical fiber cabling for use within premises*
	EN	Compliant to EN 50173 for test and measurement requirements for optical fiber cabling for use within premises*
	AS/NZS	Compliant to AS/NZS 3080 for test and measurement requirements for optical fiber cabling for use within premises*
	TIA	Compliant to TIA-526-7 for test procedures for installed optical fiber cable plant
	TIA	Compliant to TIA-526-14 for test procedures for installed optical fiber cable plant*
	IEC	Compliant to IEC 14763-3 for systems and methods for the inspection and testing of installed optical fiber cabling*
	AS/NZS	Compliant to AS/NZS 14763.3 for systems and methods for the inspection and testing of installed optical fiber cabling*
	IEC	Compliant to IEC 61280-4-1 for test procedures for installed optical fiber cable plant*
	IEC	Compliant to IEC 61280-4-2 for test procedures for installed optical fiber cable plant
Generic Requirement	IEC	Compliant to IEC 61315 for requirements on calibration of fibre-optic power meters

* A complementary encircled flux mode conditioner may be needed to comply with encircled flux launch conditions for testing multimode optical fiber cabling and components

Contact Sales@AFLglobal.com to schedule a demonstration or learn how to buy.

Visit www.AFLglobal.com/Test to learn more about OLTS kits.

International Sales and Service Contact Information available at www.AFLglobal.com/Test/Contacts

Encircled Flux (EF) Compliant Light Sources and Test Kits



Features

- EF Complaint light sources and test kits per TIA 526-14-B and IEC 61280-4-1 Ed. 2.0
- EF Compliant by design – no additional equipment required
- Industry-leading 5-year warranty
- Wave ID for error free testing of multiple wavelengths simultaneously
- Test cords included

Applications

- MMF and SMF testing requiring EF Compliant equipment
- Passive Optical Network (PON) testing
- Certify multimode and single-mode links to TIA/EIA standards
- Certification report generation with TRM® 2.0 software

Designed for use in outside plant environments: AFL OLTS are extremely rugged and withstand one-meter drops, have splash resistant controls that are easy to use with gloves on, and the field-swappable connector adapters provide flexibility and access for cleaning optical ports at time of test.

Test faster with fewer errors: AFL's Wave ID increases test speed by performing simultaneous multi-wavelength testing that cuts loss measurement time in half or more. AFL's automatic wavelength identification eliminates setup errors and simplifies coordination between users at opposite ends of fiber.

Encircled Flux (EF) Compliant Light Sources and Test Kits

Specifications ^a

OPTICAL SPECIFICATIONS - POWER METERS	
MODEL	OPM5-2D
Calibrated Wavelengths	850, 1300, 1310, 1490, 1550 nm
Detector Type	Germanium (Ge)
Measurement Range	+6 to -60 dBm
Tone Detect Range	+6 to -50 dBm +6 to -45 dBm for 850 nm
Wavelength ID Range	+6 to -50 dBm +6 to -45 dBm for 850 nm
Accuracy	±0.25 dB
Resolution	0.01 dB
Measurement Units	dB, dBm, µW

OPTICAL SPECIFICATIONS: OLS4 AND OLS1-DUAL MODELS				
MODEL	OLS4 EF (MM Optical Port)		OLS4 EF (SM Optical Port)	
Wavelength	850 ±30 nm	1300 +30/-20 nm	1310 ±20 nm	1550 ±20 nm
Spectral Width	45 nm (typ)	120 nm (typ)	5 nm (max)	5 nm (max)
Emitter Type	LED		Laser	
Safety Class	Class I FDA 21 CFR 1040.10 and 1040.11, IEC 60825-1: 2007-03			
Output Power	≥ -24 dBm, 50 µm multimode		0 dBm, 9 µm single-mode	
Output Stability	±0.1 dB over 8 hours (after 5 minutes warm-up)		±0.05 dB over 1 hour (after 15 minutes warm-up) ±0.1 dB over 8 hours (after 15 minutes warm-up)	
Tone Output	N/A		2 kHz	

GENERAL SPECIFICATIONS: ALL OPM AND OLS MODELS	
Available Adapters	SC FC, ST, LC
Power	2 AA batteries
Operating Temperature	-10 °C to 50 °C, 90 % RH (non-condensing)
Storage Temperature	-30 °C to 60 °C, 90 % RH (non-condensing)
Size (H x W x D)	14.0 x 8.1 x 3.8 cm (5.5 x 3.2 x 1.5 in)
Weight	0.29 kg (0.65 lb)

Notes:

a. All specifications valid at 25°C unless otherwise specified.

Ordering Information

Encircled Flux (EF) Compliant Light Sources

Since adoption by the IEC, Encircled Flux (EF) multimode launch requirements are increasingly specified into fiber loss testing job requirements. Meeting EF specification requires technicians use EF qualified test sets. It is important to note IEC 61280-1-4 and TIA-568-14-B, specify EF multimode launch conditions at the end of an EF qualified Reference Grade Test Cord (RGTC) – not directly out source test port. Thus, EF compliance requires an EF Light Source and RGTC used together. AFL offers OLS4 MM/SM light source with designed in Encircled Flux (EF) optics supplied with EF qualified RGTC. OLS4 EF is supplied with one multimode RGTC and one standard 9/125 single-mode test cord.

WAVELENGTHS	TEST CORDS INCLUDED	AFL NO.
MM 850/1300 nm SM 1310/1550 nm	(1) RGTC, 50 µm, MM, 2-meter (1) 9/125 µm, SM, 2-meter	OLS4-EF

Encircled Flux (EF) Compliant Light Sources and Test Kits

Ordering Information

Encircled Flux (EF) Compliant Test Kits

AFL EF compliant loss test kits include:

Multimode Test Ports:

- Light Source with designed in Encircled Flux (EF) optics paired with one EF qualified RGTC.
- 50/125 μm receive test cord

Single-mode Test Ports:

- Light Source with two 9/125 μm test cords (launch / receive)

POWER METER	LIGHT SOURCE	FIBER TYPE	WAVELENGTH (nm)	DYNAMIC RANGE (dB)	AVAILABLE CONNECTORS		INCLUDED 2-METER TEST CORDS		AFL NO.
					SOURCE PORT	TEST CORD	LAUNCH (μm)	RECEIVE (μm)	
OPM5-2D	OLS4-EF	MM SM	850, 1300 1310, 1550	36 @ 850/1300 nm 60 @ 1310/1550 nm	FC, SC	FC, SC, ST, LC	MM: RGTC, 50/125 SM: 9/125	MM: 50/125 SM: 9/125	SMLP5-5-EF

Accessories

DESCRIPTION	AFL NO.
LIGHT SOURCE CONNECTOR ADAPTERS	
FC connector adapter	2900-50-0002MR
SC connector adapter	2900-50-0003MR
ST connector adapter	2900-50-0004MR
LC connector adapter	2900-50-0006MR
POWER METER CONNECTOR ADAPTERS	
FC connector adapter	8800-00-0200
SC connector adapter	8800-00-0209
ST connector adapter	8800-00-0202
LC connector adapter	8800-00-0225
REFERENCE GRADE LAUNCH CORDS (RGLC) (50/125 μm – 2 meters)	
FC to FC	8700-04-0001MR
FC to SC	8700-04-0002MR
FC to LC	8700-04-0003MR
FC to ST	8700-04-0004MR
SC to FC	8700-04-0005MR
SC to SC	8700-04-0006MR
SC to LC	8700-04-0007MR
SC to ST	8700-04-0008MR
MULTIMODE TEST CORDS (50/125 μm – 2 meters)	
FC/FC	8700-00-0093
SC/ST	8700-00-0064
SC/SC	8700-00-0065
LC/LC	8700-00-0082

DESCRIPTION	AFL NO.
SINGLE-MODE TEST CORDS (9/125 μm – 2 meters)	
FC/FC	8700-00-0005
FC/ST	8700-00-0016
ST/ST	8700-00-0017
SC/SC	8700-00-0018
FC/SC	8700-00-0021
SC/ST	8700-00-0022
SC/LC	8700-00-0046
FC/LC	8700-00-0071
LC/LC	8700-00-0097
MATING ADAPTERS (Bulkheads)	
FC/FC	8400-00-0004MR
SC/SC	8400-00-0045MR
ST/ST	8400-00-0020
LC/LC	8400-00-0075
CLEANING SUPPLIES	
One-Click Cleaner SC/ST/FC	8500-05-0001MZ
One-Click Cleaner LC	8500-05-0002MZ
CleTOP –SB Cassette Cleaner	8500-10-0016MZ
CleTOP –SB Refill Cartridge	8500-10-00017MZ

Encircled Flux (EF) Compliant Light Sources and Test Kits

Test Management and Reporting Software

DESCRIPTION	AFL NO.
TRM® 2.0 with Basic License (OTDR Trace/OLTS Viewer, Batch Editor and Reports), USB delivery	TRM-00-0900PR

Recommended Products



OFI-BIPM Optical Fiber Identifier

- World class signal sensitivity
- Trigger lock, positive stop for optimum detection
- Integrated optical power meter option



One-Click® Cleaners

- Patented single-action
- Variety of sizes and types
- Low cost per clean

Qualifications

CATEGORY	REGULATION/STANDARD	QUALIFICATION
CE Marking	EU	Compliant to relevant EU Directives on health, safety, and environmental protection, and certified with CE marking
Safety/EMC/EMI	IEC	Compliant to IEC 61010-1 for safety requirements for electrical equipment
	EN	Compliant to EN 61010-1 for safety requirements for electrical equipment
	IEC	Compliant to IEC 61326-1 for EMC requirements for electrical equipment
	EN	Compliant to EN 61326-1 for EMC requirements for electrical equipment
	EN	Compliant to EN 55011 for EMC requirements for industrial, scientific and medical equipment
	FDA	Compliant to code of federal regulations FDA 21 CFR 1040.10 and 1040.11 on laser products
RoHS	IEC	Compliant to IEC 60825-1 for safety of laser products
	EU	Compliant to EU regulations Directive 2011/65/EU (RoHS 2) and Directive 2015/863 (RoHS 3)
Test Method	TIA	Compliant to TIA-568.3-D for test and measurement requirements for premises optical fiber cabling and components*
	IEC	Compliant to IEC 11801 for test and measurement requirements for optical fiber cabling for use within premises*
	EN	Compliant to EN 50173 for test and measurement requirements for optical fiber cabling for use within premises*
	AS/NZS	Compliant to AS/NZS 3080 for test and measurement requirements for optical fiber cabling for use within premises*
	TIA	Compliant to TIA-526-7 for test procedures for installed optical fiber cable plant
	TIA	Compliant to TIA-526-14 for test procedures for installed optical fiber cable plant*
	IEC	Compliant to IEC 14763-3 for systems and methods for the inspection and testing of installed optical fiber cabling*
	AS/NZS	Compliant to AS/NZS 14763.3 for systems and methods for the inspection and testing of installed optical fiber cabling*
	IEC	Compliant to IEC 61280-4-1 for test procedures for installed optical fiber cable plant*
	IEC	Compliant to IEC 61280-4-2 for test procedures for installed optical fiber cable plant
Generic Requirement	IEC	Compliant to IEC 61315 for requirements on calibration of fibre-optic power meters

* A complementary encircled flux mode conditioner may be needed to comply with encircled flux launch conditions for testing multimode optical fiber cabling and components.

Contact Sales@AFLglobal.com to schedule a demonstration or learn how to buy.

Visit www.AFLglobal.com/Test to learn more about Encircled Flux (EF) Compliant Light Sources and Test Kits.

International Sales and Service Contact Information available at www.AFLglobal.com/Test/Contacts

OLS Series Light Sources

5 YEAR WARRANTY



OLS7 Optical Laser Source

Features

- Rugged, dependable, and backed by industry-best 5-year warranty
- Generates up to three Wave ID wavelengths simultaneously - slashing test time
- Field-swappable connector adapters for maximum flexibility
- Long battery life from globally available AA batteries

Applications

- Certify multimode and single-mode links per TIA/EIA standards
- Link loss measurements
- Pair with power meters, OTDRs or OFIs for testing
- Fiber identification for splicing and continuity checking

AFL is a trusted supplier of optical testing equipment with more than 30 years of experience and tens of thousands of units in use in the field. AFL's full range of light sources are used for testing single-mode and/or multimode fiber networks. Sources with wave ID can transmit two or more wavelengths simultaneously – decreasing test time and reducing user errors when paired with AFL wave ID power meters.

Designed for the real world: AFL's light sources were designed to meet the demands of the outside plant environment. They withstand the one-meter drop and have splash resistant controls that are easy to use, even with gloves on.

Flexible and efficient: A range of field-swappable output adapters enables access for cleaning optical ports and supports multiple connector styles. The efficient design provides long test time from globally available AA batteries. External power adapter available for extended testing or lab situations.

Reduce test time and errors: Wave ID (Triple, Dual, or Single) decreases test time while reducing technician errors and CW mode provides continuous output (no encoding).

Supported output modes: Test Tone (2000, 1000, 330, 270 Hz) for use in fiber identification with AFL brand power meters, OTDRs (with fiber end access) or Optical Fiber Identifier (OFI) products for non-intrusive, mid-span testing.

OLS Series Light Sources

OLS Series Models and Applications

MODEL	MM / SM	WAVELENGTHS (nm)	APPLICATIONS
OLS1-Dual	MM	850, 1300	Ethernet, Token Ring, and FDDI Fiber Links
OLS2-Dual	SM	1310, 1550	SM Networks, LAN/WAN Testing
OLS4	MM / SM	850, 1300 / 1310, 1550	Loss Testing of SM/MM networks
OLS7-FTTH	SM	1310, 1490, 1550	FTTH Networks
OLS7-3	SM	1310, 1550, 1625	Telecom & CATV Networks

Specifications ^{a,e}

OPTICAL SPECIFICATIONS: OLS4, OLS2-DUAL & OLS1-DUAL MODELS								
MODEL	OLS1-DUAL (Single Port ^b)		OLS2-DUAL (Single Port)		OLS4 (SM Optical Port)		OLS4 (MM Optical Port)	
Wavelength	850 ±30 nm	1300 +30/-20 nm	1310 ±20 nm	1550 ±20 nm	1310 ±20 nm	1550 ±20 nm	850 ±30 nm	1300 +30/-20 nm
Spectral Width	45 nm (typ)	120 nm (typ)	5 nm (max)		5 nm (max)	5 nm (max)	45 nm (typ)	120 nm (typ)
Emitter Type	LED		Laser		Laser		LED	
Safety Class	Class I FDA 21 CFR 1040.10 and 1040.11, IEC 60825-1: 2007-03							
Output Power	>-20 dBm, 62.5 μm multimode ^c		0 dBm, 9 μm single-mode ^d		0 dBm, 9 μm single-mode		>-20 dBm, 62.5 μm multimode ^c	
Output Stability	±0.1 dB over 8 hours (after 5 minutes warm-up)		±0.05 dB over 1 hour (after 15 minutes warm-up) ±0.1 dB over 8 hours (after 15 minutes warm-up)				±0.1 dB over 8 hours (after 5 minutes warm-up)	
Tone Output	N/A		270 Hz, 330 Hz, 1 kHz, 2 kHz		2 kHz		N/A	

OPTICAL SPECIFICATIONS: OLS7 MODELS						
MODEL	OLS7-FTTH (Single Port)			OLS7-3 (Single Port)		
Wavelength (±20 nm)	1310 nm	1490 nm	1550 nm	1310 nm	1550 nm	1625 nm
Spectral Width	5 nm	3 nm	5 nm	5 nm	5 nm	2 nm
Emitter Type	Laser					
Safety Class	Class I FDA 21 CFR 1040.10 and 1040.11, IEC 60825-1: 2007-03					
Output Power	-5 dBm (typical), 9/125 fiber					
Output Stability	±0.05 dB over 1 hour (after 15 minutes warm-up) ±0.1 dB over 8 hours (after 15 minutes warm-up)					
Tone Output	270 Hz, 330 Hz, 1 kHz, 2 kHz					

GENERAL SPECIFICATIONS: ALL OLS MODELS	
Available Adapters	SC FC, ST, LC
Power	2 AA batteries, optional AC adapter
Battery Life	SM port: 72 hours typical (40 hours minimum). MM port: 30 hours typical (20 hours minimum)
Operating Temperature	-10 °C to 50 °C, 95 % RH (non-condensing)
Storage Temperature	-30 °C to 60 °C, 95 % RH (non-condensing)
Size (H x W x D)	14.0 x 8.1 x 3.8 cm (5.5 x 3.2 x 1.5 in)
Weight	0.29 kg (0.65 lb)

Notes:

- All specifications valid at 25°C unless otherwise specified.
- May be used to test 50 or 62.5 μm fiber with supplied mandrels.
- Output power will be approximately 3 dB less if a 50 μm mandrel-wrapped jumper is used instead of a 62.5 μm mandrel-wrapped jumper.
- Adjustable 2 dB.
- All OLS products come with the UPC optical port.

OLS Series Light Sources

Ordering Information

When ordering, specify connector type at the end of model number (e.g. OLS2-DUAL-SC). All OLS models include protective rubber boot, 2 AA batteries, carry case. AC adapters are available (ordered separately), see table below. Test jumpers and connector adapters are required for operation (purchased separately). Test jumpers with a variety of connector styles and fiber types and adapter caps for most common connectors may be purchased from AFL.

OUTPUT WAVELENGTHS (nm)						OUTPUT PORTS	EMITTER TYPE	WAVE ID TRANSMIT	AVAILABLE CONNECTORS	POWER	AFL NO.
850	1300	1310	1490	1550	1625						
◆	◆					1	LED	◆	FC, SC, ST, LC	(2) AA, AC	OLS1-DUAL
		◆		◆		1	Laser	◆	FC, SC, ST, LC	(2) AA, AC	OLS2-DUAL
◆	◆	◆		◆		2	LED and Laser	◆	FC, SC, ST, LC	(2) AA, AC	OLS4
		◆	◆	◆		1	Laser	◆	FC, SC, ST, LC	(2) AA, AC	OLS7-FTTH
		◆		◆	◆	1	Laser	◆	FC, SC, ST, LC	(2) AA, AC	OLS7-3

OLS Connector Adapters and AC Adapter

DESCRIPTION	AFL NO.
FC connector adapter	2900-50-0002MR
SC connector adapter	2900-50-0003MR
ST connector adapter	2900-50-0004MR
LC connector adapter	2900-50-0006MR
Universal flip-top dust cap for UCI outputs	8800-00-0072PR
100-240 VAC to 9 VDC, AC adapter	4050-00-0119PR

OLS Series Light Sources

Recommended Products



OFI-BIPM Optical Fiber Identifier

- World class signal sensitivity
- Trigger lock, positive stop for optimum detection
- Integrated optical power meter option



One-Click® Cleaners

- Patented single-action
- Variety of sizes and types
- Low cost per clean

Qualifications

CATEGORY	REGULATION/STANDARD	QUALIFICATION
CE Marking	EU	Compliant to relevant EU Directives on health, safety, and environmental protection, and certified with CE marking
Safety/EMC/EMI	IEC	Compliant to IEC 61010-1 for safety requirements for electrical equipment
	EN	Compliant to EN 61010-1 for safety requirements for electrical equipment
	IEC	Compliant to IEC 61326-1 for EMC requirements for electrical equipment
	EN	Compliant to EN 61326-1 for EMC requirements for electrical equipment
	EN	Compliant to EN 55011 for EMC requirements for industrial, scientific and medical equipment
	FDA	Compliant to code of federal regulations FDA 21 CFR 1040.10 and 1040.11 on laser products
	IEC	Compliant to IEC 60825-1 for safety of laser products
RoHS	EU	Compliant to EU regulations Directive 2011/65/EU (RoHS 2) and Directive 2015/863 (RoHS 3)
Test Method	TIA	Compliant to TIA-568.3-D for test and measurement requirements for premises optical fiber cabling and components*
	IEC	Compliant to IEC 11801 for test and measurement requirements for optical fiber cabling for use within premises*
	EN	Compliant to EN 50173 for test and measurement requirements for optical fiber cabling for use within premises*
	AS/NZS	Compliant to AS/NZS 3080 for test and measurement requirements for optical fiber cabling for use within premises*
	TIA	Compliant to TIA-526-7 for test procedures for installed optical fiber cable plant
	TIA	Compliant to TIA-526-14 for test procedures for installed optical fiber cable plant*
	IEC	Compliant to IEC 14763-3 for systems and methods for the inspection and testing of installed optical fiber cabling*
	AS/NZS	Compliant to AS/NZS 14763.3 for systems and methods for the inspection and testing of installed optical fiber cabling*
	IEC	Compliant to IEC 61280-4-1 for test procedures for installed optical fiber cable plant*
	IEC	Compliant to IEC 61280-4-2 for test procedures for installed optical fiber cable plant

* A complementary encircled flux mode conditioner may be needed to comply with encircled flux launch conditions for testing multimode optical fiber cabling and components

Contact Sales@AFLglobal.com to schedule a demonstration or learn how to buy.

Visit www.AFLglobal.com/Test to learn more about OLS series light sources.

International Sales and Service Contact Information available at www.AFLglobal.com/Test/Contacts

Contractor Series Light Sources and Power Meters

5 YEAR WARRANTY

Contractor Series Light Sources and Power Meters are rugged test instruments designed with a simple user interface and backed by an industry-leading 5-year warranty. Both single-mode and multimode kit options provide tools for measuring network insertion loss, continuity checks, and fiber identification.



CSS1-MM LED Source



CSS1-SM Laser Source



CSM1 Power Meter

Features

- Palm-sized rugged, dependable tools
- Industry-leading 5-year warranty
- Cost-effective, easy to use
- Auto-off to maximize battery life on Power Meter
- Large readable in bright or dim conditions

Applications

- Link loss measurements
- Certify SM and MM links to industry standards
- Continuity check and fiber identification prior to fusion splicing

CSM1 Power Meter

- Four models provide wide wavelength and power level ranges
- Stores optical references for each calibrated wavelength
- Auto-detects Test Tones for use in fiber identification
- Optical input port accepts a variety of thread-on adapter caps

CSS1-SM Laser Source

- 1310 nm and 1550 nm LASER output from single test port
- Output port accepts UCI threaded adapters (FC, SC, ST, LC) for flexibility and access to launch fiber for cleaning and inspection

CSS1-MM LED Source

- 850 nm and 1300 nm LED output from single test port
- 50 μ m and 62.5 μ m mandrels included
- **Test Tones** (2000, 1000, 330, 270 Hz) for fiber identification
 - Use power meters when technician has fiber end access

CSM1 Sources Transmit:

- **CW** continuous wave output (DC)
- **Test Tones** (2000, 1000, 330, 270 Hz) for fiber identification
 - Use power meters when technician has fiber end access
 - Use OFI (optical fiber identifier) for mid-span testing

Contractor Series Light Sources and Power Meters

Contractor Series Models

POWER METER MODELS	CALIBRATED WAVELENGTHS (nm)	TARGET APPLICATIONS
CSM1-3	850, 1300, 1310, 1490, 1550, 1625	Single-mode Measurements
CSM1-4	850, 980, 1310, 1490, 1550, 1625	High Power Single-mode Measurements

LIGHT SOURCES MODELS	FIBER TYPE	WAVELENGTHS (nm)	TARGET APPLICATIONS
CSS1-SM	SM	1310, 1550	SM Networks, LAN/WAN Testing
CSS1-MM	MM	850, 1300	Ethernet, Token Ring, and FDDI Fiber Links

LOSS TEST KITS MODELS	FIBER TYPE	POWER METER	LIGHT SOURCE	DYNAMIC RANGE (dB)
CKS-3	SM	CSM1-3	CSS1-SM	70 @ 1310/1550 nm, on 9/125 single-mode fiber
CKM-3	MM	CSM1-3	CSS1-MM	40 @ 850/1300 nm, on 62.5/125 multimode fiber
CKSM-2	SM	CSM1-3	CSS1-SM	60 @ 1310/1550 nm, on 9/125 single-mode fiber
	MM		CSS1-MM	40 @ 850/1300 nm, on 62.5/125 multimode fiber

Specifications ^a

OPTICAL SPECIFICATIONS: CSM1 POWER METER		
MODEL	CSM1-3	CSM1-4
Calibrated Wavelengths	850, 1300, 1310, 1490, 1550, 1625 nm	850, 980, 1310, 1490, 1550, 1625 nm
Detector Type	InGaAs	Filtered InGaAs
Measurement Range	+6 to -70 dBm	+26 to -50 dBm
Tone Detect Range	+6 to -50 dBm +6 to -45 dBm for 850 nm	+6 to -30 dBm +6 to -25 dBm for 850 nm
Accuracy ^b	±0.15dB (typical), ±0.3 dB	
Resolution	0.01 dB	
Measurement Units	dB, dBm, µW	

OPTICAL SPECIFICATIONS: CSM1 LIGHT SOURCE				
MODEL	CSS1-SM (Single Port)		CSS1-MM (Single-Port)	
Wavelength	1310 nm ±20 nm	1550 nm ±20 nm	850 nm ±20 nm	1300 nm +40/-60 nm
Spectral Width (max)	5 nm	5 nm	35 nm	170 nm
Emitter Type, Safety Class	Laser, Class I FDA 21 CFR 1040.10 & 1040.11, IEC 60825-1: 2007-03		LED, Class I FDA 21 CFR 1040.10 & 1040.11, IEC 60825-1: 2007-03	
Output Power	≥0.0 dBm into 9/125 fiber		≥-20.0 dBm into 62.5/125 fiber	
Output Stability ^c	±0.05 dB over 1 hour; ±0.15 dB over 8 hours		±0.1 dB over 1 hour; ±0.15 dB over 8 hours	
Tone Output	2000, 1000, 330, 270 Hz			

GENERAL SPECIFICATIONS			
MODEL	CSM1	CSS1-SM	CSS1-MM
Output Connector	Supports Most Industry Standard Connectors	SC, FC, ST, LC	SC Fixed
Power	2 AA batteries	2 AA batteries	2 AA batteries
Battery Life	>300 hours	75 hours (typical)	30 hours (typical)
Operating Temperature	-10 °C to 50 °C, 90 % RH (non-condensing)		
Storage Temperature	-30 °C to 60 °C, 90 % RH (non-condensing)		
Size (H x W x D)	14.0 x 8.1 x 3.8 cm (5.5 x 3.2 x 1.5 in) without boot		
Weight	0.29 kg (0.65 lb) without boot		

Notes:

- All specifications at 25 °C unless otherwise specified.
- Accuracy measured at 25 °C and -10 dBm per N.I.S.T. standards.
- After typical 30 second warm up.

Contractor Series Light Sources and Power Meters

Ordering Information

Each Contractor Series Kit ships with adapter caps for all included instruments, AA alkaline batteries, user guide, and carry case with room for optional cleaning supplies (see below). Fiber mandrels (50 micron and 62.5 micron) are included with CKSM-2 and CKM-2 kits.

When purchased separately, CSM1 power meters and CSS1 light sources ship with connector adapter, AA alkaline batteries, user guide, and carry case. Fiber mandrels (50 micron and 62.5 micron) are included with CSS1-MM units.

Test jumpers are required for operation (purchased separately). Test jumpers with a variety of connector styles and fiber types and adapter caps for most common connectors may be purchased from AFL.

Models and Configurations

MODEL NUMBER	INCLUDES
CKS-3-cc (cc = FC or SC)	Single-Mode Test Kit. Available with FC or SC connectors adapters.
CKM-3	Multimode Test Kit. Available with SC connector adapters.
CKSM-2	Single-mode and Multimode Test kit. Available with SC connector adapters.
CSS1-SM-cc (c = FC, SC, ST, or LC)	Single-mode LASER Source. Available with FC, SC, ST, or LC connector adapters.
CSS1-MM	Multimode LED Source. Available with SC connector adapter..
CSM1-3-cc (cc = *)	InGaAs Detector for single-mode applications.
CSM1-4-cc (cc = *)	High Power InGaAs Detector for single-mode applications.

* For CSM1 power meters, cc = FC, SC, ST, LC, 2.5 mm, 1.25 mm. Other connector styles are available; see accessories section.

CSS1-SM Single-mode Light Source Accessories

DESCRIPTION	AFL NO.
FC UCI connector adapter	2900-50-0002MR
SC UCI connector adapter	2900-50-0003MR
ST UCI connector adapter	2900-50-0004MR
LC UCI connector adapter	2900-50-0006MR
Universal flip-top dust cap for UCI outputs	8800-00-0072PR

CSM1 Power Meter Adapter Caps

DESCRIPTION	AFL NO.
2.5 mm Universal (accepts FC, SC, and ST ferrules)	8800-00-0214
1.25 mm Universal (accepts LC and MU ferrules)	8800-00-0224
FC	8800-00-0200
SC	8800-00-0209
ST	8800-00-0202
LC simplex	8800-00-0225
E-2000	8800-00-0221
2.5 mm open Universal, Accepts SC duplex, OptiTap connector	8800-00-0219
SMA	8800-00-0203
D4	8800-00-0201
Biconic	8800-00-0204

Contractor Series Light Sources and Power Meters

Recommended Products



OFI-BIPM Optical Fiber Identifier

- World class signal sensitivity
- Trigger lock, positive stop for optimum detection
- Integrated optical power meter option



One-Click® Cleaners

- Patented single-action
- Variety of sizes and types
- Low cost per clean

Qualifications

CATEGORY	REGULATION/STANDARD	QUALIFICATION
CE Marking	EU	Compliant to relevant EU Directives on health, safety, and environmental protection, and certified with CE marking
Safety/EMC/EMI	IEC	Compliant to IEC 61010-1 for safety requirements for electrical equipment
	EN	Compliant to EN 61010-1 for safety requirements for electrical equipment
	IEC	Compliant to IEC 61326-1 for EMC requirements for electrical equipment
	EN	Compliant to EN 61326-1 for EMC requirements for electrical equipment
	EN	Compliant to EN 55011 for EMC requirements for industrial, scientific and medical equipment
	FDA	Compliant to code of federal regulations FDA 21 CFR 1040.10 and 1040.11 on laser products
	IEC	Compliant to IEC 60825-1 for safety of laser products
RoHS	EU	Compliant to EU regulations Directive 2011/65/EU (RoHS 2) and Directive 2015/863 (RoHS 3)
Test Method	TIA	Compliant to TIA-568.3-D for test and measurement requirements for premises optical fiber cabling and components*
	IEC	Compliant to IEC 11801 for test and measurement requirements for optical fiber cabling for use within premises*
	EN	Compliant to EN 50173 for test and measurement requirements for optical fiber cabling for use within premises*
	AS/NZS	Compliant to AS/NZS 3080 for test and measurement requirements for optical fiber cabling for use within premises*
	TIA	Compliant to TIA-526-7 for test procedures for installed optical fiber cable plant
	TIA	Compliant to TIA-526-14 for test procedures for installed optical fiber cable plant*
	IEC	Compliant to IEC 14763-3 for systems and methods for the inspection and testing of installed optical fiber cabling*
	AS/NZS	Compliant to AS/NZS 14763.3 for systems and methods for the inspection and testing of installed optical fiber cabling*
	IEC	Compliant to IEC 61280-4-1 for test procedures for installed optical fiber cable plant*
	IEC	Compliant to IEC 61280-4-2 for test procedures for installed optical fiber cable plant
Generic Requirement	IEC	Compliant to IEC 61315 for requirements on calibration of fibre-optic power meters

* A complementary encircled flux mode conditioner may be needed to comply with encircled flux launch conditions for testing multimode optical fiber cabling and components.

Contact Sales@AFLglobal.com to schedule a demonstration or learn how to buy.

Visit www.AFLglobal.com/Test to learn more about Contractor Series Light sources and power meters.

International Sales and Service Contact Information available at www.AFLglobal.com/Test/Contacts

OPM5 and OPM4 Optical Power Meters

5 YEAR WARRANTY



OPM5 Optical Power Meter

Features

- Rugged, dependable, and backed by industry-best 5-year warranty
- Wave ID tests up to three wavelengths simultaneously - slashing test time
- Field-swappable connector adapters for maximum flexibility
- Long battery life from globally available AA batteries

Applications

- Passive Optical Networks (PON) testing
- OPM(5/4)-4D (Filtered-InGaAs) for high power (+26 dBm) CATV broadband networks or DWDM system applications
- OPM(5/4)-3D (InGaAs) for telecommunications networks
- OPM(5/4)-2D (Ge) for premises LAN/WAN multimode or single-mode networks
- OPM4-1D (Silicon) for multimode/plastic optical fiber applications

AFL is a trusted supplier of optical testing equipment with more than 30 years of experience and tens of thousands of units in use in the field. AFL's full range of power meters are used for testing single-mode and/or multimode fiber networks. Power meters with wave ID can detect two or more wavelengths simultaneously – decreasing test time and reducing user errors when paired with AFL wave ID light sources.

Designed for the real world: AFL's power meters are designed to meet the demands of the outside plant environment. They withstand the one-meter drop test and have splash resistant controls that are easy to use, even with gloves on.

Flexible and efficient: A range of field-swappable output adapters enables access for cleaning optical ports and supports multiple connector styles. The efficient design provides long test time from globally available AA batteries. Equipped with five-minute auto-off feature to save power.

Reduce test time and errors: Wave ID (Triple, Dual, or Single) decreases test time while reducing technician errors.

Stores test results: AFL's OPM5 stores optical reference at each calibrated wavelength. This enables technicians to organize test results into multiple files and transfer stored results via USB to the included PC-based TRM® 2.0 software for analyzing, generating reports, and printing. Users can generate network Pass/Fail results demonstrating compliance to industry standards and illustrate headroom. Fully N.I.S.T. traceable.

OPM5 and OPM4 Optical Power Meters

Specifications ^a

OPTICAL				
MODEL	OPM5-4D, OPM4-4D	OPM5-3D, OPM4-3D	OPM5-2D, OPM4-2D	OPM4-1D
Calibrated Wavelengths	850, 980, 1300, 1310, 1490, 1550, 1625 nm	850, 1300, 1310, 1490, 1550, 1625 nm	850, 1300, 1310, 1490, 1550 nm	650, 660, 850 nm
Detector Type	Filtered InGaAs	InGaAs	Germanium (Ge)	Silicon (Si)
Measurement Range	+26 to -50 dBm	+10 to -75 dBm	+6 to -60 dBm	+6 to -70 dBm
Tone Detect Range	+6 to -30 dBm +6 to -25 dBm for 850 nm	+10 to -50 dBm +10 to -45 dBm for 850 nm	+6 to -50 dBm +6 to -45 dBm for 850 nm	+6 to -45 dBm
Wavelength ID Range	+6 to -30 dBm +6 to -25 dBm for 850 nm	+10 to -50 dBm +10 to -45 dBm for 850 nm	+6 to -50 dBm +6 to -45 dBm for 850 nm	—
Accuracy ^b	±0.1 dB (typical); ±0.25 dB			
Resolution	0.01 dB			
Measurement Units	dB, dBm, µW			

GENERAL	
Power	2 x AA batteries, accepts standard mini-USB power adapter
Adapter Caps	Order with one: 1.25 mm Universal, 2.5 mm Universal, FC, SC, ST, LC. Other connector adapters available
Battery Life	300 hours
Operating Temperature	-10 °C to 50 °C, 95 % RH (non-condensing)
Storage Temperature	-30 °C to 60 °C, 95 % RH (non-condensing)
Size (H x W x D)	14.0 x 8.1 x 3.8 cm (5.5 x 3.2 x 1.5 in)
Weight	0.26 kg (0.58 lb)

Notes:

- a. All specifications valid at 25°C unless otherwise specified.
- b. Accuracy measured at 25 °C and -10 dBm per N.I.S.T. standards.

Ordering Information

All OPM models include optical power meter, 2 AA batteries, protective rubber boot, customer specified adapter cap, and carry case. OPM5 models also include TRM[®] 2.0 software (Basic License).

When placing an order, select options as follows:

- Model Number (M)
- Detector Type (N)
- Connector Configuration (CC)

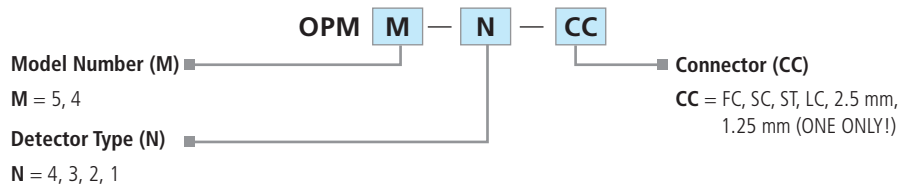

MODEL	CALIBRATED WAVELENGTHS (nm)									DETECTOR TYPE	MEASUREMENT RANGE (dBm)	PC SOFTWARE
	650	660	850	980	1300	1310	1490	1550	1625			
OPM5-4D			◆	◆		◆	◆	◆	◆	InGaAs	+26 to -50	TRM 2.0
OPM5-3D			◆		◆	◆	◆	◆	◆	InGaAs	+10 to -75	TRM 2.0
OPM5-2D			◆		◆	◆	◆	◆		Germanium	+6 to -60	TRM 2.0
OPM4-4D			◆	◆		◆	◆	◆	◆	InGaAs	+26 to -50	
OPM4-3D			◆		◆	◆	◆	◆	◆	InGaAs	+10 to -75	
OPM4-2D			◆		◆	◆	◆	◆		Germanium	+6 to -60	
OPM4-1D	◆	◆	◆							Silicon	+6 to -70	

OPM5 and OPM4 Optical Power Meters

OPM Accessories

DESCRIPTION	AFL NO.		
ADAPTER CAPS			
2.5 mm Universal (accepts FC, SC, and ST ferrules)	8800-00-0214		
1.25 mm Universal (accepts LC and MU ferrules)	8800-00-0224		
FC	8800-00-0200		
SC	8800-00-0209		
ST®	8800-00-0202		
LC simplex	8800-00-0225		
E-2000	8800-00-0221		
2.5 mm open Universal. Accepts SC duplex, OptiTap connector for measuring optical power.	8800-00-0219		
SMA	8800-00-0203		
D4	8800-00-0201		
Biconic	8800-00-0204		
USB CABLE			
USB Cable: PC (USB-A) to OPM (USB-MINI B): • Connect OPM to PC for data upload to TRM® 2.0 • External Power for OPM (when used with customer supplied USB-A power source)	OPM5 MODEL	OPM4 MODEL	6000-00-0024MR
	Connect to PC and External power	External power only	

Test Management and Reporting Software

DESCRIPTION	AFL NO.
TRM® 2.0 with Basic License (OTDR Trace/OLTS Viewer, Batch Editor and Reports), USB delivery	TRM-00-0900PR

OPM5 and OPM4 Optical Power Meters

Recommended Products



FlexScan® FS300 (quad) and FS200 (single-mode) OTDRs

- SmartAuto® 1-button automated testing for fast results
- LinkMap® color-coded icons for easy troubleshooting
- FleXpress® mode (FS200) completes OTDR test in <5 seconds!
- Integrated Source, Power Meter and VFL



Optical Light Sources

- Encircled Flux Compliant
- 5-Year Product Warranty
- Integrated LED and Laser light sources

Qualifications

CATEGORY	REGULATION/STANDARD	QUALIFICATION
CE Marking	EU	Compliant to relevant EU Directives on health, safety, and environmental protection, and certified with CE marking
Safety/EMC/EMI	IEC	Compliant to IEC 61010-1 for safety requirements for electrical equipment
	EN	Compliant to EN 61010-1 for safety requirements for electrical equipment
	IEC	Compliant to IEC 61326-1 for EMC requirements for electrical equipment
	EN	Compliant to EN 61326-1 for EMC requirements for electrical equipment
	EN	Compliant to EN 55011 for EMC requirements for industrial, scientific and medical equipment
RoHS	EU	Compliant to EU regulations Directive 2011/65/EU (RoHS 2) and Directive 2015/863 (RoHS 3)
Test Method	TIA	Compliant to TIA-568.3-D for test and measurement requirements for premises optical fiber cabling and components
	IEC	Compliant to IEC 11801 for test and measurement requirements for optical fiber cabling for use within premises
	EN	Compliant to EN 50173 for test and measurement requirements for optical fiber cabling for use within premises
	AS/NZS	Compliant to AS/NZS 3080 for test and measurement requirements for optical fiber cabling for use within premises
	TIA	Compliant to TIA-526-7 for test procedures for installed optical fiber cable plant
	TIA	Compliant to TIA-526-14 for test procedures for installed optical fiber cable plant
	IEC	Compliant to IEC 14763-3 for systems and methods for the inspection and testing of installed optical fiber cabling
	AS/NZS	Compliant to AS/NZS 14763.3 for systems and methods for the inspection and testing of installed optical fiber cabling
	IEC	Compliant to IEC 61280-4-1 for test procedures for installed optical fiber cable plant
	IEC	Compliant to IEC 61280-4-2 for test procedures for installed optical fiber cable plant
Generic Requirement	IEC	Compliant to IEC 61315 for requirements on calibration of fibre-optic power meters

Contact Sales@AFLglobal.com to schedule a demonstration or learn how to buy.

Visit www.AFLglobal.com/Test to learn more about OPM5 and OPM4 optical power meters.

International Sales and Service Contact Information available at www.AFLglobal.com/Test/Contacts

Mandrels

For use with 62.5 and 50 μm Multimode Test Jumpers with 3 mm Jackets



Features

- Allows existing 850/1300 nm LED light sources to test 50 and 62.5 μm links
- Attaches to 3 mm jumpers in seconds, without tools or tape
- May be reused indefinitely

Applications

- Required by TIA/EIA-568-B to measure attenuation on multimode fiber links
- Certification of multimode links for Gigabit and 10 Gigabit Ethernet

TIA/EIA-568-B specifies that attenuation (insertion loss) measurements of multimode fiber links, for all applications, must be made using an overfilled light source, such as an LED, with a mandrel-wrap mode filter on the transmit jumper. A key advantage of this specification is that it allows the use of existing overfilled LED light sources to certify both 50 and 62.5 μm fiber links for current and planned high bit rate applications including Gigabit Ethernet and 10 Gigabit Ethernet.

To meet the new multimode light source requirements in TIA/EIA-568-B, we offer mandrels for 50 and 62.5 μm test jumpers with 3 mm jackets. Both mandrels have grooves to ensure that jumpers are wrapped exactly five times (as specified by TIA/EIA-568-B) and can be easily attached to test jumpers in seconds without tools or tape.

Ordering Information

DESCRIPTION	AFL NO.
Kit with two mandrels: 62.5 and 50 μm fiber	5400-00-0900
Mandrel, 62.5 μm fiber	5400-00-0201
Mandrel, 50 μm fiber	5400-00-0202

Mandrels

For use with 62.5 and 50 μm Multimode Test Jumpers with 3 mm Jackets

Example Procedure

The following procedure illustrates how to make attenuation measurements of multimode fiber links using an LED light source, optical power meter, and mandrels. The procedure assumes that the link under test is terminated by ST connectors at both ends. However, it can easily be adapted for links terminated by other connector types simply by using the appropriate test jumpers and adapter caps. For this procedure you will need the following:

- (1) MM (LED) light source
- (1) optical power meter
- (1) ST adapter cap
- (1) 62.5 or 50 μm mandrel
- (2) test jumpers with 3 mm jackets and the same fiber type (62.5 or 50 μm) as the multimode link under test
- (1) ST-ST (mating) adapter

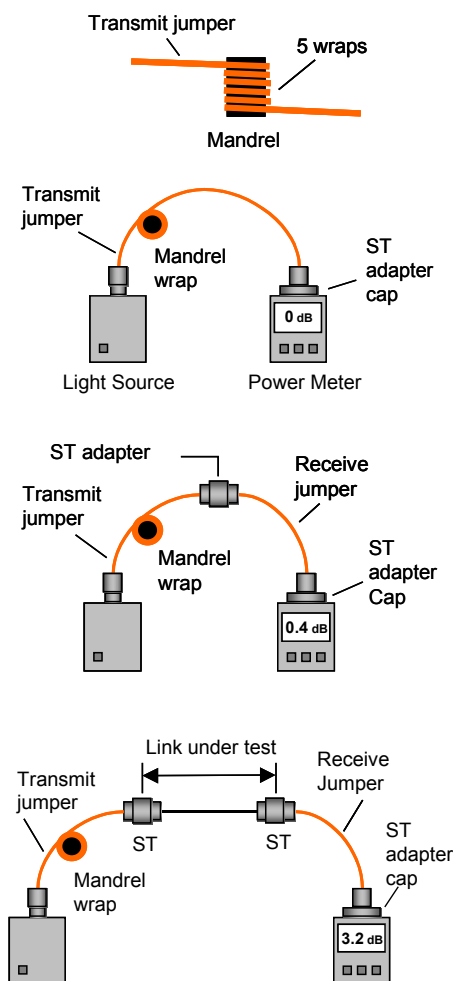

1 Attach Mandrel

Wrap the transmit jumper five times around the mandrel and attach it to the output port of the OLS 1 (LED source). Attach the ST adapter cap to the input port of the OPM 5 (optical power meter). Turn both units on and set wavelength to 850 nm.

2 Set Reference (One Jumper Method)

Connect the output of the OLS 1 directly to the input (ST adapter cap) of the OPM 5. Then press and hold the Set Ref (set reference) key until the word "HELD" appears. When you release the Set Ref key the OPM 5 should display "0 dB" (+/- 0.05 dB) indicating that the power measured at output of the transmit jumper has been recorded as the reference level for your insertion loss measurements.

3 Check Jumpers

Disconnect the transmit jumper from the OPM 5 (be sure NOT to remove the end of the jumper connected to the OLS 1). Attach the receive jumper to the OPM 5. Mate the free ends of the transmit and receive jumpers using the ST-ST adapter. Verify that the insertion loss of this mated connector pair is well under 0.75 dB, the maximum allowed by the TIA. Noyes recommends that the loss of your mated test jumpers be 0.4 dB. If not, clean both jumpers and repeat steps 2 and 3.

4 Test Links

Connect the OLS 1 and OPM 5 to opposite ends of the first link to be tested. Store the insertion loss measured by the OPM 5 by pressing the STORE key. You can repeat Step 4 to measure the insertion loss of each multimode link at 850 nm. Then, if required, set both units to 1300 nm and repeat Steps 2 thru 4 to measure the insertion loss of your multimode links at 1300 nm. The OPM 5 can store insertion loss results at 850 and 1300 nm for up to 500 fibers.

Contact Sales@AFLglobal.com to schedule a demonstration or learn how to buy.

Visit www.AFLglobal.com/Test to learn more about mandrels.

International Sales and Service Contact Information available at www.AFLglobal.com/Test/Contacts

MFIS Multi-Fiber Identification System



Features

- Identifies up to 12 fibers at a time
- Light-weight, rugged, and can be operated with one hand
- Optimized for use on 250 μm , 900 μm , and ribbon fiber
- Three-year calibration interval

Applications

- Multi-fiber network continuity assurance
- Fiber identification on both MFP power meter and MFI identifier
- Verify long-haul networks (up to 110 miles)
- Quickly verify FlexNap[®] network mapping

Multi-fiber network construction is time consuming, complicated, and often built by more than one contractor with mixed sets of documentation. There are guaranteed to be mislabeled and cross-connected fibers, which cost valuable time to find and fix. AFL's Multi-Fiber Identification System (MFIS) is a simple user-friendly way to verify network construction quickly and efficiently.

Rugged lightweight tools that can be operated with one hand: MFIS is a set of three tools that can be used to easily verify the fiber ID. The MFT (Multi-Fiber Trace) features 12 discrete laser sources (1550 nm single-mode) and an MTP fan-out connector. The digitally-coded light is then detected by either the MFI (Multi-Fiber Identifier), which clamps onto the fiber under test or the MFP (Multi-Fiber Power Meter), which plugs into the fiber under test.

Slash multiple fiber activations cost by up to 75% over conventional method: During service activation field technicians often run into unlabeled, mislabeled, and cross-connected fibers that can take two technicians hours to figure out - increasing cost and delaying service for customers. MFIS enables one technician to verify up to 12 fibers at a time, slashing the time it takes to activate new customers.

Ensure 100% multi-fiber network continuity: MFIS can be used to efficiently verify potentially cross-connected fibers at any point of an existing network – providing peace of mind to network managers.

MFIS Multi-Fiber Identification System

MFT Multi-Fiber Tracer Specifications^a

OPTICAL	
Wavelength	1550 ±20 nm
Spectral Width	5 nm (maximum)
Output Power	+1.75 dBm ±1 dB peak into 9/125 µm fiber @ +25 °C
GENERAL	
Power Supply	2 X 1.5 V AA alkaline batteries
Battery Life (Alkaline)	@ +25 °C: 40 hours (minimum); 50 hours (typical)
Connectors	SM: MTP/MPO-APC (unpinned) 12-fiber connector.
Size (without boot) W x L x H	96 x 145 x 35 mm (3.8 x 5.7 x 1.4 in)
Weight	307 g (0.676 lb) without boot; 458 g (1.01 lb) with boot
Operational Temperature	-20 °C to +50 °C 90 % RH (non-condensing)
Storage Temperature	-30 °C to +60 °C 90 % RH (non-condensing)

MFI Multi-Fiber Identifier Specifications^{a, b}

FIBER TYPE	PARAMETER	WAVELENGTH, SIGNAL	DETECTABLE SIGNAL RANGE
250 µm ribbon fiber, SMF28e+	Minimum data detect level (peak power, typical)	1550 nm, Data – Fiber ID	-35 dBm (typical)
	Insertion loss (typical/maximum)	1550 nm	2.5 dB/3.0 dB

OPTICAL	
Detector Type	InGaAs
Calibrated Fiber Size and Wavelength	250 µm @1550 nm (SMF-28/28E) ribbon fiber
Working Fiber Size	250 µm ribbon fiber
Data Detection Range	+2 to -35 dBm
GENERAL	
Display Type	Multi 7-segment LCD, 3 LEDs
Power Supply	2 X 1.5 V AAA, alkaline batteries
Battery Life (backlight off)	>10,000 operations ^c
Operation Temperature	-20 °C to +50 °C 90 % RH (non-condensing)
Storage Temperature	-30 °C to +60 °C 90 % RH (non-condensing)
Dimensions (H x W x D)	22 x 3.8 x 2.8 cm (8.5 x 1.5 x 1.1 in)
Weight	168 g (6 oz)

- Notes:**
- a. All specifications valid at 25 °C unless otherwise specified.
 - b. All specs are typical unless otherwise noted. Actual results can vary by several dB depending on fiber type, coating material, jacket color, jacket hardness, active fiber position, and other factors.
 - c. Operation is defined as turning unit on by taking 1 reading in a 10 second period.

MFIS Multi-Fiber Identification System

MFP Multi-Fiber Power Meter Specifications^a

OPTICAL	
Detector Type	InGaAs
Detector Size	1 mm
OPM Mode	
Calibrated Wavelength	850, 1300, 1310, 1490, 1550, 1625 nm
Measurement Range	+10 to -75 dBm
Accuracy ^b	±0.25 dB
Resolution	0.01 dB
Measurement Units	dB, dBm, µW
Fiber ID Mode ^e	
Wavelength	1550 nm
Measurement Range ^c	+10 to -35 dBm
Accuracy ^d	±0.5 dB
Resolution	0.01 dB
Measurement Units	dB, dBm, µW

Notes:

- a. All specifications valid at 25 °C unless otherwise specified.
- b. Accuracy measured at 25 °C and -10 dBm per N.I.S.T. standards.
- c. Measured using MFT (Multi-Fiber Tracer) as the light source.
- d. Accuracy measured at 25 °C with MFT (Multi-tiber Tracer).
- e. Subject to change.

Ordering Information

DESCRIPTION	AFL NO.
Multi-Fiber Identifier, no case	MF11-00-0900MR
Multi-Fiber Power Meter, no case	MFP1-12-0900MR
Multi-Fiber Tracer & Identifier with soft case	MFTI-12-BAS
Multi-Fiber Tracer & Power Meter with soft case	MFTP1-12-BAS
Multi-Fiber Tracer, Identifier, and Power Meter with soft case	MFTIP1-12-BAS
ACCESSORIES	
Cable, MPO/APC(M)-SC/APC, 12-fiber, SM, fan-out, 3 meters	8700-00-0198MR
Cable, MPO/APC (M) - SC/UPC, 12-fiber, SM, fan-out, 3 meters	8700-00-0200MR
Cable, MPO/APC (M) - LC/UPC, 12-fiber, SM, fan-out, 3 meters	8700-00-0201MR
One-Click Cleaner MPO (500+ cleans)	8500-05-0030MZ
One-Click Cleaner Mini-100 SC, ST, FC (100+ cleans)	8500-05-0005MZ

GENERAL	
Power	2 x AA batteries, accepts standard mini-USB power adapter
Adapter Caps	Order with one: 1.25 mm Universal, 2.5 mm Universal, FC, SC, ST, LC. Other connector adapters available
Battery Life	300 hours
Operating Temperature	-10 °C to 50 °C, 90 % RH (non-condensing)
Storage Temperature	-30 °C to 60 °C, 90 % RH (non-condensing)
Size (H x W x D)	14.0 x 8.1 x 3.8 cm (5.5 x 3.2 x 1.5 in)
Weight	0.26 kg (0.58 lb)

MFIS Multi-Fiber Identification System

Recommended Products



FOCIS Flex Connector Inspection

- Self-contained, tether-free, hand-held
- Auto-focus and auto-centering for fast, easy inspection
- IEC, IPC and user-defined pass/fail analysis



One-Click® Cleaners

- Patented single-action
- Variety of sizes and types
- Low cost per clean

Qualifications

CATEGORY	REGULATION/STANDARD	QUALIFICATION
CE Marking	EU	Compliant to relevant EU Directives on health, safety, and environmental protection, and certified with CE marking
Safety/EMC/EMI	IEC	Compliant to IEC 61010-1 for safety requirements for electrical equipment
	EN	Compliant to EN 61010-1 for safety requirements for electrical equipment
	IEC	Compliant to IEC 61326-1 for EMC requirements for electrical equipment
	EN	Compliant to EN 61326-1 for EMC requirements for electrical equipment
	EN	Compliant to EN 55011 for EMC requirements for industrial, scientific and medical equipment
	FDA	Compliant to code of federal regulations FDA 21 CFR 1040.10 and 1040.11 on laser products
	IEC	Compliant to IEC 60825-1 for safety of laser products
RoHS	EU	Compliant to EU regulations Directive 2011/65/EU (RoHS 2) and Directive 2015/863 (RoHS 3)
Generic Requirement	IEC	Compliant to IEC 61315 for requirements on calibration of fibre-optic power meters

Contact Sales@AFLglobal.com to schedule a demonstration or learn how to buy.

Visit www.AFLglobal.com/Test to learn more about OPM5 and OPM4 optical power meters.

International Sales and Service Contact Information available at www.AFLglobal.com/Test/Contacts.

OFI-BIPM and OFI-BIPMe Optical Fiber Identifiers



OFI-BIPM

OFI-BIPMe

Features

- World-class signal detection sensitivity
- Positive-stop trigger lock for optimum detection
- Integrated optical power meter
- 2.4" color touchscreen with backlight
- Up to 4 Tones detection (OFI-BIPMe only)

Applications

- Maintenance of fiber optic networks
- Troubleshooting network issues
- Identification of live fibers or trace fibers
- Power levels verification

The OFI-BIPM/-BIPMe optical fiber identifier is an easy-to-use tool that determines if a fiber is live, the transmission direction, and the relative core power on standard and bend-insensitive single-mode and multimode fibers. Its positive-stop trigger mechanism provides the right amount of pressure every time to assure proper detection, while keeping loss to a minimum. This ensures that traffic will not be interrupted and the fiber will not be damaged.

Nicknamed "The Job saver": The OFI-BIPM/-BIPMe removes the need to access the optical fiber at a connection or splice point, eliminating the possibility of interrupting service to a customer.

No heads to change or lose: The universal head of the OFI-BIPM/-BIPMe eliminates the need to change an adapter head for jacketed, coated, or ribbon fibers, making it extremely easy to use in the field.

Integrated optical power meter: The optical power meter mode verifies power levels during installation or troubleshooting.

Color touchscreen: The touchscreen provides simple-to-follow setup instructions and clear results that are easy to read.

Field technician favorite: The OFI-BIPM/-BIPMe is a favorite of technicians for its accuracy, ease of use, integrated power meter, and ergonomic design.

Doesn't damage delicate fibers: The positive-stop trigger ensures that the right pressure is applied every time, while the slim head makes it easier to reach and test tightly-packed fibers without damaging them.

OFI-BIPM and OFI-BIPMe Optical Fiber Identifiers

Specifications^a

OPTICAL (OFI)							
Fiber Type	0.25 mm SM and MM fiber; SM and MM ribbon fiber (up to 12 ribbon fiber) 1.1 mm/1.5 mm/1.7 mm/2.0 mm/3.0 mm SM and jacketed fiber						
Optical Characteristic	Wavelength Range	900 to 1700 nm					
	Detectable Light Signals	CW, Traffic or 270 Hz, 330 Hz (OFI-BIPMe only), 1 kHz, 2 kHz Tone ^b					
Insertion Loss (IL) & Minimum Detect Level ^c at Normal, Fast or Fine operation mode	Wavelength	1310 nm		1550 nm		1650 nm	
	Fiber Type	IL (dB)	Normal/Fast/Fine (dBm)	IL (dB)	Normal/Fast/Fine (dBm)	IL (dB)	Normal/Fast/Fine (dBm)
	0.25 mm (R=30 mm)	0.2	-58/-53/-64	1.0	-67/-62/-73	2.5	-67/-62/-73
	0.25 mm (R=15 mm), Ribbon	0.1	-44/-39/-50	0.3	-57/-52/-63	1.0	-57/-52/-63
	0.5 mm (R=15 mm)	0.2	-58/-53/-64	1.0	-67/-62/-73	2.5	-67/-62/-73
	1.1 mm/1.5 mm Jacketed	0.3	-43/-37/-53	1.0	-55/-50/-61	2.5	-57/-52/-63
	1.7 mm/2.0 mm Jacketed	0.5	-22/-17/-28	2.0	-27/-22/-33	3.0	-27/-22/-33
	3.0 mm Jacketed	1.0	-20/-15/-25	3.0	-23/-18/-28	3.0	-23/-18/-28

POWER METER (OPM)	
Wavelength	1310 nm, 1490 nm, 1550 nm
Detectable Light Signal	CW, Traffic or 270 Hz, 330 Hz (OFI-BIPMe only), 1 kHz, 2 kHz Tone ^b
Detector Sensitivity	+10 to -60 dBm at modulated tone; +10 to -40 dBm at CW or Traffic ^b
Accuracy ^d	±0.3 dB @1310/1550 nm; ±0.6 dB @1490 nm

GENERAL	
Operation Conditions	-10 to +50 °C, 0 to 95 % RH (non-condensing)
Storage Conditions	-20 to +60 °C, 0 to 95 % RH (non-condensing)
Power Supply	2 x AA batteries; 1.2 to 1.5 V DC
Battery Life	8 hours ^e
Dimensions (W x H x D)	5.0 x 11.5 x 21.2 cm (1.9 x 4.5 x 8.3 in) ^f
Weight	230 g (8.1 oz) including battery

Notes:

- a. All specifications valid at 25°C unless otherwise specified.
- b. Traffic is a light signal modulated by a random data sequence.
- c. Typical value. The minimum detect level (core power) the insertion loss varies due to coating material, color, etc.
- d. Under the condition of temperature 25°C with input power at -20 dBm.
- e. Using 2 Alkaline AA Batteries.
- f. Except protruding part.

OFI-BIPM and OFI-BIPMe Optical Fiber Identifiers

Ordering Information

DESCRIPTION	AFL NO.
BI Optical Fiber Identifier with integrated Optical Power Meter. The kit includes one 2.5 mm Universal Power Meter Port Adapter, BIPM-00-25.	OFI-BIPM
BI Enhanced Optical Fiber Identifier with integrated Optical Power Meter. The kit includes one 2.5 mm Universal Power Meter Port Adapter, BIPM-00-25.	OFI-BIPMe
OPTIONAL ADAPTERS (ordered separately)	
2.5 mm Universal Power Meter Port Adapter	BIPM-00-25
SC Power Meter Port Adapter	BIPM-00-SC
FC Power Meter Port Adapter	BIPM-00-FC
ST Power Meter Port Adapter	BIPM-00-ST
LC Power Meter Port Adapter	BIPM-00-LC

Recommended Products



FlexScan® FS300 (quad) and FS200 (single-mode) OTDRs

- SmartAuto® 1-button automated testing for fast results
- LinkMap® color-coded icons for easy troubleshooting
- FleXpress® mode (FS200) completes OTDR test in <5 seconds!
- Integrated Source, Power Meter and VFL



Optical Light Sources

- Encircled Flux Compliant
- 5-Year Product Warranty
- Integrated LED and Laser light sources

Qualifications

CATEGORY	REGULATION/STANDARD	QUALIFICATION
CE Marking	EU	Compliant to relevant EU Directives on health, safety, and environmental protection, and certified with CE marking
Safety /EMC /EMI	IEC	Compliant to IEC 61010-1 for safety requirements for electrical equipment
	EN	Compliant to EN 61010-1 for safety requirements for electrical equipment
	IEC	Compliant to IEC 61326-1 for EMC requirements for electrical equipment
	EN	Compliant to EN 61326-1 for EMC requirements for electrical equipment
	EN	Compliant to EN 55011 for EMC requirements for industrial, scientific and medical equipment
	FCC	Compliant to code of federal regulations FCC 47 CFR 15 on unlicensed transmissions
RoHS	EU	Compliant to EU regulations Directive 2011/65/EU (RoHS 2) and Directive 2015/863 (RoHS 3)

Contact Sales@AFLglobal.com to schedule a demonstration or learn how to buy.

Visit www.AFLglobal.com/Test to learn more about OFI-BIPM/-BIPMe.

International Sales and Service Contact Information available at www.AFLglobal.com/Test/Contacts

OFI-400 Series Optical Fiber Identifiers



OFI-400

OFI-400C

OFI-400HP

Features

- 5-year product warranty; 3-year recommended calibration interval
- Rugged, hand-held, lightweight, and easy-to-use
- Unique optical head with two-position plunger for use with all fiber types
- Built-in power meter with Set Reference feature

Applications

- Live fiber detection to avoid technician-induced outages
- Fiber identification and tracing with CW or tones
- Core power measurements
- Testing 250 μm , 900 μm , and ribbon fiber or 2 mm and 3 mm jacketed fiber

AFL's OFI-400 Optical Fiber Identifiers are rugged, hand-held, and easy-to-use fiber optic test instruments designed to detect and measure the core power levels of optical signals on single-mode optical fiber without disrupting traffic on that fiber. They are simply clamped onto a fiber and display the presence and direction of traffic, continuous test signals, and modulated test tones. This permits network personnel to easily and quickly identify a specific fiber without the risk of disrupting service. All of AFL's optical light sources are ideal companions to the OFI-400 family of optical fiber identifiers.

No adapters to purchase, store, swap, or misplace: Each OFI-400 uses a unique optical head design featuring a two-position plunger that enables it to be used with 250 μm , 900 μm , and ribbon fiber or 2 mm and 3 mm jacketed fiber. Other brands of optical fiber identifiers require users to purchase, store and change optical plungers each time a different type of fiber is tested.

Low insertion loss for in-service ID tasks: OFI-400's optical heads induces a safe, repeatable macro-bend to the fiber that allows a small amount of light to escape for analysis. The insertion loss induced by the macro-bend is too small to affect the signal on the fiber and the integrity of the fiber is unaffected by the measurement process.

Designed for the real world: The OFI-400 family are simple, easy-to-use tools that feature rugged, drop-proof construction - perfect for inside or outside plant use. Their ergonomically designed macro-bend trigger is comfortable to use and the integrated, backlit LCD display enables them to be used in dimly lit spaces. Each OFI-400 uses readily available 1.5 V AAA batteries which can power thousands of fiber tests before needing to be replaced.

OFI-400 model: The OFI-400 is designed for use with a wide range of single-mode fibers including 250 μm (bare) coated, 900 μm buffered and ribbon fibers or 2 mm and 3 mm jacketed fibers. The OFI-400 is ideal for network personnel involved in installation, reconfiguration, restoration and maintenance tasks that involve bare, buffered, jacketed or ribbon fibers in outside plant pedestals, fiber cabinets, aerial enclosures and inside plant premises demarcation cabinets. The slim design of the OFI-400 head facilitates access in crowded splice trays.

OFI-400C model: Designed specifically for use with 2 mm or 3 mm jacketed single-mode fibers, the OFI-400C is ideal for general purpose maintenance, configuration and installation tasks. The OFI-400C is functionally equivalent to the OFI-400 but includes an optical head design and a calibration scheme optimized for use with jacketed fiber.

OFI-400HP model: The OFI-400HP is designed for use where high levels of optical power are present. This includes fibers carrying a single high-power signal, CWDM or DWDM signals with high total power levels, amplified optical signals, or pump lasers associated with EDFA or Raman amplifiers. When display reaches +23 dBm (200 mW) or greater, the OFI-400HP will display "High" warning indication.

OFI-400 Series Optical Fiber Identifiers

Specifications^a

DETECTABLE SIGNAL RANGE					
FIBER TYPE ^b	PARAMETER	TEST CONDITIONS ^c	OFI-400	OFI-400C	OFI-400HP
250 µm coated fiber (SMF-28 with 250 µm CPC6 coating)	Minimum level detected, average power	1310 nm, CW, Tone, Traffic 1550 nm, CW, Tone, Traffic	-45 dBm -50 dBm	N/A	N/A
	Insertion loss (typical)	@ 1310 nm @ 1550 nm	0.6 dB 2.5 dB	N/A	N/A
3 mm jacketed fiber (SMF-28/28E with 250 µm CPC6 coating and 3 mm, yellow jacket)	Minimum level detected, average power	1310 nm, CW, Tone, Traffic 1550 nm, CW, Traffic 1550 nm, Tone	-30 dBm -33 dBm -33 dBm	-35 dBm -40 dBm -40 dBm	-30 dBm -40 dBm -35 dBm
	Insertion loss (typical)	@ 1310 nm @ 1550 nm	1.0 dB 2.8 dB	1.0 dB 2.8 dB	0.2 to 0.5 dB 0.8 to 1.3 dB

OPTICAL SPECIFICATIONS ^d	OFI-400	OFI-400C	OFI-400HP
Calibrated Fiber and Wavelength	250 µm @ 1550 nm (SMF-28/28E)	3 mm @ 1550 nm (SMF-28/28E)	
Working Fiber Size	250 µm, 900 µm, ribbon, 2 mm and 3 mm jacketed	2 mm and 3 mm jacketed	
Core Power Measurement Range ^e	+13 to -50 dBm @ 1550 nm, 250 µm	+13 to -40 dBm @ 1550nm, 3 mm	+33 to -40 dBm @ 1550 nm, 3 mm
Detector Type	InGaAs		
Wavelength Range	800 - 1700 nm		
Measurement Units	dBm, dB		
Fiber Stress	<100 kPSI max		
Tone Detection	270, 330, 1000, 2000 Hz (±5 %)		

GENERAL SPECIFICATIONS	ALL OFI-400 MODELS
User Interface	Multi 7 segment LCD; 3 LEDs; 1 piezo buzzer
Power	2 x 1.5 V AAA alkaline
Battery Life	>10,000 operations typical
Operation Temperature	-5°C to 50°C 95 % RH (Non-condensing)
Storage Temperature	-30°C to +60°C 95 % RH (Non-condensing)
Dimensions (H x W x D)	21.5 x 3.8 x 2.8 cm (8.5 x 1.5 x 1.1 in)
Weight	168 g (6 oz)

Notes:

- a. All specifications stated above are as measured at 25°C.
- b. 250 µm coated fiber parameters are specified with OFI plunger in the "250 / 900 / RIB" position. 2 mm / 3 mm jacketed fiber parameters are specified with OFI plunger in the "2 mm / 3 mm" position.
- c. CW is a light signal that is not modulated. Traffic is a light signal modulated by high speed user data. Tone is a light signal modulated into a nominal 50 % duty cycle square wave.
- d. Unless noted otherwise, all specifications are typical. Actual results can vary by several dB depending on fiber type, coating material, jacket color, jacket hardness, and other factors.
- e. SMF-28/28E.

OFI-400 Series Optical Fiber Identifiers

Ordering Information

All OFI-400 products include a user's guide, 2 AAA batteries and a soft carry case. Each carries a 5-year warranty and a 3-year recommended calibration interval.

INCLUDES	AFL NO.
Users guide, 2 AAA batteries, soft carry case	OFI-400
Users guide, 2 AAA batteries, soft carry case	OFI-400C
Users guide, 2 AAA batteries, soft carry case	OFI-400HP

Recommended Products



FlexScan® FS300 (quad) and FS200 (single-mode) OTDRs

- SmartAuto® 1-button automated testing for fast results
- LinkMap® color-coded icons for easy troubleshooting
- FleXpress® mode (FS200) completes OTDR test in <5 seconds!
- Integrated Source, Power Meter and VFL



Optical Light Sources

- Encircled Flux Compliant
- 5-Year Product Warranty
- Integrated LED and Laser light sources

Qualifications

CATEGORY	REGULATION/STANDARD	QUALIFICATION
CE Marking	EU	Compliant to relevant EU Directives on health, safety, and environmental protection, and certified with CE marking
Safety /EMC /EMI	IEC	Compliant to IEC 61010-1 for safety requirements for electrical equipment
	EN	Compliant to EN 61010-1 for safety requirements for electrical equipment
	IEC	Compliant to IEC 61326-1 for EMC requirements for electrical equipment
	EN	Compliant to EN 61326-1 for EMC requirements for electrical equipment
	EN	Compliant to EN 55011 for EMC requirements for industrial, scientific and medical equipment
RoHS	EU	Compliant to EU regulations Directive 2011/65/EU (RoHS 2) and Directive 2015/863 (RoHS 3)

Contact Sales@AFLglobal.com to schedule a demonstration or learn how to buy.

Visit www.AFLglobal.com/Test to learn more about Optical Fiber Identifiers.

International Sales and Service Contact Information available at www.AFLglobal.com/Test/Contacts

OFI-200 Optical Fiber Identifier



Features

- 5-year product warranty; 3-year recommended calibration interval
- Rugged, hand-held, lightweight, and easy-to-use
- Unique optical head with two-position plunger for use with all fiber types
- Visually and audibly indicates tone signal across 2 kHz range

Applications

- Live fiber identification to avoid technician-induced service outages
- Fiber tracing or identification with CW or test tones
- Testing 250 μm , 900 μm coated, 2 mm, 3 mm jacketed, and ribbon fiber

AFL Optical Fiber Identifiers are rugged, hand-held, and easy-to-use fiber optic test instruments designed to detect optical signals transmitted through a single-mode fiber without disrupting traffic.

The OFI-200 is simply clamped onto a fiber and indicates if there is NO SIGNAL, TONE, or TRAFFIC and the associated signal direction. This permits network personnel to easily and quickly identify a specific fiber without the risk of disrupting service. When testing coated fibers, the slim design of the OFI-200 allows easier access on a splice tray where the amount of workspace is limited.

No adapters to purchase, store, swap, or misplace: The OFI-200 uses a unique optical head design featuring a two-position plunger that enables it to be used with 250 μm , 900 μm , and ribbon fiber or 2 mm and 3 mm jacketed fiber. Other brands of optical fiber identifiers require users to purchase, store, and change optical plungers each time a different type of fiber is tested.

Low insertion loss for in-service ID tasks: The OFI-200 optical head induces a safe, repeatable macro-bend to the fiber that allows a small amount of light to escape for analysis. The insertion loss induced by the macro-bend is too small to affect the signal on the fiber and the integrity of the fiber is unaffected by the measurement process.

Designed for the real world: The OFI-200 is a simple, easy-to-use tool that features rugged, drop-proof construction perfect for inside or outside plant use. Its ergonomically designed macro-bend trigger is comfortable to use and the integrated, backlit LCD display enables it to be used in dimly lit spaces. The OFI-200 uses readily available 1.5 V AAA batteries, which power thousands of fiber tests before needing to be replaced.

OFI-200 Optical Fiber Identifier

Specifications ^a

DETECTABLE SIGNAL RANGE			
FIBER TYPE ^b	PARAMETER	TEST CONDITIONS ^c	OFI-200D
250 µm coated fiber (SMF-28 with 250 µm CPC6 coating)	Minimum level detected, average power	1310 nm, CW or Traffic 1310 nm, Tone 1550 nm, CW or Traffic 1550 nm, Tone	-40 dBm -43 dBm -45 dBm -50 dBm
	Insertion loss (typical)	1310 nm 1550 nm	0.6 dB 2.5 dB
3 mm jacketed fiber (SMF-28 with 250 µm CPC6 coating and 3 mm, yellow jacket)	Minimum level detected, average power	1310 nm, CW or Traffic 1310 nm, Tone 1550 nm, CW or Traffic 1550 nm, Tone	-30 dBm -32 dBm -33 dBm -37 dBm
	Insertion loss (typical)	1310 nm 1550 nm	0.8 dB 2.5 dB
OPTICAL SPECIFICATIONS ^d			
Detector Type	InGaAs		
Wavelength Range	800 - 1700 nm		
Calibrated Size of Fiber and Wavelength	N/A		
Fiber Stress	<100 kPSI max		
Fiber Size	250 µm, 900 µm, ribbon, 2 mm or 3 mm and jacketed fiber		
Tone Detection	2000 ± 100 Hz		
GENERAL SPECIFICATIONS			
Display Type	N/A		
Power	1 9-Volt Alkaline		
Battery Life	>10,000 operations typical		
Operation Temperature	0°C to 50°C 90 % RH (Non-condensing)		
Storage Temperature	-30°C to +60°C 90 % RH (Non-condensing)		
Dimensions (H x W x D)	22 x 3.8 x 2.8 cm (8.5 x 1.5 x 1.1 in)		
Weight	210 g (7.5 oz)		

Notes:

- All specifications stated above are as measured at 25°C.
- 250 µm coated fiber parameters are specified with OFI plunger in the "250/900/RIB" position. 2 mm/ 3 mm jacketed fiber parameters are specified with OFI plunger in the "2 mm/3 mm" position.
- CW is a light signal that is not modulated. Traffic is a light signal modulated by a random data sequence. Tone is a light signal modulated into a nominal 50% duty cycle square wave.
- Unless noted otherwise, all specifications are typical. Actual results can vary by several dB depending on fiber type, coating material, jacket color, jacket hardness, and other factors.

OFI-200 Optical Fiber Identifier

Ordering Information

INCLUDES	AFL NO.
Users guide and carry case	OFI-200D

Recommended Products



FlexScan® FS300 (quad) and FS200 (single-mode) OTRDs

- SmartAuto® 1-button automated testing for fast results
- LinkMap® color-coded icons for easy troubleshooting
- FleXpress® mode (FS200) completes OTDR test in <5 seconds!
- Integrated Source, Power Meter and VFL



Optical Light Sources

- Encircled Flux Compliant
- 5-Year Product Warranty
- Integrated LED and Laser light sources

Qualifications

CATEGORY	REGULATION/STANDARD	QUALIFICATION
CE Marking	EU	Compliant to relevant EU Directives on health, safety, and environmental protection, and certified with CE marking
Safety /EMC /EMI	IEC	Compliant to IEC 61010-1 for safety requirements for electrical equipment
	EN	Compliant to EN 61010-1 for safety requirements for electrical equipment
	IEC	Compliant to IEC 61326-1 for EMC requirements for electrical equipment
	EN	Compliant to EN 61326-1 for EMC requirements for electrical equipment
	EN	Compliant to EN 55011 for EMC requirements for industrial, scientific and medical equipment
RoHS	EU	Compliant to EU regulations Directive 2011/65/EU (RoHS 2) and Directive 2015/863 (RoHS 3)

Contact Sales@AFLglobal.com to schedule a demonstration or learn how to buy.

Visit www.AFLglobal.com/Test to learn more about Optical Fiber Identifiers.

International Sales and Service Contact Information available at www.AFLglobal.com/Test/Contacts

VFI4 Visual Fault Identifiers

Fiber Identification



VFI4 High Power Model

VFI4-L Low Power Model

Features

- Eye-safe Class 3R visible red laser source, 650 nm (High power version)
- Output power of 5.0 mW with 10 km range (High power version)
- Universal connector interface for quick connection
- 2.5 mm universal adapter (included) accepts FC, SC, ST, etc. connectors
- 1.25 mm universal adapter (included in High power version only) accepts LC and MU connectors
- Low power model - VFI4-L is available with output power of 1.0 mW with 4 km range

Applications

- Identify and trace fibers during activation and installation
- Identify poorly mated connectors
- Verify AFL's FASTConnect® field-installable connector installation
- Find faults inside OTDR dead zones

A Visible Fault Identifier (VFI), also referred to as a Visual Fault Locator (VFL), is an essential tool for fiber installation and maintenance technicians.

AFL's compact VFI4 injects high-powered red-laser light to provide exceptional brightness and range for locating defects in single-mode and multimode fibers. The light generated by these units will escape from sharp bends and breaks in jacketed or bare fibers, as well as poorly mated connectors enabling technicians to quickly spot faults. The universal connector interface mates with many connector styles without needing an adapter.

Rugged and Compact: The rugged VFI4 is designed for the rigors of real-life field testing. It has a range of up to 10 km, fits on a keychain, and features extensions that protect the red-laser port. It has both CW and pulsating modes and is powered by a single AA battery for up to 30 hours of operation.

Installation and Activation: VFI4 is used for quick continuity checks, fiber tracing, splice verification, and Pass/Fail validation for mechanical connectors. VFI4 is also an excellent complement to any OTDR because it can locate faults inside the OTDR's dead zone.

Essential Troubleshooting Tool: The VFI4 highlights sharp bends, breaks, faulty connectors, and other defects that "leak" light. Other applications include end-to-end continuity checks, as well as identifying connectors in patch panels and fibers during splicing operations.

VFI4 Visual Fault Identifiers

Specifications^a

OPTICAL	VFI4	VFI4-L
Emitter Type	Laser, Class IIIa FDA 21 CFR 1040.10 and 1040.11, Class 3R IEC 60825-1:2014	Laser, Class II FDA 21 CFR 1040.10 and 1040.11, Class 2 IEC 60825-1:2014
Wavelength	650 nm ±15 nm	
Output Power	5 mW maximum	1 mW maximum
Modulation	2 Hz or CW selected	

Notes:

a. All specifications valid at 25°C unless otherwise specified.

GENERAL	VFI4	VFI4-L
Adapter	2.5 mm Universal, 1.25 mm Universal	
Power	1 AA battery, <30 hours (flash mode)	1 AA battery, <50 hours (flash mode)
Operating Temperature	-10°C to 50°C, 85 % humidity non condensing	
Storage Temperature	-30°C to 60°C, 95 % humidity non condensing	
Size (H x W x D)	7.9 x 5.1 x 2.2 cm (3.1 x 2.0 x 0.9 in)	
Weight	43 g (1.5 oz)	

Ordering Information

DESCRIPTION	AFL NO.
VFI4 visual fault identifier with 2.5 mm and 1.25 mm adapters	VFI4-01-0900PR
VFI4-L visual fault identifier with 2.5 mm adapter	VFI4-02-0900PR

Adapters

DESCRIPTION	AFL NO.
2.5 mm Universal for VFI port	2900-50-0013MR
1.25 mm Universal for VFI port	2900-50-0012MR

Recommended Products



One-Click® Cleaner Mini

- Small compact design with single action cleaning
- Automatically advance ensures each clean is performed with fresh cleaning tape
- 100 clean and 500 clean versions available
- Low cost per clean



FASTConnect® Field-Installable Connectors

- Field-installable, takes less than a minute to complete
- Fast and easy to terminate
- Low insertion/return loss
- Reusable

Qualifications

CATEGORY	REGULATION/STANDARD	QUALIFICATION
CE Marking	EU	Compliant to relevant EU Directives on health, safety, and environmental protection, and certified with CE marking
Safety/EMC/EMI	IEC	Compliant to IEC 61010-1 for safety requirements for electrical equipment
	EN	Compliant to EN 61010-1 for safety requirements for electrical equipment
	IEC	Compliant to IEC 61326-1 for EMC requirements for electrical equipment
	EN	Compliant to EN 61326-1 for EMC requirements for electrical equipment
	EN	Compliant to EN 55011 for EMC requirements for industrial, scientific and medical equipment
	FDA	Compliant to code of federal regulations FDA 21 CFR 1040.10 and 1040.11 on laser products
RoHS	IEC	Compliant to IEC 60825-1 for safety of laser products
	EU	Compliant to EU regulations Directive 2011/65/EU (RoHS 2) and Directive 2015/863 (RoHS 3)

Contact Sales@AFLglobal.com to schedule a demonstration or learn how to buy.

Visit www.AFLglobal.com/Test to learn more about VFI4 Visual Fault Identifier.

International Sales and Service Contact Information available at www.AFLglobal.com/Test/Contacts.

MT Tracer

12-Fiber Visible Laser Source and Display



Features

- Viewing safe for eyes
- CW or 2Hz (2 cycles per second) output
- Direct connect - No fan-outs necessary

Applications

- Data Center - MPO Cable Verification
- Test polarity, continuity, and fiber mismatch
- Locate ends of unmarked cables in data centers

The MT Tracer is a compact multi-fiber visual fault locator (VFL) red laser source supporting 8- or 12-fiber MTP®/MPO connections. The user simply connects the 12-fiber cable directly to the unit and views the results.

Fibers can be tested individually or all at once. By progressing sequentially through the fibers, cables can be quickly checked for polarity by verifying the proper order at the output. Additionally, damaged fiber(s) are quickly identified with the MT Tracer saving trouble-shooting time when cables are put into service.

The MT Tracer source can be used to quickly trace cables in messy or un-documented setups. It provides a foolproof way of finding the “other end” amongst cluttered or unlabeled cables. Simply connect the MT Tracer Source to one end and look for the visual red light transmitted out the opposite connector.

The MT Tracer kit from AFL is a complete MTP/MPO cable polarity and continuity test solution and a must-have for technicians working with high-density fibers.

MT Tracer

12-Fiber Visible Laser Source and Display

Specifications

MT TRACER SOURCE	
Optical Wavelength	650 ±40 nm
Output Power Level	Minimum 0.5 mW, typical 1.0 mW (at each SM 9/125 fiber at the end of MTP cord)
Optical Connector	MTP® male SM, angled
Number of Output Fibers	12
Power	2 x AA alkaline batteries
Battery Life (alkaline)	40 hours
Low Battery	Indicated by 2 Hz LED blinking
Weight	0.29 kg (0.63 lb)
MT TRACER DISPLAY	
Input Connector	MTP® angled male 62.5 μ fiber
No. of input Connectors	1 (12-fiber MTP)
GENERAL	
Weight	Source: 0.29 kg (0.63 lb); Display 0.18 kg (0.4 lb)
Dimensions	9.9 x 3.8 x 14.3 cm (3.9 x 1.5 x 5.6 in)
Operation Temperature	0 °C to 40 °C, RH 85 % non-condensing
Storage Temperature	-30 °C to 50 °C, RH 95 % non-condensing

Ordering Information

DESCRIPTION	AFL NO.
MT Tracer Kit: Includes MT Tracer Source, MT Tracer Display, and carry case	TRCR-90-0900
MT Tracer Source	TRCR-20-0900
MT Tracer Display	TRCR-10-0900

Qualifications

CATEGORY	REGULATION/STANDARD	QUALIFICATION
CE Marking	EU	Compliant to relevant EU Directives on health, safety, and environmental protection, and certified with CE marking
Safety	EN	Compliant to EN 61010-1 for safety requirements for electrical equipment
	EN	Compliant to EN 61326-1 for EMC requirements for electrical equipment
RoHS	EU	Compliant to EU regulations Directive 2011/65/EU (RoHS 2) and Directive 2015/863 (RoHS 3)

Contact Sales@AFLglobal.com to schedule a demonstration or learn how to buy.

Visit www.AFLglobal.com/Test to learn more about MT Tracer

International Sales and Service Contact Information available at www.AFLglobal.com/Test/Contacts

aeRos® Cloud-based Test Management and Reporting



Features

- Cloud-based
- Real-time, on-site test data validation and progress tracking
- Automatic sync of test configurations and results
- Centralized test management

Applications

- Efficient Workflow Management
- Seamless testing using a variety of smart devices
- Customizable reporting and analysis

aeRos, AFL’s cloud solution, combines AFL’s ROGUE OLTS Certification Products and FOCIS Flex Fiber Optic Inspection products with a cloud-based workflow management system that enables seamless and efficient communications and data management.

Cloud-based, comprehensive workflow management solution: Every aspect of the testing process is more efficient. No matter where you are or what technology you use, coordinating with your field technicians is simpler and more cost-effective than ever.

Centralized test management and reporting: Now you can set-up jobs from anywhere and push them to your testers. Because you’re monitoring jobs and communication in real time, you can dramatically reduce field errors and expensive re-testing. The aeRos easy-to-use reporting template includes “what if” analysis against different industry standards.

Test data and project updates auto-sync with the cloud: With aeRos you can make changes to your workflow on the fly and never worry about losing data. With no waiting for equipment to come back for download, you’ll get to reports and revenue sooner.

Track test progress and validate test results on all active jobs: With aeRos, you can see passed/failed links in real time and plan troubleshooting more efficiently. You’ll always know if your projects are on track.

aeRos solution is available in two options: aeRos BASIC account and aeRos PRO account.

aeRos® BASIC account — Data Management solution that allows users to save their test data in the aeRos Cloud and then retrieve it from anywhere at any time with a standard Internet browser. aeRos BASIC is free to all owners of AFL’s ROGUE modular test equipment.

aeRos® PRO account — Workflow Management solution that allows users to manage their entire testing workflow and enables seamless and efficient communications and data management. aeRos PRO is available in annual and lifetime License configurations.

aeRos Software Licensing

DESCRIPTION	AFL NO.
aeRos PRO (1) account, 1 year subscription	aeRos-PRO-YRL
aeRos PRO (1) account, lifetime subscription	aeRos-PRO-LFT

Contact Sales@AFLglobal.com to schedule a demonstration or learn how to buy.

Visit www.AFLglobal.com/Test to learn more about aeRos® Cloud-based Test Management and Reporting Software.

International Sales and Service Contact Information available at www.AFLglobal.com/Test/Contacts

TRM® 2.0/3.0 Test Results Manager

Comprehensive Analysis and Reporting Software

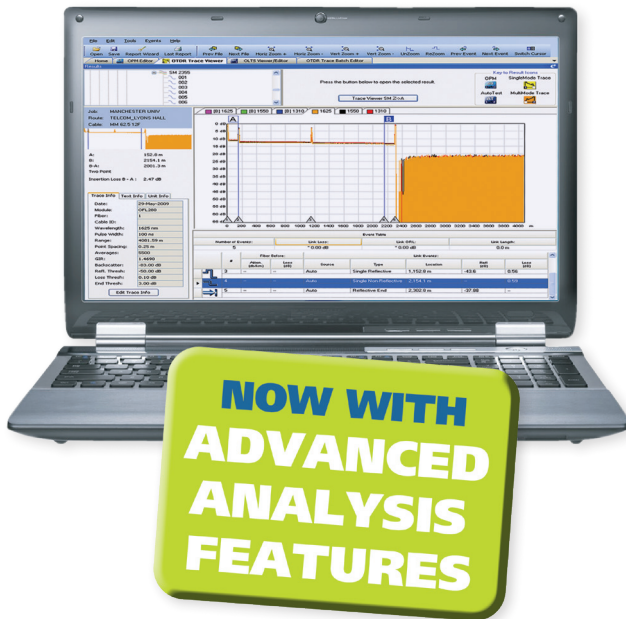

TRM Basic

- Generates acceptance reports
- Creates certification results and applies Pass/Fail
- Documents networks
- OTDR batch editing
- Telcordia (GR-196 v1.1, SR-4731 issue 1 & 2) .SOR file formats

TRM Advanced Adds

- Macro/Microbend detection
- Automatic bi-directional trace analysis
- Create reports with macrobend and bi-directional trace averaging
- Exporting .SOR file to .CSV file format

TRM Test Results Manager is PC-based software that provides comprehensive test results analysis and reporting for AFL test and inspection products. TRM Basic software enables users to quickly view loss or certification results, batch-edit OTDR traces, and create acceptance reports conforming to industry guidelines. TRM Basic can generate reports showing dual wavelength traces and event tables, end-face image, event map and loss data for each fiber. Users can apply pass/fail thresholds to OTDR events and OLTS measurements, and create and apply application rules per industry standards. TRM’s OTDR Batch Editor enables users to edit and analyze multiple trace files simultaneously.

Advanced upgrade expands analysis & reporting functions: TRM Advanced includes all TRM Basic’s functionality and adds macro/microbend detection, automatic bi-directional trace averaging, and .SOR file export to .CSV file format.

Include Inspection Images in Reports: TRM Basic and TRM Advanced software allow integration of fiber inspection images from the FOCIS family inspection products to be included in customized test reports. Both versions support Bellcore/Telcordia .SOR file formats.

Wireless transfer of data: TRM 3.0 Basic supports downloading the FlexScan family of OTDRs test results from the cloud using the free FlexScan App available from the Google play for Android mobile devices.

User friendly interface makes reviewing results easy: OTDR, certification, inspection, and OPM test results are indicated by specific icons to simplify selection of test results to review.

Industry Standard and User-defined Reports: Test to Industry Standards (ISO/TIA/EN), Application Rules (IEEE/ ANSI), or create User Rules and User Application Rules. As new rules and applications develop, compare existing test results to the new rules, such as emerging Ethernet standards. Supports industry-standard 10GbE IEEE 802.3ae specification using pre-configured 10GbE application rules. Produces detailed 10GbE test report.

Report Flexibility and Customization: A Report Wizard enables users to generate personalized reports for customer’s job acceptance. Generated reports meet accepted industry documentation and feature customized cover pages with customer’s logos. Can create dedicated inspection, insertion loss and OTDR reports, as well as reports combining OTDR, power meter and inspection results.

TRM® 2.0/3.0 Test Results Manager

Difference between TRM 2.0 and TRM 3.0

- TRM 2.0 Software supports AFL M-series and FlexTester OTDRs and OPM5 Power Meter
- TRM 3.0 Software supports AFL FlexScan (FS200 and FS300) OTDRs, ROGUE OLTS Certifier, and FOCIS family connector inspection probes.

Basic and Advanced Software Comparison

FEATURES	BASIC SOFTWARE	ADVANCED SOFTWARE
OTDR Trace/OLTS Viewer	◆	◆
OTDR Trace Batch Editor	◆	◆
Pre-defined Template for Reports	◆	◆
FOCIS Flex Inspection Images and Pass/Fail Table; FOCIS WiFi and DFS1 Inspection Images	◆	◆
Telcordia (GR-196 v1.1, SR-4731 issue 1 & 2) .SOR file formats	◆	◆
Macrobend/Microbend; Report with Macrobend/Microbend Events		◆
Automatic Bi-directional OTDR Event Table; Report with Bi-directional OTDR Trace/Event information		◆
Export .SOR File Contents to .CSV File		◆
License Key	Required (Seat License)	

Ordering Information

TRM Basic software is included with FlexScan OTDRs, ROGUE OLTS Certifier, FOCIS family connector inspection probes, and OPM5 power meters (may be installed in up to 5 PCs). Users may download a full working version of TRM (Basic plus Advanced features) and try it for 30 days. Once the evaluation period ends, users must purchase and install a TRM Basic or Advanced software license to continue to use TRM.

TRM 2.0 Ordering (for use with M-series and FlexTester OTDRs and OPM5 Power Meter)

DESCRIPTION		AFL NO.
Basic License (OTDR Trace/OLTS Viewer, Batch Editor and Reports)	USB delivery	TRM-00-0900PR
	email delivery	TRM-01-0900PR
Advanced License (Basic plus Advanced Analysis)	USB delivery	TRM-00-0910PR
	email delivery	TRM-01-0910PR
Upgrade from Basic to Advanced License	USB delivery	TRM-00-0920PR
	email delivery	TRM-01-0920PR

TRM 3.0 Ordering (for use with FlexScan OTDRs, ROGUE OLTS Certifier, and FOCIS family products)

DESCRIPTION		AFL NO.
Basic License (OTDR Trace/OLTS Viewer, Batch Editor and Reports)	USB delivery	TRM3-BASIC
	email delivery	TRM3-BA-EMAIL
Advanced License (Basic plus Advanced Analysis)	USB delivery	TRM3-ADVANCED
	email delivery	TRM3-AD-EMAIL
Upgrade from Basic to Advanced License	USB delivery	TRM3-UPGRADE
	email delivery	TRM3-UP-EMAIL
FlexScan App for wireless results transfer with TRM (Android Google play)		Free Download

TRM Supported Languages

- English
- Polish
- Turkish
- French
- Portuguese
- Chinese
- German
- Russian
- Japanese
- Italian
- Spanish

TRM® 2.0/3.0 Test Results Manager

Powerful Batch Processing

Analysis

- Edit cables or groups of fibers in one batch session
- Modify event pass/fail thresholds: Loss, ORL, Link Loss, Link ORL
- Add, remove, or adjust Launch and Receive cables
- Adjust the location of the cursors

Documentation

Add and/or edit

- Trace File Names (Fiber Number, Cable ID, End 1, End 2, and Direction of test)
- Cable Information (Cable Type and GIR)
- Job Information (Company, Main Operator, Second Operator, and Comment)

Reporting

- Generate professional reports by applying edits to a group of fibers for consistency of information and uniformity of results

Create Professional Personalized Reports

Featuring the Report Wizard - a powerful tool for creating test reports, TRM allows users to generate personalized professional reports for customer's job acceptance.

Generated reports meet accepted industry documentation and can be personalized by customizing cover pages to include customer's logos.

Create dedicated inspection, insertion loss and OTDR reports, as well as reports combining OTDR, power meter and inspection results.

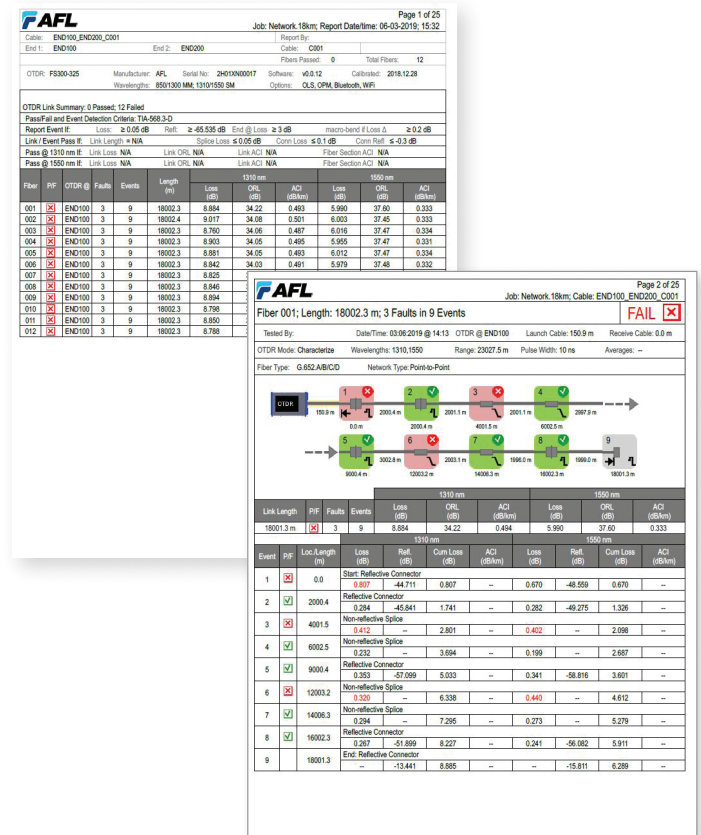
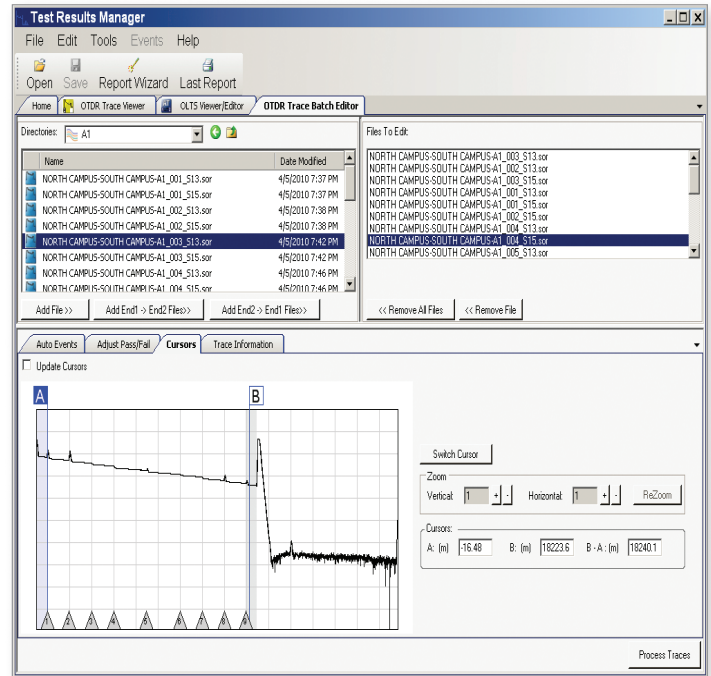

TRM® 2.0/3.0 Test Results Manager

Report Examples

OTDR Cable Summary Page

OTDR cable summary page shows job information and test setup, Loss and ORL test results with or without thumbnails of OTDR traces (shown with Loss/ORL table and OTDR thumbnails).

Cable ID : MM 62.5 12F Tested By : SUZY OTR Setup : Export
 End 1 : TELCOM Launch Cable : Noyes (150m) End Thres : 3 dB
 End 2 : LYONS HALL Tail Cable : Noyes (150m) Loss Thres : 0.1 dB
 Date Of Test : 07/27/2009 16:06:16 GR : 1.688 Refl Thres : -45 dB
 Backscatter Coef : -68 dB

OTDR Summary
 Length 589.1 Meters

Fiber #	Loss(dB) End 1 → End 2		Loss(dB) End 2 → End 1		ORL(dB) End 1 → End 2		ORL(dB) End 2 → End 1	
	850nm	1300nm	850nm	1300nm	850nm	1300nm	850nm	1300nm
1	1.95	0.57	1.90	0.54	-26.12	-32.01	-26.00	-32.04
2	1.95	0.57	1.92	0.54	-26.04	-32.01	-26.17	-32.00
3	1.99	0.57	1.90	0.55	-26.08	-32.00	-26.10	-32.03
4	2.00	0.58	1.95	0.54	-26.12	-32.06	-26.05	-32.00
5	1.98	0.57	1.91	0.53	-26.16	-32.06	-26.01	-32.00
6	1.95	0.59	1.91	0.53	-26.08	-32.08	-26.10	-32.00

Fiber Detail Results Page

Fiber Detail Results page documents equipment used for testing, job information, test setup, cursor info and OTDR trace with Event map. OPM or Certification results and end-face image and pass/fail results may be included if available (as shown) with an overall Pass or Fail.

Certification Report Page

Certification report page shows:

- 1 - Overall Pass/Fail report to standards (ISO shown)
- 2 - Pass/Fail indicated for each fiber
- 3 - User Rule and Applications for which the fibers have passed.

Certification Results Cabling Standard : ISO 11801 (International Standard) all cables, 50 or 62.5 µm fiber. 1

Number of Connections : 2 Loss Limit : 850nm (3.58 dB), 1300nm (2.39 dB)
 Number of Splices : 0 Length Limit : 2000 Meters

TELCOM-LYONS HALL-MM 62.5 12F.atd

Date of Test	Time	Fiber #	Loss (dB)		Length (m)	PIF	Headroom (dB)		
			850 nm	1300 nm			850 nm	1300 nm	
Jul 27, 2009	3:35 PM	1	E1→E2	2.95	1.65	594.63	Pass	0.63	0.74
			E2→E1	2.68	1.42			0.90	0.97
Jul 27, 2009	3:36 PM	2	E1→E2	2.72	1.84	594.83	Pass	0.86	0.55
			E2→E1	2.91	1.69			0.67	0.70
Jul 27, 2009	3:36 PM	3	E1→E2	2.53	1.60	594.12	Pass	1.05	0.79
			E2→E1	2.88	1.42			0.90	0.97
Jul 27, 2009	3:37 PM	4	E1→E2	2.72	1.85	594.12	Pass	0.88	0.54
			E2→E1	2.91	1.69			0.67	0.70
Jul 27, 2009	3:38 PM	5	E1→E2	2.55	1.83	594.37	Pass	1.03	0.76
			E2→E1	2.86	1.42			0.90	0.97
Jul 27, 2009	3:39 PM	6	E1→E2	2.72	1.89	594.37	Pass	0.88	0.55
			E2→E1	2.91	1.69			0.67	0.70

Applications these fibers have been tested to support : User Defined Rule (Marriot Rule) 10/100BASE-SX (850 nm) on (OM1) 62.5 µm fiber. 3

Contact Sales@AFLglobal.com to schedule a demonstration or learn how to buy.

Visit www.AFLglobal.com/Test to learn more about TRM.

International Sales and Service Contact Information available at www.AFLglobal.com/Test/Contacts

Please contact your AFL Sales Representative for information about our other products or services.

**FIBER OPTIC CABLE
(OPGW, ADSS, Loose Tube)**



**FIBER OUTSIDE PLANT
EQUIPMENT**



**FUSION SPLICING
SYSTEMS AND ACCESSORIES**



**FIELD-INSTALLABLE
CONNECTORS**

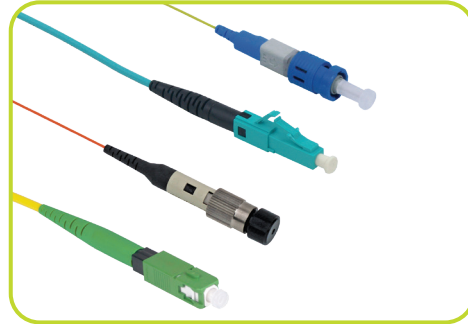

International Sales and Service Contact Information

Available at www.AFLglobal.com/Test/Contacts

