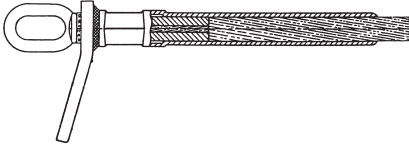

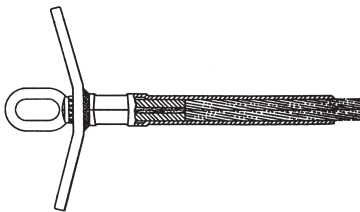
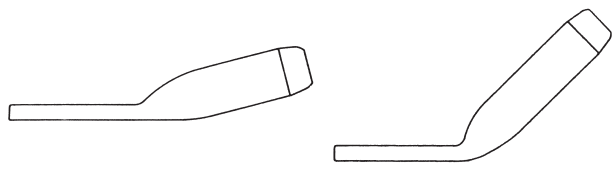

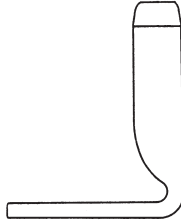

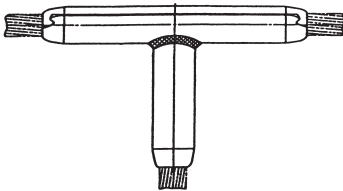

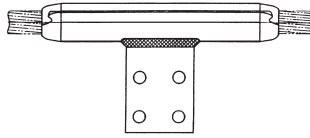

Table of Contents

Quick Compress Pictorial Index	150	Adjustable Clevis Dead End – ACS Series	229
Quick Compress Accessories Overview	151	Adjustable Eye Dead End – AES Series	231
<i>Quick Reference Guide</i>			
ACSR Conductor Quick Reference Guide	152	Compression Joint – CJ Series	233
AAC Conductor Quick Reference Guide	154	Replacement Compression Joint – CJR Series	235
AAAC and ACAR Conductor Quick Reference Guide	155	Repair Sleeve – RS Series	237
Quick Compress Catalog Numbering System	156	Jumper Connector – JC Series	239
<i>ACSR Accessories</i>			
Single Tongue Dead End – VES/HES Series	159	Straight Terminal Connector – TS Series	241
Double Tongue Dead End – VED/HED Series	162	15° Terminal Connector – TF Series	243
Adjustable Clevis Dead End – ACS Series	165	45° Terminal Connector – T45 Series	245
Adjustable Eye Dead End – AES Series	168	90° Terminal Connector – TN Series	247
Compression Joint – CJ Series	171	Open Run Tee Connector – TTOC Series	249
Replacement Compression Joint – CJR Series	173	Open Run Tee Tap – TTOP Series	250
Repair Sleeve – RS Series	175	<i>Ground Wire Accessories</i>	
Jumper Connector – JC Series	177	Single Tongue Dead End – GWDE Series	253
Straight Terminal Connector – TS Series	179	Compression Joint – GWJ Series	256
15° Terminal Connector – TF Series	182	<i>Quick Compress® Reference Material</i>	
45° Terminal Connector – T45 Series	185	NEMA Standard Pad Sizes	257
90° Terminal Connector – TN Series	188	Steel Eye Dimensions	257
Open Run Tee Connector – TTOC Series	191	Bolt Sizes and Recommended Torque	257
Open Run Tee Tap – TTOP Series	193	Adjustable Steel Clevis Dimensions	258
<i>AAC Accessories</i>			
Single Tongue Dead End – VESE/HESE Series	197	Adjustable Steel Eye Dimensions	258
Double Tongue Dead End – VEDE/HEDE Series	199	Conductor Information for ACSR Conductors	259
Adjustable Clevis Dead End – ACSE Series	201	Conductor Information for AAC Conductors	261
Adjustable Eye Dead End – AESE Series	203	Conductor Information for AAAC Conductors	263
Compression Joint – CJE Series	205	Conductor Information for ACAR Conductors	264
Replacement Compression Joint – CJER Series	207	<i>Quick Compress® Installation Instructions</i>	
Repair Sleeve – RS Series	209	Dead Ends – ACSR	265
Jumper Connector – JC Series	211	Dead Ends – Adjustable AAC, AAAC and ACAR	266
Straight Terminal Connector – TS Series	213	Dead Ends – ACSR, AAC, AAAC and ACAR	266
15° Terminal Connector – TF Series	215	Dead Ends – Alumoweld® and Steel Ground Wire	267
45° Terminal Connector – T45 Series	217	Compression Joints – AAC, AAAC, ACAR, Alumoweld® and Steel Ground Wire	268
90° Terminal Connector – TN Series	219	Compression Joints – ACSR	269
Open Run Tee Connector – TTOC Series	221	Repair Sleeves – ACSR, AAC, AAAC and ACAR	270
Open Run Tee Tap – TTOP Series	223	Jumper Connectors – ACSR, AAC, AAAC, ACAR, Alumoweld® and Steel Ground Wire	271
<i>AAAC and ACAR Accessories</i>			
Single Tongue Dead End – VES/HES Series	225	Terminal Connectors	272
Double Tongue Dead End – VED/HED Series	227	Open Run Tee Taps – ACSR, AAC, AAAC and ACAR	274
		Open Run Tee Connectors – ACSR, AAC, AAAC and ACAR	274
		Quick Compress® Index	275

Pictorial Index

QuickCompress®

QUICK COMPRESS®	
<p>Dead End – Single Tongue Eye: pgs. 159, 168, 197, 203, 225, 231, 253 Clevis: pgs. 165, 201, 229</p> 	<p>Straight Terminal Connector pgs. 179, 213, 241</p> 
<p>Dead End – Double Tongue pgs. 162, 199, 227</p> 	<p>Angled Terminal Connector 15° pgs. 182, 215, 243 45° pgs. 185, 217, 245</p> 
<p>Compression Joint pgs. 171, 173, 205, 207, 233, 235, 256</p> 	<p>90° Terminal Connector pgs. 188, 219, 247</p> 
<p>Repair Sleeve pgs. 175, 209, 237</p> 	<p>Open Run Tee Connector pgs. 191, 221, 249</p> 
<p>Jumper Connector pgs. 177, 211, 239</p> 	<p>Open Run Tee Tap pgs. 193, 223, 250</p> 

Quick Compress Accessories for Maximum Conductor Operating Temperatures of 100°C (212°F)



In the past, three separate compression accessory series were required to connect ACSR, AAC, AAAC and ACAR. To assist utilities and distributors in reducing inventory, AFL designed one series of compression accessories that can handle all four conductor types, the Quick Compress Product Line. Quick Compress handles these conductors while maintaining the same mechanical and electrical reliability as other AFL product lines.

There are two primary characteristics that make Quick Compress different from any other accessory line. First, it is made of a high strength aluminum alloy, which has a minimum tensile strength nearly twice that of other compression accessory systems. This means that for the same conductor size, smaller connectors can be used without any fear of sacrificing strength. Secondly, Quick Compress uses an aluminum 'core grip' to hold the steel core of ACSR. This eliminates the need to have a dead end steel compression barrel or a steel sleeve for full tension ACSR joints. By eliminating the steel, only one set of dies is required for installing Quick Compress Accessories.

All compression accessories are designed to operate at a temperature 15% to 25% cooler than the conductor. Quick Compress accessories are designed for a maximum conductor operating temperature of 100°C (212°F). For applications exceeding 100°C (212°F) operating temperature, see the Standard and HiTemp® Compression Accessories sections.

Features

Installs in 40% Less Time

Quick Compress Accessories are designed to save valuable time. They are made of a high strength alloy allowing for shorter accessories resulting in fewer compression bites. The accessories come pre-filled, the steel eye is pre-compressed and a one-piece core grip is included. Compared to other two-die accessory systems, Quick Compress Accessories can be installed in 40% less time.

One-Piece Core Grip

When using ACSR conductor, the one-piece core grip eliminates the need for a dead end steel compression barrel or a steel sleeve for full tension compression joints.

Factory Installed Eye

The dead end features a steel eye that is oriented and installed at the factory. This decreases installation time and eliminates costly field errors.

Factory Pre-filled

Quick Compress dead ends, joints, terminals and jumper connectors are pre-filled with AFL Filler Compound (AFC) and capped to prevent loss of compound prior to installation, eliminating an installation step.

High Voltage Applications

The end tapers of all compression accessories are supplied with a high voltage finish for die sizes 12CD and above. Corona bolts are furnished standard on 15° terminals for these section sizes. The square edges of bolted pads of the compression accessories could cause Corona. Pads with rounded edges and corners can be supplied by adding the catalog suffix 'EHV'.



Quick Reference Guide for Quick Compress Accessories for ACSR Conductor

CODE WORD	CONDUCTOR			COMPRESSION ACCESSORIES													
	SIZE	STRANDING	DIA.	DEAD END ASSEMBLIES						JOINT	JUMPER CONNECTOR	TERMINAL CONNECTORS			OPEN RUN TEE CONNECTOR	OPEN RUN TEE TAP	REPAIR SLEEVE
	KCMIL	AL/ST	IN	VERT. EYE SINGLE TONGUE	HOR. EYE SINGLE TONGUE	VERT. EYE DOUBLE TONGUE	HOR. EYE DOUBLE TONGUE	ADJ. EYE SINGLE TONGUE	ADJ. CLEVIS SINGLE TONGUE			STRAIGHT	15°	90°			
Waxwing	266.8	18/1	0.609	VES072	HES072	VED072	HED072	AES072	ACS072	CJ072	JC07	TS07	TF07	TN07	TTOC07	TTOP07	RS07
Owl	266.8	6/7	0.633	VES075	HES075	VED075	HED075	AES075	ACS075	CJ075	JC07	TS07	TF07	TN07	TTOC07	TTOP07	RS07
Partridge	266.8	26/7	0.642	VES076	HES076	VED076	HED076	AES076	ACS076	CJ076	JC07	TS07	TF07	TN07	TTOC07	TTOP07	RS07
Ostrich	300.0	26/7	0.680	VES085	HES085	VED085	HED085	AES085	ACS085	CJ085	JC08	TS08	TF08	TN08	TTOC08	TTOP08	RS08
Merlin	336.4	18/1	0.684	VES082	HES082	VED082	HED082	AES082	ACS082	CJ082	JC08	TS08	TF08	TN08	TTOC08	TTOP08	RS08
Linnet	336.4	26/7	0.720	VES086	HES086	VED086	HED086	AES086	ACS086	CJ086	JC08	TS08	TF08	TN08	TTOC08	TTOP08	RS08
Oriole	336.4	30/7	0.741	VES096	HES096	VED096	HED096	AES096	ACS096	CJ096	JC09	TS09	TF09	TN09	TTOC09	TTOP09	RS09
Chickadee	397.5	18/1	0.743	VES083	HES083	VED083	HED083	AES083	ACS083	CJ083	JC08	TS08	TF08	TN08	TTOC08	TTOP08	RS08
Brant	397.5	24/7	0.772	VES095	HES095	VED095	HED095	AES095	ACS095	CJ095	JC09	TS09	TF09	TN09	TTOC09	TTOP09	RS09
Ibis	397.5	26/7	0.783	VES096	HES096	VED096	HED096	AES096	ACS096	CJ096	JC09	TS09	TF09	TN09	TTOC09	TTOP09	RS09
Lark	397.5	30/7	0.806	VES106	HES106	VED106	HED106	AES106	ACS106	CJ106	JC10	TS10	TF10	TN10	TTOC10	TTOP10	RS10
Pelican	477.0	18/1	0.814	VES092	HES092	VED092	HED092	AES092	ACS092	CJ092	JC09	TS09	TF09	TN09	TTOC09	TTOP09	RS09
Flicker	477.0	24/7	0.846	VES095	HES095	VED095	HED095	AES095	ACS095	CJ095	JC09	TS09	TF09	TN09	TTOC09	TTOP09	RS09
Hawk	477.0	26/7	0.858	VES105	HES105	VED105	HED105	AES105	ACS105	CJ105	JC10	TS10	TF10	TN10	TTOC10	TTOP10	RS10
Hen	477.0	30/7	0.883	VES116	HES116	VED116	HED116	AES116	ACS116	CJ116	JC11	TS11	TF11	TN11	TTOC11	TTOP11	RS11
Osprey	556.5	18/1	0.879	VES102	HES102	VED102	HED102	AES102	ACS102	CJ102	JC10	TS10	TF10	TN10	TTOC10	TTOP10	RS10
Parakeet	556.5	24/7	0.914	VES105	HES105	VED105	HED105	AES105	ACS105	CJ105	JC10	TS10	TF10	TN10	TTOC10	TTOP10	RS10
Dove	556.5	26/7	0.927	VES106	HES106	VED106	HED106	AES106	ACS106	CJ106	JC10	TS10	TF10	TN10	TTOC10	TTOP10	RS10
Eagle	556.5	30/7	0.953	VES117	HES117	VED117	HED117	AES117	ACS117	CJ117	JC11	TS11	TF11	TN11	TTOC11	TTOP11	RS11
Peacock	605.0	24/7	0.953	VES115	HES115	VED115	HED115	AES115	ACS115	CJ115	JC11	TS11	TF11	TN11	TTOC11	TTOP11	RS11
Squab	605.0	26/7	0.966	VES116	HES116	VED116	HED116	AES116	ACS116	CJ116	JC11	TS11	TF11	TN11	TTOC11	TTOP11	RS11
Teal	605.0	30/19	0.994	VES126	HES126	VED126	HED126	AES126	ACS126	CJ126	JC12	TS12	TF12	TN12	TTOC12	TTOP12	RS12
Swift	636.0	36/1	0.930	VES101	HES101	VED101	HED101	AES101	ACS101	CJ101	JC10	TS10	TF10	TN10	TTOC10	TTOP10	RS10
Kingbird	636.0	18/1	0.940	VES103	HES103	VED103	HED103	AES103	ACS103	CJ103	JC10	TS10	TF10	TN10	TTOC10	TTOP10	RS10
Rook	636.0	24/7	0.978	VES115	HES115	VED115	HED115	AES115	ACS115	CJ115	JC11	TS11	TF11	TN11	TTOC11	TTOP11	RS11
Grosbeak	636.0	26/7	0.990	VES116	HES116	VED116	HED116	AES116	ACS116	CJ116	JC11	TS11	TF11	TN11	TTOC11	TTOP11	RS11
Egret	636.0	30/19	1.019	VES126	HES126	VED126	HED126	AES126	ACS126	CJ126	JC12	TS12	TF12	TN12	TTOC12	TTOP12	RS12
Flamingo	666.6	24/7	1.000	VES115	HES115	VED115	HED115	AES115	ACS115	CJ115	JC11	TS11	TF11	TN11	TTOC11	TTOP11	RS11
Stilt	715.5	24/7	1.036	VES115	HES115	VED115	HED115	AES115	ACS115	CJ115	JC11	TS11	TF11	TN11	TTOC11	TTOP11	RS11
Starling	715.5	26/7	1.051	VES126	HES126	VED126	HED126	AES126	ACS126	CJ126	JC12	TS12	TF12	TN12	TTOC12	TTOP12	RS12
Redwing	715.5	30/19	1.081	VES136	HES136	VED136	HED136	AES136	ACS136	CJ136	JC13	TS13	TF13	TN13	TTOC13	TTOP13	RS13
Coot	795.0	36/1	1.040	VES111	HES111	VED111	HED111	AES111	ACS111	CJ111	JC11	TS11	TF11	TN11	TTOC11	TTOP11	RS11
Tern	795.0	45/7	1.063	VES123	HES123	VED123	HED123	AES123	ACS123	CJ123	JC12	TS12	TF12	TN12	TTOC12	TTOP12	RS12
Cuckoo	795.0	24/7	1.092	VES125	HES125	VED125	HED125	AES125	ACS125	CJ125	JC12	TS12	TF12	TN12	TTOC12	TTOP12	RS12
Condor	795.0	54/7	1.092	VES125	HES125	VED125	HED125	AES125	ACS125	CJ125	JC12	TS12	TF12	TN12	TTOC12	TTOP12	RS12
Drake	795.0	26/7	1.108	VES126	HES126	VED126	HED126	AES126	ACS126	CJ126	JC12	TS12	TF12	TN12	TTOC12	TTOP12	RS12
Mallard	795.0	30/19	1.140	VES146	HES146	VED146	HED146	AES146	ACS146	CJ146	JC14	TS14	TF14	TN14	TTOC14	TTOP14	RS14
Ruddy	900.0	45/7	1.131	VES124	HES124	VED124	HED124	AES124	ACS124	CJ124	JC12	TS12	TF12	TN12	TTOC12	TTOP12	RS12
Canary	900.0	54/7	1.162	VES135	HES135	VED135	HED135	AES135	ACS135	CJ135	JC13	TS13	TF13	TN13	TTOC13	TTOP13	RS13
Catbird	954.0	36/1	1.140	VES121	HES121	VED121	HED121	AES121	ACS121	CJ121	JC12	TS12	TF12	TN12	TTOC12	TTOP12	RS12
Rail	954.0	45/7	1.165	VES133	HES133	VED133	HED133	AES133	ACS133	CJ133	JC13	TS13	TF13	TN13	TTOC13	TTOP13	RS13
Cardinal	954.0	54/7	1.196	VES135	HES135	VED135	HED135	AES135	ACS135	CJ135	JC13	TS13	TF13	TN13	TTOC13	TTOP13	RS13
Tanger	1033.5	36/1	1.186	VES131	HES131	VED131	HED131	AES131	ACS131	CJ131	JC13	TS13	TF13	TN13	TTOC13	TTOP13	RS13
Ortolan	1033.5	45/7	1.212	VES134	HES134	VED134	HED134	AES134	ACS134	CJ134	JC13	TS13	TF13	TN13	TTOC13	TTOP13	RS13

Quick Reference Guide for Quick Compress Accessories for ACSR Conductor (cont.)

CODE WORD	CONDUCTOR			COMPRESSION ACCESSORIES													
	SIZE	STRANDING	DIA.	DEAD END ASSEMBLIES						JOINT	JUMPER CONNECTOR	TERMINAL CONNECTORS			OPEN RUN TEE CONNECTOR	OPEN RUN TEE TAP	REPAIR SLEEVE
	KCMIL	AL/ST	IN	VERT. EYE SINGLE TONGUE	HOR. EYE SINGLE TONGUE	VERT. EYE DOUBLE TONGUE	HOR. EYE DOUBLE TONGUE	ADJ. EYE SINGLE TONGUE	ADJ. CLEVIS SINGLE TONGUE			STRAIGHT	15°	90°			
Curlwe	1033.5	54/7	1.246	VES145	HES145	VED145	HED145	AES145	ACS145	CJ145	JC14	TS14	TF14	TN14	TTOC14	TTOP14	RS14
Bluejay	1113.0	45/7	1.259	VES143	HES143	VED143	HED143	AES143	ACS143	CJ143	JC14	TS14	TF14	TN14	TTOC14	TTOP14	RS14
Finch	1113.0	54/19	1.293	VES145	HES145	VED145	HED145	AES145	ACS145	CJ145	JC14	TS14	TF14	TN14	TTOC14	TTOP14	RS14
Bunting	1192.5	45/7	1.302	VES144	HES144	VED144	HED144	AES144	ACS144	CJ144	JC14	TS14	TF14	TN14	TTOC14	TTOP14	RS14
Grackle	1192.5	54/19	1.333	VES155	HES155	VED155	HED155	AES155	ACS155	CJ155	JC15	TS15	TF15	TN15	TTOC15	TTOP15	RS15
Bittern	1272.0	45/7	1.345	VES153	HES153	VED153	HED153	AES153	ACS153	CJ153	JC15	TS15	TF15	TN15	TTOC15	TTOP15	RS15
Pheasant	1272.0	54/19	1.382	VES155	HES155	VED155	HED155	AES155	ACS155	CJ155	JC15	TS15	TF15	TN15	TTOC15	TTOP15	RS15
Dipper	1351.5	45/7	1.386	VES154	HES154	VED154	HED154	AES154	ACS154	CJ154	JC15	TS15	TF15	TN15	TTOC15	TTOP15	RS15
Martin	1351.5	54/19	1.424	VES155	HES155	VED155	HED155	AES155	ACS155	CJ155	JC15	TS15	TF15	TN15	TTOC15	TTOP15	RS15
Bobolink	1431.0	45/7	1.427	VES163	HES163	VED163	HED163	AES163	ACS163	CJ163	JC16	TS16	TF16	TN16	TTOC16	TTOP16	RS16
Plover	1431.0	54/19	1.465	VES165	HES165	VED165	HED165	AES165	ACS165	CJ165	JC16	TS16	TF16	TN16	TTOC16	TTOP16	RS16
Nuthatch	1510.5	45/7	1.466	VES164	HES164	VED164	HED164	AES164	ACS164	CJ164	JC16	TS16	TF16	TN16	TTOC16	TTOP16	RS16
Parrot	1510.5	54/19	1.505	VES165	HES165	VED165	HED165	AES165	ACS165	CJ165	JC16	TS16	TF16	TN16	TTOC16	TTOP16	RS16
Lapwing	1590.0	45/7	1.504	VES164	HES164	VED164	HED164	AES164	ACS164	CJ164	JC16	TS16	TF16	TN16	TTOC16	TTOP16	RS16
Falcon	1590.0	54/19	1.545	VES175	HES175	VED175	HED175	AES175	ACS175	CJ175	JC17	TS17	TF17	TN17	TTOC17	TTOP17	RS17
Chukar	1780.0	84/19	1.602	VES174	HES174	VED174	HED174	AES174	ACS174	CJ174	JC17	TS17	TF17	TN17	TTOC17	TTOP17	RS17
—	2034.0	72/7	1.681	VES183	HES183	VED183	HED183	AES183	ACS183	CJ183	JC18	TS18	TF18	TN18	TTOC18	TTOP18	RS18
Bluebird	2156.0	84/19	1.762	VES194	HES194	VED194	HED194	AES194	ACS194	CJ194	JC19	TS19	TF19	TN19	TTOC19	TTOP19	RS19
Kiwi	2167.0	72/7	1.735	VES193	HES193	VED193	HED193	AES193	ACS193	CJ193	JC19	TS19	TF19	TN19	TTOC19	TTOP19	RS19
Thrasher	2312.0	76/19	1.802	VES193	HES193	VED193	HED193	AES193	ACS193	CJ193	JC19	TS19	TF19	TN19	TTOC19	TTOP19	RS19
Joree	2515.0	76/19	1.880	VES203	HES203	VED203	HED203	AES203	ACS203	CJ203	JC20	TS20	TF20	TN20	TTOC20	TTOP20	RS20

Quick Reference Guide for Quick Compress Accessories for AAC Conductor

CODE WORD	CONDUCTOR			COMPRESSION ACCESSORIES													
	SIZE	STRANDING	DIA.	DEAD END ASSEMBLIES						JOINT	JUMPER CONNECTOR	TERMINAL CONNECTORS			OPEN RUN TEE CONNECTOR	OPEN RUN TEE TAP	REPAIR SLEEVE
	KCMIL	AL/ST	IN	VERT. EYE SINGLE TONGUE	HOR. EYE SINGLE TONGUE	VERT. EYE DOUBLE TONGUE	HOR. EYE DOUBLE TONGUE	ADJ. EYE SINGLE TONGUE	ADJ. CLEVIS SINGLE TONGUE			STRAIGHT	15°	90°			
Peony	300.0	19	0.629	VESE070	HESE070	VEDE070	HEDE070	AESE070	ACSE070	CJE07	JC07	TS07	TF07	TN07	TTOC07	TTOP07	RS07
Tulip	336.4	19	0.666	VESE070	HESE070	VEDE070	HEDE070	AESE070	ACSE070	CJE07	JC07	TS07	TF07	TN07	TTOC07	TTOP07	RS07
Daffodil	350.0	19	0.679	VESE070	HESE070	VEDE070	HEDE070	AESE070	ACSE070	CJE07	JC07	TS07	TF07	TN07	TTOC07	TTOP07	RS07
Canna	397.5	19	0.724	VESE080	HESE080	VEDE080	HEDE080	AESE080	ACSE080	CJE08	JC08	TS08	TF08	TN08	TTOC08	TTOP08	RS08
Goldentuft	450.0	19	0.770	VESE090	HESE090	VEDE090	HEDE090	AESE090	ACSE090	CJE09	JC09	TS09	TF09	TN09	TTOC09	TTOP09	RS09
Yarrow	450.0	37	0.770	VESE090	HESE090	VEDE090	HEDE090	AESE090	ACSE090	CJE09	JC09	TS09	TF09	TN09	TTOC09	TTOP09	RS09
Cosmos	477.0	19	0.793	VESE090	HESE090	VEDE090	HEDE090	AESE090	ACSE090	CJE09	JC09	TS09	TF09	TN09	TTOC09	TTOP09	RS09
Syringa	477.0	37	0.795	VESE090	HESE090	VEDE090	HEDE090	AESE090	ACSE090	CJE09	JC09	TS09	TF09	TN09	TTOC09	TTOP09	RS09
Zinnia	500.0	19	0.811	VESE090	HESE090	VEDE090	HEDE090	AESE090	ACSE090	CJE09	JC09	TS09	TF09	TN09	TTOC09	TTOP09	RS09
Hyacinth	500.0	37	0.813	VESE090	HESE090	VEDE090	HEDE090	AESE090	ACSE090	CJE09	JC09	TS09	TF09	TN09	TTOC09	TTOP09	RS09
Dahlia	556.5	19	0.856	VESE100	HESE100	VEDE100	HEDE100	AESE100	ACSE100	CJE10	JC10	TS10	TF10	TN10	TTOC10	TTOP10	RS10
Mistletoe	556.5	37	0.858	VESE100	HESE100	VEDE100	HEDE100	AESE100	ACSE100	CJE10	JC10	TS10	TF10	TN10	TTOC10	TTOP10	RS10
Meadowsweet	600.0	37	0.891	VESE100	HESE100	VEDE100	HEDE100	AESE100	ACSE100	CJE10	JC10	TS10	TF10	TN10	TTOC10	TTOP10	RS10
Orchid	636.0	37	0.918	VESE100	HESE100	VEDE100	HEDE100	AESE100	ACSE100	CJE10	JC10	TS10	TF10	TN10	TTOC10	TTOP10	RS10
Heuchera	650.0	37	0.928	VESE100	HESE100	VEDE100	HEDE100	AESE100	ACSE100	CJE10	JC10	TS10	TF10	TN10	TTOC10	TTOP10	RS10
Verbena	700.0	37	0.963	VESE110	HESE110	VEDE110	HEDE110	AESE110	ACSE110	CJE11	JC11	TS11	TF11	TN11	TTOC11	TTOP11	RS11
Flag	700.0	61	0.964	VESE110	HESE110	VEDE110	HEDE110	AESE110	ACSE110	CJE11	JC11	TS11	TF11	TN11	TTOC11	TTOP11	RS11
Violet	715.5	37	0.974	VESE110	HESE110	VEDE110	HEDE110	AESE110	ACSE110	CJE11	JC11	TS11	TF11	TN11	TTOC11	TTOP11	RS11
Nasturtium	715.5	61	0.975	VESE110	HESE110	VEDE110	HEDE110	AESE110	ACSE110	CJE11	JC11	TS11	TF11	TN11	TTOC11	TTOP11	RS11
Petunia	750.0	37	0.997	VESE110	HESE110	VEDE110	HEDE110	AESE110	ACSE110	CJE11	JC11	TS11	TF11	TN11	TTOC11	TTOP11	RS11
Cattail	750.0	61	0.998	VESE110	HESE110	VEDE110	HEDE110	AESE110	ACSE110	CJE11	JC11	TS11	TF11	TN11	TTOC11	TTOP11	RS11
Arbutus	795.0	37	1.026	VESE110	HESE110	VEDE110	HEDE110	AESE110	ACSE110	CJE11	JC11	TS11	TF11	TN11	TTOC11	TTOP11	RS11
Lilac	795.0	61	1.028	VESE110	HESE110	VEDE110	HEDE110	AESE110	ACSE110	CJE11	JC11	TS11	TF11	TN11	TTOC11	TTOP11	RS11
—	800.0	37	1.031	VESE110	HESE110	VEDE110	HEDE110	AESE110	ACSE110	CJE11	JC11	TS11	TF11	TN11	TTOC11	TTOP11	RS11
Heliotrope	800.0	61	1.031	VESE110	HESE110	VEDE110	HEDE110	AESE110	ACSE110	CJE11	JC11	TS11	TF11	TN11	TTOC11	TTOP11	RS11
Cockscomb	900.0	37	1.092	VESE120	HESE120	VEDE120	HEDE120	AESE120	ACSE120	CJE12	JC12	TS12	TF12	TN12	TTOC12	TTOP12	RS12
Snapdragon	900.0	61	1.094	VESE120	HESE120	VEDE120	HEDE120	AESE120	ACSE120	CJE12	JC12	TS12	TF12	TN12	TTOC12	TTOP12	RS12
Magnolia	954.0	37	1.124	VESE120	HESE120	VEDE120	HEDE120	AESE120	ACSE120	CJE12	JC12	TS12	TF12	TN12	TTOC12	TTOP12	RS12
Goldenrod	954.0	61	1.126	VESE120	HESE120	VEDE120	HEDE120	AESE120	ACSE120	CJE12	JC12	TS12	TF12	TN12	TTOC12	TTOP12	RS12
Hawkweed	1000.0	37	1.150	VESE130	HESE130	VEDE130	HEDE130	AESE130	ACSE130	CJE13	JC13	TS13	TF13	TN13	TTOC13	TTOP13	RS13
Camellia	1000.0	61	1.152	VESE130	HESE130	VEDE130	HEDE130	AESE130	ACSE130	CJE13	JC13	TS13	TF13	TN13	TTOC13	TTOP13	RS13
Bluebell	1033.5	37	1.170	VESE130	HESE130	VEDE130	HEDE130	AESE130	ACSE130	CJE13	JC13	TS13	TF13	TN13	TTOC13	TTOP13	RS13
Larkspur	1033.5	61	1.172	VESE130	HESE130	VEDE130	HEDE130	AESE130	ACSE130	CJE13	JC13	TS13	TF13	TN13	TTOC13	TTOP13	RS13
Marigold	1113.0	61	1.216	VESE130	HESE130	VEDE130	HEDE130	AESE130	ACSE130	CJE13	JC13	TS13	TF13	TN13	TTOC13	TTOP13	RS13
Hawthorn	1192.5	61	1.258	VESE140	HESE140	VEDE140	HEDE140	AESE140	ACSE140	CJE14	JC14	TS14	TF14	TN14	TTOC14	TTOP14	RS14
—	1250.0	127	1.289	VESE140	HESE140	VEDE140	HEDE140	AESE140	ACSE140	CJE14	JC14	TS14	TF14	TN14	TTOC14	TTOP14	RS14
Narcissus	1272.0	61	1.300	VESE140	HESE140	VEDE140	HEDE140	AESE140	ACSE140	CJE14	JC14	TS14	TF14	TN14	TTOC14	TTOP14	RS14
—	1300.0	127	1.315	VESE140	HESE140	VEDE140	HEDE140	AESE140	ACSE140	CJE14	JC14	TS14	TF14	TN14	TTOC14	TTOP14	RS14
Columbine	1351.0	61	1.340	VESE150	HESE150	VEDE150	HEDE150	AESE150	ACSE150	CJE15	JC15	TS15	TF15	TN15	TTOC15	TTOP15	RS15
Carnation	1431.0	61	1.379	VESE150	HESE150	VEDE150	HEDE150	AESE150	ACSE150	CJE15	JC15	TS15	TF15	TN15	TTOC15	TTOP15	RS15
—	1500.0	91	1.412	VESE150	HESE150	VEDE150	HEDE150	AESE150	ACSE150	CJE15	JC15	TS15	TF15	TN15	TTOC15	TTOP15	RS15
Gladiolus	1510.5	61	1.417	VESE150	HESE150	VEDE150	HEDE150	AESE150	ACSE150	CJE15	JC15	TS15	TF15	TN15	TTOC15	TTOP15	RS15
Coreopsis	1590.0	61	1.454	VESE160	HESE160	VEDE160	HEDE160	AESE160	ACSE160	CJE16	JC16	TS16	TF16	TN16	TTOC16	TTOP16	RS16
Dogwood	1590.0	91	1.454	VESE160	HESE160	VEDE160	HEDE160	AESE160	ACSE160	CJE16	JC16	TS16	TF16	TN16	TTOC16	TTOP16	RS16
Jessamine	1750.0	61	1.525	VESE170	HESE170	VEDE170	HEDE170	AESE170	ACSE170	CJE17	JC17	TS17	TF17	TN17	TTOC17	TTOP17	RS17
Cowslip	2000.0	91	1.630	VESE180	HESE180	VEDE180	HEDE180	AESE180	ACSE180	CJE18	JC18	TS18	TF18	TN18	TTOC18	TTOP18	RS18
Sagebrush	2250.0	91	1.729	VESE190	HESE190	VEDE190	HEDE190	AESE190	ACSE190	CJE19	JC19	TS19	TF19	TN19	TTOC19	TTOP19	RS19
—	2300.0	91	1.750	VESE190	HESE190	VEDE190	HEDE190	AESE190	ACSE190	CJE19	JC19	TS19	TF19	TN19	TTOC19	TTOP19	RS19
Lupine	2500.0	91	1.823	VESE200	HESE200	VEDE200	HEDE200	AESE200	ACSE200	CJE20	JC20	TS20	TF20	TN20	TTOC20	TTOP20	RS20



Quick Reference Guide for Quick Compress Accessories for AAC and ACAR Conductors

CONDUCTOR			COMPRESSION ACCESSORIES													
CODE WORD	SIZE	DIA.	DEAD END ASSEMBLIES						JOINT	JUMPER CONNECTOR	TERMINAL CONNECTORS			OPEN RUN TEE CONNECTOR	OPEN RUN TEE TAP	REPAIR SLEEVE
	KCMIL	IN	VERT. EYE SINGLE TONGUE	HOR. EYE SINGLE TONGUE	VERT. EYE DOUBLE TONGUE	HOR. EYE DOUBLE TONGUE	ADJ. EYE SINGLE TONGUE	ADJ. CLEVIS SINGLE TONGUE			STRAIGHT	15°	90°			
—	281.4	0.609	VES070	HES070	VED070	HED070	AES070	ACS070	CJ07	JC07	TS07	TF07	TN07	TTOC07	TTOP07	RS07
Butte	312.8	0.642	VES070	HES070	VED070	HED070	AES070	ACS070	CJ07	JC07	TS07	TF07	TN07	TTOC07	TTOP07	RS07
—	355.1	0.684	VES080	HES080	VED080	HED080	AES080	ACS080	CJ08	JC08	TS08	TF08	TN08	TTOC08	TTOP08	RS08
Canton	394.5	0.721	VES080	HES080	VED080	HED080	AES080	ACS080	CJ08	JC08	TS08	TF08	TN08	TTOC08	TTOP08	RS08
—	419.6	0.743	VES080	HES080	VED080	HED080	AES080	ACS080	CJ08	JC08	TS08	TF08	TN08	TTOC08	TTOP08	RS08
Cario	465.4	0.783	VES090	HES090	VED090	HED090	AES090	ACS090	CJ09	JC09	TS09	TF09	TN09	TTOC09	TTOP09	RS09
—	503.6	0.814	VES090	HES090	VED090	HED090	AES090	ACS090	CJ09	JC09	TS09	TF09	TN09	TTOC09	TTOP09	RS09
Darien	559.5	0.858	VES100	HES100	VED100	HED100	AES100	ACS100	CJ10	JC10	TS10	TF10	TN10	TTOC10	TTOP10	RS10
—	587.2	0.879	VES100	HES100	VED100	HED100	AES100	ACS100	CJ10	JC10	TS10	TF10	TN10	TTOC10	TTOP10	RS10
—	634.9	0.914	VES100	HES100	VED100	HED100	AES100	ACS100	CJ10	JC10	TS10	TF10	TN10	TTOC10	TTOP10	RS10
—	649.5	0.928	VES100	HES100	VED100	HED100	AES100	ACS100	CJ10	JC10	TS10	TF10	TN10	TTOC10	TTOP10	RS10
Elgin	652.4	0.927	VES100	HES100	VED100	HED100	AES100	ACS100	CJ10	JC10	TS10	TF10	TN10	TTOC10	TTOP10	RS10
—	657.3	0.930	VES100	HES100	VED100	HED100	AES100	ACS100	CJ10	JC10	TS10	TF10	TN10	TTOC10	TTOP10	RS10
Flint	740.8	0.991	VES110	HES110	VED110	HED110	AES110	ACS110	CJ11	JC11	TS11	TF11	TN11	TTOC11	TTOP11	RS11
—	853.7	1.063	VES120	HES120	VED120	HED120	AES120	ACS120	CJ12	JC12	TS12	TF12	TN12	TTOC12	TTOP12	RS12
Greeley	927.2	1.108	VES120	HES120	VED120	HED120	AES120	ACS120	CJ12	JC12	TS12	TF12	TN12	TTOC12	TTOP12	RS12
—	1024.5	1.165	VES130	HES130	VED130	HED130	AES130	ACS130	CJ13	JC13	TS13	TF13	TN13	TTOC13	TTOP13	RS13
—	1080.6	1.196	VES130	HES130	VED130	HED130	AES130	ACS130	CJ13	JC13	TS13	TF13	TN13	TTOC13	TTOP13	RS13
—	1108.6	1.212	VES130	HES130	VED130	HED130	AES130	ACS130	CJ13	JC13	TS13	TF13	TN13	TTOC13	TTOP13	RS13
—	1172.3	1.246	VES140	HES140	VED140	HED140	AES140	ACS140	CJ14	JC14	TS14	TF14	TN14	TTOC14	TTOP14	RS14
—	1534.0	1.427	VES160	HES160	VED160	HED160	AES160	ACS160	CJ16	JC16	TS16	TF16	TN16	TTOC16	TTOP16	RS16
—	1700.0	1.502	VES160	HES160	VED160	HED160	AES160	ACS160	CJ16	JC16	TS16	TF16	TN16	TTOC16	TTOP16	RS16
—	2303.5	1.750	VES190	HES190	VED190	HED190	AES190	ACS190	CJ19	JC19	TS19	TF19	TN19	TTOC19	TTOP19	RS19
—	2338.0	1.762	VES190	HES190	VED190	HED190	AES190	ACS190	CJ19	JC19	TS19	TF19	TN19	TTOC19	TTOP19	RS19
—	2493.0	1.821	VES200	HES200	VED200	HED200	AES200	ACS200	CJ20	JC20	TS20	TF20	TN20	TTOC20	TTOP20	RS20

Quick Compress Catalog Numbering System

The simplified AFL catalog numbering system for alloy compression connectors facilitates specifying, ordering and inventory control. The catalog number is stamped on each compression connector for easy and positive field identification.

Example: Catalog No. VES126

TYPE OF CONNECTOR	TUBE CODE	CORE GRIP CODE
VES (see table below)	① XX	②③ Y ⑤ Y N T

Example:

CONDUCTOR	DEAD END	CORE GRIP	DIE SIZE	TERMINAL	DEAD END ASSEMBLY
795.26/7 ACSR	VES12	CG126	12CD	TF12	VES126
927 kcmil-6201	VES12	–	12CD	TF12	VES120
954 kcmil-1350(EC)	VESE12	–	12CD	TF12	VES120

⑦ TYPE OF CONNECTOR	STANDARD U.S. SIZES			BRITISH, EUROPEAN AND STANDARD METRIC SIZES		
	ACSR	1350(EC)	ALLOY ACAR	ACSR	1350(EC)	ALLOY ACAR
Dead Ends, Vertical Eye, Single Tongue	VES	VESE	VES	VESM	VESEM	VESM
Dead Ends, Vertical Eye, Double Tongue	VED	VEDE	VED	VEDM	VEDEM	VEDM
Dead Ends, Horizontal Eye, Single Tongue	HES	HESE	HES	HESM	HESEM	HESM
Dead Ends, Horizontal Eye, Double Tongue	HED	HEDE	HED	HEDM	HEDEM	HEDM
Dead Ends, Adjustable Eye, Single Tongue	AES	AESE	AES	AESM	AESEM	AESM
Dead Ends, Adjustable Eye, Double Tongue	AED	AEDE	AED	AEDM	AEDEM	AEDM
Dead Ends, Adjustable Clevis, Single Tongue	ACS	ACSE	ACS	ACSM	ACSEM	ACSM
Dead Ends, Adjustable Clevis, Double Tongue	ACD	ACDE	ACD	ACDM	ACDEM	ACDM
Terminal Connectors, Straight Pad	TS	TS	TS	TSM	TSM	TSM
Terminal Connectors, 15° Pad ④	TF	TF	TF	TFM	TFM	TFM
Terminal Connectors, 45° Pad	T45	T45	T45	T45M	T45M	T45M
Terminal Connectors, 90° Pad	TN	TN	TN	TNM	TNM	TNM
Compression Joints	CJ	CJE	CJ	CJM	CJEM	CJM
Jumper Connector	JC	JC	JC	JCM	JCM	JCM
Repair Sleeve	RS	RS	RS	RSM	RSM	RSM
Core Grip	CG	–	–	CG	–	–
Tee Connector - Closed Run, Cable to Cable	TTCC	TTCC	TTCC	TTCCM	TTCCM	TTCCM
Tee Connector - Open Run, Cable to Cable	TTOC	TTOC	TTOC	TTOCM	TTOCM	TTOCM
Tee Tap - Closed Run, Cable to Pad	TTCP	TTCP	TTCP	TTCPM	TTCPM	TTCPM
Tee Tap - Open Run, Cable to Pad	TTOP	TTOP	TTOP	TTOPM	TTOPM	TTOPM

NOTES:

- ① The two digit number (denoted by XX) defines tube code. These numbers will be 07 through 21 inclusive.
- ② A single digit suffix (denoted by Y) is used to order the dead end assembly or joint assembly. This suffix also shows the core grip code. These numbers will be 0 through 7 inclusive, where 0 indicates no core grip and 1 through 7 indicates the core grip for a given tube size.
- ③ The dead end assembly for an ACSR consists of the prefilled aluminum dead end body precompressed onto the steel eye, the 15° terminal connector, hardware and core grip. Double tongue dead end assemblies include two terminal connectors. The joint assembly for ACSR consists of a prefilled aluminum sleeve and two core grips.
- ④ The dead end assembly for SAC conductors consists of the prefilled dead end body, precompressed onto the steel eye, the 15° terminal connector and hardware. Double tongue dead end assemblies include two terminal connectors.

- ⑤ To order dead end assembly without the jumper terminal, specify VESXXYNT. For the VES126NT, the assembly would consist of the VES12 dead end and CG126 core grip for the 795 26/7 ACSR.
- ⑥ The 15° terminal connectors are supplied with 1/2 inch aluminum alloy bolts, nuts and washers. Terminal sizes 12 and larger are supplied with corona bolts.
- ⑦ With the exception of repair sleeves, tee connectors and tee taps all of the compression barrels are prefilled with AFC.
- ⑧ Die code for compressors:

B – CD	Compressor Model: 12A
30 – CD	30A
60 – CD	60A
100 – CD	100A

Quick Compress Catalog Numbering System (cont.)

TUBE, CORE GRIP AND ASSEMBLY CODES FOR ACSR CONDUCTORS

CONDUCTOR SIZE			TUBE CODE XX	ASSEMBLY AND CORE GRIP CODE CG
KCMIL	MM ²	STRAND		
266.8	135.2	6/7	07	075
		18/1	07	072
		26/7	07	076
300.0	152.0	26/7	08	085
336.4	170.5	18/1	08	082
		26/7	08	086
		30/7	09	096
397.5	201.4	18/1	08	083
		24/7	09	095
		26/7	09	096
		30/7	10	106
477.0	241.7	18/1	09	092
		24/7	09	095
		26/7	10	096
		30/7	11	106
556.5	282.0	18/1	10	102
		24/7	10	105
		26/7	10	106
		30/7	11	117
605.0	306.8	24/7	11	115
		26/7	11	116
		30/19	12	126
636.0	322.3	18/1	10	103
		24/7	11	115
		26/7	11	116
		30/19	12	126
		36/1	10	101
666.8	337.7	24/7	11	115
715.5	362.6	24/7	11	115
		26/7	12	126
		30/19	13	138
795.0	402.8	24/7	12	125
		26/7	12	126
		30/19	14	146
		36/1	11	111
		45/7	12	123
54/7	12	125		
900.0	456.1	45/7	12	124
		54/7	13	135
954.0	483.4	36/1	12	121
		45/7	13	133
		54/7	13	135
1033.5	523.7	36/1	13	131
		45/7	13	134
		54/7	14	145
1113.0	583.9	45/7	14	143
		54/19	14	145

TUBE, CORE GRIP AND ASSEMBLY CODES FOR ACSR CONDUCTORS (cont.)

CONDUCTOR SIZE			TUBE CODE XX	ASSEMBLY AND CORE GRIP CODE CG
KCMIL	MM ²	STRAND		
1192.5	604.3	45/7	14	144
		54/19	15	155
1272.0	644.5	45/7	15	153
		54/19	15	153
1351.5	685.2	45/7	15	154
		54/19	15	155
1431.0	725.2	45/7	16	163
		54/19	16	165
1510.5	765.2	45/7	16	164
		54/19	16	165
1590.0	805.8	45/7	16	164
		54/19	17	175
1780.0	901.9	84/19	17	174
2034.0	1030.6	72/7	18	183
2156.0	1092.3	84/19	19	194
2167.0	1098.1	72/7	19	193
2312.0	1171.5	76/19	19	193
2515.0	1274.4	76/19	20	203

STRANDED ALUMINUM CONDUCTORS CONDUCTOR DIAMETER RANGE AND TUBE CODE

DIAMETER RANGE				TUBE CODE XX
INCHES		MILLIMETERS		
MIN.	MAX.	MIN.	MAX.	
.595	.680	15.1	17.3	07
.680	.765	17.3	19.4	08
.765	.855	19.4	21.7	09
.855	.950	21.7	24.1	10
.950	1.1045	24.1	26.5	11
1.045	1.140	26.5	29.0	12
1.140	1.235	29.0	31.4	13
1.235	1.330	31.4	33.8	14
1.330	1.425	33.8	36.2	15
1.425	1.520	36.2	38.6	16
1.520	1.615	38.6	41.0	17
1.615	1.710	41.0	43.4	18
1.710	1.805	43.4	45.8	19
1.805	1.900	45.8	48.3	20



Quick Compress®

QuickCompress®

Quick Compress Dead Ends for ACSR Conductor, Eye Type, Single Tongue, VES/HES Series

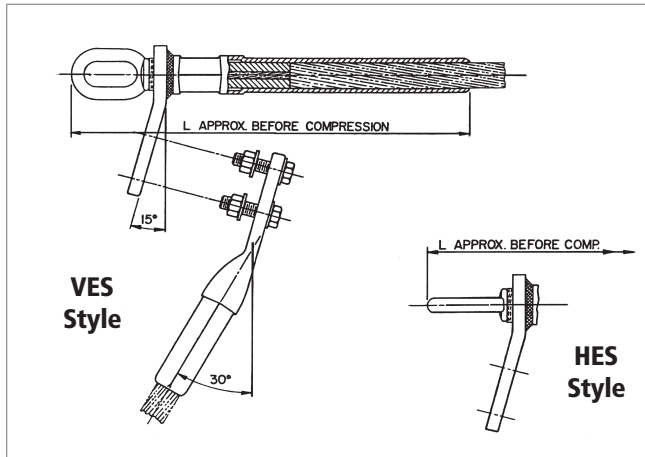

The Quick Compress Dead Ends are designed for fast and easy installation. By using a high strength alloy, the compression length has been shortened for less compression bites while maintaining a minimum 95% of the ASTM rated strength. The core grip eliminates the need for a steel compression barrel. The steel eye is pre-compressed and the dead end pre-filled, eliminating installation steps.

The dead end tongue and terminal pad are each constructed with a 15° angle, which permits the terminal connector to be bolted in either the straight or the 30° position. Both sides of the pad are finished, creating excellent electrical contact surfaces. For pad to pad connections, AFL recommends the use of No. 2 EJC.

The end tapers of all compression accessories are supplied with a high voltage finish for die sizes 12CD and above. Corona bolts are furnished standard on 15° terminals for these section sizes. The square edges of bolted pads of the compression accessories could cause Corona. Pads with rounded edges and corners can be supplied by adding the catalog suffix 'EHV'.

Ordering Instructions

Step 1: Assembly Catalog Number

Determine the assembly catalog number based on the conductor being used.

Step 2: Terminal Connector

For an assembly without a terminal connector, use 'NT'.
For an assembly with a terminal connector, leave blank.

Step 3: Extra High Voltage Finish

For Extra High Voltage Finish, use 'EHV'. (≥ 345 kV)
For Standard Finish, leave blank. (< 345 kV)

Step 4: Assemble Catalog Number



Example:

For a vertical eye dead end with no terminal and EHV finish for 795 Drake, the complete catalog number is:

VES126NTEHV

Notes:

1. Assembly Catalog Number includes dead end, core grip, terminal connector and aluminum hardware.
2. Eye Dimensions are on page 257.
3. Pad Dimensions are on page 257.
4. Installation Instructions for Dead Ends are on page 265.
5. Installation Instructions for Terminals are on page 272.
6. For more information on die selection and ordering instructions, see Tools and Equipment in this catalog.

Quick Compress Dead Ends for ACSR Conductor, Eye Type, Single Tongue, VES/HES Series (cont.)

ASSEMBLY CATALOG NUMBER		CONDUCTOR				DIE SIZE	TOTAL WEIGHT		DIMENSION L		PAD SIZE
		CODE WORD	SIZE	STRANDING	DIAMETER		LBS	KG	IN	MM	
			KCMIL	AL/ST	IN						
VES075	HES075	Owl	266.8	6/7	0.633	07CD	1.9	0.86	11.5	292	B
VES072	HES072	Waxwing	266.8	18/1	0.609	07CD	1.9	0.86	11.5	292	B
VES076	HES076	Partridge	266.8	26/7	0.642	07CD	1.9	0.86	11.5	292	B
VES085	HES085	Ostrich	300.0	26/7	0.680	08CD	2.4	1.09	12.3	313	B
VES082	HES082	Merlin	336.4	18/1	0.684	08CD	2.3	1.04	12.3	313	B
VES086	HES086	Linnet	336.4	26/7	0.720	08CD	2.4	1.09	12.3	313	B
VES096	HES096	Oriole	336.4	30/7	0.741	09CD	3.2	1.45	13.8	351	B
VES083	HES083	Chickadee	397.5	18/1	0.743	08CD	2.3	1.04	12.3	313	B
VES095	HES095	Brant	397.5	24/7	0.772	09CD	3.2	1.45	13.8	351	B
VES096	HES096	Ibis	397.5	26/7	0.783	09CD	3.2	1.45	13.8	351	B
VES106	HES106	Lark	397.5	30/7	0.806	10CD	3.7	1.68	14.7	373	B
VES092	HES092	Pelican	477.0	18/1	0.814	09CD	3.2	1.45	13.8	351	B
VES095	HES095	Flicker	477.0	24/7	0.846	09CD	3.2	1.45	13.8	351	B
VES105	HES105	Hawk	477.0	26/7	0.858	10CD	3.7	1.68	14.7	373	B
VES116	HES116	Hen	477.0	30/7	0.883	11CD	5.7	2.59	15.9	403	D
VES102	HES102	Osprey	556.5	18/1	0.879	10CD	3.7	1.68	14.7	373	B
VES105	HES105	Parakeet	556.5	24/7	0.914	10CD	3.7	1.68	14.7	373	B
VES106	HES106	Dove	556.5	26/7	0.927	10CD	3.7	1.68	14.7	373	B
VES117	HES117	Eagle	556.5	30/7	0.953	11CD	5.7	2.59	15.9	403	D
VES115	HES115	Peacock	605.0	24/7	0.953	11CD	5.7	2.59	15.9	403	D
VES116	HES116	Squab	605.0	26/7	0.966	11CD	5.7	2.59	15.9	403	D
VES126	HES126	Teal	605.0	30/19	0.994	12CD	6.5	2.59	16.7	424	D
VES103	HES103	Kingbird	636.0	18/1	0.940	10CD	3.7	1.68	14.7	373	B
VES115	HES115	Rook	636.0	24/7	0.977	11CD	5.7	2.59	15.9	403	D
VES116	HES116	Grosbeak	636.0	26/7	0.990	11CD	5.7	2.59	15.9	403	D
VES126	HES126	Egret	636.0	30/19	1.019	12CD	6.5	2.95	16.7	424	D
VES101	HES101	Swift	636.0	36/1	0.930	10CD	3.7	1.68	14.7	373	B
VES115	HES115	Flamingo	666.6	24/7	1.000	11CD	5.7	2.59	15.9	403	D
VES115	HES115	Stilt	715.5	24/7	1.036	11CD	5.7	2.59	15.9	403	D
VES126	HES126	Starling	715.5	26/7	1.051	12CD	6.5	2.95	16.7	424	D
VES136	HES136	Redwing	715.5	30/19	1.081	13CD	8.7	3.95	19.0	483	D
VES125	HES125	Cuckoo	795.0	24/7	1.092	12CD	6.5	2.95	16.7	424	D
VES126	HES126	Drake	795.0	26/7	1.108	12CD	6.5	2.95	16.7	424	D
VES146	HES146	Mallard	795.0	30/19	1.140	14CD	10.0	4.54	19.8	503	D
VES111	HES111	Coot	795.0	36/1	1.040	11CD	5.6	2.54	15.9	403	D

Quick Compress Dead Ends for ACSR Conductor, Eye Type, Single Tongue, VES/HES Series (cont.)

ASSEMBLY CATALOG NUMBER		CONDUCTOR				DIE SIZE	TOTAL WEIGHT		DIMENSION L		PAD SIZE
		CODE WORD	SIZE	STRANDING	DIAMETER		LBS	KG	IN	MM	
			KCMIL	AL/ST	IN						
VES123	HES123	Tern	795.0	45/7	1.063	12CD	6.5	2.95	16.7	424	D
VES125	HES125	Condor	795.0	54/7	1.093	12CD	6.5	2.95	16.7	424	D
VES124	HES124	Ruddy	900.0	45/7	1.131	12CD	6.5	2.95	16.7	424	D
VES135	HES135	Canary	900.0	54/7	1.162	13CD	8.7	3.95	19.0	483	D
VES121	HES121	Catbird	954.0	36/1	1.140	12CD	6.4	2.90	16.7	424	D
VES133	HES133	Rail	954.0	45/7	1.165	13CD	8.6	3.90	19.0	483	D
VES135	HES135	Cardinal	954.0	54/7	1.196	13CD	8.7	3.95	19.0	483	D
VES131	HES131	Tanger	1033.5	36/1	1.186	13CD	8.5	3.86	19.0	483	D
VES134	HES134	Oriolian	1033.5	45/7	1.212	13CD	8.6	3.90	19.0	483	D
VES145	HES145	Curlew	1033.5	54/7	1.244	14CD	9.9	4.49	19.8	503	D
VES143	HES143	Bluejay	1113.0	45/7	1.259	14CD	9.9	4.49	19.8	503	D
VES145	HES145	Finch	1113.0	54/19	1.293	14CD	9.9	4.49	19.8	503	D
VES144	HES144	Bunting	1192.5	45/7	1.302	14CD	9.9	4.49	19.8	503	D
VES155	HES155	Grackle	1192.5	54/19	1.333	15CD	11.0	4.99	20.6	524	D
VES153	HES153	Bittern	1272.0	45/7	1.345	15CD	10.9	4.49	20.6	524	D
VES155	HES155	Pheasant	1272.0	54/19	1.382	15CD	11.0	4.99	20.6	524	D
VES154	HES154	Dipper	1351.5	45/7	1.385	15CD	11.0	4.99	20.6	524	D
VES155	HES155	Martin	1351.5	54/19	1.424	15CD	11.0	4.99	20.6	524	D
VES163	HES163	Bobolink	1431.0	45/7	1.427	16CD	13.8	6.26	22.3	567	D
VES165	HES165	Plover	1431.0	54/19	1.465	16CD	13.9	6.30	22.3	567	D
VES164	HES164	Nuthatch	1510.5	45/7	1.466	16CD	13.8	6.26	22.3	567	D
VES165	HES165	Parrot	1510.5	54/19	1.506	16CD	13.9	6.30	22.3	567	D
VES164	HES164	Lapwing	1590.0	45/7	1.504	16CD	13.8	6.26	22.3	567	D
VES175	HES175	Falcon	1590.0	54/19	1.545	17CD	17.1	7.76	23.1	586	E
VES174	HES174	Chukar	1780.0	84/19	1.602	17CD	17.0	7.71	23.1	586	E
VES183	HES183	—	2034.0	72/7	1.681	18CD	18.5	8.39	23.9	607	E
VES194	HES194	Bluebird	2156.0	84/19	1.762	19CD	23.5	10.66	26.2	665	E
VES193	HES193	Kiwi	2167.0	72/7	1.737	19CD	23.4	10.61	26.2	665	E
VES193	HES193	Thrasher	2312.0	76/19	1.802	19CD	23.4	10.61	26.2	665	E
VES203	HES203	Joree	2515.0	76/19	1.880	20CD	24.9	11.29	27.0	686	E

Quick Compress Dead Ends for ACSR Conductor, Eye Type, Double Tongue, VED/HED Series

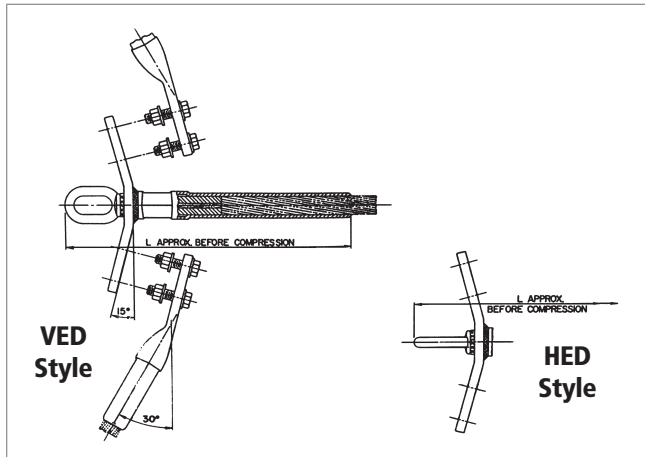

The Quick Compress Dead Ends are designed for fast and easy installation. By using a high strength alloy, the compression length has been shortened for less compression bites while maintaining a minimum 95% of the ASTM rated strength. The core grip eliminates the need for a steel compression barrel. The steel eye is precom-pressed and the dead end pre-filled, eliminating installation steps.

The dead end tongue and terminal pad are each constructed with a 15° angle, which permits the terminal connector to be bolted in either the straight or the 30° position. Both sides of the pad are finished, creating excellent electrical contact surfaces. For pad to pad connections, AFL recommends the use of No. 2 EJC.

The end tapers of all compression accessories are supplied with a high voltage finish for die sizes 12CD and above. Corona bolts are furnished standard on 15° terminals for these section sizes. The square edges of bolted pads of the compression accessories could cause Corona. Pads with rounded edges and corners can be supplied by adding the catalog suffix 'EHV'.

Ordering Instructions

Step 1: Assembly Catalog Number

Determine the assembly catalog number based on the conductor being used.

Step 2: Terminal Connector

For an assembly without a terminal connector, use 'NT'.
For an assembly with a terminal connector, leave blank.

Step 3: Extra High Voltage Finish

For Extra High Voltage Finish, use 'EHV'. (≥ 345 kV)
For Standard Finish, leave blank. (< 345 kV)

Step 4: Assemble Catalog Number.



Example:

For a vertical eye dead end with no terminal and EHV finish for 795 Drake, the complete catalog number is:

VED128NTEHV

Notes:

1. Assembly Catalog Number includes dead end, core grip, two terminal connectors and aluminum hardware.
2. Eye Dimensions are on page 257.
3. Pad Dimensions are on page 257.
4. Installation Instructions for Dead Ends are on page 265.
5. Installation Instructions for Terminals are on page 272.
6. For more information on die selection and ordering instructions, see Tools and Equipment in this catalog.



Quick Compress Dead Ends for ACSR Conductor, Eye Type, Double Tongue, VED/HED Series (cont.)

ASSEMBLY CATALOG NUMBER		CONDUCTOR				DIE SIZE	TOTAL WEIGHT		DIMENSION L		PAD SIZE
VERTICAL EYE	HORIZONTAL EYE	CODE WORD	SIZE	STRANDING	DIAMETER		LBS	KG	IN	MM	
			KCMIL	AL/ST	IN						
VED075	HED075	Owl	266.8	6/7	0.633	07CD	2.8	1.27	11.5	292	B
VED072	HED072	Waxwing	266.8	18/1	0.609	07CD	2.8	1.27	11.5	292	B
VED076	HED076	Partridge	266.8	26/7	0.642	07CD	2.8	1.27	11.5	292	B
VED085	HED085	Ostrich	300.0	26/7	0.680	08CD	3.4	1.54	12.3	313	B
VED082	HED082	Merlin	336.4	18/1	0.684	08CD	3.4	1.54	12.3	313	B
VED086	HED086	Linnet	336.4	26/7	0.720	08CD	3.4	1.54	12.3	313	B
VED096	HED096	Oriole	336.4	30/7	0.741	09CD	4.4	2.00	13.8	351	B
VED083	HED083	Chickadee	397.5	18/1	0.743	08CD	3.4	1.54	12.3	313	B
VED095	HED095	Brant	397.5	24/7	0.772	09CD	4.4	2.00	13.8	351	B
VED096	HED096	Ibis	397.5	26/7	0.783	09CD	4.4	2.00	13.8	351	B
VED106	HED106	Lark	397.5	30/7	0.806	10CD	5.3	2.40	14.7	373	B
VED092	HED092	Pelican	477.0	18/1	0.814	09CD	4.3	1.95	13.8	351	B
VED095	HED095	Flicker	477.0	24/7	0.846	09CD	4.3	1.95	13.8	351	B
VED105	HED105	Hawk	477.0	26/7	0.858	10CD	5.3	2.40	14.7	373	B
VED116	HED116	Hen	477.0	30/7	0.883	11CD	7.9	3.58	15.9	403	D
VED102	HED102	Osprey	556.5	18/1	0.879	10CD	5.3	2.40	14.7	373	B
VED105	HED105	Parakeet	556.5	24/7	0.914	10CD	5.3	2.40	14.7	373	B
VED106	HED106	Dove	556.5	26/7	0.927	10CD	5.3	2.40	14.7	373	B
VED117	HED117	Eagle	556.5	30/7	0.953	11CD	7.9	3.58	15.9	403	D
VED115	HED115	Peacock	605.0	24/7	0.953	11CD	7.9	3.58	15.9	403	D
VED116	HED116	Squab	605.0	26/7	0.966	11CD	7.9	3.58	15.9	403	D
VED126	HED126	Teal	605.0	30/19	0.994	12CD	9.2	4.17	16.7	424	D
VED103	HED103	Kingbird	636.0	18/1	0.940	10CD	5.3	2.4	14.7	373	B
VED115	HED115	Rook	636.0	24/7	0.977	11CD	7.9	3.58	15.9	403	D
VED116	HED116	Grosbeak	636.0	26/7	0.990	11CD	7.9	3.58	15.9	403	D
VED126	HED126	Egret	636.0	30/19	1.019	12CD	9.2	4.17	16.7	424	D
VED101	HED101	Swift	636.0	36/1	0.930	10CD	5.3	2.40	14.7	373	B
VED115	HED115	Flamingo	666.6	24/7	1.000	11CD	7.9	3.58	15.9	403	D
VED115	HED115	Stilt	715.5	24/7	1.036	11CD	7.9	3.58	15.9	403	D
VED126	HED126	Starling	715.5	26/7	1.051	12CD	9.2	4.17	16.7	424	D
VED136	HED136	Redwing	715.5	30/19	1.081	13CD	11.8	5.36	19.0	483	D
VED125	HED125	Cuckoo	795.0	24/7	1.092	12CD	9.2	4.17	16.7	424	D
VED126	HED126	Drake	795.0	26/7	1.108	12CD	9.2	4.17	16.7	424	D
VED146	HED146	Mallard	795.0	30/19	1.140	14CD	13.6	6.17	19.8	503	D
VED111	HED111	Coot	795.0	36/1	1.040	11CD	7.8	3.64	15.9	403	D



Quick Compress Dead Ends for ACSR Conductor, Eye Type, Double Tongue, VED/HED Series (cont.)

ASSEMBLY CATALOG NUMBER		CONDUCTOR				DIE SIZE	TOTAL WEIGHT		DIMENSION L		PAD SIZE
VERTICAL EYE	HORIZONTAL EYE	CODE WORD	SIZE	STRANDING	DIAMETER		LBS	KG	IN	MM	
			KCMIL	AL/ST	IN						
VED123	HED123	Tern	795.0	45/7	1.063	12CD	9.2	4.17	16.7	424	D
VED125	HED125	Condor	795.0	54/7	1.093	12CD	9.2	4.17	16.7	424	D
VED124	HED124	Ruddy	900.0	45/7	1.131	12CD	9.2	4.17	16.7	424	D
VED135	HED135	Canary	900.0	54/7	1.162	13CD	11.8	5.35	19.0	483	D
VED121	HED121	Catbird	954.0	36/1	1.140	12CD	9.1	4.13	16.7	424	D
VED133	HED133	Rail	954.0	45/7	1.165	13CD	11.7	5.31	19.0	483	D
VED135	HED135	Cardinal	954.0	54/7	1.196	13CD	11.8	5.35	19.0	483	D
VED131	HED131	Tanger	1033.5	36/1	1.186	13CD	11.6	5.26	19.0	483	D
VED134	HED134	Ortolan	1033.5	45/7	1.212	13CD	11.7	5.31	19.0	483	D
VED145	HED145	Curlew	1033.5	54/7	1.244	14CD	13.5	6.12	19.8	503	D
VED143	HED143	Bluejay	1113.0	45/7	1.259	14CD	13.5	6.12	19.8	503	D
VED145	HED145	Finch	1113.0	54/19	1.293	14CD	13.5	6.12	19.8	503	D
VED144	HED144	Bunting	1192.5	45/7	1.302	14CD	13.5	6.12	19.8	503	D
VED155	HED155	Grackle	1192.5	54/19	1.333	15CD	15.0	6.80	20.6	524	D
VED153	HED153	Bittern	1272.0	45/7	1.345	15CD	14.9	6.76	20.6	524	D
VED155	HED155	Pheasant	1272.0	54/19	1.382	15CD	15.0	6.80	20.6	524	D
VED154	HED154	Dipper	1351.5	45/7	1.385	15CD	15.0	6.80	20.6	524	D
VED155	HED155	Martin	1351.5	54/19	1.424	15CD	15.0	6.80	20.6	524	D
VED163	HED163	Bobolink	1431.0	45/7	1.427	16CD	18.4	8.35	22.3	567	D
VED165	HED165	Plover	1431.0	54/19	1.465	16CD	18.5	8.39	22.3	567	D
VED164	HED164	Nuthatch	1510.5	45/7	1.466	16CD	18.4	8.35	22.3	567	D
VED165	HED165	Parrot	1510.5	54/19	1.506	16CD	18.5	8.39	22.3	567	D
VED164	HED164	Lapwing	1590.0	45/7	1.504	16CD	18.4	8.35	22.3	567	D
VED175	HED175	Falcon	1590.0	54/19	1.545	17CD	22.8	10.34	23.1	586	E
VED174	HED174	Chukar	1780.0	84/19	1.602	17CD	22.8	10.34	23.1	586	E
VED183	HED183	-----	2034.0	72/7	1.681	18CD	24.8	11.25	23.9	607	E
VED194	HED194	Bluebird	2156.0	84/19	1.762	19CD	30.9	14.02	26.2	665	E
VED193	HED193	Kiwi	2167.0	72/7	1.737	19CD	30.8	13.97	26.2	665	E
VED193	HED193	Thrasher	2312.0	76/19	1.802	19CD	30.8	13.97	26.2	665	E
VED203	HED203	Joree	2515.0	76/19	1.880	20CD	32.7	14.83	27.0	686	E

QuickCompress® - ACSR

Quick Compress Dead Ends for ACSR Conductor, Adjustable Clevis Type, Single Tongue, ACS Series

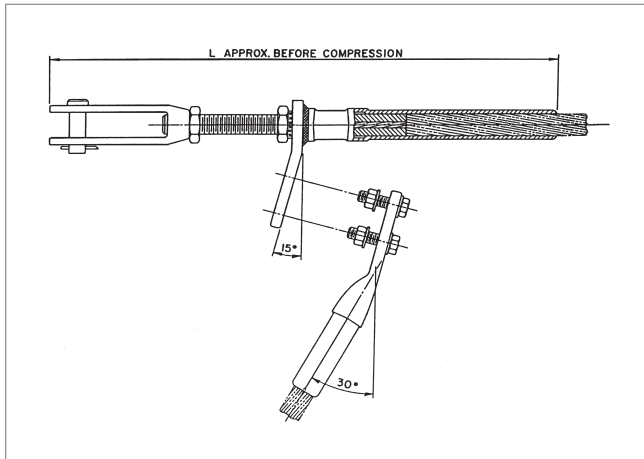

The Quick Compress Dead Ends are designed for fast and easy installation. By using a high strength alloy, the compression length has been shortened for less compression bites while maintaining a minimum 95% of the ASTM rated strength. The core grip eliminates the need for a steel compression barrel. The adjustable steel clevis is pre-compressed and the dead end pre-filled, eliminating installation steps.

The dead end tongue and terminal pad are each constructed with a 15° angle, which permits the terminal connector to be bolted in either the straight or the 30° position. Both sides of the pad are finished, creating excellent electrical contact surfaces. For pad to pad connections, AFL recommends the use of No. 2 EJC.

The end tapers of all compression accessories are supplied with a high voltage finish for die sizes 12CD and above. Corona bolts are furnished standard on 15° terminals for these section sizes. The square edges of bolted pads of the compression accessories could cause Corona. Pads with rounded edges and corners can be supplied by adding the catalog suffix 'EHV'.

Ordering Instructions

Step 1: Assembly Catalog Number

Determine the assembly catalog number based on the conductor being used.

Step 2: Terminal Connector

For an assembly without a terminal connector, use 'NT'.
For an assembly with a terminal connector, leave blank.

Step 3: Extra High Voltage Finish

For Extra High Voltage Finish, use 'EHV'. (≥ 345 kV)
For Standard Finish, leave blank. (< 345 kV)

Step 4: Assemble Catalog Number.



Example:

For an adjustable clevis dead end with no terminal and EHV finish for 795 Drake, the complete catalog number is:

ACS126NTEHV

Notes:

1. Assembly Catalog Number includes dead end, core grip, terminal connector and aluminum hardware.
2. Clevis Dimensions are on page 258.
3. Pad Dimensions are on page 257.
4. Installation Instructions for Dead Ends are on page 265.
5. Installation Instructions for Terminals are on page 272.
6. For more information on die selection and ordering instructions, see Tools and Equipment tab in this catalog.



Quick Compress Dead Ends for ACSR Conductor, Adjustable Clevis Type, Single Tongue, ACS Series (cont.)

ASSEMBLY CATALOG NUMBER	CONDUCTOR				DIE SIZE	TOTAL WEIGHT		DIMENSION L		PAD SIZE
	CODE NAME	SIZE	STRANDING	DIAMETER		LBS	KG	IN	MM	
		KCMIL	AL/ST	IN						
ACS075	Owl	266.8	6/7	0.633	07CD	4.4	2.00	19.3	489	B
ACS072	Waxwing	266.8	18/1	0.609	07CD	4.4	2.00	19.3	489	B
ACS076	Partridge	266.8	26/7	0.642	07CD	4.4	2.00	19.3	489	B
ACS085	Ostrich	300.0	26/7	0.680	08CD	5.2	2.36	20.2	513	B
ACS082	Merlin	336.4	18/1	0.684	08CD	5.1	2.31	20.2	513	B
ACS086	Linnet	336.4	26/7	0.720	08CD	5.2	2.36	20.2	513	B
ACS096	Oriole	336.4	30/7	0.741	09CD	6.3	2.86	21.7	551	B
ACS083	Chickadee	397.5	18/1	0.743	08CD	5.1	2.31	20.2	513	B
ACS095	Brant	397.5	24/7	0.772	09CD	6.3	2.86	21.7	551	B
ACS096	Ibis	397.5	26/7	0.783	09CD	6.3	2.86	21.7	551	B
ACS106	Lark	397.5	30/7	0.806	10CD	6.8	3.08	22.5	572	B
ACS092	Pelican	477.0	18/1	0.814	09CD	6.3	2.86	21.7	551	B
ACS095	Flicker	477.0	24/7	0.846	09CD	6.3	2.86	21.7	551	B
ACS105	Hawk	477.0	26/7	0.858	10CD	6.8	3.08	22.5	572	B
ACS116	Hen	477.0	30/7	0.883	11CD	11.3	5.13	25.9	659	D
ACS102	Osprey	556.5	18/1	0.879	10CD	6.8	3.08	22.5	572	B
ACS105	Parakeet	556.5	24/7	0.914	10CD	6.8	3.08	22.5	572	B
ACS106	Dove	556.5	26/7	0.927	10CD	6.8	3.08	22.5	572	B
ACS117	Eagle	556.5	30/7	0.953	11CD	11.3	5.13	25.9	659	D
ACS115	Peacock	605.0	24/7	0.953	11CD	11.3	5.13	25.9	659	D
ACS116	Squab	605.0	26/7	0.966	11CD	11.3	5.13	25.9	659	D
ACS126	Teal	605.0	30/19	0.994	12CD	12.1	5.49	26.8	679	D
ACS103	Kingbird	636.0	18/1	0.940	10CD	6.8	3.08	22.5	572	B
ACS115	Rook	636.0	24/7	0.977	11CD	11.3	5.13	25.9	659	D
ACS116	Grosbeak	636.0	26/7	0.990	11CD	11.3	5.13	25.9	659	D
ACS126	Egret	636.0	30/19	1.019	12CD	12.1	5.49	26.8	679	D
ACS101	Swift	636.0	36/1	0.930	10CD	6.8	3.08	22.5	572	B
ACS115	Flamingo	666.6	24/7	1.000	11CD	11.3	5.13	25.9	659	D
ACS115	Stilt	715.5	24/7	1.036	11CD	11.3	5.13	25.9	659	D
ACS126	Starling	715.5	26/7	1.051	12CD	12.1	5.49	26.8	679	D
ACS136	Redwing	715.5	30/19	1.081	13CD	15.3	6.94	28.7	729	D
ACS125	Cuckoo	795.0	24/7	1.092	12CD	12.1	5.49	26.8	679	D
ACS126	Drake	795.0	26/7	1.108	12CD	12.1	5.49	26.8	679	D
ACS146	Mallard	795.0	30/19	1.140	14CD	16.5	7.48	29.5	749	D
ACS111	Coot	795.0	36/1	1.040	11CD	11.2	5.08	25.9	659	D
ACS123	Tern	795.0	45/7	1.063	12CD	12.1	5.49	26.8	679	D
ACS125	Condor	795.0	54/7	1.093	12CD	12.1	5.49	26.8	679	D

QuickCompress® - ACSR



Quick Compress Dead Ends for ACSR Conductor, Adjustable Clevis Type, Single Tongue, ACS Series (cont.)

ASSEMBLY CATALOG NUMBER	CONDUCTOR				DIE SIZE	TOTAL WEIGHT		DIMENSION L		PAD SIZE
	CODE NAME	SIZE	STRANDING	DIAMETER		LBS	KG	IN	MM	
		KCMIL	AL/ST	IN						
ACS124	Ruddy	900.0	45/7	1.131	12CD	12.1	5.49	26.8	679	D
ACS135	Canary	900.0	54/7	1.162	13CD	15.3	6.94	28.7	729	D
ACS121	Catbird	954.0	36/1	1.140	12CD	12.0	5.44	26.8	679	D
ACS133	Rail	954.0	45/7	1.165	13CD	15.2	6.89	28.7	729	D
ACS135	Cardinal	954.0	54/7	1.196	13CD	15.3	6.94	28.7	729	D
ACS131	Tanger	1033.5	36/1	1.186	13CD	15.1	6.85	28.7	729	D
ACS134	Ortolan	1033.5	45/7	1.212	13CD	15.2	6.89	28.7	729	D
ACS145	Curlew	1033.5	54/7	1.244	14CD	16.4	7.44	29.5	749	D
ACS143	Bluejay	1113.0	45/7	1.259	14CD	16.4	7.44	29.5	749	D
ACS145	Finch	1113.0	54/19	1.293	14CD	16.4	7.44	29.5	749	D
ACS144	Bunting	1192.5	45/7	1.302	14CD	16.4	7.44	29.5	749	D
ACS155	Grackle	1192.5	54/19	1.333	15CD	17.5	7.94	31.3	770	D
ACS153	Bittern	1272.0	45/7	1.345	15CD	17.4	7.89	30.3	770	D
ACS155	Pheasant	1272.0	54/19	1.382	15CD	17.5	7.94	30.3	770	D
ACS154	Dipper	1351.5	45/7	1.385	15CD	17.5	7.94	30.3	770	D
ACS155	Martin	1351.5	54/19	1.424	15CD	17.5	7.94	30.3	770	D
ACS163	Bobolink	1431.0	45/7	1.427	16CD	23.9	10.84	34.4	873	D
ACS165	Plover	1431.0	54/19	1.465	16CD	24.0	10.89	34.4	873	D
ACS164	Nuthatch	1510.5	45/7	1.466	16CD	23.9	10.84	34.4	873	D
ACS165	Parrot	1510.5	54/19	1.506	16CD	24.0	10.89	34.4	873	D
ACS164	Lapwing	1590.0	45/7	1.504	16CD	23.9	10.84	34.4	873	D
ACS175	Falcon	1590.0	54/19	1.545	17CD	27.2	12.34	35.3	895	E
ACS174	Chukar	1780.0	84/19	1.602	17CD	27.1	12.29	35.3	895	E
ACS183	-----	2034.0	72/7	1.681	18CD	28.6	12.97	36.0	914	E
ACS194	Bluebird	2156.0	84/19	1.762	19CD	37.3	16.92	38.2	970	E
ACS193	Kiwi	2167.0	72/7	1.737	19CD	37.2	16.87	38.2	970	E
ACS193	Thrasher	2312.0	74/19	1.802	19CD	37.2	16.87	38.2	970	E
ACS203	Joree	2515.0	74/19	1.880	20CD	38.6	17.51	39.0	991	E

Quick Compress Dead Ends for ACSR Conductor, Adjustable Eye Type, Single Tongue, AES Series

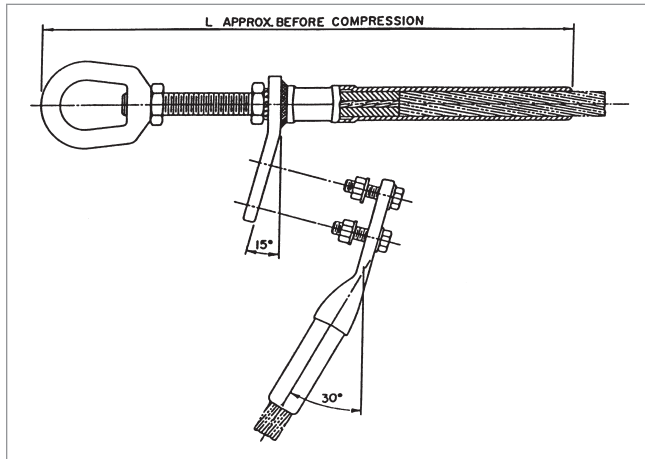

The Quick Compress Dead Ends are designed for fast and easy installation. By using a high strength alloy, the compression length has been shortened for less compression bites while maintaining a minimum 95% of the ASTM rated strength. The core grip eliminates the need for a steel compression barrel. The adjustable steel eye is pre-compressed and the dead end pre-filled, eliminating installation steps.

The dead end tongue and terminal pad are each constructed with a 15° angle, which permits the terminal connector to be bolted in either the straight or the 30° position. Both sides of the pad are finished, creating excellent electrical contact surfaces. For pad to pad connections, AFL recommends the use of No. 2 EJC.

The end tapers of all compression accessories are supplied with a high voltage finish for die sizes 12CD and above. Corona bolts are furnished standard on 15° terminals for these section sizes.

The square edges of bolted pads of the compression accessories could cause Corona. Pads with rounded edges and corners can be supplied by adding the catalog suffix 'EHV'.

Ordering Instructions

Step 1: Assembly Catalog Number

Determine the assembly catalog number based on the conductor being used.

Step 2: Terminal Connector

For an assembly without a terminal connector, use 'NT'.

For an assembly with a terminal connector, leave blank.

Step 3: Extra High Voltage Finish

For Extra High Voltage Finish, use 'EHV'. (≥ 345 kV)

For Standard Finish, leave blank. (< 345 kV)

Step 4: Assemble Catalog Number.



Example:

For an adjustable eye dead end with no terminal and EHV finish for 795 Drake, the complete catalog number is:

AES126NTEHV

Notes:

1. Assembly Catalog Number includes dead end, core grip, terminal connector and aluminum hardware.
2. Eye Dimensions are on page 258.
3. Pad Dimensions are on page 257.
4. Installation Instructions for Dead Ends are on page 265.
5. Installation Instructions for Terminals are on page 272.
6. For more information on die selection and ordering instructions, see Tools and Equipment tab in this catalog.



Quick Compress Dead Ends for ACSR Conductor, Adjustable Eye Type, Single Tongue, AES Series (cont.)

ASSEMBLY CATALOG NUMBER	CONDUCTOR				DIE SIZE	TOTAL WEIGHT		DIMENSION L		PAD SIZE
	CODE WORD	SIZE	STRANDING	DIAMETER		LBS	KG	IN	MM	
		KCMIL	AL/ST	IN						
AES075	Owl	266.8	6/7	0.633	07CD	2.7	1.22	16.4	418	B
AES072	Waxwing	266.8	18/1	0.609	07CD	2.7	1.22	16.4	418	B
AES076	Partridge	266.8	26/7	0.642	07CD	2.7	1.22	16.4	418	B
AES085	Ostrich	300.0	26/7	0.680	08CD	3.9	1.77	17.8	453	B
AES082	Merlin	336.4	18/1	0.684	08CD	3.8	1.72	17.8	453	B
AES086	Linnet	336.4	26/7	0.720	08CD	3.9	1.77	17.8	453	B
AES096	Oriole	336.4	30/7	0.741	09CD	5.7	2.59	19.7	501	B
AES083	Chickadee	397.5	18/1	0.743	08CD	3.8	1.72	17.8	453	B
AES095	Brant	397.5	24/7	0.772	09CD	5.7	2.59	19.7	501	B
AES096	Ibis	397.5	26/7	0.783	09CD	5.7	2.59	19.7	501	B
AES106	Lark	397.5	30/7	0.806	10CD	6.2	2.81	20.5	521	B
AES092	Pelican	477.0	18/1	0.814	09CD	5.7	2.59	19.7	501	B
AES095	Flicker	477.0	24/7	0.846	09CD	5.7	2.59	19.7	501	B
AES105	Hawk	477.0	26/7	0.858	10CD	6.2	2.81	20.5	521	B
AES116	Hen	477.0	30/7	0.883	11CD	9.3	4.22	23.3	591	D
AES102	Osprey	556.5	18/1	0.879	10CD	6.2	2.81	20.5	521	B
AES105	Parakeet	556.5	24/7	0.914	10CD	6.2	2.81	20.5	521	B
AES106	Dove	556.5	26/7	0.927	10CD	6.2	2.81	20.5	521	B
AES117	Eagle	556.5	30/7	0.953	11CD	9.3	4.22	23.3	591	D
AES115	Peacock	605.0	24/7	0.953	11CD	9.3	4.22	23.3	591	D
AES116	Squab	605.0	26/7	0.966	11CD	9.3	4.22	23.3	591	D
AES126	Teal	605.0	30/19	0.994	12CD	10.1	4.58	24.1	611	D
AES103	Kingbird	636.0	18/1	0.940	10CD	6.2	2.81	20.5	521	B
AES115	Rook	636.0	24/7	0.977	11CD	9.3	4.22	23.3	591	D
AES116	Grosbeak	636.0	26/7	0.990	11CD	9.3	4.22	23.3	591	D
AES126	Egret	636.0	30/19	1.019	12CD	10.1	4.58	24.1	611	D
AES101	Swift	636.0	36/1	0.930	10CD	6.2	2.81	20.5	521	B
AES115	Flamingo	666.6	24/7	1.000	11CD	9.3	4.22	23.3	591	D
AES115	Stilt	715.5	24/7	1.036	11CD	9.3	4.22	23.3	591	D
AES126	Starling	715.5	26/7	1.051	12CD	10.1	4.58	24.1	611	D
AES136	Redwing	715.5	30/19	1.081	13CD	14.2	6.44	26.5	673	D
AES125	Cuckoo	795.0	24/7	1.092	12CD	10.1	4.58	24.1	611	D
AES126	Drake	795.0	26/7	1.108	12CD	10.1	4.58	24.1	611	D
AES146	Mallard	795.0	30/19	1.140	14CD	15.4	6.99	27.3	694	D
AES111	Coot	795.0	36/1	1.040	11CD	9.2	4.17	23.3	591	D
AES123	Tern	795.0	45/7	1.063	12CD	10.1	4.58	24.1	611	D



Quick Compress Dead Ends for ACSR Conductor, Adjustable Eye Type, Single Tongue, AES Series (cont.)

ASSEMBLY CATALOG NUMBER	CONDUCTOR				DIE SIZE	TOTAL WEIGHT		DIMENSION L		PAD SIZE
	CODE WORD	SIZE	STRANDING	DIAMETER		LBS	KG	IN	MM	
		KCMIL	AL/ST	IN						
AES125	Condor	795.0	54/7	1.093	12CD	10.1	4.58	24.1	611	D
AES124	Ruddy	900.0	45/7	1.131	12CD	10.1	4.58	24.1	611	D
AES135	Canary	900.0	54/7	1.162	13CD	14.2	6.44	26.5	673	D
AES121	Catbird	954.0	36/1	1.140	12CD	10.1	4.54	24.1	611	D
AES133	Rail	954.0	45/7	1.165	13CD	14.1	6.40	26.5	673	D
AES135	Cardinal	954.0	54/7	1.196	13CD	14.2	6.44	26.5	673	D
AES131	Tanger	1033.5	36/1	1.186	13CD	14.0	6.35	26.5	673	D
AES134	Ortolan	1033.5	45/7	1.212	13CD	14.1	6.40	26.5	673	D
AES145	Curlew	1033.5	54/7	1.244	14CD	15.3	6.94	27.3	694	D
AES143	Bluejay	1113.0	45/7	1.259	14CD	15.3	6.94	27.3	694	D
AES145	Finch	1113.0	54/19	1.293	14CD	15.3	6.94	27.3	694	D
AES144	Bunting	1192.5	45/7	1.302	14CD	15.3	6.94	27.3	694	D
AES155	Grackle	1192.5	54/19	1.333	15CD	16.5	7.48	28.1	714	D
AES153	Bittern	1272.0	45/7	1.345	15CD	16.4	7.44	28.1	714	D
AES155	Pheasant	1272.0	54/19	1.382	15CD	16.5	7.48	28.1	714	D
AES154	Dipper	1351.5	45/7	1.385	15CD	16.5	7.48	28.1	714	D
AES155	Martin	1351.5	54/19	1.424	15CD	16.5	7.48	28.1	714	D
AES163	Bobolink	1431.0	45/7	1.427	16CD	23.6	10.70	31.7	806	D
AES165	Plover	1431.0	54/19	1.465	16CD	23.7	10.75	31.7	806	D
AES164	Nuthatch	1510.5	45/7	1.466	16CD	23.6	10.70	31.7	806	D
AES165	Parrot	1510.5	54/19	1.506	16CD	23.7	10.75	31.7	806	D
AES164	Lapwing	1590.0	45/7	1.504	16CD	23.6	10.70	31.7	806	D
AES175	Falcon	1590.0	54/19	1.545	17CD	26.9	12.20	32.5	826	E
AES174	Chukar	1780.0	84/19	1.602	17CD	26.8	12.16	32.5	826	E
AES183	—	2034.0	72/7	1.681	18CD	26.3	12.84	33.3	845	E
AES194	Bluebird	2156.0	84/19	1.762	19CD	34.1	15.47	35.2	895	E
AES193	Kiwi	2167.0	72/7	1.737	19CD	34.0	15.42	35.2	895	E
AES193	Thrasher	2312.0	76/19	1.802	19CD	34.0	15.42	35.2	895	E
AES203	Joree	2515.0	76/19	1.880	20CD	35.7	16.19	36.1	915	E

QuickCompress® - ACSR

Quick Compress Compression Joints for ACSR Conductor, CJ Series

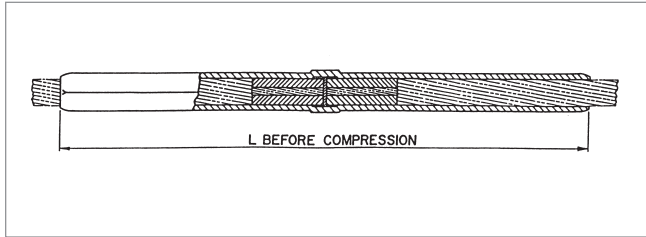

The Quick Compress CJ Series Joints are designed for fast and easy installation. By using a high strength alloy, the compression length has been shortened for less compression bites while maintaining a minimum 95% of the ASTM rated strength. The core grip eliminates the need for a steel sleeve. The compression joint is pre-filled, eliminating an installation step. Each compression joint has a center stop to ensure proper insertion of the conductor.

The end tapers of all compression accessories are supplied with a high voltage finish for die size sections 12CD and above.

Ordering Instructions

Step 1: Assembly Catalog Number

Determine the assembly catalog number based on the conductor being used.

Example:

A compression joint for 795 Drake conductor, the complete catalog number is:

CJ126

Notes:

1. Assembly Catalog Number includes one aluminum joint and two core grips.
2. Installation Instructions for Compression Joints are on page 269.
3. For more information on die selection and ordering instructions, see Tools and Equipment tab in this catalog.

ASSEMBLY CATALOG NUMBER	CONDUCTOR				DIE SIZE	TOTAL WEIGHT		DIMENSION L	
	CODE WORD	SIZE	STRANDING	DIAMETER		LBS	KG	IN	MM
		KCMIL	AL	IN					
CJ075	Owl	266.8	6/7	0.633	07CD	0.7	0.30	11.2	284
CJ072	Waxwing	266.8	18/1	0.609	07CD	0.6	0.29	11.2	284
CJ076	Partridge	266.8	26/7	0.642	07CD	0.7	0.30	11.2	284
CJ085	Ostrich	300.0	26/7	0.680	08CD	1.0	0.44	12.8	325
CJ082	Merlin	336.4	18/1	0.684	08CD	0.9	0.43	12.8	325
CJ086	Linnet	336.4	26/7	0.720	08CD	1.0	0.45	12.8	325
CJ096	Oriole	336.4	30/7	0.741	09CD	1.4	0.64	14.4	366
CJ083	Chickadee	397.5	18/1	0.743	08CD	1.0	0.45	12.8	325
CJ095	Brant	397.5	24/7	0.772	09CD	1.4	0.64	14.4	366
CJ096	Ibis	397.5	26/7	0.783	09CD	1.4	0.64	14.4	366
CJ106	Lark	397.5	30/7	0.806	10CD	2.0	0.91	16.0	406
CJ092	Pelican	477.0	18/1	0.814	09CD	1.3	0.59	14.4	366
CJ095	Flicker	477.0	24/7	0.846	09CD	1.4	0.64	14.4	366
CJ105	Hawk	477.0	26/7	0.858	10CD	1.9	0.86	16.0	406
CJ116	Hen	477.0	30/7	0.883	11CD	2.6	1.18	17.6	447
CJ102	Osprey	556.5	18/1	0.879	10CD	1.9	0.86	16.0	406
CJ105	Parakeet	556.5	24/7	0.914	10CD	2.0	0.91	16.0	406
CJ106	Dove	556.5	26/7	0.927	10CD	2.7	1.22	16.0	447
CJ117	Eagle	556.5	30/7	0.953	11CD	2.6	1.18	17.6	447
CJ115	Peacock	605.0	24/7	0.953	11CD	2.6	1.18	17.6	447
CJ116	Squab	605.0	26/7	0.966	11CD	3.4	1.54	17.6	488
CJ126	Teal	605.0	30/19	0.994	12CD	1.9	0.86	19.2	406

Quick Compress Compression Joints for ACSR Conductor, CJ Series (cont.)

ASSEMBLY CATALOG NUMBER	CONDUCTOR				DIE SIZE	TOTAL WEIGHT		DIMENSION L	
	CODE WORD	SIZE	STRANDING	DIAMETER		LBS	KG	IN	MM
		KCMIL	AL	IN					
CJ103	Kingbird	636.0	18/1	0.940	10CD	2.6	1.18	16.0	447
CJ115	Rook	636.0	24/7	0.977	11CD	2.6	1.18	17.6	447
CJ116	Grosbeak	636.0	26/7	0.990	11CD	3.4	1.54	17.6	488
CJ126	Egret	636.0	30/19	1.019	12CD	1.8	0.82	19.2	406
CJ101	Swift	636.0	36/1	0.930	10CD	2.6	1.18	16.0	447
CJ115	Flamingo	666.6	24/7	1.000	11CD	2.6	1.18	17.6	447
CJ115	Stilt	715.5	24/7	1.036	11CD	3.4	1.54	17.6	488
CJ126	Starling	715.5	26/7	1.051	12CD	4.4	2.00	19.2	528
CJ136	Redwing	715.5	30/19	1.081	13CD	3.4	1.54	20.8	488
CJ125	Cuckoo	795.0	24/7	1.092	12CD	3.4	1.54	19.2	488
CJ126	Drake	795.0	26/7	1.108	12CD	5.3	2.40	19.2	569
CJ146	Mallard	795.0	30/19	1.140	14CD	2.5	1.13	22.4	447
CJ111	Coot	795.0	36/1	1.040	11CD	3.3	1.50	17.6	488
CJ123	Tern	795.0	45/7	1.063	12CD	3.4	1.54	19.2	488
CJ125	Condor	795.0	54/7	1.093	12CD	3.4	1.54	19.2	488
CJ124	Ruddy	900.0	45/7	1.131	12CD	4.3	1.95	19.2	523
CJ135	Canary	900.0	54/7	1.162	13CD	3.2	1.45	20.8	488
CJ121	Catbird	954.0	36/1	1.140	12CD	4.2	1.91	19.2	528
CJ133	Rail	954.0	45/7	1.165	13CD	4.3	1.95	20.8	528
CJ135	Cardinal	954.0	54/7	1.196	13CD	4.1	1.86	20.8	528
CJ131	Tanger	1033.5	36/1	1.186	13CD	4.3	1.95	20.8	528
CJ134	Ortolan	1033.5	45/7	1.212	13CD	5.2	2.36	20.8	569
CJ145	Curlew	1033.5	54/7	1.244	14CD	5.1	2.31	22.4	569
CJ143	Bluejay	1113.0	45/7	1.259	14CD	5.2	2.36	22.4	569
CJ145	Finch	1113.0	54/19	1.293	14CD	5.2	2.36	22.4	569
CJ144	Bunting	1192.5	45/7	1.302	14CD	6.4	2.90	22.4	610
CJ155	Grackle	1192.5	54/19	1.333	15CD	6.2	2.81	24.0	610
CJ153	Bittern	1272.0	45/7	1.345	15CD	6.4	2.90	24.0	610
CJ155	Pheasant	1272.0	54/19	1.382	15CD	6.3	2.86	24.0	610
CJ154	Dipper	1351.5	45/7	1.385	15CD	6.4	2.90	24.0	610
CJ155	Martin	1351.5	54/19	1.424	15CD	7.6	3.45	24.0	650
CJ163	Bobolink	1431.0	45/7	1.427	16CD	7.9	3.58	25.6	650
CJ165	Plover	1431.0	54/19	1.465	16CD	7.8	3.54	25.6	650
CJ164	Nuthatch	1510.5	45/7	1.466	16CD	7.9	3.58	25.6	650
CJ165	Parrot	1510.5	54/19	1.506	16CD	7.8	3.54	25.6	650
CJ164	Lapwing	1590.0	45/7	1.504	16CD	9.5	4.31	25.6	691
CJ175	Falcon	1590.0	54/19	1.545	17CD	9.3	4.22	27.2	691
CJ174	Chukar	1780.0	84/19	1.602	17CD	10.9	4.94	27.2	732
CJ183	—	2034.0	72/7	1.681	18CD	13.0	5.90	28.8	772
CJ194	Bluebird	2156.0	84/19	1.762	19CD	12.8	5.81	30.4	772
CJ193	Kiwi	2167.0	72/7	1.737	19CD	12.8	5.81	30.4	772
CJ193	Thrasher	2312.0	76/19	1.802	19CD	12.8	5.81	30.4	772
CJ203	Joree	2515.0	76/19	1.880	20CD	14.5	6.58	32.0	813

Quick Compress Replacement Compression Joints for ACSR Conductor, CJR Series

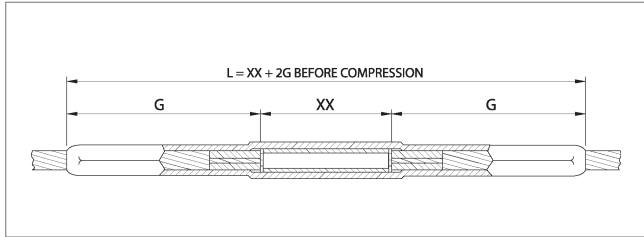

The Quick Compress Replacement Joints are used to replace damaged conductor in midspan. They are designed for fast and easy installation. By using a high strength alloy, the compression length has been shortened for less compression bits, while maintaining a minimum 95% of the ASTM rated strength. The replacement joint is pre-filled, eliminating an installation step.

The end tapers of all compression accessories are supplied with a high voltage finish for die size sections 12CD and above.

Ordering Instructions

Step 1: Assembly Catalog Number

Determine the assembly catalog number based on the conductor being used.

Step 2: Determine Length of Conductor Removed (XX)

Determine the length of conductor (XX) that will be cut out, to the nearest inch (Maximum 48").

Step 3: Assemble Catalog Number

Catalog Number	+	Removed Conductor Length (XX)
----------------	---	-------------------------------

Example:

A replacement compression joint for 795 Drake conductor with a removed conductor length of 24 inches, the complete catalog number is:

CJ126R24

Notes:

1. Assembly Catalog Number includes one aluminum joint and two core grips.
2. Installation Instructions for Compression Joints are on page 269.
3. For more information on die selection and ordering instructions, see Tools and Equipment tab in this catalog.

ASSEMBLY CATALOG NUMBER	CONDUCTOR				DIE SIZE	DIMENSION G	
	CODE WORD	SIZE	STRANDING	DIAMETER		IN	MM
		KCMIL	AL/ST	IN			
CJ075RXX	Owl	266.8	6/7	0.633	07CD	7.56	192
CJ072RXX	Waxwing	266.8	18/1	0.609	07CD	7.56	192
CJ076RXX	Partridge	266.8	26/7	0.642	07CD	7.56	192
CJ085RXX	Ostrich	300.0	26/7	0.680	08CD	8.36	212
CJ082RXX	Merlin	336.4	18/1	0.684	08CD	8.36	212
CJ086RXX	Linnet	336.4	26/7	0.720	08CD	8.36	212
CJ096RXX	Oriole	336.4	30/7	0.741	09CD	9.16	233
CJ083RXX	Chickadee	397.5	18/1	0.743	08CD	8.36	212
CJ095RXX	Brant	397.5	24/7	0.772	09CD	9.16	233
CJ096RXX	Ibis	397.5	26/7	0.783	09CD	9.16	233
CJ106RXX	Lark	397.5	30/7	0.806	10CD	9.96	253
CJ092RXX	Pelican	477.0	18/1	0.814	09CD	9.16	233
CJ095RXX	Flicker	477.0	24/7	0.846	09CD	9.16	233
CJ105RXX	Hawk	477.0	26/7	0.858	10CD	9.96	253
CJ116RXX	Hen	477.0	30/7	0.883	11CD	10.76	273
CJ102RXX	Osprey	556.5	18/1	0.879	10CD	9.96	253
CJ105RXX	Parakeet	556.5	24/7	0.914	10CD	9.96	253
CJ106RXX	Dove	556.5	26/7	0.927	10CD	9.96	253
CJ117RXX	Eagle	556.5	30/7	0.953	11CD	10.76	273
CJ115RXX	Peacock	605.0	24/7	0.953	11CD	10.76	273

Quick Compress Replacement Compression Joints for ACSR Conductor, CJR Series (cont.)

ASSEMBLY CATALOG NUMBER	CONDUCTOR				DIE SIZE	DIMENSION G	
	CODE WORD	SIZE	STRANDING	DIAMETER		IN	MM
		KCMIL	AL/ST	IN			
CJ116RXX	Squab	605.0	26/7	0.966	11CD	10.76	273
CJ126RXX	Teal	605.0	30/19	0.994	12CD	11.66	294
CJ103RXX	Kingbird	636.0	18/1	0.940	10CD	9.96	253
CJ115RXX	Rook	636.0	24/7	0.977	11CD	10.76	273
CJ116RXX	Grosbeak	636.0	26/7	0.990	11CD	10.76	273
CJ126RXX	Egret	636.0	30/19	1.019	12CD	11.56	294
CJ101RXX	Swift	636.0	36/1	0.930	10CD	9.96	253
CJ115RXX	Flamingo	666.6	24/7	1.000	11CD	10.76	273
CJ115RXX	Stilt	715.5	24/7	1.036	11CD	10.76	273
CJ126RXX	Starling	715.5	26/7	1.051	12CD	11.56	294
CJ136RXX	Redwing	715.5	30/19	1.081	13CD	12.36	314
CJ125RXX	Cuckoo	795.0	24/7	1.092	12CD	11.56	294
CJ126RXX	Drake	795.0	26/7	1.108	12CD	11.56	294
CJ146RXX	Mallard	795.0	30/19	1.140	14CD	13.16	334
CJ111RXX	Coot	795.0	36/1	1.040	11CD	10.76	273
CJ123RXX	Tern	795.0	45/7	1.063	12CD	11.56	294
CJ125RXX	Condor	795.0	54/7	1.093	12CD	11.56	294
CJ124RXX	Ruddy	900.0	45/7	1.131	12CD	11.56	294
CJ135RXX	Canary	900.0	54/7	1.162	13CD	12.36	314
CJ121RXX	Catbird	954.0	36/1	1.140	12CD	11.56	294
CJ133RXX	Rail	954.0	45/7	1.165	13CD	12.36	314
CJ135RXX	Cardinal	954.0	54/7	1.196	13CD	12.36	314
CJ131RXX	Tanager	1033.5	36/1	1.186	13CD	12.36	314
CJ134RXX	Ortolan	1033.5	45/7	1.212	13CD	12.36	314
CJ145RXX	Curlew	1033.5	54/7	1.244	14CD	13.16	334
CJ143RXX	Bluejay	1113.0	45/7	1.259	14CD	13.16	334
CJ145RXX	Finch	1113.0	54/19	1.293	14CD	13.16	334
CJ144RXX	Bunting	1192.5	45/7	1.302	14CD	13.16	334
CJ155RXX	Grackle	1192.5	54/19	1.333	15CD	13.96	355
CJ153RXX	Bittern	1272.0	45/7	1.345	15CD	13.96	355
CJ155RXX	Pheasant	1272.0	54/19	1.382	15CD	13.96	355
CJ154RXX	Dipper	1351.5	45/7	1.385	15CD	13.96	355
CJ155RXX	Martin	1351.5	54/19	1.424	15CD	13.96	355
CJ163RXX	Bobolink	1431.0	45/7	1.427	16CD	14.76	375
CJ165RXX	Plover	1431.0	54/19	1.465	16CD	14.76	375
CJ164RXX	Nuthatch	1510.5	45/7	1.466	16CD	14.76	375
CJ165RXX	Parrot	1510.5	54/19	1.506	16CD	14.76	375
CJ164RXX	Lapwing	1590.0	45/7	1.504	16CD	14.76	375
CJ175RXX	Falcon	1590.0	54/19	1.545	17CD	15.56	395
CJ174RXX	Chukar	1780.0	84/19	1.602	17CD	15.56	395
CJ183RXX	—	2034.0	72/7	1.681	18CD	16.36	416
CJ194RXX	Bluebird	2156.0	84/19	1.762	19CD	17.16	436
CJ193RXX	Kiwi	2167.0	72/7	1.737	19CD	17.16	436
CJ193RXX	Thrasher	2312.0	76/19	1.802	19CD	17.16	436
CJ203RXX	Joree	2515.0	76/19	1.880	20CD	17.96	456

Quick Compress Repair Sleeve for ACSR Conductor, RS Series

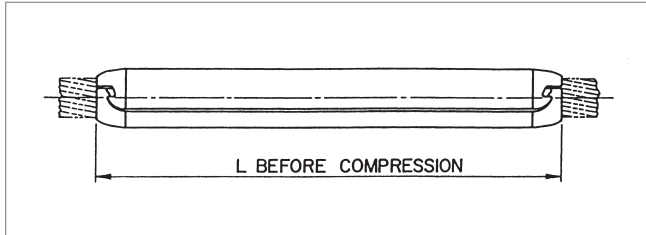

The Quick Compress Repair Sleeve is designed for ACSR, AAC, AAAC and ACAR conductors. The repair sleeve incorporates an improved design of interlocking extrusions, providing a permanent grip on the conductor when compressed.

The repair sleeve will restore the conductor to 95% of its ASTM rated strength where up to one-third of the aluminum strands are damaged.

Ordering Instructions

Step 1: Assembly Catalog Number

Determine the assembly catalog number based on the conductor being used.

Example:

A repair sleeve for 795 Drake conductor, the complete catalog number is:

RS12

Notes:

1. Installation Instructions for Compression Joints are on page 270.
2. For more information on die selection and ordering instructions, see the AFL Tool Catalog.

AFL NO.	CONDUCTOR				DIE SIZE	TOTAL WEIGHT		DIMENSION L	
	CODE WORD	SIZE	STRANDING	DIAMETER		LBS	KG	IN	MM
		KCMIL	AL/ST	IN					
RS07	Owl	266.8	6/7	0.633	07CD	0.4	0.17	8.4	213
RS07	Waxwing	266.8	18/1	0.609	07CD	0.4	0.17	8.4	213
RS07	Partridge	266.8	26/7	0.642	07CD	0.4	0.17	8.4	213
RS08	Ostrich	300.0	26/7	0.680	08CD	0.6	0.26	9.6	244
RS08	Merlin	336.4	18/1	0.684	08CD	0.6	0.26	9.6	244
RS08	Linnet	336.4	26/7	0.720	08CD	0.6	0.26	9.6	244
RS09	Oriole	336.4	30/7	0.741	09CD	0.8	0.38	10.8	274
RS08	Chickadee	397.5	18/1	0.743	08CD	0.6	0.26	9.6	244
RS09	Brant	397.5	24/7	0.772	09CD	0.8	0.38	10.8	274
RS09	Ibis	397.5	26/7	0.783	09CD	0.8	0.38	10.8	274
RS10	Lark	397.5	30/7	0.806	10CD	1.1	0.50	12.0	305
RS09	Pelican	477.0	18/1	0.814	09CD	0.8	0.38	10.8	274
RS09	Flicker	477.0	24/7	0.846	09CD	0.8	0.38	10.8	274
RS10	Hawk	477.0	26/7	0.858	10CD	1.1	0.50	12.0	305
RS11	Hen	477.0	30/7	0.883	11CD	1.5	0.68	13.2	335
RS10	Osprey	556.5	18/1	0.879	10CD	1.1	0.50	12.0	305
RS10	Parakeet	556.5	24/7	0.914	10CD	1.1	0.50	12.0	305
RS10	Dove	556.5	26/7	0.927	10CD	1.1	0.50	12.0	305
RS11	Eagle	556.5	30/7	0.953	11CD	1.5	0.68	13.2	335
RS11	Peacock	605.0	24/7	0.953	11CD	1.5	0.68	13.2	335
RS11	Squab	605.0	26/7	0.966	11CD	1.5	0.68	13.2	335
RS12	Teal	605.0	30/19	0.994	12CD	1.9	0.86	14.4	355
RS10	Kingbird	636.0	18/1	0.940	10CD	1.1	0.50	12.0	305
RS11	Rook	636.0	24/7	0.977	11CD	1.5	0.68	13.2	335



Quick Compress Repair Sleeve for ACSR Conductor, RS Series (cont.)

QuickCompress® – ACSR

AFL NO.	CONDUCTOR				DIE SIZE	TOTAL WEIGHT		DIMENSION L	
	CODE WORD	SIZE	STRANDING	DIAMETER		LBS	KG	IN	MM
		KCMIL	AL/ST	IN					
RS11	Grosbeak	636.0	26/7	0.990	11CD	1.5	0.68	13.2	335
RS12	Egret	636.0	30/19	1.019	12CD	1.9	0.86	14.4	355
RS10	Swift	636.0	36/1	0.930	10CD	1.1	0.50	12.0	305
RS11	Flamingo	666.6	24/7	1.000	11CD	1.5	0.68	13.2	335
RS11	Stilt	715.5	24/7	1.036	11CD	1.5	0.68	13.2	335
RS12	Starling	715.5	26/7	1.051	12CD	1.9	0.86	14.4	355
RS13	Redwing	715.5	30/19	1.081	13CD	2.4	1.09	15.6	396
RS12	Cuckoo	795.0	24/7	1.092	12CD	1.9	0.86	14.4	355
RS12	Drake	795.0	26/7	1.108	12CD	1.9	0.86	14.4	355
RS14	Mallard	795.0	30/19	1.140	14CD	3.1	1.41	16.8	427
RS11	Coot	795.0	36/1	1.040	11CD	1.5	0.68	13.2	335
RS12	Tern	795.0	45/7	1.063	12CD	1.9	0.86	14.4	355
RS12	Condor	795.0	54/7	1.093	12CD	1.9	0.86	14.4	355
RS12	Ruddy	900.0	45/7	1.131	12CD	1.9	0.86	14.4	355
RS13	Canary	900.0	54/7	1.162	13CD	2.4	1.09	15.6	396
RS12	Catbird	954.0	36/1	1.140	12CD	1.9	0.86	14.4	355
RS13	Rail	954.0	45/7	1.165	13CD	2.4	1.09	15.6	396
RS13	Cardinal	954.0	54/7	1.196	13CD	2.4	1.09	15.6	396
RS13	Tanger	1033.5	36/1	1.186	13CD	2.4	1.09	15.6	396
RS13	Ortolan	1033.5	45/7	1.212	13CD	2.4	1.09	15.6	396
RS14	Curlew	1033.5	54/7	1.244	14CD	3.1	1.41	16.8	427
RS14	Bluejay	1113.0	45/7	1.259	14CD	3.1	1.41	16.8	427
RS14	Finch	1113.0	54/19	1.293	14CD	3.1	1.41	16.8	427
RS14	Bunting	1192.5	45/7	1.302	14CD	3.1	1.41	16.8	427
RS15	Grackle	1192.5	54/19	1.333	15CD	3.8	1.72	18.0	457
RS15	Bittern	1272.0	45/7	1.345	15CD	3.8	1.72	18.0	457
RS15	Pheasant	1272.0	54/19	1.382	15CD	3.8	1.72	18.0	457
RS15	Dipper	1351.5	45/7	1.385	15CD	3.8	1.72	18.0	457
RS15	Martin	1351.5	54/19	1.424	15CD	3.8	1.72	18.0	457
RS16	Bobolink	1431.0	45/7	1.427	16CD	4.6	2.09	19.2	488
RS16	Plover	1431.0	54/19	1.465	16CD	4.6	2.09	19.2	488
RS16	Nuthatch	1510.5	45/7	1.466	16CD	4.6	2.09	19.2	488
RS16	Parrot	1510.5	54/19	1.506	16CD	4.6	2.09	19.2	488
RS16	Lapwing	1590.0	45/7	1.504	16CD	4.6	2.09	19.2	488
RS17	Falcon	1590.0	54/19	1.545	17CD	5.5	2.49	20.4	518
RS17	Chukar	1780.0	84/19	1.602	17CD	5.5	2.49	20.4	518
RS18	—	2034.0	72/7	1.681	18CD	6.6	2.99	21.6	549
RS19	Bluebird	2156.0	84/19	1.762	19CD	7.8	3.54	22.8	579
RS19	Kiwi	2167.0	72/7	1.737	19CD	7.8	3.54	22.8	579
RS19	Thrasher	2312.0	76/19	1.802	19CD	7.8	3.54	22.8	579
RS20	Joree	2515.0	76/19	1.880	20CD	9.1	4.13	24.0	610

Quick Compress Jumper Connector for ACSR Conductor, JC Series

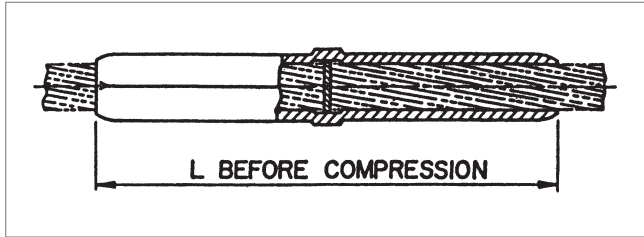

The Quick Compress Jumper Connector is designed for fast and easy installation. By using a high strength alloy, the compression length has been shortened for less compression bites. The jumper connector is pre-filled, eliminating an installation step. Each jumper connector has a center stop, making it easy to center the jumper on the conductor.

All Quick Compress Jumper Connectors are designed for limited tension use, maintaining a minimum of 40% of the ASTM rated strength of the conductor.

The end tapers of all compression accessories are supplied with a High Voltage finish for die size sections 12CD and above.

Ordering Instructions

Step 1: Assembly Catalog Number

Determine the assembly catalog number based on the conductor being used.

Example:

A jumper connector for 795 Drake conductor, the complete catalog number is:

JC12

Notes:

1. Installation Instructions for Jumpers are on page 271.
2. For more information on die selection and ordering instructions, see Tools and Equipment tab in this catalog.

CATALOG NUMBER	CONDUCTOR				DIE SIZE	TOTAL WEIGHT		DIMENSION L	
	CODE WORD	SIZE	STRANDING	DIAMETER		LBS	KG	IN	MM
		KCMIL	AL/ST	IN					
JC07	Owl	266.8	6/7	0.633	07CD	0.3	0.12	5.6	142
JC07	Waxwing	266.8	18/1	0.609	07CD	0.3	0.12	5.6	142
JC07	Partridge	266.8	26/7	0.642	07CD	0.3	0.12	5.6	142
JC08	Ostrich	300.0	26/7	0.680	08CD	0.4	0.19	6.4	163
JC08	Merlin	336.4	18/1	0.684	08CD	0.4	0.19	6.4	163
JC08	Linnet	336.4	26/7	0.720	08CD	0.4	0.19	6.4	163
JC09	Oriole	336.4	30/7	0.741	09CD	0.6	0.27	7.2	183
JC08	Chickadee	397.5	18/1	0.743	08CD	0.4	0.19	6.4	163
JC09	Brant	397.5	24/7	0.772	09CD	0.6	0.27	7.2	183
JC09	Ibis	397.5	26/7	0.783	09CD	0.6	0.27	7.2	183
JC10	Lark	397.5	30/7	0.806	10CD	0.8	0.37	8.0	203
JC09	Pelican	477.0	18/1	0.814	09CD	0.6	0.27	7.2	183
JC09	Flicker	477.0	24/7	0.846	09CD	0.6	0.27	7.2	183
JC10	Hawk	477.0	26/7	0.858	10CD	0.8	0.37	8.0	203
JC11	Hen	477.0	30/7	0.883	11CD	1.1	0.50	8.8	224
JC10	Osprey	556.5	18/1	0.879	10CD	0.8	0.37	8.0	203
JC10	Parakeet	556.5	24/7	0.914	10CD	0.8	0.37	8.0	203
JC10	Dove	556.5	26/7	0.927	10CD	0.8	0.37	8.0	203
JC11	Eagle	556.5	30/7	0.953	11CD	1.1	0.50	8.8	224
JC11	Peacock	605.0	24/7	0.953	11CD	1.1	0.50	8.8	224

Quick Compress Jumper Connector for ACSR Conductor, JC Series (cont.)

CATALOG NUMBER	CONDUCTOR				DIE SIZE	TOTAL WEIGHT		DIMENSION L	
	CODE WORD	SIZE	STRANDING	DIAMETER		LBS	KG	IN	MM
		KCMIL	AL/ST	IN					
JC11	Squab	605	26/7	0.966	11CD	1.1	0.50	8.8	224
JC12	Teal	605	30/19	0.994	12CD	1.4	0.64	9.6	244
JC10	Kingbird	636	18/1	0.940	10CD	0.8	0.37	8.0	203
JC11	Rook	636	24/7	0.977	11CD	1.1	0.50	8.8	224
JC11	Grosbeak	636	26/7	0.990	11CD	1.1	0.50	8.8	224
JC12	Egret	636	30/19	1.019	12CD	1.4	0.64	9.6	244
JC10	Swift	636	36/1	0.930	10CD	0.8	0.37	8.0	203
JC11	Flamingo	666.6	24/7	1.000	11CD	1.1	0.50	8.8	224
JC11	Stilt	715.5	24/7	1.036	11CD	1.1	0.50	8.8	224
JC12	Starling	715.5	26/7	1.051	12CD	1.4	0.64	9.6	244
JC13	Redwing	715.5	30/19	1.081	13CD	1.7	0.77	10.4	264
JC12	Cuckoo	795.0	24/7	1.092	12CD	1.4	0.64	9.6	244
JC12	Drake	795.0	26/7	1.108	12CD	1.4	0.64	9.6	244
JC14	Mallard	795.0	30/19	1.140	14CD	2.2	1.00	11.2	284
JC11	Coot	795.0	36/1	1.040	11CD	1.1	0.50	8.8	224
JC12	Tern	795.0	45/7	1.063	12CD	1.4	0.64	9.6	244
JC12	Condor	795.0	54/7	1.093	12CD	1.4	0.64	9.6	244
JC12	Ruddy	900.0	45/7	1.131	12CD	1.4	0.64	9.6	244
JC13	Canary	900.0	54/7	1.162	13CD	1.7	0.77	10.4	264
JC12	Catbird	954.0	36/1	1.14	12CD	1.4	0.64	9.6	244
JC13	Rail	954.0	45/7	1.165	13CD	1.7	0.77	10.4	264
JC13	Cardinal	954.0	54/7	1.196	13CD	1.7	0.77	10.4	264
JC13	Tanager	1033.5	36/1	1.186	13CD	1.7	0.77	10.4	264
JC13	Ortolan	1033.5	45/7	1.212	13CD	1.7	0.77	10.4	264
JC14	Curlew	1033.5	54/7	1.244	14CD	2.2	1.00	11.2	284
JC14	Bluejay	1113.0	45/7	1.259	14CD	2.2	1.00	11.2	284
JC14	Finch	1113.0	54/19	1.293	14CD	2.2	1.00	11.2	284
JC14	Bunting	1192.5	45/7	1.302	14CD	2.2	1.00	11.2	284
JC15	Grackle	1192.5	54/19	1.333	15CD	2.7	1.22	12.0	305
JC15	Bittern	1272.0	45/7	1.345	15CD	2.7	1.22	12.0	305
JC15	Pheasant	1272.0	54/19	1.382	15CD	2.7	1.22	12.0	305
JC15	Dipper	1351.5	45/7	1.385	15CD	2.7	1.22	12.0	305
JC15	Martin	1351.5	54/19	1.424	15CD	2.7	1.22	12.0	305
JC16	Bobolink	1431.0	45/7	1.427	16CD	3.3	1.50	12.8	325
JC16	Plover	1431.0	54/19	1.465	16CD	3.3	1.50	12.8	325
JC16	Nuthatch	1510.5	45/7	1.466	16CD	3.3	1.50	12.8	325
JC16	Parrot	1510.5	54/19	1.506	16CD	3.3	1.50	12.8	325
JC16	Lapwing	1590.0	45/7	1.504	16CD	3.3	1.50	12.8	325
JC17	Falcon	1590.0	54/19	1.545	17CD	3.9	1.77	13.6	345
JC17	Chukar	1780.0	84/19	1.602	17CD	3.9	1.77	13.6	345
JC18	—	2034.0	72/7	1.681	18CD	4.7	2.13	14.4	366
JC19	Bluebird	2156.0	84/19	1.762	19CD	5.4	2.45	15.2	386
JC19	Kiwi	2167.0	72/7	1.737	19CD	5.4	2.45	15.2	386
JC19	Thrasher	2312.0	76/19	1.802	19CD	5.4	2.45	15.2	386
JC20	Joree	2515.0	76/19	1.880	20CD	6.4	2.90	16.0	406

Quick Compress Terminal for ACSR Conductor, Straight, TS Series

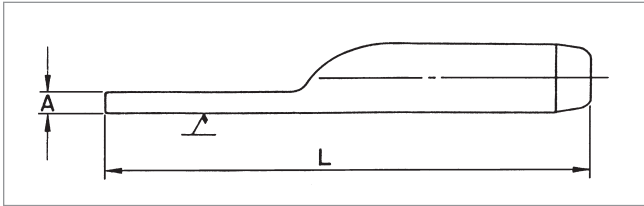

The TS Series Straight Terminal Connector is designed for fast and easy installation. By using a high strength alloy, the compression length has been shortened for less compression bites. The terminal connector is pre-filled, eliminating an installation step.

All TS Series connectors are designed for limited tension use, maintaining a minimum of 40% of the ASTM rated strength of the conductor.

The end tapers of all compression accessories are supplied with a High Voltage finish for die size sections 12CD and above.

The square edges of bolted pads of the compression accessories could cause Corona. Pads with edges and corners rounded can be supplied by adding the catalog suffix 'EHV'.

Ordering Instructions

Step 1: Catalog Number

Determine the catalog number based on the conductor being used.

Step 2: Extra High Voltage Finish

For Extra High Voltage Finish, use 'EHV'. (≥ 345 kV)

For Standard Finish, leave blank. (< 345 kV)

Step 3: Assemble Catalog Number.

Catalog Number	+	EHV Finish
-------------------	---	---------------

Example:

A straight terminal for 795 Drake with an EHV finish, the complete catalog number is:

TS12EHV

Notes:

1. Pad Dimensions are on page 257.
2. Installation Instructions for Terminals are on page 272.
3. Bolts, nuts and washers are not supplied with TS Series Terminal Connectors.
4. For more information on die selection and ordering instructions, see Tools and Equipment tab in this catalog.

Quick Compress Terminal for ACSR Conductor, Straight, TS Series (cont.)

CATALOG NUMBER	CONDUCTOR				DIE SIZE	TOTAL WEIGHT		DIMENSIONS				PAD SIZE
	CODE WORD	SIZE	STRANDING	DIAMETER		LBS	KG	A		L		
		KCMIL	AL/ST	IN				IN	MM	IN	MM	
TS07	Owl	266.8	6/7	0.633	07CD	0.5	0.20	0.3	8	9.0	229	B
TS07	Waxwing	266.8	18/1	0.609	07CD	0.5	0.20	0.3	8	9.0	229	B
TS07	Partridge	266.8	26/7	0.642	07CD	0.5	0.20	0.3	8	9.0	229	B
TS08	Ostrich	300.0	26/7	0.680	08CD	0.6	0.28	0.4	10	9.6	244	B
TS08	Merlin	336.4	18/1	0.684	08CD	0.6	0.28	0.4	10	9.6	244	B
TS08	Linnet	336.4	26/7	0.720	08CD	0.6	0.28	0.4	10	9.6	244	B
TS09	Oriole	336.4	30/7	0.741	09CD	0.8	0.38	0.4	11	10.0	254	B
TS08	Chickadee	397.5	18/1	0.743	08CD	0.6	0.28	0.4	10	9.6	244	B
TS09	Brant	397.5	24/7	0.772	09CD	0.8	0.38	0.4	11	10.0	254	B
TS09	Ibis	397.5	26/7	0.783	09CD	0.8	0.38	0.4	11	10.0	254	B
TS10	Lark	397.5	30/7	0.806	10CD	1.1	0.50	0.5	12	10.6	269	B
TS09	Pelican	477.0	18/1	0.814	09CD	0.8	0.38	0.4	11	10.0	254	B
TS09	Flicker	477.0	24/7	0.846	09CD	0.8	0.38	0.4	11	10.0	254	B
TS10	Hawk	477.0	26/7	0.858	10CD	1.1	0.50	0.5	12	10.6	269	B
TS11	Hen	477.0	30/7	0.883	11CD	1.5	0.68	0.4	9	11.7	297	D
TS10	Osprey	556.5	18/1	0.879	10CD	1.1	0.50	0.5	12	10.6	269	B
TS10	Parakeet	556.5	24/7	0.914	10CD	1.1	0.50	0.5	12	10.6	269	B
TS10	Dove	556.5	26/7	0.927	10CD	1.1	0.50	0.5	12	10.6	269	B
TS11	Eagle	556.5	30/7	0.953	11CD	1.5	0.68	0.4	9	11.7	297	D
TS11	Peacock	605.0	24/7	0.953	11CD	1.5	0.68	0.4	9	11.7	297	D
TS11	Squab	605.0	26/7	0.966	11CD	1.5	0.68	0.4	9	11.7	297	D
TS12	Teal	605.0	30/19	0.994	12CD	1.8	0.82	0.4	11	12.1	307	D
TS10	Kingbird	636.0	18/1	0.940	10CD	1.1	0.50	0.5	12	10.6	269	B
TS11	Rook	636.0	24/7	0.977	11CD	1.5	0.68	0.4	9	11.7	297	D
TS11	Grosbeak	636.0	26/7	0.990	11CD	1.5	0.68	0.4	9	11.7	297	D
TS12	Egret	636.0	30/19	1.019	12CD	1.8	0.82	0.4	11	12.1	307	D
TS10	Swift	636.0	36/1	0.930	10CD	1.1	0.50	0.5	12	10.6	269	B
TS11	Flamingo	666.6	24/7	1.000	11CD	1.5	0.68	0.4	9	11.7	297	D
TS11	Stilt	715.5	24/7	1.036	11CD	1.5	0.68	0.4	9	11.7	297	D
TS12	Starling	715.5	26/7	1.051	12CD	1.8	0.82	0.4	11	12.1	307	D
TS13	Redwing	715.5	30/19	1.081	13CD	2.1	0.95	0.5	13	12.8	325	D
TS12	Cuckoo	795.0	24/7	1.092	12CD	1.8	0.82	0.4	11	12.1	307	D
TS12	Drake	795.0	26/7	1.108	12CD	1.8	0.82	0.4	11	12.1	307	D
TS14	Mallard	795.0	30/19	1.140	14CD	2.7	1.22	0.6	16	13.8	351	D
TS11	Coot	795.0	36/1	1.040	11CD	1.5	0.68	0.4	9	11.7	297	D
TS12	Tern	795.0	45/7	1.063	12CD	1.8	0.82	0.4	11	12.1	307	D
TS12	Condor	795.0	54/7	1.093	12CD	1.8	0.82	0.4	11	12.1	307	D
TS12	Ruddy	900.0	45/7	1.131	12CD	1.8	0.82	0.4	11	12.1	307	D



Quick Compress Terminal for ACSR Conductor, Straight, TS Series (cont.)

CATALOG NUMBER	CONDUCTOR				DIE SIZE	TOTAL WEIGHT		DIMENSIONS				PAD SIZE
	CODE WORD	SIZE	STRANDING	DIAMETER		LBS	KG	A		L		
		KCMIL	AL/ST	IN				IN	MM	IN	MM	
TS13	Canary	900.0	54/7	1.162	13CD	2.1	0.95	0.5	13	12.8	325	D
TS12	Catbird	954.0	36/1	1.140	12CD	1.8	0.82	0.4	11	12.1	307	D
TS13	Rail	954.0	45/7	1.165	13CD	2.1	0.95	0.5	13	12.8	325	D
TS13	Cardinal	954.0	54/7	1.196	13CD	2.1	0.95	0.5	13	12.8	325	D
TS13	Tanger	1033.5	36/1	1.186	13CD	2.1	0.95	0.5	13	12.8	325	D
TS13	Ortolan	1033.5	45/7	1.212	13CD	2.1	0.95	0.5	13	12.8	325	D
TS14	Curlew	1033.5	54/7	1.244	14CD	2.7	1.22	0.6	16	13.8	351	D
TS14	Bluejay	1113.0	45/7	1.259	14CD	2.7	1.22	0.6	16	13.8	351	D
TS14	Finch	1113.0	54/19	1.293	14CD	2.7	1.22	0.6	16	13.8	351	D
TS14	Bunting	1192.5	45/7	1.302	14CD	2.7	1.22	0.6	16	13.8	351	D
TS15	Grackle	1192.5	54/19	1.333	15CD	3.3	1.50	0.7	17	14.3	363	D
TS15	Bittern	1272.0	45/7	1.345	15CD	3.3	1.50	0.7	17	14.3	363	D
TS15	Pheasant	1272.0	54/19	1.382	15CD	3.3	1.50	0.7	17	14.3	363	D
TS15	Dipper	1351.5	45/7	1.385	15CD	3.3	1.50	0.7	17	14.3	363	D
TS15	Martin	1351.5	54/19	1.424	15CD	3.3	1.50	0.7	17	14.3	363	D
TS16	Bobolink	1431.0	45/7	1.427	16CD	3.8	1.72	0.7	17	14.6	371	D
TS16	Plover	1431.0	54/19	1.465	16CD	3.8	1.72	0.7	17	14.6	371	D
TS16	Nuthatch	1510.5	45/7	1.466	16CD	3.8	1.72	0.7	17	14.6	371	D
TS16	Parrot	1510.5	54/19	1.506	16CD	3.8	1.72	0.7	17	14.6	371	D
TS16	Lapwing	1590.0	45/7	1.504	16CD	3.8	1.72	0.7	17	14.6	371	D
TS17	Falcon	1590.0	54/19	1.545	17CD	4.7	2.13	0.7	17	16.3	414	E
TS17	Chukar	1780.0	84/19	1.602	17CD	4.7	2.13	0.7	17	16.3	414	E
TS18	—	2034.0	72/7	1.681	18CD	5.5	2.49	0.7	19	16.8	427	E
TS19	Bluebird	2156.0	84/19	1.762	19CD	6.5	2.95	0.9	22	17.5	445	E
TS19	Kiwi	2167.0	72/7	1.737	19CD	6.5	2.95	0.9	22	17.5	445	E
TS19	Thrasher	2312.0	76/19	1.802	19CD	6.5	2.95	0.9	22	17.5	445	E
TS20	Joree	2515.0	76/19	1.880	20CD	7.3	3.31	0.9	22	17.9	455	E

Quick Compress Terminal for ACSR Conductor, 15°, TF Series

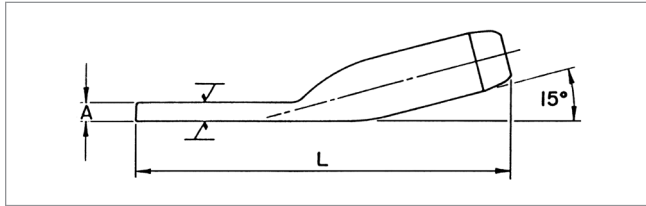

The TF Series 15° Terminal Connector is designed for fast and easy installation. By using a high strength alloy, the compression length has been shortened for less compression bites. The terminal connector is pre-filled, eliminating an installation step.

When used with the Quick Compress dead end, the TF Series connectors can be bolted in either straight or 30° position. All TF Series connectors are designed for limited tension use, maintaining a minimum of 40% of the ASTM rated strength of the conductor.

The end tapers of all compression accessories are supplied with a High Voltage finish for die size sections 12CD and above.

The square edges of bolted pads of the compression accessories could cause Corona. Pads with edges and corners rounded can be supplied by adding the catalog suffix 'EHV'.

Ordering Instructions

Step 1: Catalog Number

Determine the catalog number based on the conductor being used.

Step 2: Extra High Voltage Finish

For Extra High Voltage Finish, use 'EHV'. (≥ 345 kV)

For Standard Finish, leave blank. (< 345 kV)

Step 3: Assemble Catalog Number.



Example:

A 15° terminal for 795 Drake with an EHV finish, the complete catalog number is:

TF12EHV

Notes:

1. Pad Dimensions are on page 257.
2. Installation Instructions for Terminals are on page 272.
3. Bolts, nuts and washers are supplied with TF Series Terminal Connectors.
4. For more information on die selection and ordering instructions, see Tools and Equipment tab in this catalog.

Quick Compress Terminal for ACSR Conductor, 15°, TF Series (cont.)

CATALOG NUMBER	CONDUCTOR				DIE SIZE	TOTAL WEIGHT		DIMENSIONS				PAD SIZE
	CODE WORD	SIZE	STRANDING	DIAMETER		LBS	KG	A		L		
		KCMIL	AL/ST	IN				IN	MM	IN	MM	
TF07	Owl	266.8	6/7	0.633	07CD	0.5	0.24	0.3	8	7.8	196	B
TF07	Waxwing	266.8	18/1	0.609	07CD	0.5	0.24	0.3	8	7.8	196	B
TF07	Partridge	266.8	26/7	0.642	07CD	0.5	0.24	0.3	8	7.8	196	B
TF08	Ostrich	300	26/7	0.680	08CD	0.7	0.31	0.4	10	8.3	211	B
TF08	Merlin	336.4	18/1	0.684	08CD	0.7	0.31	0.4	10	8.3	211	B
TF08	Linnet	336.4	26/7	0.720	08CD	0.7	0.31	0.4	10	8.3	211	B
TF09	Oriole	336.4	30/7	0.741	09CD	0.9	0.40	0.4	11	8.9	226	B
TF08	Chickadee	397.5	18/1	0.743	08CD	0.7	0.31	0.4	10	8.3	211	B
TF09	Brant	397.5	24/7	0.772	09CD	0.9	0.40	0.4	11	8.9	226	B
TF09	Ibis	397.5	26/7	0.783	09CD	0.9	0.40	0.4	11	8.9	226	B
TF10	Lark	397.5	30/7	0.806	10CD	1.1	0.50	0.5	12	9.4	239	B
TF09	Pelican	477	18/1	0.814	09CD	0.9	0.40	0.4	11	8.9	226	B
TF09	Flicker	477	24/7	0.846	09CD	0.9	0.40	0.4	11	8.9	226	B
TF10	Hawk	477	26/7	0.858	10CD	1.1	0.50	0.5	12	9.4	239	B
TF11	Hen	477	30/7	0.883	11CD	1.5	0.68	0.4	9	10.4	264	D
TF10	Osprey	556.5	18/1	0.879	10CD	1.1	0.50	0.5	12	9.4	239	B
TF10	Parakeet	556.5	24/7	0.914	10CD	1.1	0.50	0.5	12	9.4	239	B
TF10	Dove	556.5	26/7	0.927	10CD	1.1	0.50	0.5	12	9.4	239	B
TF11	Eagle	556.5	30/7	0.953	11CD	1.5	0.68	0.4	9	10.4	264	D
TF11	Peacock	605	24/7	0.953	11CD	1.5	0.68	0.4	9	10.4	264	D
TF11	Squab	605	26/7	0.966	11CD	1.5	0.68	0.4	9	10.4	264	D
TF12	Teal	605	30/19	0.994	12CD	1.9	0.86	0.4	11	11.0	279	D
TF10	Kingbird	636	18/1	0.940	10CD	1.1	0.50	0.5	12	9.4	239	B
TF11	Rook	636	24/7	0.977	11CD	1.5	0.68	0.4	9	10.4	264	D
TF11	Grosbeak	636	26/7	0.990	11CD	1.5	0.68	0.4	9	10.4	264	D
TF12	Egret	636	30/19	1.019	12CD	1.9	0.86	0.4	11	11.0	279	D
TF10	Swift	636	36/1	0.930	10CD	1.1	0.50	0.5	12	9.4	239	B
TF11	Flamingo	666.6	24/7	1.000	11CD	1.5	0.68	0.4	9	10.4	264	D
TF11	Stilt	715.5	24/7	1.036	11CD	1.5	0.68	0.4	9	10.4	264	D
TF12	Starling	715.5	26/7	1.051	12CD	1.9	0.86	0.4	11	11.0	279	D
TF13	Redwing	715.5	30/19	1.081	13CD	2.2	1.00	0.5	13	11.2	284	D
TF12	Cuckoo	795	24/7	1.092	12CD	1.9	0.86	0.4	11	11.0	279	D
TF12	Drake	795	26/7	1.108	12CD	1.9	0.86	0.4	11	11.0	279	D
TF14	Mallard	795	30/19	1.140	14CD	2.8	1.27	0.6	16	12.0	305	D
TF11	Coot	795	36/1	1.040	11CD	1.5	0.68	0.4	9	10.4	264	D
TF12	Tern	795	45/7	1.063	12CD	1.9	0.86	0.4	11	11.0	279	D

Quick Compress Terminal for ACSR Conductor, 15°, TF Series (cont.)

CATALOG NUMBER	CONDUCTOR				DIE SIZE	TOTAL WEIGHT		DIMENSIONS				PAD SIZE
	CODE WORD	SIZE	STRANDING	DIAMETER		LBS	KG	A		L		
		KCMIL	AL/ST	IN				IN	MM	IN	MM	
TF12	Condor	795	54/7	1.093	12CD	1.9	0.86	0.4	11	11.0	279	D
TF12	Ruddy	900	45/7	1.131	12CD	1.9	0.86	0.4	11	11.0	279	D
TF13	Canary	900	54/7	1.162	13CD	2.2	1.00	0.5	13	11.2	284	D
TF12	Catbird	954	36/1	1.140	12CD	1.9	0.86	0.4	11	11.0	279	D
TF13	Rail	954	45/7	1.165	13CD	2.2	1.00	0.5	13	11.2	284	D
TF13	Cardinal	954	54/7	1.196	13CD	2.2	1.00	0.5	13	11.2	284	D
TF13	Tanger	1033.5	36/1	1.186	13CD	2.2	1.00	0.5	13	11.2	284	D
TF13	Ortolan	1033.5	45/7	1.212	13CD	2.2	1.00	0.5	13	11.2	284	D
TF14	Curlew	1033.5	54/7	1.244	14CD	2.8	1.27	0.6	16	12.0	305	D
TF14	Bluejay	1113	45/7	1.259	14CD	2.8	1.27	0.6	16	12.0	305	D
TF14	Finch	1113	54/19	1.293	14CD	2.8	1.27	0.6	16	12.0	305	D
TF14	Bunting	1192.5	45/7	1.302	14CD	2.8	1.27	0.6	16	12.0	305	D
TF15	Grackle	1192.5	54/19	1.333	15CD	3.2	1.45	0.7	17	12.5	318	D
TF15	Bittern	1272	45/7	1.345	15CD	3.2	1.45	0.7	17	12.5	318	D
TF15	Pheasant	1272	54/19	1.382	15CD	3.2	1.45	0.7	17	12.5	318	D
TF15	Dipper	1351.5	45/7	1.385	15CD	3.2	1.45	0.7	17	12.5	318	D
TF15	Martin	1351.5	54/19	1.424	15CD	3.2	1.45	0.7	17	12.5	318	D
TF16	Bobolink	1431	45/7	1.427	16CD	3.7	1.69	0.7	17	13.3	338	D
TF16	Plover	1431	54/19	1.465	16CD	3.7	1.69	0.7	17	13.3	338	D
TF16	Nuthatch	1510.5	45/7	1.466	16CD	3.7	1.69	0.7	17	13.3	338	D
TF16	Parrot	1510.5	54/19	1.506	16CD	3.7	1.69	0.7	17	13.3	338	D
TF16	Lapwing	1590	45/7	1.504	16CD	3.7	1.69	0.7	17	13.3	338	D
TF17	Falcon	1590	54/19	1.545	17CD	4.6	2.09	0.7	17	14.4	366	E
TF17	Chukar	1780	84/19	1.602	17CD	4.6	2.09	0.7	17	14.4	366	E
TF18	—	2034	72/7	1.681	18CD	5.2	2.36	0.7	19	15.0	381	E
TF19	Bluebird	2156	84/19	1.762	19CD	6.3	2.86	0.9	22	15.7	399	E
TF19	Kiwi	2167	72/7	1.737	19CD	6.3	2.86	0.9	22	15.7	399	E
TF19	Thrasher	2312	74/19	1.802	19CD	6.3	2.86	0.9	22	15.7	399	E
TF20	Joree	2515	74/19	1.880	20CD	6.8	3.08	0.9	22	16.0	406	E

Quick Compress Terminal for ACSR Conductor, 45°, T45 Series

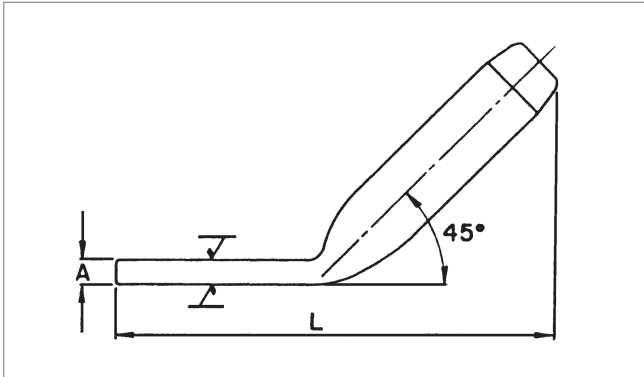

The T45 Series 45° Terminal Connector is designed for fast and easy installation. By using a high strength alloy, the compression length has been shortened for less compression bites. The terminal connector is pre-filled, eliminating an installation step.

All T45 Series connectors are designed for limited tension use, maintaining a minimum of 40% of the ASTM rated strength of the conductor.

The end tapers of all compression accessories are supplied with a High Voltage finish for die size sections 12CD and above.

The square edges of bolted pads of the compression accessories could cause Corona. Pads with edges and corners rounded can be supplied by adding the catalog suffix 'EHV'.

Ordering Instructions

Step 1: Catalog Number

Determine the catalog number based on the conductor being used.

Step 2: Extra High Voltage Finish

For Extra High Voltage Finish, use 'EHV'. (≥ 345 kV)

For Standard Finish, leave blank. (< 345 kV)

Step 3: Assemble Catalog Number.



Example:

A 45° terminal for 795 Drake with an EHV finish, the complete catalog number is:

T4512EHV

Notes:

1. Pad Dimensions are on page 257.
2. Installation Instructions for Terminals are on page 272.
3. Bolts, nuts and washers are not supplied with T45 Series Terminal Connectors.
4. For more information on die selection and ordering instructions, see Tools and Equipment tab in this catalog.

Quick Compress Terminal for ACSR Conductor, 45°, T45 Series (cont.)

CATALOG NUMBER	CONDUCTOR				DIE SIZE	TOTAL WEIGHT		DIMENSIONS				PAD SIZE
	CODE WORD	SIZE	STRANDING	DIAMETER		LBS	KG	A		L		
		KCMIL	AL/ST	IN				IN	MM	IN	MM	
T4507	Owl	266.8	6/7	0.633	07CD	0.4	0.19	0.3	8	7.3	185	B
T4507	Waxwing	266.8	18/1	0.609	07CD	0.4	0.19	0.3	8	7.3	185	B
T4507	Partridge	266.8	26/7	0.642	07CD	0.4	0.19	0.3	8	7.3	185	B
T4508	Ostrich	300.0	26/7	0.680	08CD	0.6	0.25	0.4	10	7.8	198	B
T4508	Merlin	336.4	18/1	0.684	08CD	0.6	0.25	0.4	10	7.8	198	B
T4508	Linnet	336.4	26/7	0.720	08CD	0.6	0.25	0.4	10	7.8	198	B
T4509	Oriole	336.4	30/7	0.741	09CD	0.8	0.34	0.4	11	8.2	208	B
T4508	Chickadee	397.5	18/1	0.743	08CD	0.6	0.25	0.4	10	7.8	198	B
T4509	Brant	397.5	24/7	0.772	09CD	0.8	0.34	0.4	11	8.2	208	B
T4509	Ibis	397.5	26/7	0.783	09CD	0.8	0.34	0.4	11	8.2	208	B
T4510	Lark	397.5	30/7	0.806	10CD	1.0	0.45	0.5	12	8.6	218	B
T4509	Pelican	477.0	18/1	0.814	09CD	0.8	0.34	0.4	11	8.2	208	B
T4509	Flicker	477.0	24/7	0.846	09CD	0.8	0.34	0.4	11	8.2	208	B
T4510	Hawk	477.0	26/7	0.858	10CD	1.0	0.45	0.5	12	8.6	218	B
T4511	Hen	477.0	30/7	0.883	11CD	1.3	0.59	0.4	9	9.4	239	D
T4510	Osprey	556.5	18/1	0.879	10CD	1.0	0.45	0.5	12	8.6	218	B
T4510	Parakeet	556.5	24/7	0.914	10CD	1.0	0.45	0.5	12	8.6	218	B
T4510	Dove	556.5	26/7	0.927	10CD	1.0	0.45	0.5	12	8.6	218	B
T4511	Eagle	556.5	30/7	0.953	11CD	1.3	0.59	0.4	9	9.4	239	D
T4511	Peacock	605.0	24/7	0.953	11CD	1.3	0.59	0.4	9	9.4	239	D
T4511	Squab	605.0	26/7	0.966	11CD	1.3	0.59	0.4	9	9.4	239	D
T4512	Teal	605.0	30/19	0.994	12CD	1.6	0.73	0.4	11	9.7	246	D
T4510	Kingbird	636.0	18/1	0.940	10CD	1.0	0.45	0.5	12	8.6	218	B
T4511	Rook	636.0	24/7	0.977	11CD	1.3	0.59	0.4	9	9.4	239	D
T4511	Grosbeak	636.0	26/7	0.990	11CD	1.3	0.59	0.4	9	9.4	239	D
T4512	Egret	636.0	30/19	1.019	12CD	1.6	0.73	0.4	11	9.7	246	D
T4510	Swift	636.0	36/1	0.930	10CD	1.0	0.45	0.5	12	8.6	218	B
T4511	Flamingo	666.6	24/7	1.000	11CD	1.3	0.59	0.4	9	9.4	239	D
T4511	Stilt	715.5	24/7	1.036	11CD	1.3	0.59	0.4	9	9.4	239	D
T4512	Starling	715.5	26/7	1.051	12CD	1.6	0.73	0.4	11	9.7	246	D
T4513	Redwing	715.5	30/19	1.081	13CD	2.0	0.91	0.5	13	10.2	259	D
T4512	Cuckoo	795.0	24/7	1.092	12CD	1.6	0.73	0.4	11	9.7	246	D
T4512	Drake	795.0	26/7	1.108	12CD	1.6	0.73	0.4	11	9.7	246	D
T4514	Mallard	795.0	30/19	1.140	14CD	2.3	1.04	0.6	16	10.6	269	D
T4511	Coot	795.0	36/1	1.040	11CD	1.3	0.59	0.4	9	9.4	239	D
T4512	Tern	795.0	45/7	1.063	12CD	1.6	0.73	0.4	11	9.7	246	D
T4512	Condor	795.0	54/7	1.093	12CD	1.6	0.73	0.4	11	9.7	246	D
T4512	Ruddy	900.0	45/7	1.131	12CD	1.6	0.73	0.4	11	9.7	246	D

Quick Compress Terminal for ACSR Conductor, 45°, T45 Series (cont.)

CATALOG NUMBER	CONDUCTOR				DIE SIZE	TOTAL WEIGHT		DIMENSIONS				PAD SIZE
	CODE WORD	SIZE	STRANDING	DIAMETER		LBS	KG	A		L		
		KCMIL	AL/ST	IN				IN	MM	IN	MM	
T4513	Canary	900.0	54/7	1.162	13CD	2.0	0.91	0.5	13	10.2	259	D
T4512	Catbird	954.0	36/1	1.140	12CD	1.6	0.73	0.4	11	9.7	246	D
T4513	Rail	954.0	45/7	1.165	13CD	2.0	0.91	0.5	13	10.2	259	D
T4513	Cardinal	954.0	54/7	1.196	13CD	2.0	0.91	0.5	13	10.2	259	D
T4513	Tanger	1033.5	36/1	1.186	13CD	2.0	0.91	0.5	13	10.2	259	D
T4513	Ortolan	1033.5	45/7	1.212	13CD	2.0	0.91	0.5	13	10.2	259	D
T4514	Curlew	1033.5	54/7	1.244	14CD	2.3	1.04	0.6	16	10.6	269	D
T4514	Bluejay	1113.0	45/7	1.259	14CD	2.3	1.04	0.6	16	10.6	269	D
T4514	Finch	1113.0	54/19	1.293	14CD	2.3	1.04	0.6	16	10.6	269	D
T4514	Bunting	1192.5	45/7	1.302	14CD	2.3	1.04	0.6	16	10.6	269	D
T4515	Grackle	1192.5	54/19	1.333	15CD	2.8	1.27	0.7	17	11.8	300	D
T4515	Bittern	1272.0	45/7	1.345	15CD	2.8	1.27	0.7	17	11.8	300	D
T4515	Pheasant	1272.0	54/19	1.382	15CD	2.8	1.27	0.7	17	11.8	300	D
T4515	Dipper	1351.5	45/7	1.385	15CD	2.8	1.27	0.7	17	11.8	300	D
T4515	Martin	1351.5	54/19	1.424	15CD	2.8	1.27	0.7	17	11.8	300	D
T4516	Bobolink	1431.0	45/7	1.427	16CD	3.4	1.54	0.7	17	11.0	279	D
T4516	Plover	1431.0	54/19	1.465	16CD	3.4	1.54	0.7	17	11.0	279	D
T4516	Nuthatch	1510.5	45/7	1.466	16CD	3.4	1.54	0.7	17	11.0	279	D
T4516	Parrot	1510.5	54/19	1.506	16CD	3.4	1.54	0.7	17	11.0	279	D
T4516	Lapwing	1590.0	45/7	1.504	16CD	3.4	1.54	0.7	17	11.0	279	D
T4517	Falcon	1590.0	54/19	1.545	17CD	4.2	1.91	0.7	17	12.6	320	E
T4517	Chukar	1780.0	84/19	1.602	17CD	4.2	1.91	0.7	17	12.6	320	E
T4518	—	2034.0	72/7	1.681	18CD	4.9	2.22	0.7	19	13.0	330	E
T4519	Bluebird	2156.0	84/19	1.762	19CD	5.7	2.59	0.9	22	13.7	348	E
T4519	Kiwi	2167.0	72/7	1.737	19CD	5.7	2.59	0.9	22	13.7	348	E
T4519	Thrasher	2312.0	76/19	1.802	19CD	5.7	2.59	0.9	22	13.7	348	E
T4520	Joree	2515.0	76/19	1.880	20CD	6.5	2.95	0.9	22	14.2	361	E

Quick Compress Terminal for ACSR Conductor, 90°, TN Series

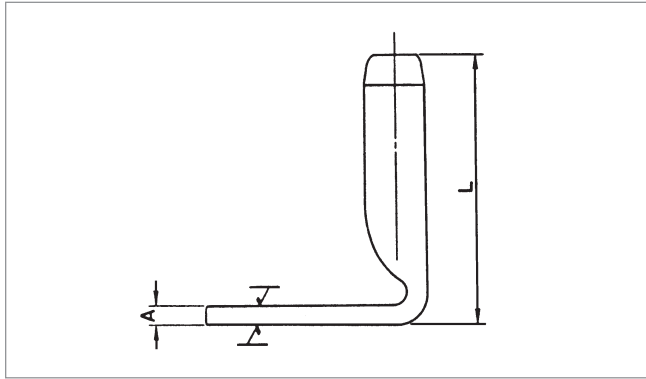

The TN Series 90° Terminal Connector is designed for fast and easy installation. By using a high strength alloy, the compression length has been shortened for less compression bites. The terminal connector is pre-filled, eliminating an installation step.

All TN Series connectors are designed for limited tension use, maintaining a minimum of 40% of the ASTM rated strength of the conductor.

The end tapers of all compression accessories are supplied with a High Voltage finish for die size sections 12CD and above.

The square edges of bolted pads of the compression accessories could cause Corona. Pads with edges and corners rounded can be supplied by adding the catalog suffix 'EHV'.

Ordering Instructions

Step 1: Catalog Number

Determine the catalog number based on the conductor being used.

Step 2: Extra High Voltage Finish

For Extra High Voltage Finish, use 'EHV'. (≥ 345 kV)

For Standard Finish, leave blank. (< 345 kV)

Step 3: Assemble Catalog Number.



Example:

A 90° terminal for 795 Drake with an EHV finish, the complete catalog number is:

TN12EHV

Notes:

1. Pad Dimensions are on page 257.
2. Installation Instructions for Terminals are on page 272.
3. Bolts, nuts and washers are not supplied with TN Series Terminal Connectors.
4. For more information on die selection and ordering instructions, see Tools and Equipment tab in this catalog.

Quick Compress Terminal for ACSR Conductor, 90°, TN Series (cont.)

CATALOG NUMBER	CONDUCTOR				DIE SIZE	TOTAL WEIGHT		DIMENSIONS				PAD SIZE
	CODE WORD	SIZE	STRANDING	DIAMETER		LBS	KG	A		L		
		KCMIL	AL/ST	IN				IN	MM	IN	MM	
TN07	Owl	266.8	6/7	0.633	07CD	0.5	0.20	0.3	8	5.2	132	B
TN07	Waxwing	266.8	18/1	0.609	07CD	0.5	0.20	0.3	8	5.2	132	B
TN07	Partridge	266.8	26/7	0.642	07CD	0.5	0.20	0.3	8	5.2	132	B
TN08	Ostrich	300.0	26/7	0.680	08CD	0.6	0.29	0.4	10	5.7	145	B
TN08	Merlin	336.4	18/1	0.684	08CD	0.6	0.29	0.4	10	5.7	145	B
TN08	Linnet	336.4	26/7	0.720	08CD	0.6	0.29	0.4	10	5.7	145	B
TN09	Oriole	336.4	30/7	0.741	09CD	0.8	0.38	0.4	11	6.2	157	B
TN08	Chickadee	397.5	18/1	0.743	08CD	0.6	0.29	0.4	10	5.7	145	B
TN09	Brant	397.5	24/7	0.772	09CD	0.8	0.38	0.4	11	6.2	157	B
TN09	Ibis	397.5	26/7	0.783	09CD	0.8	0.38	0.4	11	6.2	157	B
TN10	Lark	397.5	30/7	0.806	10CD	1.1	0.50	0.5	12	6.7	170	B
TN09	Pelican	477.0	18/1	0.814	09CD	0.8	0.38	0.4	11	6.2	157	B
TN09	Flicker	477.0	24/7	0.846	09CD	0.8	0.38	0.4	11	6.2	157	B
TN10	Hawk	477.0	26/7	0.858	10CD	1.1	0.50	0.5	12	6.7	170	B
TN11	Hen	477.0	30/7	0.883	11CD	1.4	0.64	0.4	9	7.5	191	D
TN10	Osprey	556.5	18/1	0.879	10CD	1.1	0.50	0.5	12	6.7	170	B
TN10	Parakeet	556.5	24/7	0.914	10CD	1.1	0.50	0.5	12	6.7	170	B
TN10	Dove	556.5	26/7	0.927	10CD	1.1	0.50	0.5	12	6.7	170	B
TN11	Eagle	556.5	30/7	0.953	11CD	1.4	0.64	0.4	9	7.5	191	D
TN11	Peacock	605.0	24/7	0.953	11CD	1.4	0.64	0.4	9	7.5	191	D
TN11	Squab	605.0	26/7	0.966	11CD	1.4	0.64	0.4	9	7.5	191	D
TN12	Teal	605.0	30/19	0.994	12CD	1.8	0.82	0.4	11	7.9	202	D
TN10	Kingbird	636.0	18/1	0.940	10CD	1.1	0.50	0.5	12	6.7	170	B
TN11	Rook	636.0	24/7	0.977	11CD	1.4	0.64	0.4	9	7.5	191	D
TN11	Grosbeak	636.0	26/7	0.990	11CD	1.4	0.64	0.4	9	7.5	191	D
TN12	Egret	636.0	30/19	1.019	12CD	1.8	0.82	0.4	11	7.9	202	D
TN10	Swift	636.0	36/1	0.930	10CD	1.1	0.50	0.5	12	6.7	170	B
TN11	Flamingo	666.6	24/7	1.000	11CD	1.4	0.64	0.4	9	7.5	191	D
TN11	Stilt	715.5	24/7	1.036	11CD	1.4	0.64	0.4	9	7.5	191	D
TN12	Starling	715.5	26/7	1.051	12CD	1.8	0.82	0.4	11	7.9	202	D
TN13	Redwing	715.5	30/19	1.081	13CD	2.2	1.00	0.5	13	8.5	216	D
TN12	Cuckoo	795.0	24/7	1.092	12CD	1.8	0.82	0.4	11	7.9	202	D
TN12	Drake	795.0	26/7	1.108	12CD	1.8	0.82	0.4	11	7.9	202	D
TN14	Mallard	795.0	30/19	1.140	14CD	2.6	1.18	0.6	16	9.2	233	D
TN11	Coot	795.0	36/1	1.040	11CD	1.4	0.64	0.4	9	7.5	191	D
TN12	Tern	795.0	45/7	1.063	12CD	1.8	0.82	0.4	11	7.9	202	D
TN12	Condor	795.0	54/7	1.093	12CD	1.8	0.82	0.4	11	7.9	202	D
TN12	Ruddy	900.0	45/7	1.131	12CD	1.8	0.82	0.4	11	7.9	202	D

Quick Compress Terminal for ACSR Conductor, 90°, TN Series (cont.)

CATALOG NUMBER	CONDUCTOR				DIE SIZE	TOTAL WEIGHT		DIMENSIONS				PAD SIZE
	CODE WORD	SIZE	STRANDING	DIAMETER		LBS	KG	A		L		
		KCMIL	AL/ST	IN				IN	MM	IN	MM	
TN13	Canary	900.0	54/7	1.162	13CD	2.2	1.00	0.5	13	8.5	216	D
TN12	Catbird	954.0	36/1	1.140	12CD	1.8	0.82	0.4	11	7.9	202	D
TN13	Rail	954.0	45/7	1.165	13CD	2.2	1.00	0.5	13	8.5	216	D
TN13	Cardinal	954.0	54/7	1.196	13CD	2.2	1.00	0.5	13	8.5	216	D
TN13	Tanger	1033.5	36/1	1.186	13CD	2.2	1.00	0.5	13	8.5	216	D
TN13	Ortolan	1033.5	45/7	1.212	13CD	2.2	1.00	0.5	13	8.5	216	D
TN14	Curlew	1033.5	54/7	1.244	14CD	2.6	1.18	0.6	16	9.2	233	D
TN14	Bluejay	1113.0	45/7	1.259	14CD	2.6	1.18	0.6	16	9.2	233	D
TN14	Finch	1113.0	54/19	1.293	14CD	2.6	1.18	0.6	16	9.2	233	D
TN14	Bunting	1192.5	45/7	1.302	14CD	2.6	1.18	0.6	16	9.2	233	D
TN15	Grackle	1192.5	54/19	1.333	15CD	3.1	1.41	0.7	17	9.8	248	D
TN15	Bittern	1272.0	45/7	1.345	15CD	3.1	1.41	0.7	17	9.8	248	D
TN15	Pheasant	1272.0	54/19	1.382	15CD	3.1	1.41	0.7	17	9.8	248	D
TN15	Dipper	1351.5	45/7	1.385	15CD	3.1	1.41	0.7	17	9.8	248	D
TN15	Martin	1351.5	54/19	1.424	15CD	3.1	1.41	0.7	17	9.8	248	D
TN16	Bobolink	1431.0	45/7	1.427	16CD	3.7	1.68	0.7	17	10.2	259	D
TN16	Plover	1431.0	54/19	1.465	16CD	3.7	1.68	0.7	17	10.2	259	D
TN16	Nuthatch	1510.5	45/7	1.466	16CD	3.7	1.68	0.7	17	10.2	259	D
TN16	Parrot	1510.5	54/19	1.506	16CD	3.7	1.68	0.7	17	10.2	259	D
TN16	Lapwing	1590.0	45/7	1.504	16CD	3.7	1.68	0.7	17	10.2	259	D
TN17	Falcon	1590.0	54/19	1.545	17CD	4.6	2.09	0.7	17	11.2	264	E
TN17	Chukar	1780.0	84/19	1.602	17CD	4.6	2.09	0.7	17	11.2	264	E
TN18	—	2034.0	72/7	1.681	18CD	5.3	2.40	0.7	19	11.4	289	E
TN19	Bluebird	2156.0	84/19	1.762	19CD	6.1	2.77	0.9	22	11.9	303	E
TN19	Kiwi	2167.0	72/7	1.737	19CD	6.1	2.77	0.9	22	11.9	303	E
TN19	Thrasher	2312.0	76/19	1.802	19CD	6.1	2.77	0.9	22	11.9	303	E
TN20	Joree	2515.0	76/19	1.880	20CD	6.9	3.13	0.9	22	12.6	321	E

Quick Compress Tee Connector for ACSR Conductor, Open Run, TTOC Series

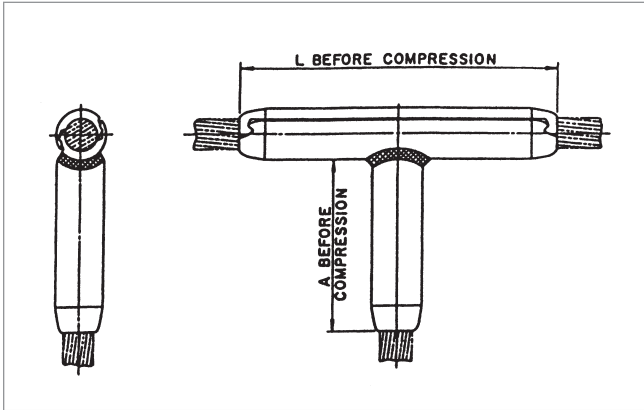

The TTOC Series Open Run Tee Connector is a permanent drop specifically designed for ACSR, AAC, AAAC and ACAR conductors.

The end tapers of all compression accessories are supplied with a high voltage finish for die size sections 12CD and above.

Ordering Instructions

Step 1: Assembly Catalog Number

Determine the assembly catalog number based on the conductor being used.

Example:

A tee connector for 795 Drake, the complete catalog number is:

TTOC12

Notes:

1. Tee Connectors are not prefilled with AFC.
2. Installation Instructions for Tee Connectors are on page 274.
3. For more information on die selection and ordering instructions, see Tools and Equipment tab in this catalog.

CATALOG NUMBER	CONDUCTOR				DIE SIZE	TOTAL WEIGHT		DIMENSIONS			
	CODE WORD	SIZE	STRANDING	DIAMETER		LBS	KG	A		L	
		KCMIL	AL/ST	IN				IN	MM	IN	MM
TTOC07	Owl	266.8	6/7	0.633	07CD	0.5	0.22	3.9	100	6.4	163
TTOC07	Waxwing	266.8	18/1	0.609	07CD	0.5	0.22	3.9	100	6.4	163
TTOC07	Partridge	266.8	26/7	0.642	07CD	0.5	0.22	3.9	100	6.4	163
TTOC08	Ostrich	300.0	26/7	0.680	08CD	0.7	0.32	4.4	111	7.2	183
TTOC08	Merlin	336.4	18/1	0.684	08CD	0.7	0.32	4.4	111	7.2	183
TTOC08	Linnet	336.4	26/7	0.720	08CD	0.7	0.32	4.4	111	7.2	183
TTOC09	Oriole	336.4	30/7	0.741	09CD	1.0	0.45	4.8	122	7.9	199
TTOC08	Chickadee	397.5	18/1	0.743	08CD	0.7	0.32	4.4	111	7.2	183
TTOC09	Brant	397.5	24/7	0.772	09CD	1.0	0.45	4.8	122	7.9	199
TTOC09	Ibis	397.5	26/7	0.783	09CD	1.0	0.45	4.8	122	7.9	199
TTOC10	Lark	397.5	30/7	0.806	10CD	1.3	0.59	5.3	133	8.5	216
TTOC09	Pelican	477.0	18/1	0.814	09CD	1.0	0.45	4.8	122	7.9	199
TTOC09	Flicker	477.0	24/7	0.846	09CD	1.0	0.45	4.8	122	7.9	199
TTOC10	Hawk	477.0	26/7	0.858	10CD	1.3	0.59	5.3	133	8.5	216
TTOC11	Hen	477.0	30/7	0.883	11CD	1.7	0.77	5.7	145	9.2	234
TTOC10	Osprey	556.5	18/1	0.879	10CD	1.3	0.59	5.3	133	8.5	216
TTOC10	Parakeet	556.5	24/7	0.914	10CD	1.3	0.59	5.3	133	8.5	216
TTOC10	Dove	556.5	26/7	0.927	10CD	1.3	0.59	5.3	133	8.5	216
TTOC11	Eagle	556.5	30/7	0.953	11CD	1.7	0.77	5.7	145	9.2	234
TTOC11	Peacock	605.0	24/7	0.953	11CD	1.7	0.77	5.7	145	9.2	234
TTOC11	Squab	605.0	26/7	0.966	11CD	1.7	0.77	5.7	145	9.2	234
TTOC12	Teal	605.0	30/19	0.994	12CD	2.1	0.95	6.1	155	9.9	250

Quick Compress Tee Connector for ACSR Conductor, Open Run, TTOC Series (cont.)

CATALOG NUMBER	CONDUCTOR				DIE SIZE	TOTAL WEIGHT		DIMENSIONS			
	CODE WORD	SIZE	STRANDING	DIAMETER		LBS	KG	A		L	
		KCMIL	AL/ST	IN				IN	MM	IN	MM
TTOC10	Kingbird	636.0	18/1	0.940	10CD	1.3	0.59	5.3	133	8.5	216
TTOC11	Rook	636.0	24/7	0.977	11CD	1.7	0.77	5.7	145	9.2	234
TTOC11	Grosbeak	636.0	26/7	0.990	11CD	1.7	0.77	5.7	145	9.2	234
TTOC12	Egret	636.0	30/19	1.019	12CD	2.1	0.95	6.1	155	9.9	250
TTOC10	Swift	636.0	36/1	0.930	10CD	1.3	0.59	5.3	133	8.5	216
TTOC11	Flamingo	666.6	24/7	1.000	11CD	1.7	0.77	5.7	145	9.2	234
TTOC11	Stilt	715.5	24/7	1.036	11CD	1.7	0.77	5.7	145	9.2	234
TTOC12	Starling	715.5	26/7	1.051	12CD	2.1	0.95	6.1	155	9.9	250
TTOC13	Redwing	715.5	30/19	1.081	13CD	2.9	1.32	6.6	167	10.6	269
TTOC12	Cuckoo	795.0	24/7	1.092	12CD	2.1	0.95	6.1	155	9.9	250
TTOC12	Drake	795.0	26/7	1.108	12CD	2.1	0.95	6.1	155	9.9	250
TTOC14	Mallard	795.0	30/19	1.140	14CD	3.5	1.59	7.0	178	11.2	285
TTOC11	Coot	795.0	36/1	1.040	11CD	1.7	0.77	5.7	145	9.2	234
TTOC12	Tern	795.0	45/7	1.063	12CD	2.1	0.95	6.1	155	9.9	250
TTOC12	Condor	795.0	54/7	1.093	12CD	2.1	0.95	6.1	155	9.9	250
TTOC12	Ruddy	900.0	45/7	1.131	12CD	2.1	0.95	6.1	155	9.9	250
TTOC13	Canary	900.0	54/7	1.162	13CD	2.9	1.32	6.6	167	10.6	269
TTOC12	Catbird	954.0	36/1	1.140	12CD	2.1	0.95	6.1	155	9.9	250
TTOC13	Rail	954.0	45/7	1.165	13CD	2.9	1.32	6.6	167	10.6	269
TTOC13	Cardinal	954.0	54/7	1.196	13CD	2.9	1.32	6.6	167	10.6	269
TTOC13	Tanger	1033.5	36/1	1.186	13CD	2.9	1.32	6.6	167	10.6	269
TTOC13	Ortolan	1033.5	45/7	1.212	13CD	2.9	1.32	6.6	167	10.6	269
TTOC14	Curlew	1033.5	54/7	1.244	14CD	3.5	1.59	7.0	178	11.2	285
TTOC14	Bluejay	1113.0	45/7	1.259	14CD	3.5	1.59	7.0	178	11.2	285
TTOC14	Finch	1113.0	54/19	1.293	14CD	3.5	1.59	7.0	178	11.2	285
TTOC14	Bunting	1192.5	45/7	1.302	14CD	3.5	1.59	7.0	178	11.2	285
TTOC15	Grackle	1192.5	54/19	1.333	15CD	4.2	1.91	7.4	189	11.9	302
TTOC15	Bittern	1272.0	45/7	1.345	15CD	4.2	1.91	7.4	189	11.9	302
TTOC15	Pheasant	1272.0	54/19	1.382	15CD	4.2	1.91	7.4	189	11.9	302
TTOC15	Dipper	1351.5	45/7	1.385	15CD	4.2	1.91	7.4	189	11.9	302
TTOC15	Martin	1351.5	54/19	1.424	15CD	4.2	1.91	7.4	189	11.9	302
TTOC16	Bobolink	1431.0	45/7	1.427	16CD	5.0	2.27	7.8	198	12.5	316
TTOC16	Plover	1431.0	54/19	1.465	16CD	5.0	2.27	7.8	198	12.5	316
TTOC16	Nuthatch	1510.5	45/7	1.466	16CD	5.0	2.27	7.8	198	12.5	316
TTOC16	Parrot	1510.5	54/19	1.506	16CD	5.0	2.27	7.8	198	12.5	316
TTOC16	Lapwing	1590.0	45/7	1.504	16CD	5.0	2.27	7.8	198	12.5	316
TTOC17	Falcon	1590.0	54/19	1.545	17CD	5.9	2.68	8.3	210	13.1	333
TTOC17	Chukar	1780.0	84/19	1.602	17CD	5.9	2.68	8.3	210	13.1	333
TTOC18	—	2034.0	72/7	1.681	18CD	7.0	3.16	8.6	219	13.7	348
TTOC19	Bluebird	2156.0	84/19	1.762	19CD	8.0	3.63	9.1	230	14.4	364
TTOC19	Kiwi	2167.0	72/7	1.737	19CD	8.0	3.63	9.1	230	14.4	364
TTOC19	Thrasher	2312.0	76/19	1.802	19CD	8.0	3.63	9.1	230	14.4	364
TTOC20	Joree	2515.0	76/19	1.880	20CD	9.2	4.17	9.4	240	14.9	378

Quick Compress Tee Tap for ACSR Conductor, Open Run, TTOP Series

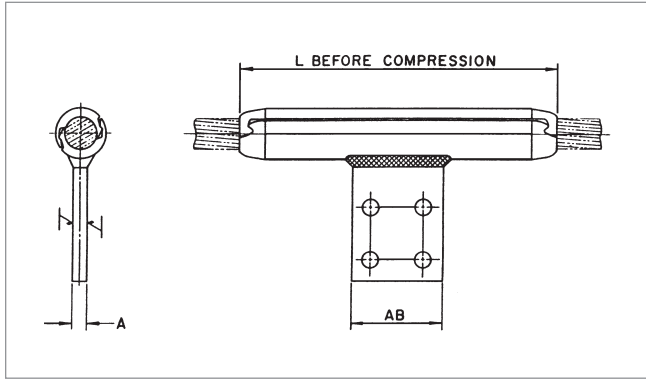

The TTOP Series Open Run Tee Tap is a permanent or temporary drop. By using a high strength alloy, the compression length has been shortened for less compression bites.

The run portion incorporates an improved design of interlocking extrusions, providing a permanent grip on the conductor when compressed.

The end tapers of all compression accessories are supplied with a High Voltage finish for die size sections 12CD and above.

The square edges of bolted pads of the compression accessories could cause Corona. Pads with edges and corners rounded can be supplied by adding the catalog suffix 'EHV'.

Ordering Instructions

Step 1: Assembly Catalog Number

Determine the assembly catalog number based on the conductor being used.

Step 2: Extra High Voltage Finish

For Extra High Voltage Finish, use 'EHV'. (≥ 345 kV)

For Standard Finish, leave blank. (< 345 kV)

Step 3: Assemble Catalog Number.

Assy Catalog Number	+	EHV Finish
---------------------	---	------------

Example:

A tee tap for 795 Drake with EHV finish, the complete catalog number is:

TTOP12EHV

Notes:

1. Installation Instructions for Tee Taps are on page 274.
2. For more information on die selection and ordering instructions, see Tools and Equipment tab in this catalog.

Quick Compress Tee Tap for ACSR Conductor, Open Run, TTOP Series (cont.)

CATALOG NUMBER	CONDUCTOR				DIE SIZE	WEIGHT		DIMENSIONS						PAD SIZE
	CODE WORD	SIZE	STRAND-ING	DIAMETER		ALUMINUM		A		L		AB		
		KCMIL	AL/ST	IN		LBS	KG	IN	MM	IN	MM	IN	MM	
TTOP07	Owl	266.8	6/7	0.633	07CD	0.6	0.27	0.4	10	7.4	187	2.0	51	B
TTOP07	Waxwing	266.8	18/1	0.609	07CD	0.6	0.27	0.4	10	7.4	187	2.0	51	B
TTOP07	Partridge	266.8	26/7	0.642	07CD	0.6	0.27	0.4	10	7.4	187	2.0	51	B
TTOP08	Ostrich	300	26/7	0.680	08CD	0.7	0.34	0.4	10	8.0	202	2.0	51	B
TTOP08	Merlin	336.4	18/1	0.684	08CD	0.7	0.34	0.4	10	8.0	202	2.0	51	B
TTOP08	Linnet	336.4	26/7	0.720	08CD	0.7	0.34	0.4	10	8.0	202	2.0	51	B
TTOP09	Oriole	336.4	30/7	0.741	09CD	0.9	0.41	0.4	10	8.5	215	2.0	51	B
TTOP08	Chickadee	397.5	18/1	0.743	08CD	0.7	0.34	0.4	10	8.0	202	2.0	51	B
TTOP09	Brant	397.5	24/7	0.772	09CD	0.9	0.41	0.4	10	8.5	215	2.0	51	B
TTOP09	Ibis	397.5	26/7	0.783	09CD	0.9	0.41	0.4	10	8.5	215	2.0	51	B
TTOP10	Lark	397.5	30/7	0.806	10CD	1.0	0.45	0.4	10	9.0	229	2.0	51	B
TTOP09	Pelican	477	18/1	0.814	09CD	0.9	0.41	0.4	10	8.5	215	2.0	51	B
TTOP09	Flicker	477	24/7	0.846	09CD	0.9	0.41	0.4	10	8.5	215	2.0	51	B
TTOP10	Hawk	477	26/7	0.858	10CD	1.0	0.45	0.4	10	9.0	229	2.0	51	B
TTOP11	Hen	477	30/7	0.883	11CD	1.7	0.77	0.5	13	10.5	267	3.0	76	D
TTOP10	Osprey	556.5	18/1	0.879	10CD	1.0	0.45	0.4	10	9.0	229	2.0	51	B
TTOP10	Parakeet	556.5	24/7	0.914	10CD	1.0	0.45	0.4	10	9.0	229	2.0	51	B
TTOP10	Dove	556.5	26/7	0.927	10CD	1.0	0.45	0.4	10	9.0	229	2.0	51	B
TTOP11	Eagle	556.5	30/7	0.953	11CD	1.7	0.77	0.5	13	10.5	267	3.0	76	D
TTOP11	Peacock	605	24/7	0.953	11CD	1.7	0.77	0.5	13	10.5	267	3.0	76	D
TTOP11	Squab	605	26/7	0.966	11CD	1.7	0.77	0.5	13	10.5	267	3.0	76	D
TTOP12	Teal	605	30/19	0.994	12CD	2.0	0.91	0.5	13	11.1	281	3.0	76	D
TTOP10	Kingbird	636	18/1	0.940	10CD	1.0	0.45	0.4	10	9.0	229	2.0	51	B
TTOP11	Rook	636	24/7	0.977	11CD	1.7	0.77	0.5	13	10.5	267	3.0	76	D
TTOP11	Grosbeak	636	26/7	0.990	11CD	1.7	0.77	0.5	13	10.5	267	3.0	76	D
TTOP12	Egret	636	30/19	1.019	12CD	2.0	0.91	0.5	13	11.1	281	3.0	76	D
TTOP10	Swift	636	36/1	0.930	10CD	1.0	0.45	0.4	10	9.0	229	2.0	51	B
TTOP11	Flamingo	666.6	24/7	1.000	11CD	1.7	0.77	0.5	13	10.5	267	3.0	76	D
TTOP11	Stilt	715.5	24/7	1.036	11CD	1.7	0.77	0.5	13	10.5	267	3.0	76	D
TTOP12	Starling	715.5	26/7	1.051	12CD	2.0	0.91	0.5	13	11.1	281	3.0	76	D
TTOP13	Redwing	715.5	30/19	1.081	13CD	2.4	1.09	.50	13	11.6	294	3.0	76	D
TTOP12	Cuckoo	795	24/7	1.092	12CD	2.0	0.91	0.5	13	11.1	281	3.0	76	D
TTOP12	Drake	795	26/7	1.108	12CD	2.0	0.91	0.5	13	11.1	281	3.0	76	D
TTOP14	Mallard	795	30/19	1.140	14CD	2.8	1.27	0.5	13	12.1	307	3.0	76	D
TTOP11	Coot	795	36/1	1.040	11CD	1.7	0.77	0.5	13	10.5	267	3.0	76	D
TTOP12	Tern	795	45/7	1.063	12CD	2.0	0.91	0.5	13	11.1	281	3.0	76	D



Quick Compress Tee Tap for ACSR Conductor, Open Run, TTOP Series (cont.)

CATALOG NUMBER	CONDUCTOR				DIE SIZE	WEIGHT		DIMENSIONS						PAD SIZE
	CODE WORD	SIZE	STRAND-ING	DIAMETER		ALUMINUM		A		L		AB		
		KCMIL	AL/ST	IN		LBS	KG	IN	MM	IN	MM	IN	MM	
TTOP12	Condor	795	54/7	1.093	12CD	2.0	0.91	0.5	13	11.1	281	3.0	76	D
TTOP12	Ruddy	900	45/7	1.131	12CD	2.0	0.91	0.5	13	11.1	281	3.0	76	D
TTOP13	Canary	900	54/7	1.162	13CD	2.4	1.09	,50	13	11.6	294	3.0	76	D
TTOP12	Catbird	954	36/1	1.140	12CD	2.0	0.91	0.5	13	11.1	281	3.0	76	D
TTOP13	Rail	954	45/7	1.165	13CD	2.4	1.09	,50	13	11.6	294	3.0	76	D
TTOP13	Cardinal	954	54/7	1.196	13CD	2.4	1.09	,50	13	11.6	294	3.0	76	D
TTOP13	Tanger	1033.5	36/1	1.186	13CD	2.4	1.09	,50	13	11.6	294	3.0	76	D
TTOP13	Ortolan	1033.5	45/7	1.212	13CD	2.4	1.09	,50	13	11.6	294	3.0	76	D
TTOP14	Curlew	1033.5	54/7	1.244	14CD	2.8	1.27	0.5	13	12.1	307	3.0	76	D
TTOP14	Bluejay	1113	45/7	1.259	14CD	2.8	1.27	0.5	13	12.1	307	3.0	76	D
TTOP14	Finch	1113	54/19	1.293	14CD	2.8	1.27	0.5	13	12.1	307	3.0	76	D
TTOP14	Bunting	1192.5	45/7	1.302	14CD	2.8	1.27	0.5	13	12.1	307	3.0	76	D
TTOP15	Grackle	1192.5	54/19	1.333	15CD	3.3	1.50	0.5	13	12.6	321	3.0	76	D
TTOP15	Bittern	1272	45/7	1.345	15CD	3.3	1.50	0.5	13	12.6	321	3.0	76	D
TTOP15	Pheasant	1272	54/19	1.382	15CD	3.3	1.50	0.5	13	12.6	321	3.0	76	D
TTOP15	Dipper	1351.5	45/7	1.385	15CD	3.3	1.50	0.5	13	12.6	321	3.0	76	D
TTOP15	Martin	1351.5	54/19	1.424	15CD	3.3	1.50	0.5	13	12.6	321	3.0	76	D
TTOP16	Bobolink	1431	45/7	1.427	16CD	3.7	1.68	0.5	13	13.2	334	3.0	76	D
TTOP16	Plover	1431	54/19	1.465	16CD	3.7	1.68	0.5	13	13.2	334	3.0	76	D
TTOP16	Nuthatch	1510.5	45/7	1.466	16CD	3.7	1.68	0.5	13	13.2	334	3.0	76	D
TTOP16	Parrot	1510.5	54/19	1.506	16CD	3.7	1.68	0.5	13	13.2	334	3.0	76	D
TTOP16	Lapwing	1590	45/7	1.504	16CD	3.7	1.68	0.5	13	13.2	334	3.0	76	D
TTOP17	Falcon	1590	54/19	1.545	17CD	5.2	2.36	0.8	19	14.6	370	4.0	102	E
TTOP17	Chukar	1780	84/19	1.602	17CD	5.2	2.36	0.8	19	14.6	370	4.0	102	E
TTOP18	—	2034	72/7	1.681	18CD	5.9	2.68	0.8	19	15.0	380	4.0	102	E
TTOP19	Bluebird	2156	84/19	1.762	19CD	6.5	2.95	0.8	19	15.5	393	4.0	102	E
TTOP19	Kiwi	2167	72/7	1.737	19CD	6.5	2.95	0.8	19	15.5	393	4.0	102	E
TTOP19	Thrasher	2312	76/19	1.802	19CD	6.5	2.95	0.8	19	15.5	393	4.0	102	E
TTOP20	Joree	2515	76/19	1.880	20CD	7.2	3.27	0.8	19	15.9	403	4.0	102	E



Quick Compress®

QuickCompress® – ACSR

Quick Compress Dead Ends for AAC Conductor, Eye Type, Single Tongue, VESE/HESE Series

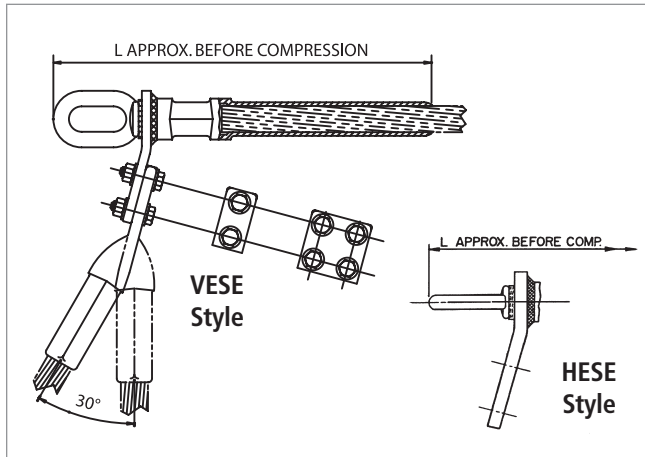

The Quick Compress Dead Ends are designed for fast and easy installation. By using a high strength alloy, the compression length has been shortened for less compression bites while maintaining a minimum 95% of the ASTM rated strength. The steel eye is pre-compressed and the dead end pre-filled, eliminating installation steps.

The dead end tongue and terminal pad are each constructed with a 15° angle, which permits the terminal connector to be bolted in either the straight or the 30° position. Both sides of the pad are finished, creating excellent electrical contact surfaces. For pad to pad connections, AFL recommends the use of No. 2 EJC.

The end tapers of all compression accessories are supplied with a high voltage finish for die sizes 12CD and above. Corona bolts are furnished standard on 15° terminals for these section sizes.

The square edges of bolted pads of the compression accessories could cause Corona. Pads with rounded edges and corners can be supplied by adding the catalog suffix 'EHV'.

Ordering Instructions

Step 1: Assembly Catalog Number

Determine the assembly catalog number based on the conductor being used.

Step 2: Terminal Connector

For an assembly without a terminal connector, use 'NT'.
For an assembly with a terminal connector, leave blank.

Step 3: Extra High Voltage Finish

For Extra High Voltage Finish, use 'EHV'. (≥ 345 kV)
For Standard Finish, leave blank. (< 345 kV)

Step 4: Assemble Catalog Number.



Example:

For a vertical eye dead end with no terminal and EHV finish for 795 Arbutus, the complete catalog number is:

VESE110NTEHV

Notes:

1. Assembly Catalog Number includes dead end, terminal connector and aluminum hardware.
2. Eye Dimensions are on page 257.
3. Pad Dimensions are on page 257.
4. Installation Instructions for Dead Ends are on page 266.
5. Installation Instructions for Terminals are on page 272.
6. For more information on die selection and ordering instructions, see Tools and Equipment tab in this catalog.



Quick Compress Dead Ends for AAC Conductor, Eye Type, Single Tongue, VESE/HESE Series (cont.)

ASSEMBLY CATALOG NUMBER		CONDUCTOR				DIE SIZE	TOTAL WEIGHT		DIMENSION L		PAD SIZE
VERTICAL EYE	HORIZONTAL EYE	CODE WORD	SIZE KCMIL	STRANDING	DIAMETER IN		LBS	KG	IN	MM	
VESE070	HESE070	Peony	300.6	19	0.629	07CD	1.6	0.73	8.9	226	B
VESE070	HESE070	Tulip	336.4	19	0.666	07CD	1.6	0.73	8.9	226	B
VESE070	HESE070	Daffodil	350.0	19	0.679	07CD	1.6	0.73	8.9	226	B
VESE080	HESE080	Canna	397.5	19	0.724	08CD	2.0	0.91	9.3	236	B
VESE090	HESE090	Goldentuft	450.0	19	0.770	09CD	2.8	1.27	10.4	265	B
VESE090	HESE090	Cosmos	477.0	19	0.793	09CD	2.8	1.27	10.4	265	B
VESE090	HESE090	Zinnia	500.0	19	0.811	09CD	2.8	1.27	10.4	265	B
VESE100	HESE100	Dahlia	556.5	19	0.856	10CD	3.2	1.45	10.9	278	B
VESE100	HESE100	Meadowsweet	600.0	37	0.891	10CD	3.2	1.45	10.9	278	B
VESE100	HESE100	Orchid	636.0	37	0.918	10CD	3.2	1.45	10.9	278	B
VESE100	HESE100	Heuchera	650.0	37	0.928	10CD	3.2	1.45	10.9	278	B
VESE110	HESE110	Verbena	700.0	37	0.963	11CD	5.1	2.31	11.8	298	D
VESE110	HESE110	Violet	715.5	37	0.974	11CD	5.1	2.31	11.8	298	D
VESE110	HESE110	Petunia	750.0	37	0.997	11CD	5.1	2.31	11.8	298	D
VESE110	HESE110	Arbutus	795.0	37	1.026	11CD	5.1	2.31	11.8	298	D
VESE110	HESE110	—	800.0	61	1.031	11CD	5.1	2.31	11.8	298	D
VESE120	HESE120	Cockscomb	900.0	37	1.092	12CD	5.6	2.54	12.2	310	D
VESE120	HESE120	Magnolia	954.0	37	1.124	12CD	5.6	2.54	12.2	310	D
VESE130	HESE130	Hawkweed	1000.0	37	1.151	13CD	7.5	3.40	14.1	359	D
VESE130	HESE130	Bluebell	1033.5	37	1.170	13CD	7.5	3.40	14.1	359	D
VESE130	HESE130	Marigold	1113.0	61	1.216	13CD	7.5	3.40	14.1	359	D
VESE140	HESE140	Hawthorn	1192.5	61	1.258	14CD	8.4	3.81	14.6	370	D
VESE140	HESE140	—	1250.0	91	1.289	14CD	8.4	3.81	14.6	370	D
VESE140	HESE140	Narcissus	1272.0	61	1.300	14CD	8.4	3.81	14.6	370	D
VESE140	HESE140	—	1300.0	91	1.315	14CD	8.4	3.81	14.6	370	D
VESE150	HESE150	Columbine	1351.5	61	1.340	15CD	9.3	4.22	15.0	381	D
VESE150	HESE150	Carnation	1431.0	61	1.379	15CD	9.3	4.22	15.0	381	D
VESE150	HESE150	—	1500.0	91	1.412	15CD	9.3	4.22	15.0	381	D
VESE150	HESE150	Gladiolus	1510.5	61	1.417	15CD	9.3	4.22	15.0	381	D
VESE160	HESE160	Coreopsis	1590.0	61	1.454	16CD	11.8	5.35	16.3	414	D
VESE170	HESE170	Jessamine	1750.0	61	1.525	17CD	14.5	6.58	16.7	424	E
VESE180	HESE180	Cowslip	2000.0	91	1.630	18CD	15.7	7.12	17.1	435	E
VESE190	HESE190	Sagebrush	2250.0	91	1.729	19CD	20.0	9.07	19.1	484	E
VESE190	HESE190	—	2300.0		1.750	19CD	20.0	9.07	19.1	484	E
VESE200	HESE200	Lupine	2500.0	91	1.823	20CD	21.3	9.66	19.5	495	E

QuickCompress® - AAC

Quick Compress Dead Ends for AAC Conductor, Eye Type, Double Tongue, VEDE/HEDE Series

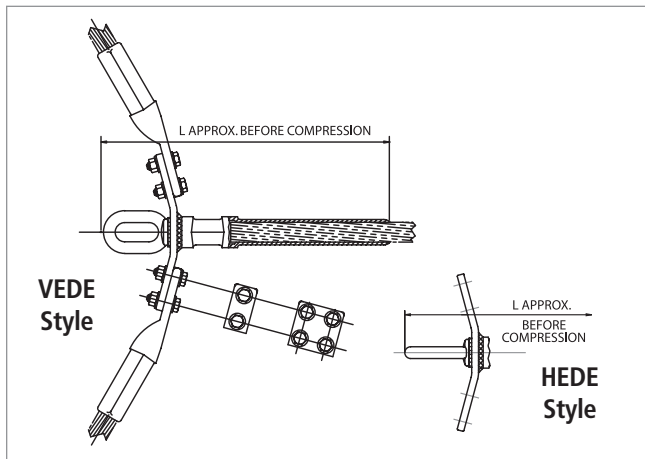

The Quick Compress Dead Ends are designed for fast and easy installation. By using a high strength alloy, the compression length has been shortened for less compression bites while maintaining a minimum 95% of the ASTM rated strength. The steel eye is pre-compressed and the dead end pre-filled, eliminating installation steps.

The dead end tongue and terminal pad are each constructed with a 15° angle, which permits the terminal connector to be bolted in either the straight or the 30° position. Both sides of the pad are finished, creating excellent electrical contact surfaces. For pad to pad connections, AFL recommends the use of No. 2 EJC.

The end tapers of all compression accessories are supplied with a high voltage finish for die sizes 12CD and above. Corona bolts are furnished standard on 15° terminals for these section sizes. The square edges of bolted pads of the compression accessories could cause Corona. Pads with rounded edges and corners can be supplied by adding the catalog suffix 'EHV'.

Ordering Instructions

Step 1: Assembly Catalog Number

Determine the assembly catalog number based on the conductor being used.

Step 2: Terminal Connector

For an assembly without a terminal connector, use 'NT'.
For an assembly with a terminal connector, leave blank.

Step 3: Extra High Voltage Finish

For Extra High Voltage Finish, use 'EHV'. (≥ 345 kV)
For Standard Finish, leave blank. (< 345 kV)

Step 4: Assemble Catalog Number.



Example:

For a vertical eye dead end with no terminal and EHV finish for 795 Arbutus, the complete catalog number is:

VEDE110NTEHV

Notes:

1. Assembly Catalog Number includes dead end, two terminal connectors and aluminum hardware.
2. Eye Dimensions are on page 257.
3. Pad Dimensions are on page 257.
4. Installation Instructions for Dead Ends are on page 266.
5. Installation Instructions for Terminals are on page 272.
6. For more information on die selection and ordering instructions, see Tools and Equipment tab in this catalog.



Quick Compress Dead Ends for AAC Conductor, Eye Type, Double Tongue, VEDE/HEDE Series (cont.)

ASSEMBLY CATALOG NUMBER		CONDUCTOR				DIE SIZE	TOTAL WEIGHT		DIMENSION L		PAD SIZE
VERTICAL EYE	HORIZONTAL EYE	CODE WORD	SIZE	STRANDING	DIAMETER		LBS	KG	IN	MM	
			KCMIL	AL	IN						
VEDE070	HEDE070	Peony	300.0	19	0.629	07CD	2.5	1.13	8.9	226	B
VEDE070	HEDE070	Tulip	336.4	19	0.666	07CD	2.5	1.13	8.9	226	B
VEDE070	HEDE070	Daffodil	350.0	19	0.679	07CD	2.5	1.13	8.9	226	B
VEDE080	HEDE080	Canna	397.5	19	0.724	08CD	3.0	1.36	9.3	236	B
VEDE090	HEDE090	Goldentuft	450.0	19	0.770	09CD	4.1	1.86	10.4	265	B
VEDE090	HEDE090	Cosmos	477.0	19	0.793	09CD	4.1	1.86	10.4	265	B
VEDE090	HEDE090	Zinnia	500.0	19	0.811	09CD	4.1	1.86	10.4	265	B
VEDE100	HEDE100	Dahlia	556.5	19	0.856	10CD	4.8	2.18	10.9	278	B
VEDE100	HEDE100	Meadowsweet	600.0	37	0.891	10CD	4.8	2.18	10.9	278	B
VEDE100	HEDE100	Orchid	636.0	37	0.918	10CD	4.8	2.18	10.9	278	B
VEDE100	HEDE100	Heuchera	650.0	37	0.928	10CD	4.8	2.18	10.9	278	B
VEDE110	HEDE110	Verbena	700.0	37	0.963	11CD	7.3	3.31	11.8	298	D
VEDE110	HEDE110	Violet	715.5	37	0.974	11CD	7.3	3.31	11.8	298	D
VEDE110	HEDE110	Petunia	750.0	37	0.997	11CD	7.3	3.31	11.8	298	D
VEDE110	HEDE110	Arbutus	795.0	37	1.026	11CD	7.3	3.31	11.8	298	D
VEDE110	HEDE110	—	800.0	61	1.031	11CD	7.3	3.31	11.8	298	D
VEDE120	HEDE120	Cockscomb	900.0	37	1.092	12CD	8.3	3.76	12.2	310	D
VEDE120	HEDE120	Magnolia	954.0	37	1.124	12CD	8.3	3.76	12.2	310	D
VEDE130	HEDE130	Hawkweed	1000.0	37	1.151	13CD	10.6	4.80	14.1	359	D
VEDE130	HEDE130	Bluebell	1033.5	37	1.170	13CD	10.6	4.80	14.1	359	D
VEDE130	HEDE130	Marigold	1113.0	61	1.216	13CD	10.6	4.80	14.1	359	D
VEDE140	HEDE140	Hawthorn	1192.5	61	1.258	14CD	12.0	5.44	14.6	370	D
VEDE140	HEDE140	—	1250.0	91	1.289	14CD	12.0	5.44	14.6	370	D
VEDE140	HEDE140	Narcissus	1272.0	61	1.300	14CD	12.0	5.44	14.6	370	D
VEDE140	HEDE140	—	1300.0	91	1.315	14CD	12.0	5.44	14.6	370	D
VEDE150	HEDE150	Columbine	1351.5	61	1.340	15CD	13.3	6.03	15.0	381	D
VEDE150	HEDE150	Carnation	1431.0	61	1.379	15CD	13.3	6.03	15.0	381	D
VEDE150	HEDE150	—	1500.0	91	1.412	15CD	13.3	6.03	15.0	381	D
VEDE150	HEDE150	Gladiolus	1510.5	61	1.417	15CD	13.3	6.03	15.0	381	D
VEDE160	HEDE160	Coreopsis	1590.0	61	1.454	16CD	16.4	7.44	16.3	414	D
VEDE170	HEDE170	Jessamine	1750.0	61	1.525	17CD	20.2	9.16	16.7	424	E
VEDE180	HEDE180	Cowslip	2000.0	91	1.630	18CD	22.0	9.98	17.1	435	E
VEDE190	HEDE190	Sagebrush	2250.0	91	1.729	19CD	27.4	12.43	19.1	484	E
VEDE190	HEDE190	—	2300.0	91	1.750	19CD	27.4	12.43	19.1	484	E
VEDE200	HEDE200	Lupine	2500.0	91	1.823	20CD	29.2	13.24	19.5	495	E

QuickCompress® - AAC

Quick Compress Dead Ends for AAC Conductor, Adjustable Clevis Type, Single Tongue, ACSE Series

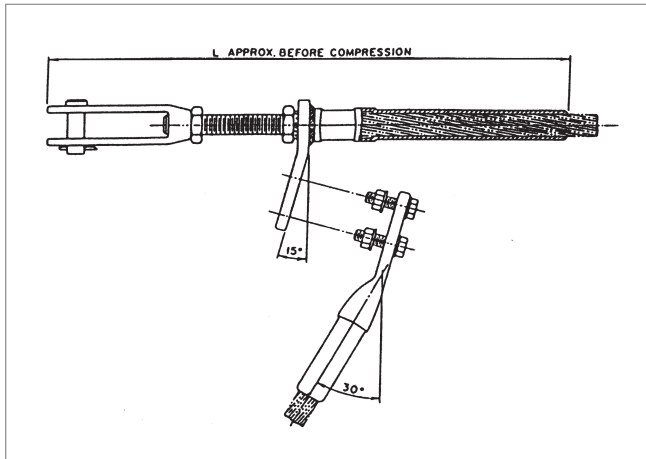

The Quick Compress Dead Ends are designed for fast and easy installation. By using a high strength alloy, the compression length has been shortened for less compression bites while maintaining a minimum 95% of the ASTM rated strength. The adjustable steel clevis is pre-compressed and the dead end pre-filled, eliminating installation steps.

The dead end tongue and terminal pad are each constructed with a 15° angle, which permits the terminal connector to be bolted in either the straight or the 30° position. Both sides of the pad are finished, creating excellent electrical contact surfaces. For pad to pad connections, AFL recommends the use of No. 2 EJC.

The end tapers of all compression accessories are supplied with a high voltage finish for die sizes 12CD and above. Corona bolts are furnished standard on 15° terminals for these section sizes. The square edges of bolted pads of the compression accessories could cause Corona. Pads with rounded edges and corners can be supplied by adding the catalog suffix 'EHV'.

Ordering Instructions

Step 1: Assembly Catalog Number

Determine the assembly catalog number based on the conductor being used.

Step 2: Terminal Connector

For an assembly without a terminal connector, use 'NT'.
For an assembly with a terminal connector, leave blank.

Step 3: Extra High Voltage Finish

For Extra High Voltage Finish, use 'EHV'. (≥ 345 kV)
For Standard Finish, leave blank. (< 345 kV)

Step 4: Assemble Catalog Number.

Assy Catalog Number	+	Terminal Connector	+	EHV Finish
------------------------	---	-----------------------	---	---------------

Example:

For an adjustable clevis dead end with no terminal and EHV finish for 795 Arbutus, the complete catalog number is:

ACSE110NTEHV

Notes:

1. Assembly Catalog Number includes dead end, terminal connector and aluminum hardware.
2. Clevis Dimensions are on page 258.
3. Pad Dimensions are on page 257.
4. Installation Instructions for Dead Ends are on page 266.
5. Installation Instructions for Terminals are on page 272.
6. For more information on die selection and ordering instructions, see Tools and Equipment tab in this catalog.

Quick Compress Dead Ends for AAC Conductor, Adjustable Clevis Type, Single Tongue, ACSE Series (cont.)

ASSEMBLY CATALOG NUMBER	CONDUCTOR				DIE SIZE	TOTAL WEIGHT		DIMENSION L		PAD SIZE
	CODE WORD	SIZE	STRANDING	DIAMETER		LBS	KG	IN	MM	
		KCMIL		IN						
ACSE070	Peony	300.0	19	0.629	07CD	4.1	1.86	16.6	442	B
ACSE070	Tulip	336.4	19	0.666	07CD	4.1	1.86	16.6	442	B
ACSE070	Daffodil	350.0	19	0.679	07CD	4.1	1.86	16.6	442	B
ACSE080	Canna	397.5	19	0.724	08CD	4.8	2.18	17.2	437	B
ACSE090	Goldentuft	450.0	19	0.770	09CD	5.8	2.63	18.3	465	B
ACSE090	Cosmos	477.0	19	0.793	09CD	5.8	2.63	18.3	465	B
ACSE090	Zinnia	500.0	19	0.811	09CD	5.8	2.63	18.3	465	B
ACSE100	Dahlia	556.5	19	0.856	10CD	6.2	2.81	18.8	476	B
ACSE100	Meadowsweet	600.0	37	0.891	10CD	6.2	2.81	18.8	476	B
ACSE100	Orchid	636.0	37	0.918	10CD	6.2	2.81	18.8	476	B
ACSE100	Heuchera	650.0	37	0.928	10CD	6.2	2.81	18.8	476	B
ACSE110	Verbena	700.0	37	0.963	11CD	10.7	4.85	21.8	554	D
ACSE110	Violet	715.5	37	0.974	11CD	10.7	4.85	21.8	554	D
ACSE110	Petunia	750.0	37	0.997	11CD	10.7	4.85	21.8	554	D
ACSE110	Arbutus	795.0	37	1.026	11CD	10.7	4.85	21.8	554	D
ACSE110	—	800.0	61	1.031	11CD	10.7	4.85	21.8	554	D
ACSE120	Cockscomb	900.0	37	1.092	12CD	11.2	5.08	22.3	565	D
ACSE120	Magnolia	954.0	37	1.124	12CD	11.2	5.08	22.3	565	D
ACSE130	Hawkweed	1000.0	37	1.151	13CD	13.9	6.30	23.8	605	D
ACSE130	Bluebell	1033.5	37	1.170	13CD	13.9	6.30	23.8	605	D
ACSE130	Marigold	1113.0	61	1.216	13CD	13.9	6.30	23.8	605	D
ACSE140	Hawthorn	1192.5	61	1.258	14CD	14.8	6.71	24.3	616	D
ACSE140	—	1250.0	91	1.289	14CD	14.8	6.71	24.3	616	D
ACSE140	Narcissus	1272.0	61	1.300	14CD	14.8	6.71	24.3	616	D
ACSE140	—	1300.0	91	1.315	14CD	14.8	6.71	24.3	616	D
ACSE150	Columbine	1351.5	61	1.340	15CD	15.7	7.12	24.7	627	D
ACSE150	Carnation	1431.0	61	1.379	15CD	15.7	7.12	24.7	627	D
ACSE150	—	1500.0	91	1.412	15CD	15.7	7.12	24.7	627	D
ACSE150	Gladiolus	1510.5	61	1.417	15CD	15.7	7.12	24.7	627	D
ACSE160	Coreopsis	1590.0	61	1.454	16CD	21.9	9.93	28.4	721	D
ACSE170	Jessamine	1750.0	61	1.525	17CD	24.6	11.16	28.9	734	E
ACSE180	Cowslip	2000.0	91	1.630	18CD	25.8	11.70	29.3	743	E
ACSE190	Sagebrush	2250.0	91	1.729	19CD	33.9	15.38	31.1	789	E
ACSE190	—	2300.0	91	1.750	19CD	33.9	15.38	31.1	789	E
ACSE200	Lupine	2500.0	91	1.823	20CD	35.2	15.97	31.5	800	E

Quick Compress Dead Ends for AAC Conductor, Adjustable Eye Type, Single Tongue, AESE Series

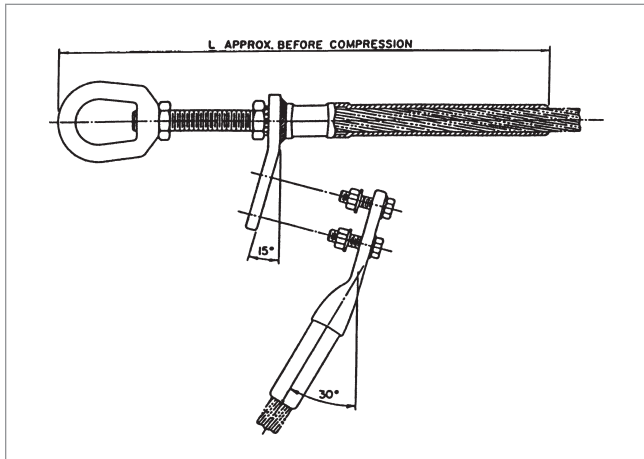

The Quick Compress Dead Ends are designed for fast and easy installation. By using a high strength alloy, the compression length has been shortened for less compression bites while maintaining a minimum 95% of the ASTM rated strength. The adjustable steel eye is pre-compressed and the dead end pre-filled, eliminating installation steps.

The dead end tongue and terminal pad are each constructed with a 15° angle, which permits the terminal connector to be bolted in either the straight or the 30° position. Both sides of the pad are finished, creating excellent electrical contact surfaces. For pad to pad connections, AFL recommends the use of No. 2 EJC.

The end tapers of all compression accessories are supplied with a high voltage finish for die sizes 12CD and above. Corona bolts are furnished standard on 15° terminals for these section sizes. The square edges of bolted pads of the compression accessories could cause Corona. Pads with rounded edges and corners can be supplied by adding the catalog suffix 'EHV'.

Ordering Instructions

Step 1: Assembly Catalog Number

Determine the assembly catalog number based on the conductor being used.

Step 2: Terminal Connector

For an assembly without a terminal connector, use 'NT'.
For an assembly with a terminal connector, leave blank.

Step 3: Extra High Voltage Finish

For Extra High Voltage Finish, use 'EHV'. (≥ 345 kV)
For Standard Finish, leave blank. (< 345 kV)

Step 4: Assemble Catalog Number.

Assy Catalog Number	+	Terminal Connector	+	EHV Finish
---------------------	---	--------------------	---	------------

Example:

For an adjustable eye dead end with no terminal and EHV finish for 795 Arbutus, the complete catalog number is:

AESE110NTEHV

Notes:

1. Assembly Catalog Number includes dead end, terminal connector and aluminum hardware.
2. Eye Dimensions are on page 258.
3. Pad Dimensions are on page 257.
4. Installation Instructions for Dead Ends are on page 266.
5. Installation Instructions for Terminals are on page 272.
6. For more information on die selection and ordering instructions, see Tools and Equipment tab in this catalog.

Quick Compress Dead Ends for AAC Conductor, Adjustable Eye Type, Single Tongue, AESE Series (cont.)

ASSEMBLY CATALOG NUMBER	CONDUCTOR				DIE SIZE	TOTAL WEIGHT		DIMENSION L		PAD SIZE
	CODE WORD	SIZE	STRANDING	DIAMETER		LBS	KG	IN	MM	
		KCMIL		IN						
AESE070	Peony	300.6	19	0.629	07CD	2.6	1.18	13.8	351	B
AESE070	Tulip	336.4	19	0.666	07CD	2.6	1.18	13.8	351	B
AESE070	Daffodil	350.0	19	0.679	07CD	2.6	1.18	13.8	351	B
AESE080	Canna	397.5	19	0.724	08CD	3.7	1.68	14.8	377	B
AESE090	Goldentuft	450.0	19	0.770	09CD	5.3	2.40	16.4	415	B
AESE090	Cosmos	477.0	19	0.793	09CD	5.3	2.40	16.4	415	B
AESE090	Zinnia	500.0	19	0.811	09CD	5.3	2.40	16.4	415	B
AESE100	Dahlia	556.5	19	0.856	10CD	5.7	2.59	16.8	427	B
AESE100	Meadowsweet	600.0	37	0.891	10CD	5.7	2.59	16.8	427	B
AESE100	Orchid	636.0	37	0.918	10CD	5.7	2.59	16.8	427	B
AESE100	Heuchera	650.0	37	0.928	10CD	5.7	2.59	16.8	427	B
AESE110	Verbena	700.0	37	0.963	11CD	8.7	3.95	19.1	485	D
AESE110	Violet	715.5	37	0.974	11CD	8.7	3.95	19.1	485	D
AESE110	Petunia	750.0	37	0.997	11CD	8.7	3.95	19.1	485	D
AESE110	Arbutus	795.0	37	1.026	11CD	8.7	3.95	19.1	485	D
AESE110	—	800.0	61	1.031	11CD	8.7	3.95	19.1	485	D
AESE120	Cockscomb	900.0	37	1.092	12CD	9.3	4.22	19.6	497	D
AESE120	Magnolia	954.0	37	1.124	12CD	9.3	4.22	19.6	497	D
AESE130	Hawkweed	1000.0	37	1.151	13CD	13.1	5.94	21.6	549	D
AESE130	Bluebell	1033.5	37	1.170	13CD	13.1	5.94	21.6	549	D
AESE130	Marigold	1113.0	61	1.216	13CD	13.1	5.94	21.6	549	D
AESE140	Hawthorn	1192.5	61	1.258	14CD	14.0	6.35	22.1	561	D
AESE140	—	1250.0	91	1.289	14CD	14.0	6.35	22.1	561	D
AESE140	Narcissus	1272.0	61	1.300	14CD	14.0	6.35	22.1	561	D
AESE140	—	1300.0	91	1.315	14CD	14.0	6.35	22.1	561	D
AESE150	Columbine	1351.5	61	1.340	15CD	14.9	6.76	22.5	571	D
AESE150	Carnation	1431.0	61	1.379	15CD	14.9	6.76	22.5	571	D
AESE150	—	1500.0	91	1.412	15CD	14.9	6.76	22.5	571	D
AESE150	Gladiolus	1510.5	61	1.417	15CD	14.9	6.76	22.5	571	D
AESE160	Coreopsis	1590.0	61	1.454	16CD	21.8	9.89	25.7	653	D
AESE170	Jessamine	1750.0	61	1.525	17CD	24.6	11.16	26.2	664	E
AESE180	Cowslip	2000.0	91	1.630	18CD	25.8	11.70	26.5	674	E
AESE190	Sagebrush	2250.0	91	1.729	19CD	31.0	14.60	28.1	713	E
AESE190	—	2300.0	91	1.750	19CD	31.0	14.60	28.1	713	E
AESE200	Lupine	2500.0	91	1.823	20CD	32.3	14.65	28.5	724	E

Quick Compress Compression Joints for AAC Conductor, CJE Series

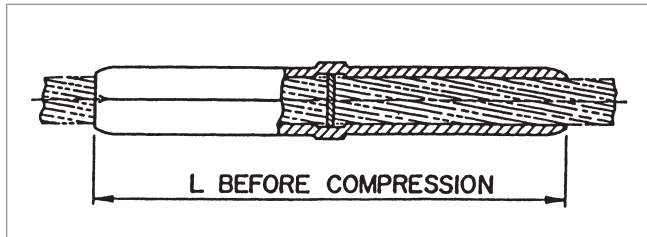

The Quick Compress CJE Series Joints are designed for fast and easy installation. By using a high strength alloy, the compression length has been shortened for less compression bites while maintaining a minimum 95% of the ASTM rated strength. The compression joint is pre-filled, eliminating an installation step. Each compression joint has a center stop to ensure proper insertion of the conductor.

The end tapers of all compression accessories are supplied with a high voltage finish for die size sections 12CD and above.

Ordering Instructions

Step 1: Assembly Catalog Number

Determine the assembly catalog number based on the conductor being used.

Example:

A compression joint for 795 Arbutus conductor, the complete catalog number is:

CJE11

Notes:

1. Installation Instructions for Compression Joints are on page 268.
2. For more information on die selection and ordering instructions, see Tools and Equipment tab in this catalog.

CATALOG NUMBER	CONDUCTOR				DIE SIZE	TOTAL WEIGHT		DIMENSION L	
	CODE NAME	SIZE	STRANDING	DIAMETER		LBS	KG	IN	MM
		KCMIL		IN					
CJE07	Peony	300.0	19	0.629	07CD	0.3	0.13	5.6	142
CJE07	Tulip	336.4	19	0.666	07CD	0.3	0.13	5.6	142
CJE07	Daffodil	350.0	19	0.679	07CD	0.3	0.13	5.6	142
CJE08	Canna	397.5	19	0.724	08CD	0.4	0.20	6.4	163
CJE09	Goldentuft	450.0	19	0.770	09CD	0.6	0.28	7.2	183
CJE09	Cosmos	477.0	19	0.793	09CD	0.6	0.28	7.2	183
CJE09	Zinnia	500.0	19	0.811	09CD	0.6	0.28	7.2	183
CJE10	Dahlia	556.5	19	0.856	10CD	0.9	0.39	8.0	203
CJE10	Meadowsweet	600.0	37	0.891	10CD	0.9	0.39	8.0	203
CJE10	Orchid	636.0	37	0.918	10CD	0.9	0.39	8.0	203
CJE10	Heuchera	650.0	37	0.928	10CD	0.9	0.39	8.0	203
CJE11	Verbena	700.0	37	0.963	11CD	1.1	0.50	8.8	224
CJE11	Violet	715.5	37	0.974	11CD	1.1	0.50	8.8	224
CJE11	Petunia	750.0	37	0.997	11CD	1.1	0.50	8.8	224
CJE11	Arbutus	795.0	37	1.026	11CD	1.1	0.50	8.8	224
CJE11	—	800.0	61	1.031	11CD	1.1	0.50	8.8	224
CJE12	Cockscomb	900.0	37	1.092	12CD	1.5	0.68	9.6	244
CJE12	Magnolia	964.0	37	1.124	12CD	1.5	0.68	9.6	244

Quick Compress Compression Joints for AAC Conductor, CJE Series (cont.)

CATALOG NUMBER	CONDUCTOR				DIE SIZE	TOTAL WEIGHT		DIMENSION L	
	CODE NAME	SIZE	STRANDING	DIAMETER		LBS	KG	IN	MM
		KCMIL		IN					
CJE12	Magnolia	954.0	37	1.124	12CD	1.5	0.68	9.6	244
CJE13	Hawkweed	1000.0	37	1.151	13CD	1.8	0.82	10.4	264
CJE13	Bluebell	1033.5	37	1.170	13CD	1.8	0.82	10.4	264
CJE13	Marigold	1113.0	61	1.216	13CD	1.8	0.82	10.4	264
CJE14	Hawthorn	1192.5	61	1.258	14CD	2.3	1.04	11.2	284
CJE14	—	1250.0	91	1.289	14CD	2.3	1.04	11.2	284
CJE14	Narcissus	1272.0	61	1.300	14CD	2.3	1.04	11.2	284
CJE14	—	1300.0	91	1.315	14CD	2.3	1.04	11.2	284
CJE15	Columbine	1351.5	61	1.340	15CD	2.8	1.27	12.0	305
CJE15	Carnation	1431.0	61	1.379	15CD	2.8	1.27	12.0	305
CJE15	—	1500.0	91	1.412	15CD	2.8	1.27	12.0	305
CJE15	Gladiolus	1510.5	61	1.417	15CD	2.8	1.27	12.0	305
CJE16	Coreopsis	1590.0	61	1.454	16CD	3.4	1.54	12.8	325
CJE17	Jessamine	1750.0	61	1.525	17CD	4.1	1.86	13.6	345
CJE18	Cowslip	2000.0	91	1.630	18CD	4.9	2.22	14.4	366
CJE19	Sagebrush	2250.0	91	1.729	19CD	5.7	2.59	15.2	386
CJE19	—	2300.0	91	1.750	19CD	5.7	2.59	15.2	386
CJE20	Lupine	2500.0	91	1.823	20CD	6.7	3.04	16.0	406

Quick Compress Replacement Compression Joints for AAC Conductor, CJER Series

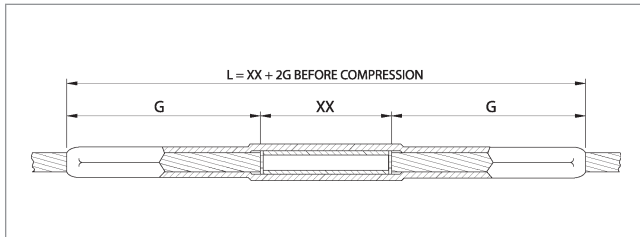

The Quick Compress Replacement Joints are used to replace damaged conductor in midspan. They are designed for fast and easy installation. By using a high strength alloy, the compression length has been shortened for less compression bites, while maintaining a minimum 95% of the ASTM rated strength. The replacement joint is pre-filled, eliminating an installation step.

The end tapers of all compression accessories are supplied with a high voltage finish for die size sections 12CD and above.

Ordering Instructions

Step 1: Assembly Catalog Number

Determine the assembly catalog number based on the conductor being used.

Step 2: Determine Length of Conductor Removed (XX)

Determine the length of conductor (XX) that will be cut out, to the nearest inch (Maximum 48").

Step 3: Assemble Catalog Number

Catalog Number + **Removed Conductor Length (XX)**

Example:

A replacement compression joint for 795 Arbutus conductor with a removed conductor length of 24 inches, the complete catalog number is:

CJE110R24

Notes:

1. Installation Instructions for Compression Joints are on page 268.
2. For more information on die selection and ordering instructions, see Tools and Equipment tab in this catalog.

CATALOG NUMBER	CONDUCTOR				DIE SIZE	DIMENSION G	
	CODE WORD	SIZE	STRANDING	DIAMETER		IN	MM
		KCMIL	AL	IN			
CJE070RXX	Peony	300.6	19	0.629	07CD	7.6	192
CJE070RXX	Tulip	336.4	19	0.666	07CD	7.6	192
CJE070RXX	Daffodil	350.0	19	0.679	07CD	7.6	192
CJE080RXX	Canna	397.5	19	0.724	08CD	8.4	212
CJE090RXX	Goldentuft	450.0	19	0.770	09CD	9.2	233
CJE090RXX	Cosmos	477.0	19	0.793	09CD	9.2	233
CJE090RXX	Zinnia	500.0	19	0.811	09CD	9.2	233
CJE100RXX	Dahlia	556.5	19	0.856	10CD	10.0	253
CJE100RXX	Meadowsweet	600.0	37	0.891	10CD	10.0	253
CJE100RXX	Orchid	636.0	37	0.918	10CD	10.0	253
CJE100RXX	Heuchera	650.0	37	0.928	10CD	10.0	253
CJE110RXX	Verbena	700.0	37	0.963	11CD	10.8	273
CJE110RXX	Violet	715.5	37	0.974	11CD	10.8	273
CJE110RXX	Petunia	750.0	37	0.997	11CD	10.8	273
CJE110RXX	Arbutus	795.0	37	1.026	11CD	10.8	273
CJE110RXX	—	800.0	61	1.031	11CD	10.8	273
CJE120RXX	Cockscomb	900.0	37	1.092	12CD	11.6	294

Quick Compress Replacement Compression Joints for AAC Conductor, CJER Series (cont.)

CATALOG NUMBER	CONDUCTOR				DIE SIZE	DIMENSION G	
	CODE WORD	SIZE	STRANDING	DIAMETER		IN	MM
		KCMIL	AL	IN			
CJE120RXX	Magnolia	954.0	37	1.124	12CD	11.8	294
CJE130RXX	Hawkweed	1000.0	37	1.151	13CD	12.4	314
CJE130RXX	Bluebell	1033.5	37	1.170	13CD	12.4	314
CJE130RXX	Marigold	1113.0	61	1.216	13CD	12.4	314
CJE140RXX	Hawthorn	1192.5	61	1.258	14CD	13.2	334
CJE140RXX	—	1250.0	91	1.289	14CD	13.2	334
CJE140RXX	Narcissus	1272.0	61	1.300	14CD	13.2	334
CJE140RXX	—	1300.0	91	1.315	14CD	13.2	334
CJE150RXX	Columbine	1351.5	61	1.340	15CD	14.0	355
CJE150RXX	Carnation	1431.0	61	1.379	15CD	14.0	355
CJE150RXX	—	1500.0	91	1.412	15CD	14.0	355
CJE150RXX	Gladiolus	1510.5	61	1.417	15CD	14.0	355
CJE160RXX	Coreopsis	1590.0	61	1.454	16CD	14.8	375
CJE170RXX	Jessamine	1750.0	61	1.525	17CD	15.6	395
CJE180RXX	Cowslip	2000.0	91	1.630	18CD	16.4	416
CJE190RXX	Sagebrush	2250.0	91	1.729	19CD	17.2	436
CJE190RXX	—	2300.0	—	1.750	19CD	17.2	436
CJE200RXX	Lupine	2500.0	91	1.823	20CD	18.0	456

Quick Compress Repair Sleeve for AAC Conductor, RS Series

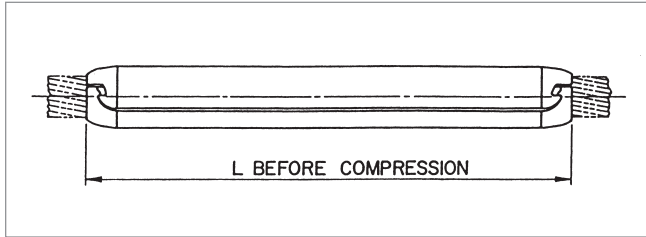

The Quick Compress Repair Sleeve is designed for ACSR, AAC, AAAC and ACAR conductors. The repair sleeve incorporates an improved design of interlocking extrusions, providing a permanent grip on the conductor when compressed.

The repair sleeve will restore the conductor to 95% of its ASTM rated strength where up to one-third of the aluminum strands are damaged.

Ordering Instructions

Step 1: Assembly Catalog Number

Determine the assembly catalog number based on the conductor being used.

Example:

A repair sleeve for 795 Arbutus conductor, the complete catalog number is:

RS11

Notes:

1. Installation Instructions for Compression Joints are on page 270.
2. For more information on die selection and ordering instructions, see the AFL Tool Catalog.

AFL NO.	CONDUCTOR				DIE SIZE	TOTAL WEIGHT		DIMENSION L	
	CODE WORD	SIZE	STRANDING	DIAMETER		LBS	KG	IN	MM
		KCMIL		IN					
RS07	Peony	300.0	19	0.629	07CD	0.4	0.17	8.4	213
RS07	Tulip	336.4	19	0.666	07CD	0.4	0.17	8.4	213
RS07	Daffodil	350.0	19	0.679	07CD	0.4	0.17	8.4	213
RS08	Canna	397.5	19	0.724	08CD	0.6	0.26	9.6	244
RS09	Goldentuft	450.0	19	0.770	09CD	0.8	0.38	10.8	274
RS09	Cosmos	477.0	19	0.793	09CD	0.8	0.38	10.8	274
RS09	Zinnia	500.0	19	0.811	09CD	0.8	0.38	10.8	274
RS10	Dahlia	556.5	19	0.856	10CD	1.1	0.50	12.0	305
RS10	Meadowsweet	600.0	37	0.891	10CD	1.1	0.50	12.0	305
RS10	Orchid	636.0	37	0.918	10CD	1.1	0.50	12.0	305
RS10	Heuchera	650.0	37	0.928	10CD	1.1	0.50	12.0	305
RS11	Verbena	700.0	37	0.963	11CD	1.5	0.68	13.2	335
RS11	Violet	715.5	37	0.974	11CD	1.5	0.68	13.2	335
RS11	Petunia	750.0	37	0.997	11CD	1.5	0.68	13.2	335
RS11	Arbutus	795.0	37	1.026	11CD	1.5	0.68	13.2	335
RS11	—	800.0	61	1.031	11CD	1.5	0.68	13.2	335
RS12	Cockscomb	900.0	37	1.092	12CD	1.9	0.86	14.4	366
RS12	Magnolia	954.0	37	1.124	12CD	1.9	0.86	14.4	366

Quick Compress Repair Sleeve for AAC Conductor, RS Series (cont.)

AFL NO.	CONDUCTOR				DIE SIZE	TOTAL WEIGHT		DIMENSION L	
	CODE WORD	SIZE	STRANDING	DIAMETER		LBS	KG	IN	MM
		KCMIL		IN					
RS13	Hawkweed	1000.0	37	1.151	13CD	2.4	1.09	15.6	396
RS13	Bluebell	1033.5	37	1.170	13CD	2.4	1.09	15.6	396
RS13	Marigold	1113.0	61	1.216	13CD	2.4	1.09	15.6	396
RS14	Hawthorn	1192.5	61	1.258	14CD	3.1	1.41	16.8	427
RS14	—	1250.0	91	1.289	14CD	3.1	1.41	16.8	427
RS14	Narcissus	1272.0	61	1.300	14CD	3.1	1.41	16.8	427
RS14	—	1300.0	91	1.315	14CD	3.1	1.41	16.8	427
RS15	Columbine	1351.5	61	1.340	15CD	3.8	1.72	18.0	457
RS15	Carnation	1431.0	61	1.379	15CD	3.8	1.72	18.0	457
RS15	—	1500.0	91	1.412	15CD	3.8	1.72	18.0	457
RS15	Gladiolus	1510.5	61	1.417	15CD	3.8	1.72	18.0	457
RS16	Coreopsis	1590.0	61	1.454	16CD	4.6	2.09	19.2	488
RS17	Jessamine	1750.0	61	1.525	17CD	5.5	2.49	20.4	518
RS18	Cowslip	2000.0	91	1.630	18CD	6.6	2.99	21.6	549
RS19	Sagebrush	2250.0	91	1.729	19CD	7.8	3.54	22.8	579
RS19	—	2300.0	91	1.750	19CD	7.8	3.54	22.8	579
RS20	Lupine	2500.0	91	1.823	20CD	9.1	4.13	24.0	610

Quick Compress Jumper Connector for AAC Conductor, JC Series

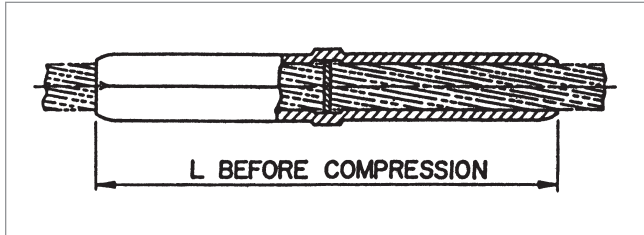

The Quick Compress Jumper Connector is designed for fast and easy installation. By using a high strength alloy, the compression length has been shortened for less compression bites. The jumper connector is pre-filled, eliminating an installation step. Each jumper connector has a center stop, making it easy to center the jumper on the conductor.

All Quick Compress Jumper Connectors are designed for limited tension use, maintaining a minimum of 40% of the ASTM rated strength of the conductor.

The end tapers of all compression accessories are supplied with a High Voltage finish for die size sections 12CD and above.

Ordering Instructions

Step 1: Assembly Catalog Number

Determine the assembly catalog number based on the conductor being used.

Example:

A jumper connector for 795 Arbutus conductor, the complete catalog number is:

JC11

Notes:

1. Installation Instructions for Jumpers are on page 271.
2. For more information on die selection and ordering instructions, see Tools and Equipment tab in this catalog.

CATALOG NUMBER	CONDUCTOR				DIE SIZE	TOTAL WEIGHT		DIMENSION L	
	CODE WORD	SIZE	STRANDING	DIAMETER		LBS	KG	IN	MM
		KCMIL		IN					
JC07	Peony	300.6	19	0.629	07CD	0.3	0.12	5.6	142
JC07	Tulip	336.4	19	0.666	07CD	0.3	0.12	5.6	142
JC07	Daffodil	350.0	19	0.679	07CD	0.3	0.12	5.6	142
JC08	Canna	397.5	19	0.724	08CD	0.4	0.19	6.4	163
JC09	Goldentuft	450.0	19	0.770	09CD	0.6	0.27	7.2	183
JC09	Cosmos	477.0	19	0.793	09CD	0.6	0.27	7.2	183
JC09	Zinnia	500.0	19	0.811	09CD	0.6	0.27	7.2	183
JC10	Dahlia	556.5	19	0.856	10CD	0.8	0.37	8.0	203
JC10	Meadowsweet	600.0	37	0.891	10CD	0.8	0.37	8.0	203
JC10	Orchid	636.0	37	0.918	10CD	0.8	0.37	8.0	203
JC10	Heuchera	650.0	37	0.928	10CD	0.8	0.37	8.0	203
JC11	Verbena	700.0	37	0.963	11CD	1.1	0.50	8.8	224
JC11	Violet	715.5	37	0.974	11CD	1.1	0.50	8.8	224
JC11	Petunia	750.0	37	0.997	11CD	1.1	0.50	8.8	224
JC11	Arbutus	795.0	37	1.026	11CD	1.1	0.50	8.8	224
JC11	—	800.0	61	1.031	11CD	1.1	0.50	8.8	224

Quick Compress Jumper Connector for AAC Conductor, JC Series (cont.)

CATALOG NUMBER	CONDUCTOR				DIE SIZE	TOTAL WEIGHT		DIMENSION L	
	CODE WORD	SIZE	STRANDING	DIAMETER		LBS	KG	IN	MM
		KCMIL		IN					
JC12	Cockscomb	900.0	37	1.092	12CD	1.4	0.64	9.6	244
JC12	Magnolia	954.0	37	1.124	12CD	1.4	0.64	9.6	244
JC13	Hawkweed	1000.0	37	1.151	13CD	1.7	0.77	10.4	264
JC13	Bluebell	1033.5	37	1.170	13CD	1.7	0.77	10.4	264
JC13	Marigold	1113.0	61	1.216	13CD	1.7	0.77	10.4	264
JC14	Hawthorn	1192.5	61	1.258	14CD	2.2	1.00	11.2	284
JC14	—	1250.0	91	1.289	14CD	2.2	1.00	11.2	284
JC14	Narcissus	1272.0	61	1.300	14CD	2.2	1.00	11.2	284
JC14	—	1300.0	91	1.315	14CD	2.2	1.00	11.2	284
JC15	Columbine	1351.5	61	1.340	15CD	2.7	1.22	12.0	305
JC15	Carnation	1431.0	61	1.379	15CD	2.7	1.22	12.0	305
JC15	—	1500.0	91	1.412	15CD	2.7	1.22	12.0	305
JC15	Gladiolus	1510.5	61	1.417	15CD	2.7	1.22	12.0	305
JC16	Coreopsis	1590.0	61	1.454	16CD	3.3	1.50	12.8	325
JC17	Jessamine	1750.0	61	1.525	17CD	3.9	1.77	13.6	345
JC18	Cowslip	2000.0	91	1.630	18CD	4.7	2.13	14.4	366
JC19	Sagebrush	2250.0	91	1.729	19CD	5.4	2.45	15.2	386
JC19	—	2300.0	91	1.750	19CD	5.4	2.45	15.2	386
JC20	Lupine	2500.0	91	1.823	20CD	6.4	2.90	16.0	406

Quick Compress Terminal for AAC Conductor, Straight, TS Series

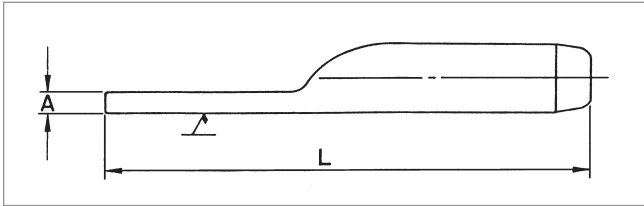

The TS Series Straight Terminal Connector is designed for fast and easy installation. By using a high strength alloy, the compression length has been shortened for less compression bites. The terminal connector is pre-filled, eliminating an installation step.

All TS Series connectors are designed for limited tension use, maintaining a minimum of 40% of the ASTM rated strength of the conductor.

The end tapers of all compression accessories are supplied with a High Voltage finish for die size sections 12CD and above.

The square edges of bolted pads of the compression accessories could cause Corona. Pads with edges and corners rounded can be supplied by adding the catalog suffix 'EHV'.

Ordering Instructions

Step 1: Catalog Number

Determine the catalog number based on the conductor being used.

Step 2: Extra High Voltage Finish

For Extra High Voltage Finish, use 'EHV'. (≥ 345 kV)

For Standard Finish, leave blank. (< 345 kV)

Step 3: Assemble Catalog Number.



Example:

A straight terminal for 795 Arbutus with an EHV finish, the complete catalog number is:

TS11EHV

Notes:

1. Pad Dimensions are on page 257.
2. Installation Instructions for Terminals are on page 272.
3. Bolts, nuts and washers are not supplied with TS Series Terminal Connectors.
4. For more information on die selection and ordering instructions, see Tools and Equipment tab in this catalog.

Quick Compress Terminal for AAC Conductor, Straight, TS Series (cont.)

CATALOG NUMBER	CONDUCTOR				DIE SIZE	TOTAL WEIGHT		DIMENSION				PAD SIZE
	CODE WORD	SIZE	STRANDING	DIAMETER		LBS	KG	A		L		
		KCMIL	AL	IN				IN	MM	IN	MM	
TS07	Peony	300.0	19	0.629	07CD	0.5	0.20	0.3	8	9.0	229	B
TS07	Tulip	336.4	19	0.666	07CD	0.5	0.20	0.3	8	9.0	229	B
TS07	Daffodil	350.0	19	0.679	07CD	0.5	0.20	0.3	8	9.0	229	B
TS08	Canna	397.5	19	0.724	08CD	0.6	0.28	0.4	10	9.6	244	B
TS09	Goldentuft	450.0	19	0.770	09CD	0.8	0.38	0.4	11	10.0	254	B
TS09	Cosmos	477.0	19	0.793	09CD	0.8	0.38	0.4	11	10.0	254	B
TS09	Zinnia	500.0	19	0.811	09CD	0.8	0.38	0.4	11	10.0	254	B
TS10	Dahlia	556.5	19	0.856	10CD	1.1	0.50	0.5	12	10.6	269	B
TS10	Meadowsweet	600.0	37	0.891	10CD	1.1	0.50	0.5	12	10.6	269	B
TS10	Orchid	636.0	37	0.918	10CD	1.1	0.50	0.5	12	10.6	269	B
TS10	Heuchera	650.0	37	0.928	10CD	1.1	0.50	0.5	12	10.6	269	B
TS11	Verbena	700.0	37	0.963	11CD	1.5	0.68	0.4	9	11.7	297	D
TS11	Violet	715.5	37	0.974	11CD	1.5	0.68	0.4	9	11.7	297	D
TS11	Petunia	750.0	37	0.997	11CD	1.5	0.68	0.4	9	11.7	297	D
TS11	Arbutus	795.0	37	1.026	11CD	1.5	0.68	0.4	9	11.7	297	D
TS11	—	800.0	61	1.031	11CD	1.5	0.68	0.4	9	11.7	297	D
TS12	Cockscomb	900.0	37	1.092	12CD	1.8	0.82	0.4	11	12.1	307	D
TS12	Magnolia	954.0	37	1.124	12CD	1.8	0.82	0.4	11	12.1	307	D
TS13	Hawkweed	1000.0	37	1.151	13CD	2.1	0.95	0.5	13	12.8	325	D
TS13	Bluebell	1033.5	37	1.170	13CD	2.1	0.95	0.5	13	12.8	325	D
TS13	Marigold	1113.0	61	1.216	13CD	2.1	0.95	0.5	13	12.8	325	D
TS14	Hawthorn	1192.5	61	1.258	14CD	2.7	1.22	0.6	16	13.8	351	D
TS14	—	1250.0	91	1.289	14CD	2.7	1.22	0.6	16	13.8	351	D
TS14	Narcissus	1272.0	61	1.300	14CD	2.7	1.22	0.6	16	13.8	351	D
TS14	—	1300.0	91	1.315	14CD	2.7	1.22	0.6	16	13.8	351	D
TS15	Columbine	1351.5	61	1.340	15CD	3.3	1.50	0.7	17	14.3	363	D
TS15	Carnation	1431.0	61	1.379	15CD	3.3	1.50	0.7	17	14.3	363	D
TS15	—	1500.0	91	1.412	15CD	3.3	1.50	0.7	17	14.3	363	D
TS15	Gladiolus	1510.5	61	1.417	15CD	3.3	1.50	0.7	17	14.3	363	D
TS16	Coreopsis	1590.0	61	1.454	16CD	3.8	1.72	0.7	17	14.6	371	D
TS17	Jessamine	1750.0	61	1.525	17CD	0.5	2.13	0.7	17	16.3	414	E
TS18	Cowslip	2000.0	91	1.630	18CD	5.5	2.49	0.7	19	16.8	427	E
TS19	Sagebrush	2250.0	91	1.729	19CD	6.5	2.95	0.9	22	17.5	445	E
TS19	—	2300.0	91	1.750	19CD	6.5	2.95	0.9	22	17.5	445	E
TS20	Lupine	2500.0	91	1.823	20CD	7.3	3.31	0.9	22	12.9	455	E

Quick Compress Terminal for AAC Conductor, 15°, TF Series

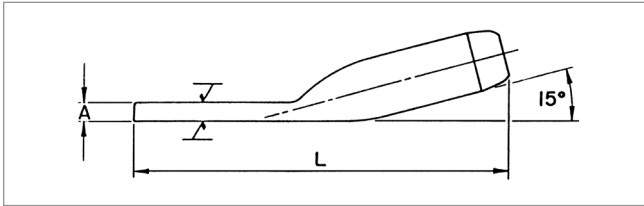

The TF Series 15° Terminal Connector is designed for fast and easy installation. By using a high strength alloy, the compression length has been shortened for less compression bites. The terminal connector is pre-filled, eliminating an installation step.

When used with the Quick Compress dead end, the TF Series connectors can be bolted in either straight or 30° position. All TF Series connectors are designed for limited tension use, maintaining a minimum of 40% of the ASTM rated strength of the conductor.

The end tapers of all compression accessories are supplied with a High Voltage finish for die size sections 12CD and above.

The square edges of bolted pads of the compression accessories could cause Corona. Pads with edges and corners rounded can be supplied by adding the catalog suffix 'EHV'.

Ordering Instructions

Step 1: Catalog Number

Determine the catalog number based on the conductor being used.

Step 2: Extra High Voltage Finish

For Extra High Voltage Finish, use 'EHV'. (≥ 345 kV)

For Standard Finish, leave blank. (< 345 kV)

Step 3: Assemble Catalog Number.

Catalog Number	+	EHV Finish
-------------------	---	---------------

Example:

A 15° terminal for 795 Arbutus with an EHV finish, the complete catalog number is:

TF11EHV

Notes:

1. Pad Dimensions are on page 257.
2. Installation Instructions for Terminals are on page 272.
3. Bolts, nuts and washers are supplied with TF Series Terminal Connectors.
4. For more information on die selection and ordering instructions, see Tools and Equipment tab in this catalog.

Quick Compress Terminal for AAC Conductor, 15°, TF Series (cont.)

CATALOG NUMBER	CONDUCTOR				DIE SIZE	TOTAL WEIGHT		DIMENSIONS				PAD SIZE
	CODE WORD	SIZE	STRANDING	DIAMETER		LBS	KG	A		L		
		KCMIL	AL/ST	IN				IN	MM	IN	MM	
TF07	Peony	300.6	19	0.629	07CD	0.5	0.24	0.3	8	7.8	196	B
TF07	Tulip	336.4	19	0.666	07CD	0.5	0.24	0.3	8	7.8	196	B
TF07	Daffodil	350.0	19	0.679	07CD	0.5	0.24	0.3	8	7.8	196	B
TF08	Canna	397.5	19	0.724	08CD	0.7	0.31	0.4	10	8.3	211	B
TF09	Goldentuft	450.0	19	0.770	09CD	0.9	0.40	0.4	11	8.9	226	B
TF09	Cosmos	477.0	19	0.793	09CD	0.9	0.40	0.4	11	8.9	226	B
TF09	Zinnia	500.0	19	0.811	09CD	0.9	0.40	0.4	11	8.9	226	B
TF10	Dahlia	556.5	19	0.856	10CD	1.1	0.50	0.5	12	9.4	239	B
TF10	Meadowsweet	600.0	37	0.891	10CD	1.1	0.50	0.5	12	9.4	239	B
TF10	Orchid	636.0	37	0.918	10CD	1.1	0.50	0.5	12	9.4	239	B
TF10	Heuchera	650.0	37	0.928	10CD	1.1	0.50	0.5	12	9.4	239	B
TF11	Verbena	700.0	37	0.963	11CD	1.5	0.68	0.4	9	10.4	264	D
TF11	Violet	715.5	37	0.974	11CD	1.5	0.68	0.4	9	10.4	264	D
TF11	Petunia	750.0	37	0.997	11CD	1.5	0.68	0.4	9	10.4	264	D
TF11	Arbutus	795.0	37	1.026	11CD	1.5	0.68	0.4	9	10.4	264	D
TF11	—	800.0	61	1.031	11CD	1.5	0.68	0.4	9	10.4	264	D
TF12	Cockscomb	900.0	37	1.092	12CD	1.9	0.86	0.4	11	11.0	279	D
TF12	Magnolia	954.0	37	1.124	12CD	1.9	0.86	0.4	11	11.0	279	D
TF13	Hawkweed	1000.0	37	1.151	13CD	2.2	1.00	0.5	13	11.2	284	D
TF13	Bluebell	1033.5	37	1.170	13CD	2.2	1.00	0.5	13	11.2	284	D
TF13	Marigold	1113.0	61	1.216	13CD	2.2	1.00	0.5	13	11.2	284	D
TF14	Hawthorn	1192.5	61	1.258	14CD	2.8	1.27	0.6	16	12.0	305	D
TF14	—	1250.0	91	1.289	14CD	2.8	1.27	0.6	16	12.0	305	D
TF14	Narcissus	1272.0	61	1.300	14CD	2.8	1.27	0.6	16	12.0	305	D
TF14	—	1300.0	91	1.315	14CD	2.8	1.27	0.6	16	12.0	305	D
TF15	Columbine	1351.5	61	1.340	15CD	3.2	1.45	0.7	17	12.5	318	D
TF15	Carnation	1431.0	61	1.379	15CD	3.2	1.45	0.7	17	12.5	318	D
TF15	—	1500.0	91	1.412	15CD	3.2	1.45	0.7	17	12.5	318	D
TF15	Gladiolus	1510.5	61	1.417	15CD	3.2	1.45	0.7	17	12.5	318	D
TF16	Coreopsis	1590.0	61	1.454	16CD	3.7	1.69	0.9	17	13.3	338	D
TF17	Jessamine	1750.0	61	1.525	17CD	4.6	2.09	0.7	17	14.4	366	E
TF18	Cowslip	2000.0	91	1.630	18CD	5.2	2.36	0.7	19	15.0	381	E
TF19	Sagebrush	2250.0	91	1.729	19CD	6.3	2.86	0.9	22	15.7	399	E
TF19	—	2300.0	91	1.750	19CD	6.3	2.86	0.9	22	15.7	399	E
TF20	Lupine	2500.0	91	1.823	20CD	6.8	3.08	0.9	22	16.0	406	E

Quick Compress Terminal for AAC Conductor, 45°, T45 Series

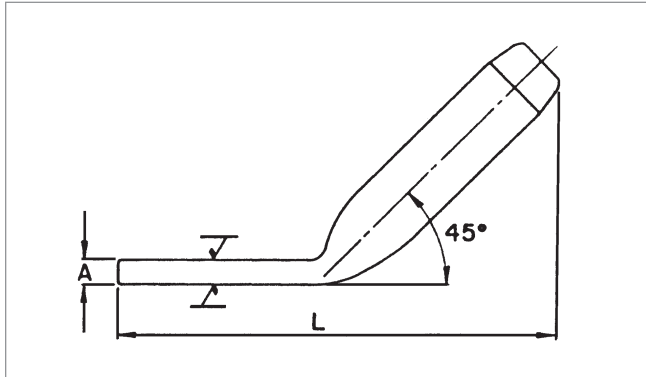

The T45 Series 45° Terminal Connector is designed for fast and easy installation. By using a high strength alloy, the compression length has been shortened for less compression bites. The terminal connector is pre-filled, eliminating an installation step.

All T45 Series connectors are designed for limited tension use, maintaining a minimum of 40% of the ASTM rated strength of the conductor.

The end tapers of all compression accessories are supplied with a High Voltage finish for die size sections 12CD and above.

The square edges of bolted pads of the compression accessories could cause Corona. Pads with edges and corners rounded can be supplied by adding the catalog suffix 'EHV'.

Ordering Instructions

Step 1: Catalog Number

Determine the catalog number based on the conductor being used.

Step 2: Extra High Voltage Finish

For Extra High Voltage Finish, use 'EHV'. (≥ 345 kV)

For Standard Finish, leave blank. (< 345 kV)

Step 3: Assemble Catalog Number.

Catalog Number	+	EHV Finish
----------------	---	------------

Example:

A 45° terminal for 795 Arbutus with an EHV finish, the complete catalog number is:

T4511EHV

Notes:

1. Pad Dimensions are on page 257.
2. Installation Instructions for Terminals are on page 272.
3. Bolts, nuts and washers are not supplied with T45 Series Terminal Connectors.
4. For more information on die selection and ordering instructions, see Tools and Equipment tab in this catalog.

Quick Compress Terminal for AAC Conductor, 45°, T45 Series (cont.)

CATALOG NUMBER	CONDUCTOR				DIE SIZE	TOTAL WEIGHT		DIMENSIONS				PAD SIZE
	CODE WORD	SIZE	STRANDING	DIAMETER		LBS	KG	A		L		
		KCMIL	AL/ST	IN				IN	MM	IN	MM	
T4507	Peony	300.6	19	0.629	07CD	0.4	0.19	0.3	8	7.3	185	B
T4507	Tulip	336.4	19	0.666	07CD	0.4	0.19	0.3	8	7.3	185	B
T4507	Daffodil	350.0	19	0.679	07CD	0.4	0.19	0.3	8	7.3	185	B
T4508	Canna	397.5	19	0.724	08CD	0.6	0.25	0.4	10	7.8	198	B
T4509	Goldentuft	450.0	19	0.770	09CD	0.8	0.34	0.4	11	8.2	208	B
T4509	Cosmos	477.0	19	0.793	09CD	0.8	0.34	0.4	11	8.2	208	B
T4509	Zinnia	500.0	19	0.811	09CD	0.8	0.34	0.4	11	8.2	208	B
T4510	Dahlia	556.5	19	0.856	10CD	1.0	0.45	0.5	12	8.6	218	B
T4510	Meadowsweet	600.0	37	0.891	10CD	1.0	0.45	0.5	12	8.6	218	B
T4510	Orchid	636.0	37	0.918	10CD	1.0	0.45	0.5	12	8.6	218	B
T4510	Heuchera	650.0	37	0.928	10CD	1.0	0.45	0.5	12	8.6	218	B
T4511	Verbena	700.0	37	0.963	11CD	1.3	0.59	0.4	9	9.4	239	D
T4511	Violet	715.5	37	0.974	11CD	1.3	0.59	0.4	9	9.4	239	D
T4511	Petunia	750.0	37	0.997	11CD	1.3	0.59	0.4	9	9.4	239	D
T4511	Arbutus	795.0	37	1.026	11CD	1.3	0.59	0.4	9	9.4	239	D
T4511	—	800.0	61	1.031	11CD	1.3	0.59	0.4	9	9.4	239	D
T4512	Cockscomb	900.0	37	1.092	12CD	1.6	0.73	0.4	11	9.7	246	D
T4512	Magnolia	954.0	37	1.124	12CD	1.6	0.73	0.4	11	9.7	246	D
T4513	Hawkweed	1000.0	37	1.151	13CD	2.0	0.91	0.5	13	10.2	259	D
T4513	Bluebell	1033.5	37	1.170	13CD	2.0	0.91	0.5	13	10.2	259	D
T4513	Marigold	1113.0	61	1.216	13CD	2.0	0.91	0.5	13	10.2	259	D
T4514	Hawthorn	1192.5	61	1.258	14CD	2.3	1.04	0.6	16	10.6	269	D
T4514	—	1250.0	91	1.289	14CD	2.3	1.04	0.6	16	10.6	269	D
T4514	Narcissus	1272.0	61	1.300	14CD	2.3	1.04	0.6	16	10.6	269	D
T4514	—	1300.0	91	1.315	14CD	2.3	1.04	0.6	16	10.6	269	D
T4515	Columbine	1351.5	61	1.340	15CD	2.8	1.27	0.7	17	11.8	300	D
T4515	Carnation	1431.0	61	1.379	15CD	2.8	1.27	0.7	17	11.8	300	D
T4515	—	1500.0	91	1.412	15CD	2.8	1.27	0.7	17	11.8	300	D
T4515	Gladiolus	1510.5	61	1.417	15CD	2.8	1.27	0.7	17	11.8	300	D
T4516	Coreopsis	1590.0	61	1.454	16CD	3.4	1.54	0.7	17	11.0	279	D
T4517	Jessamine	1750.0	61	1.525	17CD	4.2	1.91	0.7	17	12.6	320	E
T4518	Cowslip	2000.0	91	1.630	18CD	4.9	2.22	0.7	19	13.0	330	E
T4519	Sagebrush	2250.0	91	1.729	19CD	5.7	2.59	0.9	22	13.7	348	E
T4519	—	2300.0	91	1.750	19CD	5.7	2.59	0.9	22	13.7	348	E
T4520	Lupine	2500.0	91	1.823	20CD	6.5	2.95	0.9	22	14.2	361	E

Quick Compress Terminal for AAC Conductor, 90°, TN Series

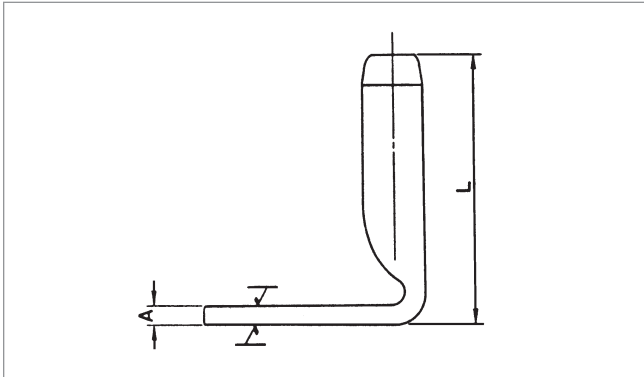

The TN Series 90° Terminal Connector is designed for fast and easy installation. By using a high strength alloy, the compression length has been shortened for less compression bites. The terminal connector is pre-filled, eliminating an installation step.

All TN Series connectors are designed for limited tension use, maintaining a minimum of 40% of the ASTM rated strength of the conductor.

The end tapers of all compression accessories are supplied with a High Voltage finish for die size sections 12CD and above.

The square edges of bolted pads of the compression accessories could cause Corona. Pads with edges and corners rounded can be supplied by adding the catalog suffix 'EHV'.

Ordering Instructions

Step 1: Catalog Number

Determine the catalog number based on the conductor being used.

Step 2: Extra High Voltage Finish

For Extra High Voltage Finish, use 'EHV'. (≥ 345 kV)

For Standard Finish, leave blank. (< 345 kV)

Step 3: Assemble Catalog Number.



Example:

A 90° terminal for 795 Arbutus with an EHV finish, the complete catalog number is:

TN11EHV

Notes:

1. Pad Dimensions are on page 257.
2. Installation Instructions for Terminals are on page 272.
3. Bolts, nuts and washers are not supplied with TN Series Terminal Connectors.
4. For more information on die selection and ordering instructions, see Tools and Equipment tab in this catalog.

Quick Compress Terminal for AAC Conductor, 90°, TN Series (cont.)

CATALOG NUMBER	CONDUCTOR				DIE SIZE	TOTAL WEIGHT		DIMENSIONS				PAD SIZE
	CODE WORD	SIZE	STRANDING	DIAMETER		LBS	KG	A		L		
		KCMIL	AL	IN				IN	MM	IN	MM	
TN07	Peony	300.6	19	0.629	07CD	0.5	0.20	0.3	8	5.2	132	B
TN07	Tulip	336.4	19	0.666	07CD	0.5	0.20	0.3	8	5.2	132	B
TN07	Daffodil	350.0	19	0.679	07CD	0.5	0.20	0.3	8	5.2	132	B
TN08	Canna	397.5	19	0.724	08CD	0.6	0.29	0.4	10	5.7	145	B
TN09	Goldentuft	450.0	19	0.770	09CD	0.8	0.38	0.4	11	6.2	157	B
TN09	Cosmos	477.0	19	0.793	09CD	0.8	0.38	0.4	11	6.2	157	B
TN09	Zinnia	500.0	19	0.811	09CD	0.8	0.38	0.4	11	6.2	157	B
TN10	Dahlia	556.5	19	0.856	10CD	1.1	0.50	0.5	12	6.7	170	B
TN10	Meadowsweet	600.0	37	0.891	10CD	1.1	0.50	0.5	12	6.7	170	B
TN10	Orchid	636.0	37	0.918	10CD	1.1	0.50	0.5	12	6.7	170	B
TN10	Heuchera	650.0	37	0.928	10CD	1.1	0.50	0.5	12	6.7	170	B
TN11	Verbena	700.0	37	0.963	11CD	1.4	0.64	0.4	9	7.5	191	D
TN11	Violet	715.5	37	0.974	11CD	1.4	0.64	0.4	9	7.5	191	D
TN11	Petunia	750.0	37	0.997	11CD	1.4	0.64	0.4	9	7.5	191	D
TN11	Arbutus	795.0	37	1.026	11CD	1.4	0.64	0.4	9	7.5	191	D
TN11	—	800.0	61	1.031	11CD	1.4	0.64	0.4	9	7.5	191	D
TN12	Cockscomb	900.0	37	1.092	12CD	1.8	0.82	0.4	11	7.9	202	D
TN12	Magnolia	954.0	37	1.124	12CD	1.8	0.82	0.4	11	7.9	202	D
TN13	Hawkweed	1000.0	37	1.151	13CD	2.2	1.00	0.5	13	8.5	216	D
TN13	Bluebell	1033.5	37	1.170	13CD	2.2	1.00	0.5	13	8.5	216	D
TN13	Marigold	1113.0	61	1.216	13CD	2.2	1.00	0.5	13	8.5	216	D
TN14	Hawthorn	1192.5	61	1.258	14CD	2.6	1.18	0.6	16	9.2	233	D
TN14	—	1250.0	91	1.289	14CD	2.6	1.18	0.6	16	9.2	233	D
TN14	Narcissus	1272.0	61	1.300	14CD	2.6	1.18	0.6	16	9.2	233	D
TN14	—	1300.0	91	1.315	14CD	2.6	1.18	0.6	16	9.2	233	D
TN15	Columbine	1351.5	61	1.340	15CD	3.1	1.41	0.7	17	9.8	248	D
TN15	Carnation	1431.0	61	1.379	15CD	3.1	1.41	0.7	17	9.8	248	D
TN15	—	1500.0	91	1.412	15CD	3.1	1.41	0.7	17	9.8	248	D
TN15	Gladiolus	1510.5	61	1.417	15CD	3.1	1.41	0.7	17	9.8	248	D
TN16	Coreopsis	1590.0	61	1.454	16CD	3.7	1.68	0.7	17	10.2	259	D
TN17	Jessamine	1750.0	61	1.525	17CD	4.6	2.09	0.7	17	11.2	264	E
TN18	Cowslip	2000.0	91	1.630	18CD	5.3	2.40	0.7	19	11.4	289	E
TN19	Sagebrush	2250.0	91	1.729	19CD	6.1	2.77	0.9	22	11.9	303	E
TN19	—	2300.0	91	1.750	19CD	6.1	2.77	0.9	22	11.9	303	E
TN20	Lupine	2500.0	91	1.823	20CD	6.9	3.13	0.9	22	12.6	321	E

Quick Compress Tee Connector for AAC Conductor, Open Run, TTOC Series

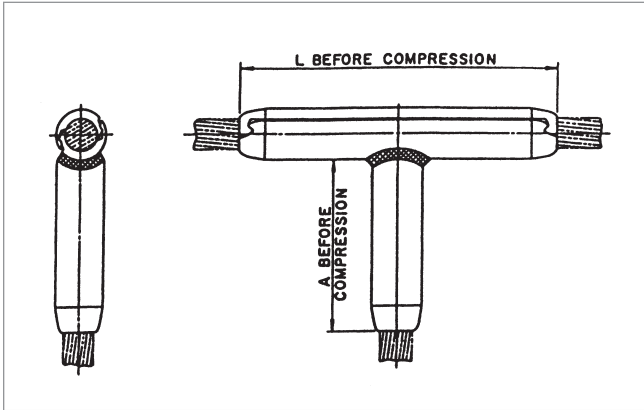

Ordering Instructions

Step 1: Assembly Catalog Number

Determine the assembly catalog number based on the conductor being used.

Example:

A tee connector for 795 Arbutus, the complete catalog number is:

TTOC11

The TTOC Series Open Run Tee Connector is a permanent drop specifically designed for ACSR, AAC, AAAC and ACAR conductors.

The end tapers of all compression accessories are supplied with a high voltage finish for die size sections 12CD and above.

Notes:

1. Tee Connectors are not prefilled with AFC.
2. Installation Instructions for Tee Connectors are on page 274.
3. For more information on die selection and ordering instructions, see Tools and Equipment tab in this catalog.

CATALOG NUMBER	CODE WORD	CONDUCTOR			DIE SIZE	TOTAL WEIGHT		DIMENSIONS			
		SIZE	STRANDING	DIAMETER		LBS	KG	A		L	
		KCMIL	AL	IN				IN	MM	IN	MM
TTOC07	Peony	300.0	19	0.629	07CD	0.5	0.22	3.9	100	6.4	163
TTOC07	Tulip	336.4	19	0.666	07CD	0.5	0.22	3.9	100	6.4	163
TTOC07	Daffodil	350.0	19	0.679	07CD	0.5	0.22	3.9	100	6.4	163
TTOC08	Canna	397.5	19	0.724	08CD	0.7	0.32	4.4	111	7.2	183
TTOC08	Goldentuft	450.0	19	0.770	08CD	0.7	0.32	4.4	111	7.2	183
TTOC09	Cosmos	477.0	19	0.793	09CD	1.0	0.45	4.8	122	7.9	199
TTOC09	Zinnia	500.0	19	0.811	09CD	1.0	0.45	4.8	122	7.9	199
TTOC10	Dahlia	556.5	19	0.856	10CD	1.3	0.59	5.3	133	8.5	216
TTOC10	Meadowsweet	600.0	37	0.891	10CD	1.3	0.59	5.3	133	8.5	216
TTOC10	Orchid	636.0	37	0.918	10CD	1.3	0.59	5.3	133	8.5	216
TTOC10	Heuchera	650.0	37	0.928	10CD	1.3	0.59	5.3	133	8.5	216
TTOC11	Verbena	700.0	37	0.963	11CD	1.7	0.77	5.7	145	9.2	234
TTOC11	Violet	715.5	37	0.974	11CD	1.7	0.77	5.7	145	9.2	234
TTOC11	Petunia	750.0	37	0.997	11CD	1.7	0.77	5.7	145	9.2	234
TTOC11	Arbutus	795.0	37	1.026	11CD	1.7	0.77	5.7	145	9.2	234
TTOC11	—	800.0	61	1.031	11CD	1.7	0.77	5.7	145	9.2	234
TTOP12	Cockscomb	900.0	37	1.092	12CD	2.1	0.95	6.1	155	9.9	250



Quick Compress Tee Connector for AAC Conductor, Open Run, TTOC Series (cont.)

CATALOG NUMBER	CONDUCTOR				DIE SIZE	TOTAL WEIGHT		DIMENSIONS			
	CODE WORD	SIZE	STRANDING	DIAMETER		LBS	KG	A		L	
		KCMIL	AL	IN				IN	MM	IN	MM
TTOC12	Magnolia	954.0	37	1.124	12CD	2.1	0.95	6.1	155	9.9	250
TTOC13	Hawkweed	1000.0	37	1.151	13CD	2.9	1.32	6.6	167	10.6	269
TTOC13	Bluebell	1033.5	37	1.170	13CD	2.9	1.32	6.6	167	10.6	269
TTOC13	Marigold	1113.0	61	1.216	13CD	2.9	1.32	6.6	167	10.6	269
TTOC14	Hawthorn	1192.5	61	1.258	14CD	3.5	1.59	7.0	178	11.2	285
TTOC14	—	1250.0	91	1.289	14CD	3.5	1.59	7.0	178	11.2	285
TTOC14	Narcissus	1272.0	61	1.300	14CD	3.5	1.59	7.0	178	11.2	285
TTOC14	—	1300.0	91	1.315	14CD	3.5	1.59	7.0	178	11.2	285
TTOC15	Columbine	1351.5	61	1.340	15CD	4.2	1.91	7.4	189	11.9	302
TTOC15	Carnation	1431.0	61	1.379	15CD	4.2	1.91	7.4	189	11.9	302
TTOC15	—	1500.0	91	1.412	15CD	4.2	1.91	7.4	189	11.9	302
TTOC15	Gladiolus	1510.5	61	1.417	15CD	4.2	1.91	7.4	189	11.9	302
TTOC16	Coreopsis	1590.0	61	1.454	16CD	5.0	2.27	7.8	198	12.5	316
TTOC17	Jessamine	1750.0	61	1.525	17CD	5.9	2.68	8.3	210	13.1	333
TTOC18	Cowslip	2000.0	91	1.630	18CD	7.0	3.16	8.6	219	13.7	348
TTOC19	Sagebrush	2250.0	91	1.729	19CD	8.0	3.63	9.1	230	14.4	364
TTOC19	—	2300.0	91	1.750	19CD	8.0	3.63	9.1	230	14.4	364
TTOC20	Lupine	2500.0	91	1.823	20CD	9.2	4.17	9.4	240	14.9	378

Quick Compress Tee Tap for AAC Conductor, Open Run, TTOP Series

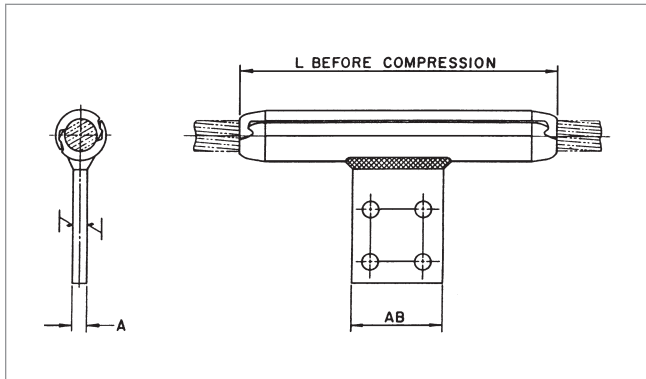

The TTOP Series Open Run Tee Tap is a permanent or temporary drop. By using a high strength alloy, the compression length has been shortened for less compression bites.

The run portion incorporates an improved design of interlocking extrusions, providing a permanent grip on the conductor when compressed.

The end tapers of all compression accessories are supplied with a High Voltage finish for die size sections 12CD and above.

The square edges of bolted pads of the compression accessories could cause Corona. Pads with edges and corners rounded can be supplied by adding the catalog suffix 'EHV'.

Ordering Instructions

Step 1: Assembly Catalog Number

Determine the assembly catalog number based on the conductor being used.

Step 2: Extra High Voltage Finish

For Extra High Voltage Finish, use 'EHV'. (≥ 345 kV)

For Standard Finish, leave blank. (< 345 kV)

Step 3: Assemble Catalog Number.

Assy Catalog Number	+	EHV Finish
------------------------	---	---------------

Example:

A tee tap for 795 Arbutus with EHV finish, the complete catalog number is:

TTOP11EHV

Notes:

1. Installation Instructions for Tee Taps are on page 274.
2. For more information on die selection and ordering instructions, see Tools and Equipment tab in this catalog.

Quick Compress Tee Tap for AAC Conductor, Open Run, TTOP Series (cont.)

CATALOG NUMBER	CONDUCTOR				DIE SIZE	WEIGHT		DIMENSIONS						PAD SIZE
	CODE WORD	SIZE	STRANDING	DIAMETER		ALUMINUM		A		L		AB		
		KCMIL	AL/ST	IN		LBS	KG	IN	MM	IN	MM	IN	MM	
TTOP07	Peony	300.6	19	0.629	07CD	0.6	0.27	0.4	10	7.4	187	2.0	51	B
TTOP07	Tulip	336.4	19	0.666	07CD	0.6	0.27	0.4	10	7.4	187	2.0	51	B
TTOP07	Daffodil	350.0	19	0.679	07CD	0.6	0.27	0.4	10	7.4	187	2.0	51	B
TTOP08	Canna	397.5	19	0.724	08CD	0.7	0.34	0.4	10	8.0	202	2.0	51	B
TTOP09	Goldentuft	450.0	19	0.770	09CD	0.9	0.41	0.4	10	8.5	215	2.0	51	B
TTOP09	Cosmos	477.0	19	0.793	09CD	0.9	0.41	0.4	10	8.5	215	2.0	51	B
TTOP09	Zinnia	500.0	19	0.811	09CD	0.9	0.41	0.4	10	8.5	215	2.0	51	B
TTOP10	Dahlia	556.5	19	0.856	10CD	1.0	0.45	0.4	10	9.0	229	2.0	51	B
TTOP10	Meadowsweet	600.0	37	0.891	10CD	1.0	0.45	0.4	10	9.0	229	2.0	51	B
TTOP10	Orchid	636.0	37	0.918	10CD	1.0	0.45	0.4	10	9.0	229	2.0	51	B
TTOP10	Heuchera	650.0	37	0.928	10CD	1.0	0.45	0.4	10	9.0	229	2.0	51	B
TTOP11	Verbena	700.0	37	0.963	11CD	1.7	0.77	0.5	13	10.5	267	3.0	76	D
TTOP11	Violet	715.5	37	0.974	11CD	1.7	0.77	0.5	13	10.5	267	3.0	76	D
TTOP11	Petunia	750.0	37	0.997	11CD	1.7	0.77	0.5	13	10.5	267	3.0	76	D
TTOP11	Arbutus	795.0	37	1.026	11CD	1.7	0.77	0.5	13	10.5	267	3.0	76	D
TTOP11	—	800.0	61	1.031	11CD	1.7	0.77	0.5	13	10.5	267	3.0	76	D
TTOP12	Cockscomb	900.0	37	1.092	12CD	2.0	0.91	0.5	13	11.1	281	3.0	76	D
TTOP12	Magnolia	954.0	37	1.124	12CD	2.0	0.91	0.5	13	11.1	281	3.0	76	D
TTOP13	Hawkweed	1000.0	37	1.151	13CD	2.4	1.09	0.5	13	11.6	294	3.0	76	D
TTOP13	Bluebell	1033.5	37	1.170	13CD	2.4	1.09	0.5	13	11.6	294	3.0	76	D
TTOP13	Marigold	1113.0	61	1.216	13CD	2.4	1.09	0.5	13	11.6	294	3.0	76	D
TTOP14	Hawthorn	1192.5	61	1.258	14CD	2.8	1.27	0.5	13	12.1	307	3.0	76	D
TTOP14	—	1250.0	91	1.289	14CD	2.8	1.27	0.5	13	12.1	307	3.0	76	D
TTOP14	Narcissus	1272.0	61	1.300	14CD	2.8	1.27	0.5	13	12.1	307	3.0	76	D
TTOP14	—	1300.0	91	1.315	14CD	2.8	1.27	0.5	13	12.1	307	3.0	76	D
TTOP15	Columbine	1351.5	61	1.340	15CD	3.3	1.50	0.5	13	12.6	321	3.0	76	D
TTOP15	Carnation	1431.0	61	1.379	15CD	3.3	1.50	0.5	13	12.6	321	3.0	76	D
TTOP15	—	1500.0	91	1.412	15CD	3.3	1.50	0.5	13	12.6	321	3.0	76	D
TTOP15	Gladiolus	1510.5	61	1.417	15CD	3.3	1.50	0.5	13	12.6	321	3.0	76	D
TTOP16	Coreopsis	1590.0	61	1.454	16CD	3.7	1.68	0.5	13	13.2	334	3.0	76	D
TTOP17	Jessamine	1750.0	61	1.525	17CD	5.2	2.36	0.8	19	14.6	370	4.0	102	E
TTOP18	Cowslip	2000.0	91	1.630	18CD	5.9	2.68	0.8	19	15.0	380	4.0	102	E
TTOP19	Sagebrush	2250.0	91	1.729	19CD	6.5	2.95	0.8	19	15.5	393	4.0	102	E
TTOP19	—	2300.0	91	1.750	19CD	6.5	2.95	0.8	19	15.5	393	4.0	102	E
TTOP20	Lupine	2500.0	91	1.823	20CD	7.2	3.27	0.8	19	15.9	403	4.0	102	E

Quick Compress Dead Ends for AAC and ACAR Conductor, Eye Type, Single Tongue, VES/HES Series

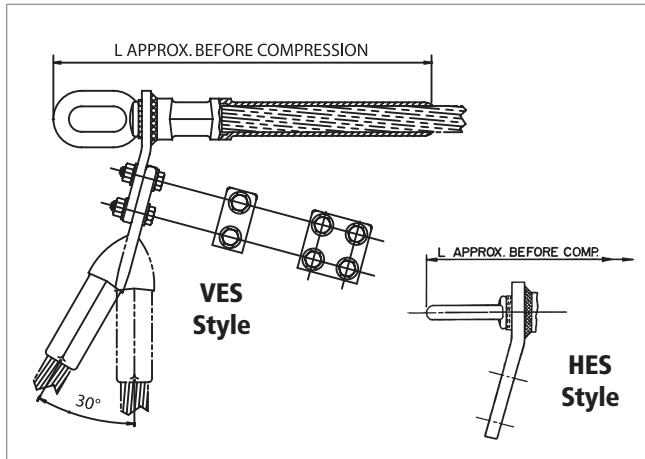

The Quick Compress Dead Ends are designed for fast and easy installation. By using a high strength alloy, the compression length has been shortened for less compression bites while maintaining a minimum 95% of the ASTM rated strength. The steel eye is pre-compressed and the dead end pre-filled, eliminating installation steps.

The dead end tongue and terminal pad are each constructed with a 15° angle, which permits the terminal connector to be bolted in either the straight or the 30° position. Both sides of the pad are finished, creating excellent electrical contact surfaces. For pad to pad connections, AFL recommends the use of No. 2 EJC.

The end tapers of all compression accessories are supplied with a high voltage finish for die sizes 12CD and above. Corona bolts are furnished standard on 15° terminals for these section sizes. The square edges of bolted pads of the compression accessories could cause Corona. Pads with rounded edges and corners can be supplied by adding the catalog suffix 'EHV'.

Ordering Instructions

Step 1: Assembly Catalog Number

Determine the assembly catalog number based on the conductor being used.

Step 2: Terminal Connector

For an assembly without a terminal connector, use 'NT'.
For an assembly with a terminal connector, leave blank.

Step 3: Extra High Voltage Finish

For Extra High Voltage Finish, use 'EHV'. (≥ 345 kV)
For Standard Finish, leave blank. (< 345 kV).

Step 4: Assemble Catalog Number.



Example:

For a vertical eye dead end with no terminal and EHV finish for 927.2 Greeley, the complete catalog number is:

VES120NTEHV

Notes:

1. Assembly Catalog Number includes dead end, terminal connector and aluminum hardware.
2. Eye Dimensions are on page 257.
3. Pad Dimensions are on page 257.
4. Installation Instructions for Dead Ends are on page 266.
5. Installation Instructions for Terminals are on page 272.
6. For more information on die selection and ordering instructions, see Tools and Equipment tab in this catalog.



Quick Compress Dead Ends for AAAC and ACAR Conductor, Eye Type, Single Tongue, VES/HES Series (cont.)

ASSEMBLY CATALOG NUMBER		CONDUCTOR			DIE SIZE	TOTAL		DIMENSION L		PAD SIZE
VERTICAL EYE	HORIZONTAL EYE	CODE WORD	SIZE KCMIL	DIAMETER IN		LBS	KG	IN	MM	
VES070	HES070	—	281.4	0.609	07CD	1.8	0.82	11.5	292	B
VES070	HES070	Butte	312.8	0.642	07CD	1.8	0.82	11.5	292	B
VES080	HES080	—	355.1	0.684	08CD	2.3	1.04	12.3	313	B
VES080	HES080	Canton	394.5	0.721	08CD	2.3	1.04	12.3	313	B
VES080	HES080	—	419.6	0.743	08CD	2.3	1.04	12.3	313	B
VES090	HES090	Cairo	465.4	0.783	09CD	3.1	1.41	13.8	351	B
VES090	HES090	—	503.6	0.814	09CD	3.1	1.41	13.8	351	B
VES100	VES100	Darien	559.5	0.858	10CD	3.6	1.63	14.7	373	B
VES100	VES100	—	587.2	0.879	10CD	3.6	1.63	14.7	373	B
VES100	VES100	—	634.9	0.914	10CD	3.6	1.63	14.7	373	B
VES100	VES100	—	649.5	0.928	10CD	3.6	1.63	14.7	373	B
VES100	VES100	Elgin	652.4	0.927	10CD	3.6	1.63	14.7	373	B
VES100	VES100	—	657.3	0.930	10CD	3.6	1.63	14.7	373	B
VES110	HES110	Flint	740.8	0.991	11CD	5.5	2.49	15.9	403	D
VES120	HES120	—	853.7	1.063	12CD	6.3	2.86	16.7	424	D
VES120	HES120	Greeley	927.2	1.108	12CD	6.3	2.86	16.7	424	D
VES130	HES130	—	1024.5	1.165	13CD	8.4	3.81	19.0	483	D
VES130	HES130	—	1080.6	1.196	13CD	8.4	3.81	19.0	483	D
VES130	HES130	—	1108.6	1.212	13CD	8.4	3.81	19.0	483	D
VES140	HES140	—	1172.3	1.246	14CD	9.6	4.35	19.8	503	D
VES160	HES160	—	1534.0	1.427	16CD	13.4	6.08	22.3	567	D
VES160	HES160	—	1700.0	1.502	16CD	13.4	6.08	22.3	567	D
VES190	HES190	—	2303.5	1.750	19CD	22.8	10.34	26.2	665	E
VES190	HES190	—	2338.0	1.762	19CD	22.8	10.34	26.2	665	E
VES200	HES200	—	2493.0	1.821	20CD	24.2	10.98	27.0	686	E

QuickCompress®—AAAC & ACAR

Quick Compress Dead Ends for AAC and ACAR Conductor, Eye Type, Double Tongue, VED/HED Series

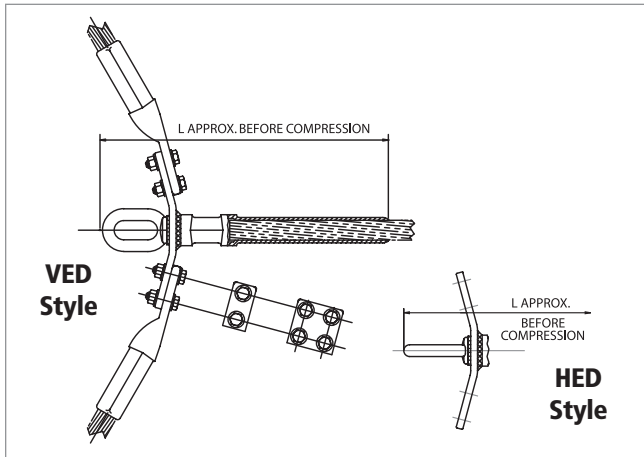

The Quick Compress Dead Ends are designed for fast and easy installation. By using a high strength alloy, the compression length has been shortened for less compression bites while maintaining a minimum 95% of the ASTM rated strength. The steel eye is pre-compressed and the dead end pre-filled, eliminating installation steps.

The dead end tongue and terminal pad are each constructed with a 15° angle, which permits the terminal connector to be bolted in either the straight or the 30° position. Both sides of the pad are finished, creating excellent electrical contact surfaces. For pad to pad connections, AFL recommends the use of No. 2 EJC.

The end tapers of all compression accessories are supplied with a high voltage finish for die sizes 12CD and above. Corona bolts are furnished standard on 15° terminals for these section sizes. The square edges of bolted pads of the compression accessories could cause Corona. Pads with rounded edges and corners can be supplied by adding the catalog suffix 'EHV'.

Ordering Instructions

Step 1: Assembly Catalog Number

Determine the assembly catalog number based on the conductor being used.

Step 2: Terminal Connector

For an assembly without a terminal connector, use 'NT'.
For an assembly with a terminal connector, leave blank.

Step 3: Extra High Voltage Finish

For Extra High Voltage Finish, use 'EHV'. (≥ 345 kV)
For Standard Finish, leave blank. (< 345 kV)

Step 4: Assemble Catalog Number.

Assy Catalog Number	+	Terminal Connector	+	EHV Finish
------------------------	---	-----------------------	---	---------------

Example:

For a vertical eye dead end with no terminal and EHV finish for 927.2 Greeley, the complete catalog number is:

VED120NTEHV

Notes:

1. Assembly Catalog Number includes dead end, two terminal connectors and aluminum hardware.
2. Eye Dimensions are on page 257.
3. Pad Dimensions are on page 257.
4. Installation Instructions for Dead Ends are on page 266.
5. Installation Instructions for Terminals are on page 272.
6. For more information on die selection and ordering instructions, see Tools and Equipment tab in this catalog.



Quick Compress Dead Ends for AAAC and ACAR Conductor, Eye Type, Double Tongue, VED/HED Series (cont.)

ASSEMBLY CATALOG NUMBER		CONDUCTOR			DIE SIZE	TOTAL WEIGHT		DIMENSION L		PAD SIZE
VERTICAL EYE	HORIZONTAL EYE	CODE NAME	SIZE	DIAMETER		LBS	KG	IN	MM	
			KCMIL	IN						
VED070	HED070	—	281.4	0.609	07CD	2.8	1.27	11.5	292	B
VED070	HED070	Butte	312.8	0.642	07CD	2.8	1.27	11.5	292	B
VED080	HED080	—	355.1	0.684	08CD	3.3	1.5	12.3	313	B
VED080	HED080	Canton	394.5	0.721	08CD	3.3	1.5	12.3	313	B
VED080	HED080	—	419.6	0.743	08CD	3.3	1.5	12.3	313	B
VED090	HED090	Cairo	465.4	0.783	09CD	4.3	1.95	13.8	351	B
VED090	HED090	—	503.6	0.814	09CD	4.3	1.95	13.8	351	B
VED100	VED100	Darien	559.5	0.858	10CD	5.2	2.36	14.7	373	B
VED100	VED100	—	587.2	0.879	10CD	5.2	2.36	14.7	373	B
VED100	VED100	—	634.9	0.914	10CD	5.2	2.36	14.7	373	B
VED100	VED100	—	649.5	0.928	10CD	5.2	2.36	14.7	373	B
VED100	VED100	Elgin	652.4	0.927	10CD	5.2	2.36	14.7	373	B
VED100	VED100	—	657.3	0.930	10CD	5.2	2.36	14.7	373	B
VED110	HED110	Flint	740.8	0.991	11CD	7.7	3.49	15.9	403	D
VED120	HED120	—	853.7	1.063	12CD	9.0	4.06	16.7	424	D
VED120	HED120	Greeley	927.2	1.108	12CD	9.0	4.06	16.7	424	D
VED130	HED130	—	1024.5	1.165	13CD	11.5	5.22	19.0	483	D
VED130	HED130	—	1080.6	1.196	13CD	11.5	5.22	19.0	483	D
VED130	HED130	—	1108.6	1.212	13CD	11.5	5.22	19.0	483	D
VED140	HED140	—	1172.3	1.246	14CD	13.2	5.99	19.8	503	D
VED160	HED160	—	1534	1.427	16CD	18.0	8.16	22.3	567	D
VED160	HED160	—	1700	1.502	16CD	18.0	8.16	22.3	567	D
VED190	HED190	—	2303.5	1.750	19CD	30.2	13.70	26.2	665	E
VED190	HED190	—	2338	1.762	19CD	30.2	13.70	26.2	665	E
VED200	HED200	—	2493	1.821	20CD	32.0	14.51	27.0	686	E

Quick Compress Dead Ends for AAAC and ACAR Conductor, Adjustable Clevis Type, Single Tongue, ACS Series

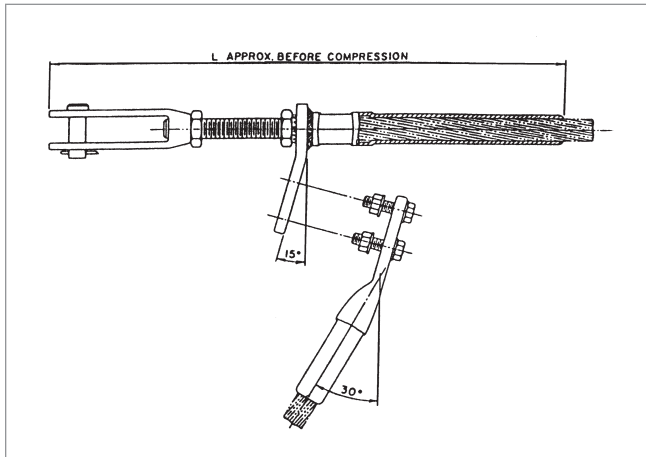

The Quick Compress Dead Ends are designed for fast and easy installation. By using a high strength alloy, the compression length has been shortened for less compression bites while maintaining a minimum 95% of the ASTM rated strength. The adjustable steel clevis is pre-compressed and the dead end pre-filled, eliminating installation steps.

The dead end tongue and terminal pad are each constructed with a 15° angle, which permits the terminal connector to be bolted in either the straight or the 30° position. Both sides of the pad are finished, creating excellent electrical contact surfaces. For pad to pad connections, AFL recommends the use of No. 2 EJC.

The end tapers of all compression accessories are supplied with a high voltage finish for die sizes 12CD and above. Corona bolts are furnished standard on 15° terminals for these section sizes. The square edges of bolted pads of the compression accessories could cause Corona. Pads with rounded edges and corners can be supplied by adding the catalog suffix 'EHV'.

Ordering Instructions

Step 1: Assembly Catalog Number

Determine the assembly catalog number based on the conductor being used.

Step 2: Terminal Connector

For an assembly without a terminal connector, use 'NT'.
For an assembly with a terminal connector, leave blank.

Step 3: Extra High Voltage Finish

For Extra High Voltage Finish, use 'EHV'. (≥ 345 kV)
For Standard Finish, leave blank. (< 345 kV)

Step 4: Assemble Catalog Number.

Assy Catalog Number	+	Terminal Connector	+	EHV Finish
------------------------	---	-----------------------	---	---------------

Example:

For an adjustable clevis dead end with no terminal and EHV finish for 927.2 Greeley, the complete catalog number is:

ACS120NTEHV

Notes:

1. Assembly Catalog Number includes dead end, terminal connector and aluminum hardware.
2. Clevis Dimensions are on page 258.
3. Pad Dimensions are on page 257.
4. Installation Instructions for Dead Ends are on page 266.
5. Installation Instructions for Terminals are on page 272.
6. For more information on die selection and ordering instructions, see Tools and Equipment tab in this catalog.



Quick Compress Dead Ends for AAAC and ACAR Conductor, Adjustable Clevis Type, Single Tongue, ACS Series (cont.)

ASSEMBLY CATALOG NUMBER	CONDUCTOR			DIE SIZE	TOTAL WEIGHT		DIMENSION L		PAD SIZE
	CODE WORD	SIZE	DIAMETER		LBS	KG	IN	MM	
		KCMIL	IN						
ACS070	—	281.4	0.609	07CD	4.3	1.95	19.3	489	B
ACS070	Butte	312.8	0.642	07CD	4.3	1.95	19.3	489	B
ACS080	—	355.1	0.684	08CD	5.0	2.31	20.2	513	B
ACS080	Canton	394.5	0.721	08CD	5.0	2.31	20.2	513	B
ACS080	—	419.6	0.743	08CD	5.0	2.31	20.2	513	B
ACS090	Cairo	465.4	0.783	09CD	6.2	2.81	21.7	551	B
ACS090	—	503.6	0.814	09CD	6.2	2.81	21.7	551	B
ACS100	Darien	559.5	0.858	10CD	6.7	3.04	22.5	572	B
ACS100	—	587.2	0.879	10CD	6.7	3.04	22.5	572	B
ACS100	—	634.9	0.914	10CD	6.7	3.04	22.5	572	B
ACS100	—	649.5	0.928	10CD	6.7	3.04	22.5	572	B
ACS100	Elgin	652.4	0.927	10CD	6.7	3.04	22.5	572	B
ACS100	—	657.3	0.930	10CD	6.7	3.04	22.5	572	B
ACS110	Flint	740.8	0.991	11CD	11.1	5.03	25.9	659	D
ACS120	—	853.7	1.063	12CD	11.9	5.40	26.8	679	D
ACS120	Greeley	927.2	1.108	12CD	11.9	5.40	26.8	679	D
ACS130	—	1024.5	1.165	13CD	15.0	6.80	28.7	729	D
ACS130	—	1080.6	1.196	13CD	15.0	6.80	28.7	729	D
ACS130	—	1108.6	1.212	13CD	15.0	6.80	28.7	729	D
ACS140	—	1172.3	1.246	14CD	16.1	7.30	29.5	749	D
ACS160	—	1534.0	1.427	16CD	23.5	10.66	34.4	873	D
ACS160	—	1700.0	1.502	16CD	23.5	10.66	34.4	873	D
ACS190	—	2303.5	1.750	19CD	36.6	16.60	38.2	970	E
ACS190	—	2338.0	1.762	19CD	36.6	16.60	38.2	970	E
ACS200	—	2493.0	1.821	20CD	37.9	17.19	39.0	991	E

Quick Compress Dead Ends for AAAC and ACAR Conductor, Adjustable Eye Type, Single Tongue, AES Series

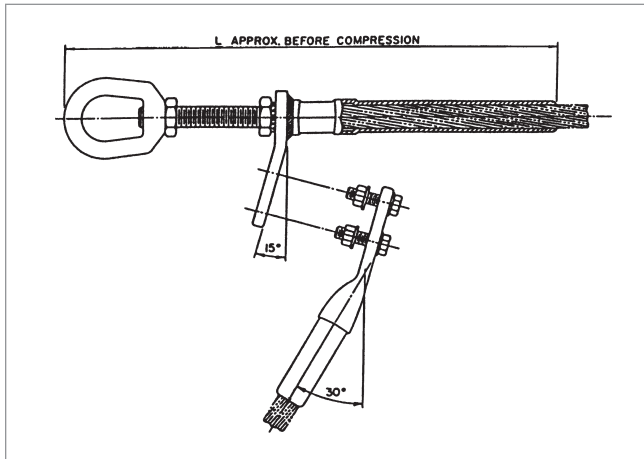

The Quick Compress Dead Ends are designed for fast and easy installation. By using a high strength alloy, the compression length has been shortened for less compression bites while maintaining a minimum 95% of the ASTM rated strength. The adjustable steel eye is pre-compressed and the dead end pre-filled, eliminating installation steps.

The dead end tongue and terminal pad are each constructed with a 15° angle, which permits the terminal connector to be bolted in either the straight or the 30° position. Both sides of the pad are finished, creating excellent electrical contact surfaces. For pad to pad connections, AFL recommends the use of No. 2 EJC.

The end tapers of the compression portions of all compression accessories are supplied with a High Voltage finish for die size sections 12CD and above. Corona bolts are furnished standard on 15° terminals for these section sizes.

The square edges of bolted pads of the compression accessories could cause Corona. Pads with edges and corners rounded can be supplied by adding the catalog suffix 'EHV'.

Ordering Instructions

Step 1: Assembly Catalog Number

Determine the assembly catalog number based on the conductor being used.

Step 2: Terminal Connector

For an assembly without a terminal connector, use 'NT'.
For an assembly with a terminal connector, leave blank.

Step 3: Extra High Voltage Finish

For Extra High Voltage Finish, use 'EHV'. (≥ 345 kV)
For Standard Finish, leave blank. (< 345 kV)

Step 4: Assemble Catalog Number.

Assy Catalog Number	+	Terminal Connector	+	EHV Finish
------------------------	---	-----------------------	---	---------------

Example:

For an adjustable eye dead end with no terminal and EHV finish for 927.7 Greeley, the complete catalog number is:

AES120NTEHV

Notes:

1. Assembly Catalog Number includes dead end, terminal connector and aluminum hardware.
2. Eye Dimensions are on page 258.
3. Pad Dimensions are on page 257.
4. Installation Instructions for Dead Ends are on page 266.
5. Installation Instructions for Terminals are on page 272.
6. For more information on die selection and ordering instructions, see Tools and Equipment tab in this catalog.

Quick Compress Dead Ends for AAAC and ACAR Conductor, Adjustable Eye Type, Single Tongue, AES Series (cont.)

ASSEMBLY CATALOG NUMBER	CONDUCTOR			DIE SIZE	TOTAL WEIGHT		DIMENSION L		PAD SIZE
	CODE WORD	SIZE	DIAMETER		LBS	KG	IN	MM	
		KCMIL	IN						
AES070	—	281.4	0.609	07CD	2.6	1.18	16.4	418	B
AES070	Butte	312.8	0.642	07CD	2.6	1.18	16.4	418	B
AES080	—	355.1	0.684	08CD	3.8	1.72	17.8	453	B
AES080	Canton	394.5	0.721	08CD	3.8	1.72	17.8	453	B
AES080	—	419.6	0.743	08CD	3.8	1.72	17.8	453	B
AES090	Cairo	465.4	0.783	09CD	5.6	2.54	19.7	501	B
AES090	—	503.6	0.814	09CD	5.6	2.54	19.7	501	B
AES100	Darien	559.5	0.858	10CD	6.1	2.77	20.5	521	B
AES100	—	587.2	0.879	10CD	6.1	2.77	20.5	521	B
AES100	—	634.9	0.914	10CD	6.1	2.77	20.5	521	B
AES100	—	649.5	0.928	10CD	6.1	2.77	20.5	521	B
AES100	Elgin	652.4	0.927	10CD	6.1	2.77	20.5	521	B
AES100	—	657.3	0.930	10CD	6.1	2.77	20.5	521	B
AES110	Flint	740.8	0.991	11CD	9.1	4.13	23.3	591	D
AES120	—	853.7	1.063	12CD	9.9	4.49	24.1	611	D
AES120	Greeley	927.2	1.108	12CD	9.9	4.49	24.1	611	D
AES130	—	1024.5	1.165	13CD	13.9	6.3	26.5	673	D
AES130	—	1080.6	1.196	13CD	13.9	6.3	26.5	673	D
AES130	—	1108.6	1.212	13CD	13.9	6.3	26.5	673	D
AES140	—	1172.3	1.246	14CD	15.0	6.8	27.3	694	D
AES160	—	1534.0	1.427	16CD	23.2	10.52	31.7	806	D
AES160	—	1700.0	1.502	16CD	23.2	10.52	31.7	806	D
AES190	—	2303.5	1.750	19CD	33.4	15.15	35.2	895	E
AES190	—	2338.0	1.762	19CD	33.4	15.15	35.2	895	E
AES200	—	2493.0	1.821	20CD	35.0	15.88	36.0	915	E

Quick Compress Compression Joints for AACR Conductor, CJ Series

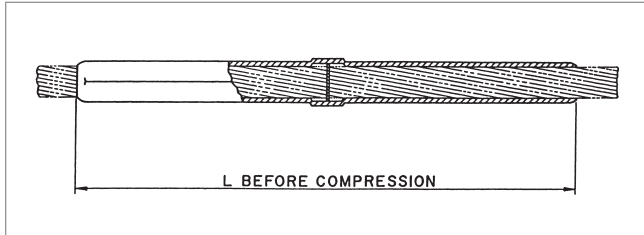

The Quick Compress CJ Series Joints are designed for fast and easy installation. By using a high strength alloy, the compression length has been shortened for less compression bites while maintaining a minimum 95% of the ASTM rated strength. The compression joint is pre-filled, eliminating an installation step. Each compression joint has a center stop to ensure proper insertion of the conductor.

The end tapers of all compression accessories are supplied with a high voltage finish for die size sections 12CD and above.

Ordering Instructions

Step 1: Assembly Catalog Number

Determine the assembly catalog number based on the conductor being used.

Example:

A compression joint for 312.8 Butte conductor, the complete catalog number is:

CJ07

Notes:

1. Installation Instructions for Compression Joints are on page 268.
2. For more information on die selection and ordering instructions, see Tools and Equipment tab in this catalog.

CATALOG NUMBER	CONDUCTOR				DIE SIZE	TOTAL WEIGHT		DIMENSION L	
	CODE NAME	SIZE	DIAMETER			LBS	KG	IN	MM
		KCMIL	IN	MM					
CJ07	—	281.4	0.609	15.47	07CD	0.58	0.26	11.2	284
CJ07	Butte	312.8	0.642	16.31	07CD	0.58	0.26	11.2	284
CJ08	—	355.1	0.684	17.37	08CD	0.86	0.39	12.8	325
CJ08	Canton	394.6	0.721	18.33	08CD	0.86	0.39	12.8	325
CJ08	—	419.6	0.743	18.87	08CD	0.86	0.39	12.8	325
CJ09	Cairo	465.4	0.783	19.89	09CD	1.20	0.54	14.4	368
CJ09	—	503.6	0.814	20.67	09CD	1.20	0.54	14.4	368
CJ10	Darien	559.5	0.858	21.79	10CD	1.70	0.77	16.0	406
CJ10	—	587.2	0.879	22.33	10CD	1.70	0.77	16.0	406
CJ10	—	634.9	0.914	23.22	10CD	1.70	0.77	16.0	406
CJ10	—	649.5	0.928	23.57	10CD	1.70	0.77	16.0	406
CJ10	Elgin	652.4	0.927	23.55	10CD	1.70	0.77	16.0	406
CJ10	—	657.3	0.930	23.62	10CD	1.70	0.77	16.0	406
CJ11	Flint	740.8	0.991	25.17	11CD	2.30	1.04	17.6	447
CJ12	—	853.7	1.063	27.00	12CD	3.00	1.36	19.2	488
CJ12	Greeley	927.2	1.108	28.14	12CD	3.00	1.36	19.2	488
CJ13	—	1024.5	1.165	29.59	13CD	3.80	1.72	20.8	528
CJ13	—	1080.6	1.196	30.38	13CD	3.80	1.72	20.8	528



Quick Compress Compression Joints for AAAC Conductor, CJ Series (cont.)

CATALOG NUMBER	CONDUCTOR				DIE SIZE	TOTAL WEIGHT		DIMENSION L	
	CODE NAME	SIZE	DIAMETER			LBS	KG	IN	MM
		KCMIL	IN	MM					
CJ13	—	1108.6	1.212	30.81	13CD	3.80	1.72	20.8	528
CJ14	—	1172.3	1.246	31.65	14CD	4.60	2.09	22.4	569
CJ16	—	1534.0	1.427	36.25	16CD	6.90	3.13	25.6	650
CJ16	—	1700.0	1.502	38.15	16CD	6.90	3.13	25.6	650
CJ19	—	2303.5	1.750	44.45	19CD	11.60	5.26	30.4	772
CJ19	—	2338.0	1.762	44.75	19CD	11.60	5.26	30.4	772
CJ20	—	2493.0	1.821	46.25	20CD	13.10	5.94	32.0	813

Quick Compress Replacement Compression Joints for AAC and ACAR Conductor, CJR Series

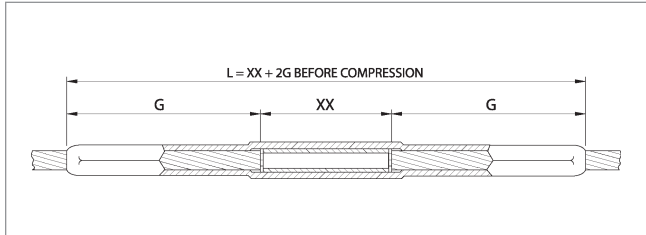

The Quick Compress Replacement Joints are used to replace damaged conductor in midspan. They are designed for fast and easy installation. By using a high strength alloy, the compression length has been shortened for less compression bits, while maintaining a minimum 95% of the ASTM rated strength. The replacement joint is pre-filled, eliminating an installation step.

The end tapers of all compression accessories are supplied with a high voltage finish for die size sections 12CD and above.

Ordering Instructions

Step 1: Assembly Catalog Number

Determine the assembly catalog number based on the conductor being used.

Step 2: Determine Length of Conductor Removed (XX)

Determine the length of conductor (XX) that will be cut out, to the nearest inch (Maximum 48").

Step 3: Assemble Catalog Number

Catalog Number + **Removed Conductor Length (XX)**

Example:

A replacement compression joint for 312.8 Butte conductor with a removed conductor length of 24 inches, the complete catalog number is:

CJ070R24

Notes:

1. Installation Instructions for Compression Joints are on page 268.
2. For more information on die selection and ordering instructions, see Tools and Equipment tab in this catalog.

CATALOG NUMBER	CONDUCTOR			DIE SIZE	DIMENSION L	
	CODE WORD	SIZE	DIAMETER		IN	MM
		KCMIL	IN			
CJ070RXX	—	281.4	0.609	07CD	7.6	192
CJ070RXX	Butte	312.8	0.642	07CD	7.6	192
CJ080RXX	—	355.1	0.684	08CD	8.4	212
CJ080RXX	Canton	394.5	0.721	08CD	8.4	212
CJ080RXX	—	419.6	0.743	08CD	8.4	212
CJ090RXX	Cairo	465.4	0.783	09CD	9.2	233
CJ090RXX	—	503.6	0.814	09CD	9.2	233
CJ100RXX	Darien	559.5	0.858	10CD	10.0	253
CJ100RXX	—	587.2	0.879	10CD	10.0	253
CJ100RXX	—	634.9	0.914	10CD	10.0	253
CJ100RXX	—	649.5	0.928	10CD	10.0	253
CJ100RXX	Elgin	652.4	0.927	10CD	10.0	253
CJ100RXX	—	657.3	0.930	10CD	10.0	253
CJ110RXX	Flint	740.8	0.991	11CD	10.8	273
CJ120RXX	—	853.7	1.063	12CD	11.6	294
CJ120RXX	Greeley	927.2	1.108	12CD	11.6	294
CJ130RXX	—	1024.5	1.165	13CD	12.4	314
CJ130RXX	—	1080.6	1.196	13CD	12.4	314



Quick Compress Replacement Compression Joints for AAAC and ACAR Conductor, CJR Series (cont.)

CATALOG NUMBER	CONDUCTOR			DIE SIZE	DIMENSION L	
	CODE WORD	SIZE	DIAMETER		IN	MM
		KCMIL	IN			
CJ130RXX	—	1108.6	1.212	13CD	12.4	314
CJ140RXX	—	1172.3	1.246	14CD	13.2	334
CJ160RXX	—	1534.0	1.427	16CD	14.8	375
CJ160RXX	—	1700.0	1.502	16CD	14.8	375
CJ190RXX	—	2303.5	1.750	19CD	17.2	436
CJ190RXX	—	2338.0	1.762	19CD	17.2	436
CJ200RXX	—	2493.0	1.821	20CD	18.0	456

Quick Compress Repair Sleeve for AAAC and ACAR Conductor, RS Series

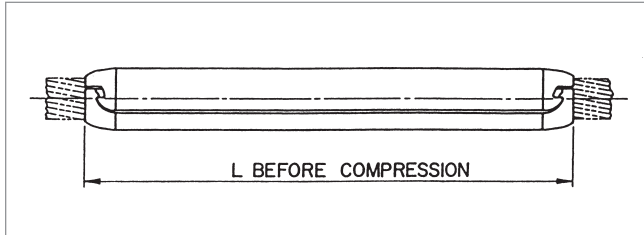

The Quick Compress Repair Sleeve is designed for ACSR, AAC, AAAC and ACAR conductors. The repair sleeve incorporates an improved design of interlocking extrusions, providing a permanent grip on the conductor when compressed.

The repair sleeve will restore the conductor to 95% of its ASTM rated strength where up to one-third of the aluminum strands are damaged.

Ordering Instructions

Step 1: Assembly Catalog Number

Determine the assembly catalog number based on the conductor being used.

Example:

A repair sleeve for 927.7 Greeley conductor, the complete catalog number is:

RS11

Notes:

1. Installation Instructions for Compression Joints are on page 270.
2. For more information on die selection and ordering instructions, see the AFL Tool Catalog.

CATALOG NUMBER	CONDUCTOR			DIE SIZE	TOTAL WEIGHT		DIMENSION L	
	CODE WORD	SIZE	DIAMETER		LBS	KG	IN	MM
		KCMIL	IN					
RS07	—	281.4	0.609	07CD	0.4	0.17	8.4	213
RS07	Butte	312.8	0.642	07CD	0.4	0.17	8.4	213
RS08	—	355.1	0.684	08CD	0.6	0.26	9.6	244
RS08	Canton	394.5	0.721	08CD	0.6	0.26	9.6	244
RS08	—	419.6	0.743	08CD	0.6	0.26	9.6	244
RS09	Cairo	465.4	0.783	09CD	0.8	0.38	10.8	274
RS09	—	503.6	0.814	09CD	0.8	0.38	10.8	274
RS10	Darien	559.5	0.858	10CD	1.1	0.50	12.0	305
RS10	—	587.2	0.879	10CD	1.1	0.50	12.0	305
RS10	—	634.9	0.914	10CD	1.1	0.50	12.0	305
RS10	—	649.5	0.928	10CD	1.1	0.50	12.0	305
RS10	Elgin	652.4	0.927	10CD	1.1	0.50	12.0	305
RS10	—	657.3	0.930	10CD	1.1	0.50	12.0	305
RS11	Flint	740.8	0.991	11CD	1.5	0.68	13.2	335
RS12	—	853.7	1.063	12CD	1.9	0.86	14.4	366
RS12	Greeley	927.2	1.108	12CD	1.9	0.86	14.4	366
RS13	—	1024.5	1.165	13CD	2.4	1.09	15.6	396



Quick Compress Repair Sleeve for AAAC and ACAR Conductor, RS Series (cont.)

CATALOG NUMBER	CONDUCTOR			DIE SIZE	TOTAL WEIGHT		DIMENSION L	
	CODE WORD	SIZE	DIAMETER		LBS	KG	IN	MM
		KCMIL	IN					
RS13	—	1080.6	1.196	13CD	2.4	1.09	15.6	396
RS13	—	1108.6	1.212	13CD	2.4	1.09	15.6	396
RS14	—	1172.3	1.246	14CD	3.1	1.41	16.8	427
RS16	—	1534.0	1.427	16CD	4.6	2.09	19.2	488
RS16	—	1700.0	1.502	16CD	4.6	2.09	19.2	488
RS19	—	2303.5	1.750	19CD	7.8	3.54	22.8	579
RS19	—	2338.0	1.762	19CD	7.8	3.54	22.8	579
RS20	—	2493.0	1.821	20CD	9.1	4.13	24.0	610

Quick Compress Jumper Connector for AAAC and ACAR Conductor, JC Series

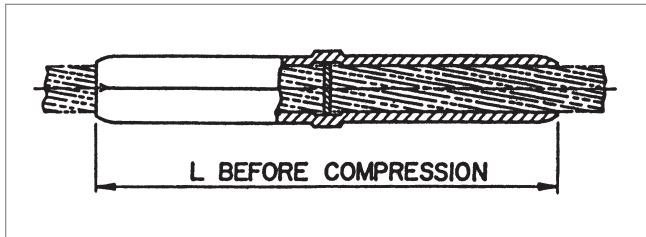

The Quick Compress Jumper Connector is designed for fast and easy installation. By using a high strength alloy, the compression length has been shortened for less compression bites. The jumper connector is pre-filled, eliminating an installation step. Each jumper connector has a center stop, making it easy to center the jumper on the conductor.

All Quick Compress Jumper Connectors are designed for limited tension use, maintaining a minimum of 40% of the ASTM rated strength of the conductor.

The end tapers of all compression accessories are supplied with a High Voltage finish for die size sections 12CD and above.

Ordering Instructions

Step 1: Assembly Catalog Number

Determine the assembly catalog number based on the conductor being used.

Example:

A jumper connector for 927.2 Greeley conductor, the complete catalog number is:

JC12

Notes:

1. Installation Instructions for Compression Joints are on page 271.
2. For more information on die selection and ordering instructions, see Tools and Equipment tab in this catalog.

CATALOG NUMBER	CONDUCTOR			DIE SIZE	TOTAL WEIGHT		DIMENSION L	
	CODE WORD	SIZE	DIAMETER		LBS	KG	IN	MM
		KCMIL	IN					
JC07	—	281.4	0.609	07CD	0.3	0.11	5.6	142
JC07	Butte	312.8	0.642	07CD	0.3	0.11	5.6	142
JC08	—	355.1	0.684	08CD	0.4	0.19	6.4	163
JC08	Canton	394.5	0.721	08CD	0.4	0.19	6.4	163
JC08	—	419.6	0.743	08CD	0.4	0.19	6.4	163
JC09	Cairo	465.4	0.783	09CD	0.6	0.27	7.2	183
JC09	—	503.6	0.814	09CD	0.6	0.27	7.2	183
JC10	Darien	559.5	0.858	10CD	0.8	0.37	8.0	203
JC10	—	587.2	0.879	10CD	0.8	0.37	8.0	203
JC10	—	634.9	0.914	10CD	0.8	0.37	8.0	203
JC10	—	649.5	0.928	10CD	0.8	0.37	8.0	203
JC10	Elgin	652.4	0.927	10CD	0.8	0.37	8.0	203
JC10	—	657.3	0.930	10CD	0.8	0.37	8.0	203
JC11	Flint	740.8	0.991	11CD	1.1	0.50	8.8	224
JC12	—	853.7	1.063	12CD	1.4	0.64	9.6	244
JC12	Greeley	927.2	1.108	12CD	1.4	0.64	9.6	244



Quick Compress Jumper Connector for AAAC and ACAR Conductor, JC Series (cont.)

CATALOG NUMBER	CONDUCTOR			DIE SIZE	TOTAL WEIGHT		DIMENSION L	
	CODE WORD	SIZE	DIAMETER		LBS	KG	IN	MM
		KCMIL	IN					
JC13	—	1024.5	1.165	13CD	1.7	0.77	10.4	264
JC13	—	1080.6	1.196	13CD	1.7	0.77	10.4	264
JC13	—	1108.6	1.212	13CD	1.7	0.77	10.4	264
JC14	—	1172.3	1.246	14CD	2.2	1.00	11.2	284
JC16	—	1534.0	1.427	16CD	3.3	1.50	12.8	325
JC16	—	1700.0	1.502	16CD	3.3	1.50	12.8	325
JC19	—	2303.5	1.750	19CD	5.4	2.45	15.2	386
JC19	—	2338.0	1.762	19CD	5.4	2.45	15.2	386
JC20	—	2493.0	1.821	20CD	6.4	2.90	16.0	406

QuickCompress®—AAAC & ACAR

Quick Compress Terminal for AAAC and ACAR Conductor, Straight, TS Series

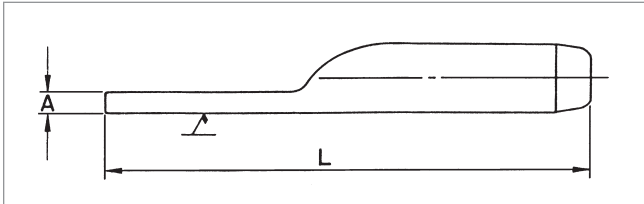

The TS Series Straight Terminal Connector is designed for fast and easy installation. By using a high strength alloy, the compression length has been shortened for less compression bites. The terminal connector is pre-filled, eliminating an installation step.

All TS Series connectors are designed for limited tension use, maintaining a minimum of 40% of the ASTM rated strength of the conductor.

The end tapers of all compression accessories are supplied with a High Voltage finish for die size sections 12CD and above.

The square edges of bolted pads of the compression accessories could cause Corona. Pads with edges and corners rounded can be supplied by adding the catalog suffix 'EHV'.

Ordering Instructions

Step 1: Catalog Number

Determine the catalog number based on the conductor being used.

Step 2: Extra High Voltage Finish

For Extra High Voltage Finish, use 'EHV'. (≥ 345 kV)

For Standard Finish, leave blank. (< 345 kV)

Step 3: Assemble Catalog Number.



Example:

A straight terminal for 927.7 Greeley with an EHV finish, the complete catalog number is:

TS12EHV

Notes:

1. Pad Dimensions are on page 257.
2. Installation Instructions for Terminals are on page 272.
3. Bolts, nuts and washers are not supplied with TS Series Terminal Connectors.
4. For more information on die selection and ordering instructions, see Tools and Equipment tab in this catalog.



Quick Compress Terminal for AAAC and ACAR Conductor, Straight, TS Series (cont.)

CATALOG NUMBER	CONDUCTOR			DIE SIZE	TOTAL WEIGHT		DIMENSION				PAD SIZE
	CODE WORD	SIZE	DIAMETER		LBS	KG	A		L		
		KCMIL	IN				IN	MM	IN	MM	
TS07	—	281.4	0.609	07CD	0.5	0.20	0.3	8	9.0	229	B
TS07	Butte	312.8	0.642	07CD	0.5	0.20	0.3	8	9.0	229	B
TS08	—	355.1	0.684	08CD	0.6	0.28	0.4	10	9.6	244	B
TS08	Canton	394.5	0.721	08CD	0.6	0.28	0.4	10	9.6	244	B
TS08	—	419.6	0.743	08CD	0.6	0.28	0.4	10	9.6	244	B
TS09	Cairo	465.4	0.783	09CD	0.8	0.38	0.4	11	10.0	254	B
TS09	—	503.6	0.814	09CD	0.8	0.38	0.4	11	10.0	254	B
TS10	Darien	559.5	0.858	10CD	1.1	0.50	0.5	12	10.6	269	B
TS10	—	587.2	0.879	10CD	1.1	0.50	0.5	12	10.6	269	B
TS10	—	634.9	0.914	10CD	1.1	0.50	0.5	12	10.6	269	B
TS10	—	649.5	0.928	10CD	1.1	0.50	0.5	12	10.6	269	B
TS10	Elgin	652.4	0.927	10CD	1.1	0.50	0.5	12	10.6	269	B
TS10	—	657.3	0.930	10CD	1.1	0.50	0.5	12	10.6	269	B
TS11	Flint	740.8	0.991	11CD	1.5	0.68	0.4	9	11.7	297	D
TS12	—	853.7	1.063	12CD	1.8	0.82	0.4	11	12.1	307	D
TS12	Greeley	927.2	1.108	12CD	1.8	0.82	0.4	11	12.1	307	D
TS13	—	1024.5	1.165	13CD	2.1	0.95	0.5	13	12.8	325	D
TS13	—	1080.6	1.196	13CD	2.1	0.95	0.5	13	12.8	325	D
TS13	—	1108.6	1.212	13CD	2.1	0.95	0.5	13	12.8	325	D
TS14	—	1172.3	1.246	14CD	2.7	1.22	0.6	16	13.8	351	D
TS16	—	1534.0	1.427	16CD	3.8	1.72	0.7	17	14.6	371	D
TS16	—	1700.0	1.502	16CD	3.8	1.72	0.7	17	14.6	371	D
TS19	—	2303.5	1.750	19CD	6.5	2.95	0.9	22	17.5	445	E
TS19	—	2338.0	1.762	19CD	6.5	2.95	0.9	22	17.5	445	E
TS20	—	2493.0	1.821	20CD	7.3	3.31	0.9	22	17.9	455	E

Quick Compress Terminal for AAAC and ACAR Conductor, 15°, TF Series

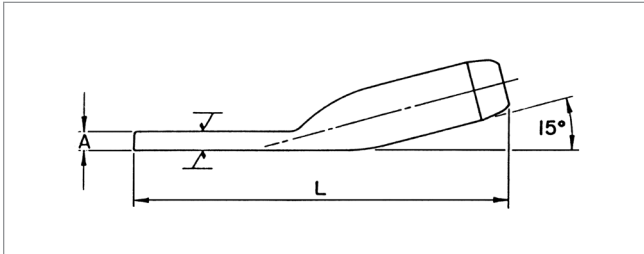

The TF Series 15° Terminal Connector is designed for fast and easy installation. By using a high strength alloy, the compression length has been shortened for less compression bites. The terminal connector is pre-filled, eliminating an installation step.

When used with the Quick Compress dead end, the TF Series connectors can be bolted in either straight or 30° position. All TF Series connectors are designed for limited tension use, maintaining a minimum of 40% of the ASTM rated strength of the conductor.

The end tapers of all compression accessories are supplied with a High Voltage finish for die size sections 12CD and above.

The square edges of bolted pads of the compression accessories could cause Corona. Pads with edges and corners rounded can be supplied by adding the catalog suffix 'EHV'.

Ordering Instructions

Step 1: Catalog Number

Determine the catalog number based on the conductor being used.

Step 2: Extra High Voltage Finish

For Extra High Voltage Finish, use 'EHV'. (≥ 345 kV)

For Standard Finish, leave blank. (< 345 kV)

Step 3: Assemble Catalog Number.

Catalog Number	+	EHV Finish
----------------	---	------------

Example:

A 15° terminal for 927.7 Greeley with an EHV finish, the complete catalog number is:

TF12EHV

Notes:

1. Pad Dimensions are on page 257.
2. Installation Instructions for Terminals are on page 272.
3. Bolts, nuts and washers are supplied with TF Series Terminal Connectors.
4. For more information on die selection and ordering instructions, see Tools and Equipment tab in this catalog.



Quick Compress Terminal for AAAC and ACAR Conductor, 15°, TF Series (cont.)

CATALOG NUMBER	CONDUCTOR			DIE SIZE	TOTAL WEIGHT		DIMENSIONS				PAD SIZE
	CODE WORD	SIZE	DIAMETER		LBS	KG	A		L		
		KCMIL	IN				IN	MM	IN	MM	
TF07	—	281.4	0.609	07CD	0.5	0.24	0.3	8	7.8	196	B
TF07	Butte	312.8	0.642	07CD	0.5	0.24	0.3	8	7.8	196	B
TF08	—	355.1	0.684	08CD	0.7	0.31	0.4	10	8.3	211	B
TF08	Canton	394.5	0.721	08CD	0.7	0.31	0.4	10	8.3	211	B
TF08	—	419.6	0.743	08CD	0.7	0.31	0.4	10	8.3	211	B
TF09	Cairo	465.4	0.783	09CD	0.9	0.40	0.4	11	8.9	226	B
TF09	—	503.6	0.814	09CD	0.9	0.40	0.4	11	8.9	226	B
TF10	Darien	559.5	0.858	10CD	1.1	0.50	0.5	12	9.4	239	B
TF10	—	587.2	0.879	10CD	1.1	0.50	0.5	12	9.4	239	B
TF10	—	634.9	0.914	10CD	1.1	0.50	0.5	12	9.4	239	B
TF10	—	649.5	0.928	10CD	1.1	0.50	0.5	12	9.4	239	B
TF10	Elgin	652.4	0.927	10CD	1.1	0.50	0.5	12	9.4	239	B
TF10	—	657.3	0.930	10CD	1.1	0.50	0.5	12	9.4	239	B
TF11	Flint	740.8	0.991	11CD	1.5	0.68	0.4	9	10.4	264	D
TF12	—	853.7	1.063	12CD	1.9	0.86	0.4	11	11.0	279	D
TF12	Greeley	927.2	1.108	12CD	1.9	0.86	0.4	11	11.0	279	D
TF13	—	1024.5	1.165	13CD	2.2	1.00	0.5	13	11.2	284	D
TF13	—	1080.6	1.196	13CD	2.2	1.00	0.5	13	11.2	284	D
TF13	—	1108.6	1.212	13CD	2.2	1.00	0.5	13	11.2	284	D
TF14	—	1172.3	1.246	14CD	2.8	1.27	0.6	16	12.0	305	D
TF16	—	1534.0	1.427	16CD	3.7	1.69	0.7	17	13.3	338	D
TF16	—	1700.0	1.502	16CD	3.7	1.69	0.7	17	13.3	338	D
TF19	—	2303.5	1.750	19CD	6.3	2.86	0.9	22	15.7	399	E
TF19	—	2338.0	1.762	19CD	6.3	2.86	0.9	22	15.7	399	E
TF20	—	2493.0	1.821	20CD	6.8	3.08	0.9	22	16.0	406	E

Quick Compress Terminal for AAAC and ACAR Conductor, 45°, T45 Series

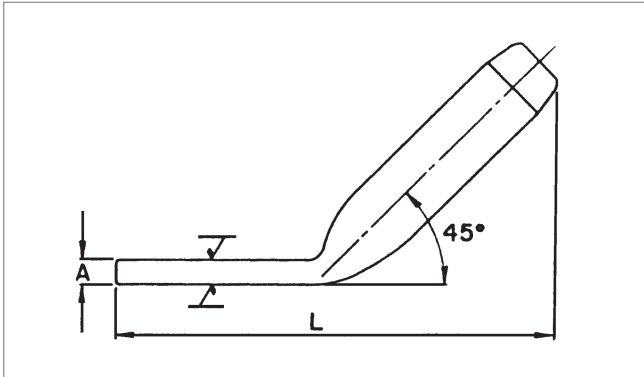

The T45 Series 45° Terminal Connector is designed for fast and easy installation. By using a high strength alloy, the compression length has been shortened for less compression bites. The terminal connector is pre-filled, eliminating an installation step. All T45 Series connectors are designed for limited tension use, maintaining a minimum of 40% of the ASTM rated strength of the conductor.

The end tapers of all compression accessories are supplied with a High Voltage finish for die size sections 12CD and above. The square edges of bolted pads of the compression accessories could cause Corona. Pads with edges and corners rounded can be supplied by adding the catalog suffix 'EHV'.

Ordering Instructions

Step 1: Catalog Number

Determine the catalog number based on the conductor being used.

Step 2: Extra High Voltage Finish

For Extra High Voltage Finish, use 'EHV'. (≥ 345 kV)

For Standard Finish, leave blank. (< 345 kV)

Step 3: Assemble Catalog Number.



Example:

A 45° terminal for 927.7 Greeley with an EHV finish, the complete catalog number is:

T4512EHV

Notes:

1. Pad Dimensions are on page 257.
2. Installation Instructions for Terminals are on page 272.
3. Bolts, nuts and washers are not supplied with T45 Series Terminal Connectors.
4. For more information on die selection and ordering instructions, see Tools and Equipment tab in this catalog.



Quick Compress Terminal for AAAC and ACAR Conductor, 45°, T45 Series (cont.)

CATALOG NUMBER	CONDUCTOR			DIE SIZE	TOTAL WEIGHT		DIMENSIONS				PAD SIZE
	CODE WORD	SIZE	DIAMETER		LBS	KG	A		L		
		KCMIL	IN				IN	MM	IN	MM	
T4507	—	281.4	0.609	07CD	0.4	0.19	0.3	8	7.3	185	B
T4507	Butte	312.8	0.642	07CD	0.4	0.19	0.3	8	7.3	185	B
T4508	—	355.1	0.684	08CD	0.6	0.25	0.4	10	7.8	198	B
T4508	Canton	394.5	0.721	08CD	0.6	0.25	0.4	10	7.8	198	B
T4508	—	419.6	0.743	08CD	0.6	0.25	0.4	10	7.8	198	B
T4509	Cairo	465.4	0.783	09CD	0.8	0.34	0.4	11	8.2	208	B
T4509	—	503.6	0.814	09CD	0.8	0.34	0.4	11	8.2	208	B
T4510	Darien	559.5	0.858	10CD	1.0	0.45	0.5	12	8.6	218	B
T4510	—	587.2	0.879	10CD	1.0	0.45	0.5	12	8.6	218	B
T4510	—	634.9	0.914	10CD	1.0	0.45	0.5	12	8.6	218	B
T4510	—	649.5	0.928	10CD	1.0	0.45	0.5	12	8.6	218	B
T4510	Elgin	652.4	0.927	10CD	1.0	0.45	0.5	12	8.6	218	B
T4510	—	657.3	0.930	10CD	1.0	0.45	0.5	12	8.6	218	B
T4511	Flint	740.8	0.991	11CD	1.3	0.59	0.4	9	9.4	239	D
T4512	—	853.7	1.063	12CD	1.6	0.73	0.4	11	9.7	246	D
T4512	Greeley	927.2	1.108	12CD	1.6	0.73	0.4	11	9.7	246	D
T4513	—	1024.5	1.165	13CD	2.0	0.91	0.5	13	10.2	259	D
T4513	—	1080.6	1.196	13CD	2.0	0.91	0.5	13	10.2	259	D
T4513	—	1108.6	1.212	13CD	2.0	0.91	0.5	13	10.2	259	D
T4514	—	1172.3	1.246	14CD	2.3	1.04	0.6	16	10.6	269	D
T4516	—	1534.0	1.427	16CD	3.4	1.54	0.7	17	11.0	279	D
T4516	—	1700.0	1.502	16CD	3.4	1.54	0.7	17	11.0	279	D
T4519	—	2303.5	1.750	19CD	5.7	2.59	0.9	22	13.7	348	E
T4519	—	2338.0	1.762	19CD	5.7	2.59	0.9	22	13.7	348	E
T4520	—	2493.0	1.821	20CD	6.5	2.95	0.9	22	14.2	361	E

QuickCompress®—AAAC & ACAR

Quick Compress Terminal for AAAC and ACAR Conductor, 90°, TN Series

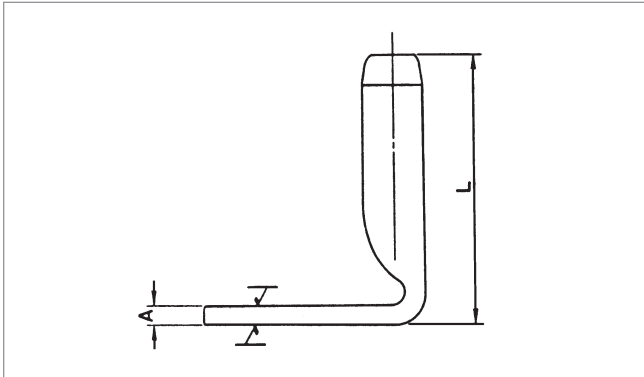

The TN Series 90° Terminal Connector is designed for fast and easy installation. By using a high strength alloy, the compression length has been shortened for less compression bites. The terminal connector is pre-filled, eliminating an installation step.

All TN Series connectors are designed for limited tension use, maintaining a minimum of 40% of the ASTM rated strength of the conductor.

The end tapers of all compression accessories are supplied with a High Voltage finish for die size sections 12CD and above.

The square edges of bolted pads of the compression accessories could cause Corona. Pads with edges and corners rounded can be supplied by adding the catalog suffix 'EHV'.

Ordering Instructions

Step 1: Catalog Number

Determine the catalog number based on the conductor being used.

Step 2: Extra High Voltage Finish

For Extra High Voltage Finish, use 'EHV'. (≥ 345 kV)

For Standard Finish, leave blank. (< 345 kV)

Step 3: Assemble Catalog Number.



Example:

A 90° terminal for 927.7 Greeley with an EHV finish, the complete catalog number is:

TN12EHV

Notes:

1. Pad Dimensions are on page 257.
2. Installation Instructions for Terminals are on page 272.
3. Bolts, nuts and washers are not supplied with TN Series Terminal Connectors.
4. For more information on die selection and ordering instructions, see Tools and Equipment tab in this catalog.



Quick Compress Terminal for AAAC and ACAR Conductor, 90°, TN Series (cont.)

CATALOG NUMBER	CONDUCTOR			DIE SIZE	TOTAL WEIGHT		DIMENSIONS				PAD SIZE
	CODE WORD	SIZE	DIAMETER		LBS	KG	A		L		
		KCMIL	IN				IN	MM	IN	MM	
TN07	—	281.4	0.609	07CD	0.5	0.20	0.3	8	5.2	132	B
TN07	Butte	312.8	0.642	07CD	0.5	0.20	0.3	8	5.2	132	B
TN08	—	355.1	0.684	08CD	0.6	0.29	0.4	10	5.7	145	B
TN08	Canton	394.5	0.721	08CD	0.6	0.29	0.4	10	5.7	145	B
TN08	—	419.6	0.743	08CD	0.6	0.29	0.4	10	5.7	145	B
TN09	Cairo	465.4	0.783	09CD	0.8	0.38	0.4	11	6.2	157	B
TN09	—	503.6	0.814	09CD	0.8	0.38	0.4	11	6.2	157	B
TN10	Darien	559.5	0.858	10CD	1.1	0.50	0.5	12	6.7	170	B
TN10	—	587.2	0.879	10CD	1.1	0.50	0.5	12	6.7	170	B
TN10	—	634.9	0.914	10CD	1.1	0.50	0.5	12	6.7	170	B
TN10	—	649.5	0.928	10CD	1.1	0.50	0.5	12	6.7	170	B
TN10	Elgin	652.4	0.927	10CD	1.1	0.50	0.5	12	6.7	170	B
TN10	—	657.3	0.930	10CD	1.1	0.50	0.5	12	6.7	170	B
TN11	Flint	740.8	0.991	11CD	1.4	0.64	0.4	9	7.5	191	D
TN12	—	853.7	1.063	12CD	1.8	0.82	0.4	11	7.9	202	D
TN12	Greeley	927.2	1.108	12CD	1.8	0.82	0.4	11	7.9	202	D
TN13	—	1024.5	1.165	13CD	2.2	1.00	0.5	13	8.5	216	D
TN13	—	1080.6	1.196	13CD	2.2	1.00	0.5	13	8.5	216	D
TN13	—	1108.6	1.212	13CD	2.2	1.00	0.5	13	8.5	216	D
TN14	—	1172.3	1.246	14CD	2.6	1.18	0.6	16	9.2	233	D
TN16	—	1534.0	1.427	16CD	3.7	1.68	0.7	17	10.2	259	D
TN16	—	1700.0	1.502	16CD	3.7	1.68	0.7	17	10.2	259	D
TN19	—	2303.5	1.750	19CD	6.1	2.77	0.9	22	11.9	303	E
TN19	—	2338.0	1.762	19CD	6.1	2.77	0.9	22	11.9	303	E
TN20	—	2493.0	1.821	20CD	6.9	3.13	0.9	22	12.6	321	E

QuickCompress®—AAAC & ACAR

Quick Compress Tee Connector for AAAC and ACAR Conductor, Open Run, TTOC Series

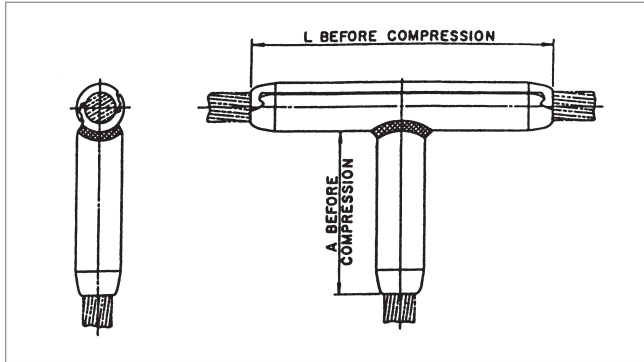

The TTOC Series Open Run Tee Connector is a permanent drop specifically designed for ACSR, AAC, AAAC and ACAR conductors.

The end tapers of all compression accessories are supplied with a high voltage finish for die size sections 12CD and above.

Ordering Instructions

Step 1: Assembly Catalog Number

Determine the assembly catalog number based on the conductor being used.

Example:

A tee connector for 927.7 Greeley, the complete catalog number is:

TTOC12

Notes:

1. Tee Connectors are not prefilled with AFC.
2. Installation Instructions for Tee Connectors are on page 274.
3. For more information on die selection and ordering instructions, see Tools and Equipment tab in this catalog.

CATALOG NUMBER	CONDUCTOR			DIE SIZE	TOTAL WEIGHT		DIMENSIONS			
	CODE WORD	SIZE	DIAMETER		LBS	KG	A		L	
		KCMIL	IN				IN	MM	IN	MM
TTOC07	—	281.4	0.609	07CD	0.5	0.22	3.9	100	6.4	163
TTOC07	Butte	312.8	0.642	07CD	0.5	0.22	3.9	100	6.4	163
TTOC08	—	355.1	0.684	08CD	0.7	0.32	4.4	111	7.2	183
TTOC08	Canton	394.5	0.721	08CD	0.7	0.32	4.4	111	7.2	183
TTOC08	—	419.6	0.743	08CD	0.7	0.32	4.4	111	7.2	183
TTOC09	Cairo	465.4	0.783	09CD	1.0	0.45	4.8	122	7.9	199
TTOC09	—	503.6	0.814	09CD	1.0	0.45	4.8	122	7.9	199
TTOC10	Darien	559.5	0.858	10CD	1.3	0.59	5.3	133	8.5	216
TTOC10	—	587.2	0.879	10CD	1.3	0.59	5.3	133	8.5	216
TTOC10	—	634.9	0.914	10CD	1.3	0.59	5.3	133	8.5	216
TTOC10	—	649.5	0.928	10CD	1.3	0.59	5.3	133	8.5	216
TTOC10	Elgin	652.4	0.927	10CD	1.3	0.59	5.3	133	8.5	216
TTOC10	—	657.3	0.930	10CD	1.3	0.59	5.3	133	8.5	216
TTOC11	Flint	740.8	0.991	11CD	1.7	0.77	5.7	145	9.2	234
TTOC12	—	853.7	1.063	12CD	2.1	0.95	6.1	155	9.9	250
TTOC12	Greeley	927.2	1.108	12CD	2.1	0.95	6.1	155	9.9	250
TTOC13	—	1024.5	1.165	13CD	2.9	1.32	6.6	167	10.6	269
TTOC13	—	1080.6	1.196	13CD	2.9	1.32	6.6	167	10.6	269
TTOC13	—	1108.6	1.212	13CD	2.9	1.32	6.6	167	10.6	269
TTOC14	—	1172.3	1.246	14CD	3.5	1.59	7.0	178	11.2	285
TTOC16	—	1534.0	1.427	16CD	5.0	2.27	7.8	198	12.5	316
TTOC16	—	1700.0	1.502	16CD	5.0	2.27	7.8	198	12.5	316
TTOC19	—	2303.5	1.750	19CD	8.0	3.63	9.1	230	14.4	364
TTOC19	—	2338.0	1.762	19CD	8.0	3.63	9.1	230	14.4	364
TTOC20	—	2493.0	1.821	20CD	9.2	4.17	9.4	240	14.9	378

Quick Compress Tee Tap for AAAC and ACAR Conductor, Open Run, TTOP Series

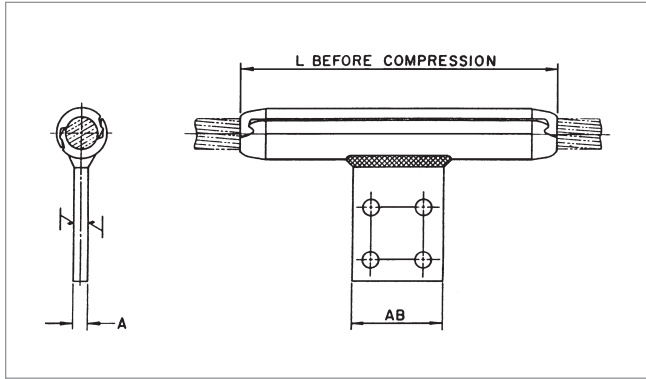

The TTOP Series Open Run Tee Tap is a permanent or temporary drop. By using a high strength alloy, the compression length has been shortened for less compression bites.

The run portion incorporates an improved design of interlocking extrusions, providing a permanent grip on the conductor when compressed.

The end tapers of all compression accessories are supplied with a High Voltage finish for die size sections 12CD and above.

The square edges of bolted pads of the compression accessories could cause Corona. Pads with edges and corners rounded can be supplied by adding the catalog suffix 'EHV'.

Ordering Instructions

Step 1: Assembly Catalog Number

Determine the assembly catalog number based on the conductor being used.

Step 2: Extra High Voltage Finish

For Extra High Voltage Finish, use 'EHV'. (≥ 345 kV)

For Standard Finish, leave blank. (< 345 kV)

Step 3: Assemble Catalog Number.

Assy Catalog Number	+	EHV Finish
------------------------	---	---------------

Example:

A tee tap for 927.7 Greeley with EHV finish, the complete catalog number is:

TTOP12EHV

Notes:

1. Installation Instructions for Tee Taps are on page 274.
2. For more information on die selection and ordering instructions, see Tools and Equipment tab in this catalog.



Quick Compress Tee Tap for AAAC and ACAR Conductor, Open Run, TTOP Series (cont.)

CATALOG NUMBER	CONDUCTOR			DIE SIZE	WEIGHT		DIMENSIONS						PAD SIZE
	CODE WORD	SIZE	DIAMETER		ALUMINUM		A		L		AB		
		KCMIL	IN		LBS	KG	IN	MM	IN	MM	IN	MM	
TTOP07	—	281.4	0.609	07CD	0.6	0.27	0.4	10	7.4	187	2.0	51	B
TTOP07	Butte	312.8	0.642	07CD	0.6	0.27	0.4	10	7.4	187	2.0	51	B
TTOP08	—	355.1	0.684	08CD	0.7	0.34	0.4	10	8.0	202	2.0	51	B
TTOP08	Canton	394.5	0.721	08CD	0.7	0.34	0.4	10	8.0	202	2.0	51	B
TTOP08	—	419.6	0.743	08CD	0.7	0.34	0.4	10	8.0	202	2.0	51	B
TTOP09	Cairo	465.4	0.783	09CD	0.9	0.41	0.4	10	8.5	215	2.0	51	B
TTOP09	—	503.6	0.814	09CD	0.9	0.41	0.4	10	8.5	215	2.0	51	B
TTOP10	Darien	559.5	0.858	10CD	1.0	0.45	0.4	10	9.0	229	2.0	51	B
TTOP10	—	587.2	0.879	10CD	1.0	0.45	0.4	10	9.0	229	2.0	51	B
TTOP10	—	634.9	0.914	10CD	1.0	0.45	0.4	10	9.0	229	2.0	51	B
TTOP10	—	649.5	0.928	10CD	1.0	0.45	0.4	10	9.0	229	2.0	51	B
TTOP10	Elgin	652.4	0.927	10CD	1.0	0.45	0.4	10	9.0	229	2.0	51	B
TTOP10	—	657.3	0.930	10CD	1.0	0.45	0.4	10	9.0	229	2.0	51	B
TTOP11	Flint	740.8	0.991	11CD	1.7	0.77	0.5	13	10.5	267	3.0	76	D
TTOP12	—	853.7	1.063	12CD	2.0	0.91	0.5	13	11.1	281	3.0	76	D
TTOP12	Greeley	927.2	1.108	12CD	2.0	0.91	0.5	13	11.1	281	3.0	76	D
TTOP13	—	1024.5	1.165	13CD	2.4	1.09	0.5	13	11.6	294	3.0	76	D
TTOP13	—	1080.6	1.196	13CD	2.4	1.09	0.5	13	11.6	294	3.0	76	D
TTOP13	—	1108.6	1.212	13CD	2.4	1.09	0.5	13	11.6	294	3.0	76	D
TTOP14	—	1172.3	1.246	14CD	2.8	1.27	0.5	13	12.1	307	3.0	76	D
TTOP16	—	1534.0	1.427	16CD	3.7	1.68	0.5	13	13.2	334	3.0	76	D
TTOP16	—	1700.0	1.502	16CD	3.7	1.68	0.5	13	13.2	334	3.0	76	D
TTOP19	—	2303.5	1.750	19CD	6.5	2.95	0.8	19	15.5	393	4.0	102	E
TTOP19	—	2338.0	1.762	19CD	6.5	2.95	0.8	19	15.5	393	4.0	102	E
TTOP20	—	2493.0	1.821	20CD	7.2	3.27	0.8	19	15.9	403	4.0	102	E



Quick Compress®

QuickCompress® – AAAC & ACAR

Quick Compress Dead Ends for Alumoweld® and Steel Ground Wire – GWDE Series

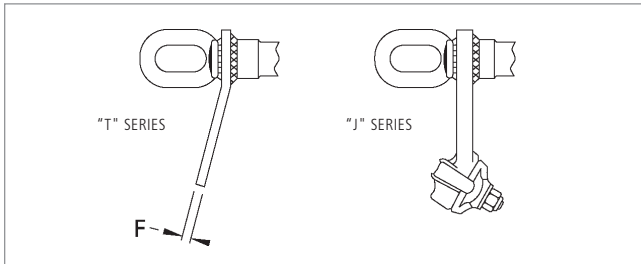
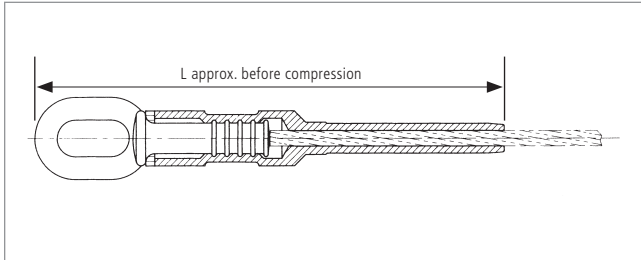

The Quick Compress GWDE Series Dead Ends are designed for fast and easy installation of Alumoweld® and Steel Ground Wire. By using a high strength alloy, the compression length has been shortened for less compression bites while maintaining a minimum of 95% of the ASTM rated strength. The steel eye is precompressed and the dead end is prefilled, eliminating installation steps.

Ordering Instructions

Step 1: Assembly Catalog Number

Determine the assembly catalog number based on the cable being used.

Step 2: Steel Eye Orientation

For an assembly with a vertical eye, use prefix 'V'.
For an assembly with a horizontal eye, use prefix 'H'.

Step 3: Tongue or Bolted Jumper

For an assembly with a tongue, use suffix 'T'.
For an assembly with a bolted jumper, use suffix 'J'.
For no tongue or bolted jumper, leave blank

Step 4: Assemble Catalog Number.



Example:

For a vertical eye dead end with a bolted jumper for 7 No. 10 Alumoweld, the complete catalog number is:

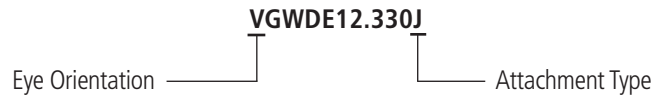

Notes:

1. For Alumoweld® wire specifications, see the AFL Wire Products catalog.
2. Installation instructions for GW series dead ends are on page 267.
3. For more information on die selection and ordering instructions, see Tools and Equipment section in this catalog.

Quick Compress Dead Ends for Alumoweld® and Steel Ground Wire – GWDE Series (cont.)

ASSEMBLY CATALOG NUMBER	CONDUCTOR		DIMENSIONS				JUMPER DIAMETER RANGE J SERIES		DIE SIZE	GWDE SERIES		GWDE-T SERIES		GWDE-J SERIES	
	SIZE	DIAM-ETER	L		F		IN	MM		TOTAL WEIGHT		TOTAL WEIGHT		TOTAL WEIGHT	
			IN	MM	IN	MM				LBS	KG	LBS	KG	LBS	KG
ALUMOWELD®															
GWDE10.251	3 No. 10	0.220	10.4	264	0.5	13	0.162-0.327	4.1-8.3	6010GW	0.7	0.34	1.2	0.54	1.1	0.50
GWDE10.281	3 No. 9	0.247	10.4	264	0.5	13	0.162-0.327	4.1-8.3	6010GW	0.7	0.34	1.2	0.54	1.1	0.50
GWDE10.295	3 No. 8	0.277	10.8	274	0.5	13	0.277-0.625	7.0-15.9	6010GW	0.7	0.34	1.2	0.54	2.2	1.00
GWDE10.324	3 No. 7	0.311	11.3	287	0.5	13	0.277-0.625	7.0-15.9	6010GW	0.8	0.34	1.2	0.54	2.2	1.00
GWDE12.351	3 No. 6	0.349	12.4	315	0.5	13	0.277-0.625	7.0-15.9	6012GW	1.4	0.64	1.9	0.86	2.4	1.09
GWDE14.406	3 No. 5	0.392	12.6	321	0.5	13	0.277-0.625	7.0-15.9	6014GW	1.9	0.86	2.4	1.08	2.9	1.31
GWDE12.330	7 No. 10	0.306	11.2	284	0.5	13	0.277-0.625	7.0-15.9	6012GW	1.4	0.64	1.9	0.86	2.4	1.09
GWDE12.359	7 No. 9	0.343	12.4	315	0.5	13	0.277-0.625	7.0-15.9	6012GW	1.4	0.64	1.9	0.86	2.4	1.09
GWDE14.406	7No. 8	0.385	12.6	321	0.5	13	0.277-0.625	7.0-15.9	6014GW	1.9	0.86	2.4	1.08	2.9	1.31
GWDE16.484	7 No. 7	0.433	13.2	335	0.5	13	0.277-0.625	7.0-15.9	6016GW	2.1	0.95	2.6	1.18	3.1	1.41
GWDE16.531	7 No. 6	0.486	15.8	400	0.6	16	0.277-0.625	7.0-15.9	6016GW	3.9	1.77	4.8	2.18	4.8	2.18
GWDE18.594	7 No. 5	0.546	15.7	399	0.6	16	0.464-0.742	11.8-18.9	6018GW	4.0	1.81	4.9	2.22	4.9	2.22
GWDE18.530	19 No. 10	0.509	15.7	399	0.6	16	0.464-0.743	11.8-18.9	6018GW	4.0	1.81	4.9	2.22	4.9	2.22
STEEL GROUND WIRE															
GWDE12.332	5/16" EHS	0.312	12.3	313	0.5	13	0.277-0.625	7.0-15.9	6012GW	1.4	0.64	1.9	0.86	2.4	1.09
GWDE14.386	3/8" EHS	0.360	14.3	362	0.5	13	0.277-0.625	7.0-15.9	6014GW	2.1	0.95	2.6	1.18	3.0	1.35
GWDE16.453	7/16" EHS	0.435	15.0	381	0.5	13	0.277-0.625	7.0-15.9	6016GW	2.2	1.00	2.7	1.22	3.2	1.45
GWDE18.531	1/2" EHS	0.495	18.7	475	0.6	16	0.464-0.743	11.8-18.9	6018GW	4.3	1.95	5.2	2.36	5.2	2.36

Quick Compress Dead Ends GWDE Series (cont.) Steel Eye Dimensions

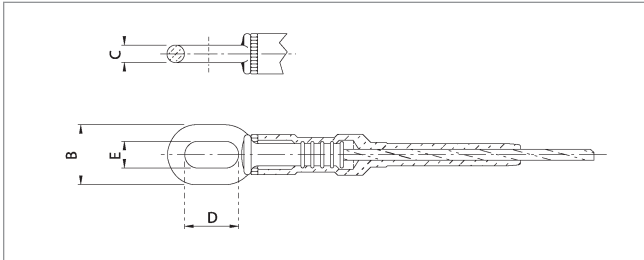

ASSEMBLY CATALOG NUMBER	CONDUCTOR SIZE	DIMENSIONS							
		B		C		D		E	
		IN	MM	IN	MM	IN	MM	IN	MM
ALUMOWELD®									
GWDE10.251	3 No. 10	2.2	57	0.6	16	2.0	51	1.0	25
GWDE10.281	3 No. 9	2.0	52	0.5	13	2.0	51	1.0	25
GWDE10.295	3 No. 8	1.8	46	0.4	10	2.0	51	1.0	25
GWDE10.324	3 No. 7	1.8	46	0.4	10	2.0	51	1.0	25
GWDE12.351	3 No. 6	1.8	46	0.4	10	2.0	51	1.0	25
GWDE14.406	3 No. 7	1.8	46	0.4	10	2.0	51	1.0	25
GWDE12.330	7 No. 10	2.8	71	0.8	20	2.5	64	1.2	31
GWDE12.359	7 No. 9	2.8	71	0.8	20	2.5	64	1.2	31
GWDE14.406	7 No. 8	2.2	57	0.6	16	2.0	51	1.0	25
GWDE16.484	7 No. 7	2.2	57	0.6	16	2.0	51	1.0	25
GWDE16.531	7 No. 6	2.0	52	0.5	13	2.0	51	1.0	25
GWDE18.594	7 No. 5	2.0	52	0.5	13	2.0	51	1.0	25
GWDE18.530	19 No. 10	2.8	71	0.8	20	2.5	64	1.2	31
STEEL GROUND WIRE									
GWDE12.332	5/16" EHS	2.0	52	0.5	13	2.0	51	1.0	25
GWDE14.386	3/8" EHS	2.2	57	0.6	16	2.0	51	1.0	25
GWDE16.453	7/16" EHS	2.2	57	0.6	16	2.0	51	1.0	25
GWDE18.531	1/2" EHS	2.8	71	0.8	20	2.5	64	1.2	31

Quick Compress Compression Joints for Alumoweld® and Steel Ground Wire, GWJ Series

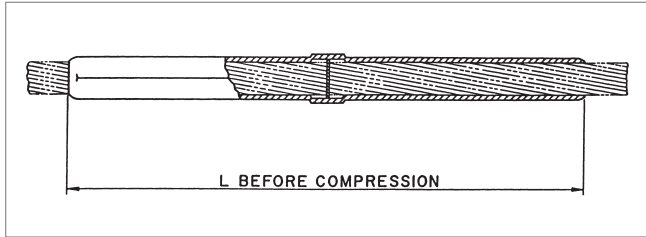

The Quick Compress GWJ Series Joints are designed for fast and easy installation of Alumoweld® and Steel Ground Wire. By using a high strength alloy, the compression length has been shortened for less compression bites while maintaining a minimum 95% of the ASTM rated strength. The compression joint is pre-filled, eliminating an installation step. Each compression joint has a center stop to ensure proper insertion of the conductor.

Ordering Instructions

Step 1: Assembly Catalog Number

Determine the assembly catalog number based on the conductor being used.

Example:

A compression joint for No. 10 Alumoweld®, the complete catalog number is:

GWJ12.330

Notes:

1. Installation Instructions for Compression Joints are on page 268.
2. For more information on die selection and ordering instructions, see Tools and Equipment section in this catalog.

CATALOG NUMBER	CONDUCTOR			DIMENSION L		DIE SIZE	TOTAL WEIGHT	
	SIZE	DIAMETER		IN	MM		LBS	KG
		IN	MM					
ALUMOWELD®								
GWJ10.251	3 No. 10	0.220	5.6	6.62	168	6010GW	0.17	0.08
GWJ10.281	3 No. 9	0.247	6.3	6.62	168	6010GW	0.16	0.07
GWJ10.295	3 No. 8	0.277	7.0	7.50	191	6010GW	0.17	0.08
GWJ10.324	3 No. 7	0.311	7.9	7.50	191	6010GW	0.16	0.07
GWJ12.351	3 No. 6	0.349	8.9	9.00	229	6012GW	0.27	0.12
GWJ14.406	3 No. 5	0.392	10.0	8.25	210	6014GW	0.38	0.17
GWJ12.330	7 No. 10	0.306	7.8	6.50	165	6012GW	0.23	0.1
GWJ12.359	7 No. 9	0.343	8.7	9.00	229	6012GW	0.27	0.12
GWJ14.406	7 No. 8	0.385	9.8	8.25	210	6014GW	0.38	0.17
GWJ16.484	7 No. 7	0.433	11.0	9.62	244	6016GW	0.58	0.26
GWJ16.531	7 No. 6	0.486	12.3	11.00	279	6016GW	0.62	0.28
GWJ18.594	7 No. 5	0.546	13.9	11.00	279	6018GW	0.73	0.33
GWJ18.530	19 No. 10	0.509	12.9	11.00	279	6018GW	0.83	0.38
STEEL GROUND WIRE								
GWJ12.332	5/16" EHS GW	0.312	7.90	8.81	224	6012GW	0.31	0.14
GWJ14.386	3/8" EHS GW	0.360	9.10	10.50	267	6014GW	0.49	0.22
GWJ16.453	7/16" EHS GW	0.435	11.00	13.25	337	6016GW	0.73	0.33
GWJ18.531	1/2" EHS GW	0.495	12.60	17.00	432	6018GW	1.30	0.59

NEMA Standard Pad Sizes

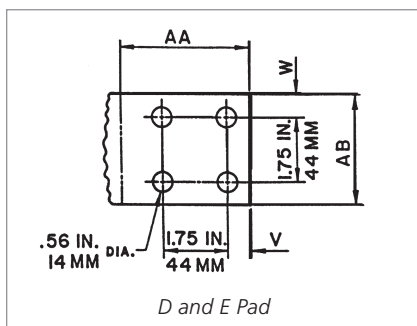
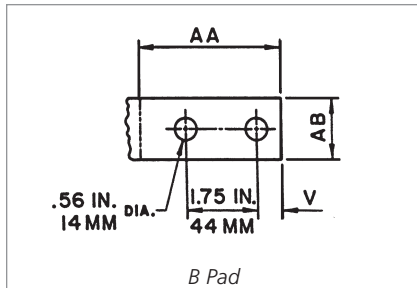

DIGITS OF CATALOG NUMBER	PAD LETTER	DIMENSIONS								PAD THICKNESS DEAD END TONGUE	
		V		W		AA		AB		IN	MM
		IN	MM	IN	MM	IN	MM	IN	MM		
07	B	0.62	16	—	—	3.50	89	1.50	38	0.50	13
08	B	0.62	16	—	—	3.50	89	1.70	43	0.50	13
09	B	0.62	16	—	—	3.50	89	1.92	49	0.50	13
10	B	0.62	16	—	—	3.50	89	2.18	55	0.50	13
11-16	D	0.62	16	0.62	16	3.50	89	3.00	76	0.62	16
17-20	E	1.12	29	1.12	29	4.00	102	4.00	102	0.75	19

Notes:

1. If the catalog number has 'EHV' suffix, pad will be furnished with rounded corners.
2. 15° terminals and dead end tongues are finished on both sides.

Steel Eye and Clevis Dimensions – Non-Adjustable Steel Eye

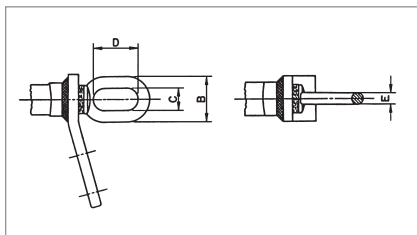

DIGITS OF CATALOG NUMBER	DIMENSIONS							
	B		C		D		E	
	IN	MM	IN	MM	IN	MM	IN	MM
07 and 08	1.82	46	1.00	25	2.00	51	0.41	10
09 and 10	2.04	52	1.00	25	2.00	51	0.52	13
11 and 12	2.24	57	1.00	25	2.00	51	0.62	18
13-15	2.80	71	1.24	31	2.50	64	0.78	20
16-18	3.12	79	1.24	31	2.50	64	0.94	24
19 and 20	3.70	94	1.50	38	3.00	76	1.10	28

Bolt Sizes and Recommended Torque

15° TERMINAL SIZE	BOLT SIZE	RECOMMENDED TORQUE: LB-FT	RECOMMENDED TORQUE: N-M
TF07, TF08, TF09	1/2" -13UNC x 1.75"	25	34
TF10, TF11, TF12, TF13	1/2" -13UNC x 2.00"	25	34
TF14, TF15, TF16, TF16, TF17	1/2" -13UNC x 2.25"	25	34
TF18, TF19, TF20	1/2" -13UNC x 2.50"	25	34

Steel Eye and Clevis Dimensions – Adjustable Steel Clevis

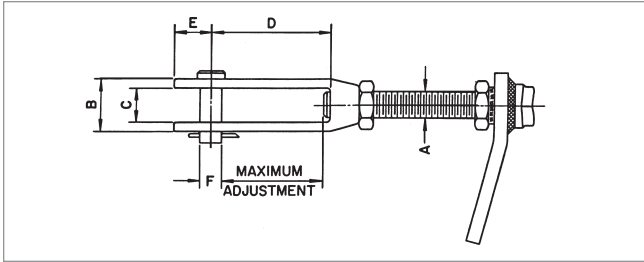

DIGITS OF CATALOG NUMBER	DIMENSIONS											MAXIMUM ADJUSTMENT	
	A	B		C		D		E		F		IN	MM
		IN	MM	IN	MM	IN	MM	IN	MM	IN	MM		
07	5/8-11	1.56	40	0.75	19	4.00	102	1.25	32	0.62	16	3.38	86
08	3/4-10	1.69	43	0.88	22	4.00	102	1.25	32	0.62	16	3.38	86
9 and 10	7/8-9	1.81	46	1.00	25	4.00	102	1.25	32	0.75	19	3.38	86
11 and 12	1-8	2.56	65	1.38	35	5.00	127	1.50	38	0.88	22	4.25	108
13-15	1 1/4-7	2.56	65	1.38	35	5.00	127	1.50	38	1.00	25	4.25	108
16-18	1 1/2-6	2.81	71	1.62	41	6.00	152	1.75	44	1.12	28	5.12	130
19 and 20	1 3/4-5	3.19	81	2.00	51	6.00	152	2.00	51	1.25	32	5.12	130

Steel Eye and Clevis Dimensions – Adjustable Steel Eye

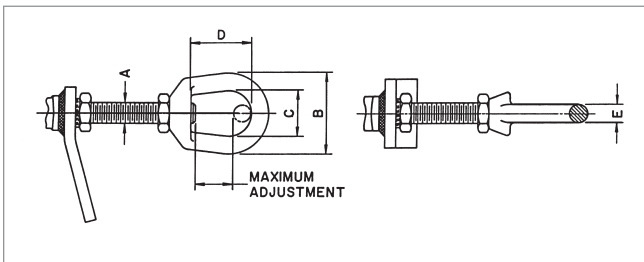

DIGITS OF CATALOG NUMBER	DIMENSIONS										MAXIMUM ADJUSTMENT	
	A	B		C		D		E		IN	MM	
		IN	MM	IN	MM	IN	MM	IN	MM			
07	5/8-11	2.50	64	1.50	38	2.00	51	0.50	13	1.28	33	
08	3/4-10	3.00	76	1.75	44	2.38	60	0.62	16	1.53	39	
09 and 10	7/8-9	3.50	89	2.00	51	2.62	67	0.75	19	1.63	41	
11 and 12	1-8	4.00	102	2.25	57	3.06	78	0.88	22	1.92	49	
13-15	1 1/4-7	4.50	114	2.50	64	3.50	89	1.00	25	2.23	57	
16-18	1 1/2-6	5.62	143	3.12	79	4.00	102	1.25	32	2.45	62	
19 and 20	1 3/4-5	5.62	143	3.12	79	4.00	102	1.25	32	2.17	55	

Conductor Information for ACSR Conductors

CODE NAME	SIZE	STRANDING	DIAMETER (INCHES)				WEIGHT PER 1000 FT	RATED STRENGTH	RESISTANCE OHMS PER 1000 FT		ALLOWABLE AMPACITY ¹	SAG10® CHART NUMBER
			INDIVIDUAL WIRES		STEEL CORE	COMPLETE CABLE			DC @ 20°C	AC @ 75°C		
			AL	ST								
Turkey	6	6/1	0.066	0.066	0.066	0.198	36	1,190	0.641	0.806	105	1-1023
Swan	4	6/1	0.083	0.083	0.083	0.250	57	1,860	0.403	0.515	140	1-1023
Swanate	4	7/1	0.077	0.103	0.103	0.257	67	2,360	0.399	0.519	140	1-670
Sparrow	2	6/1	0.105	0.105	0.105	0.316	91	2,850	0.254	0.332	184	1-1023
Sparate	2	7/1	0.097	0.130	0.130	0.325	107	3,460	0.251	0.338	184	1-670
Robin	1	6/1	0.118	0.118	0.118	0.354	115	3,550	0.201	0.268	212	1-938
Raven	1/0	6/1	0.133	0.133	0.133	0.398	145	4,380	0.159	0.217	242	1-938
Quail	2/0	6/1	0.149	0.149	0.149	0.447	183	5,310	0.126	0.176	276	1-938
Pigeon	3/0	6/1	0.167	0.167	0.167	0.502	231	6,620	0.100	0.144	315	1-938
Penguin	4/0	6/1	0.188	0.188	0.188	0.563	291	8,350	0.080	0.119	357	1-938
Waxwing	266.8	18/1	0.122	0.122	0.122	0.609	289	6,880	0.064	0.079	449	1-844
Partridge	266.8	26/7	0.101	0.079	0.236	0.642	367	11,300	0.064	0.078	475	1-782
Ostrich	300	26/7	0.107	0.084	0.251	0.680	412	12,700	0.057	0.069	492	1-782
Merlin	336.4	18/1	0.137	0.137	0.137	0.684	365	8,680	0.051	0.063	519	1-844
Linnet	336.4	26/7	0.114	0.089	0.265	0.720	462	14,100	0.051	0.062	529	1-782
Oriole	336.4	30/7	0.106	0.106	0.318	0.741	526	17,300	0.050	0.061	535	1-773
Chickadee	397.5	18/1	0.149	0.149	0.149	0.743	431	9,940	0.043	0.053	576	1-844
Brant	397.5	24/7	0.129	0.086	0.257	0.772	511	14,600	0.043	0.053	584	1-889
Ibis	397.5	26/7	0.124	0.096	0.289	0.783	546	16,300	0.043	0.052	587	1-782
Lark	397.5	30/7	0.115	0.115	0.345	0.806	622	20,300	0.043	0.052	594	1-773
Pelican	477	18/1	0.163	0.163	0.163	0.814	517	11,800	0.036	0.044	646	1-844
Flicker	477	24/7	0.141	0.094	0.282	0.846	614	17,200	0.036	0.044	655	1-889
Hawk	477	26/7	0.135	0.105	0.316	0.858	656	19,500	0.036	0.044	659	1-782
Hen	477	30/7	0.126	0.126	0.378	0.883	746	23,800	0.035	0.043	666	1-773
Osprey	556.5	18/1	0.176	0.176	0.176	0.879	603	13,700	0.031	0.038	711	1-844
Parakeet	556.5	24/7	0.152	0.102	0.305	0.914	716	19,800	0.031	0.038	721	1-889
Dove	556.5	26/7	0.146	0.114	0.341	0.927	765	22,600	0.031	0.038	726	1-782
Eagle	556.5	30/7	0.136	0.136	0.409	0.953	871	27,800	0.030	0.037	734	1-773
Peacock	605	24/7	0.159	0.106	0.318	0.953	779	21,600	0.028	0.035	760	1-889
Squab	605	26/7	0.153	0.119	0.356	0.966	832	24,300	0.028	0.035	765	1-782
Wood Duck	605	30/7	0.142	0.142	0.426	0.994	946	28,900	0.028	0.034	774	—
Teal	605	30/19	0.142	0.085	0.426	0.994	939	30,000	0.028	0.034	773	1-757
Kingbird	636	18/1	0.188	0.188	0.188	0.940	690	15,700	0.027	0.033	773	1-844
Swift	636	36/1	0.133	0.133	0.133	0.930	643	13,690	0.027	0.033	769	1-898
Rook	636	24/7	0.163	0.109	0.326	0.977	818	22,000	0.027	0.033	784	1-889
Grosbeak	636	26/7	0.156	0.122	0.365	0.991	874	25,200	0.027	0.033	789	1-782
Scoter	636	30/7	0.146	0.146	0.437	1.019	995	30,400	0.026	0.033	798	—

Conductor Information for ACSR Conductors (cont.)

CODE NAME	SIZE	STRANDING	DIAMETER (INCHES)				WEIGHT PER 1000 FT	RATED STRENGTH	RESISTANCE OHMS PER 1000 FT		ALLOWABLE AMPACITY ¹	SAG10® CHART NUMBER
			INDIVIDUAL WIRES		STEEL CORE	COMPLETE CABLE			DC @ 20°C	AC @ 75°C		
			AL	ST								
Egret	636	30/19	0.146	0.087	0.437	1.019	987	31,500	0.027	0.033	798	1-757
Flamingo	666.6	24/7	0.167	0.111	0.333	1.000	858	23,700	0.026	0.032	807	1-889
Gannet	666.6	26/7	0.160	0.125	0.374	1.014	916	26,400	0.026	0.031	812	1-782
Stilt	715.5	24/7	0.173	0.115	0.345	1.036	920	25,500	0.024	0.029	844	1-889
Starling	715.5	26/7	0.166	0.129	0.387	1.051	984	28,400	0.024	0.029	849	1-537
Redwing	715.5	30/19	0.154	0.093	0.463	1.081	1,110	34,600	0.024	0.029	859	1-757
Coot	795	36/1	0.149	0.149	0.149	1.040	804	16,710	0.022	0.027	884	1-898
Drake	795	26/7	0.175	0.136	0.408	1.107	1,093	31,500	0.021	0.026	907	1-537
Tern	795	45/7	0.133	0.089	0.266	1.063	895	22,100	0.022	0.027	887	1-955
Condor	795	54/7	0.121	0.121	0.364	1.092	1,023	28,200	0.022	0.027	889	1-838
Mallard	795	30/19	0.163	0.098	0.488	1.140	1,233	38,400	0.021	0.026	918	1-757
Ruddy	900	45/7	0.141	0.094	0.283	1.131	1,013	24,400	0.019	0.024	958	1-955
Canary	900	54/7	0.129	0.129	0.387	1.162	1,158	31,900	0.019	0.024	961	1-838
Rail	954	45/7	0.146	0.097	0.291	1.165	1,074	25,900	0.018	0.023	993	1-955
Cardinal	954	54/7	0.133	0.133	0.399	1.196	1,227	33,800	0.018	0.023	996	1-838
Ortolan	1033.5	45/7	0.152	0.101	0.303	1.212	1,163	27,700	0.017	0.021	1043	1-957
Curlew	1033.5	54/7	0.138	0.138	0.415	1.245	1,330	36,600	0.017	0.021	1047	1-838
Bluejay	1113	45/7	0.157	0.105	0.315	1.258	1,253	29,800	0.016	0.019	1092	1-957
Finch	1113	54/19	0.144	0.086	0.431	1.292	1,429	39,100	0.015	0.020	1093	1-1009
Bunting	1192.5	45/7	0.163	0.109	0.326	1.302	1,342	32,000	0.014	0.018	1139	1-957
Grackle	1192.5	54/19	0.149	0.089	0.446	1.337	1,531	41,900	0.014	0.018	1140	1-1009
Bittern	1272	45/7	0.168	0.112	0.336	1.345	1,432	34,100	0.014	0.017	1184	1-957
Pheasant	1272	54/19	0.154	0.092	0.461	1.381	1,633	34,600	0.014	0.017	1187	1-1009
Dipper	1351.5	45/7	0.173	0.116	0.347	1.386	1,521	36,200	0.013	0.016	1229	1-957
Martin	1351.5	54/19	0.158	0.095	0.475	1.424	1,735	46,300	0.013	0.016	1232	1-1009
Bobolink	1431	45/7	0.178	0.119	0.357	1.427	1,611	38,300	0.012	0.015	1272	1-957
Lapwing	1590	45/7	0.188	0.125	0.376	1.504	1,790	42,200	0.011	0.014	1354	1-1019
Falcon	1590	54/19	0.172	0.103	0.515	1.544	2,041	54,500	0.011	0.014	1359	1-1009
Chukar	1780	84/19	0.146	0.087	0.437	1.602	2,071	51,000	0.010	0.013	1453	1-1020
Bluebird	2156	84/19	0.160	0.096	0.481	1.762	2,509	60,300	0.008	0.011	1623	1-020
Kiwi	2167	72/7	0.174	0.116	0.347	1.735	2,300	49,800	0.008	0.011	1607	1-1053

Note:

Conductor temperature at 75°, ambient temperature 25°C, emissivity 0.5, wind 2 ft/sec, in sun.

Conductor Information for AAC Conductors

CODE NAME	SIZE	STRANDING	DIAMETER (INCHES)	WEIGHT PER 1000 FT	RATED STRENGTH	RESISTANCE OHMS PER 1000 FT		ALLOWABLE AMPACITY¹	SAG10® CHART NUMBER
	KCMIL		AL			COMPLETE CABLE	LBS		
Peachbell	6	7	0.184	25	563	0.658	0.805	103	1-918
Rose	4	7	0.232	39	881	0.414	0.506	138	1-918
Iris	2	7	0.292	62	1,350	0.260	0.318	185	1-918
Pansy	1	7	0.328	78	1,640	0.207	0.252	214	1-918
Poppy	1/0	7	0.368	99	1,990	0.164	0.200	247	1-918
Aster	2/0	7	0.414	125	2,510	0.130	0.159	286	1-918
Phlox	3/0	7	0.464	157	3,040	0.103	0.126	331	1-918
Oxlip	4/0	7	0.522	198	3,830	0.082	0.100	383	1-918
Sneezewort	250.0	7	0.567	234	4,520	0.069	0.085	425	1-918
Valerian	250.0	19	0.574	234	4,660	0.069	0.085	426	1-945
Daisy	266.8	7	0.586	250	4,830	0.065	0.079	443	1-918
Laurel	266.8	19	0.592	250	4,970	0.065	0.079	444	1-945
Peony	300.0	19	0.628	281	5,480	0.058	0.071	478	1-945
Tulip	336.4	19	0.665	315	6,150	0.051	0.063	513	1-945
Daffodil	350.0	19	0.679	328	6,390	0.049	0.061	526	1-945
Canna	397.5	19	0.723	373	7,110	0.044	0.053	570	1-945
Goldentuft	450.0	19	0.769	422	7,890	0.038	0.043	616	1-945
Cosmos	477.0	19	0.792	447	8,360	0.036	0.045	639	1-945
Syringa	477.0	37	0.795	447	8,690	0.036	0.045	639	1-1049
Zinnia	500.0	19	0.811	469	8,760	0.035	0.043	658	1-945
Hyacinth	500.0	37	0.814	469	9,110	0.035	0.043	658	1-1049
Dahlia	556.5	19	0.856	522	9,750	0.031	0.038	703	1-945
Mistletoe	556.5	37	0.858	522	9,940	0.031	0.038	704	1-1049
Meadowsweet	600.0	37	0.891	562	10,700	0.023	0.036	738	1-1049
Orchid	636.0	37	0.918	596	11,400	0.027	0.036	765	1-1049
Heuchera	650.0	37	0.928	609	11,600	0.027	0.033	775	1-1049
Verbena	700.0	37	0.963	656	12,500	0.025	0.031	812	1-1049
Flag	700.0	61	0.964	656	12,900	0.025	0.031	812	1-1010
Violet	715.5	37	0.973	671	12,800	0.024	0.030	823	1-1049
Nasturtium	715.5	61	0.975	671	13,100	0.024	0.030	823	1-1010
Petunia	750.0	37	0.997	703	13,100	0.023	0.029	847	1-1049
Cattail	750.0	61	0.998	703	13,500	0.023	0.029	847	1-1010
Arbutus	795.0	37	1.026	745	13,900	0.022	0.027	878	1-1049
Lilac	795.0	61	1.027	745	14,300	0.022	0.027	879	1-1010

Conductor Information for AAC Conductors (cont.)

CODE NAME	SIZE	STRANDING	DIAMETER (INCHES)	WEIGHT PER 1000 FT	RATED STRENGTH	RESISTANCE OHMS PER 1000 FT		ALLOWABLE AMPACITY ¹	SAG10® CHART NUMBER
	KCMIL		AL			COMPLETE CABLE	LBS		
Cockscomb	900.0	37	1.092	844	15,400	0.019	0.024	948	1-1049
Snapdragon	900.0	61	1.093	844	15,900	0.019	0.024	948	1-1010
Magnolia	954.0	37	1.124	894	16,400	0.018	0.023	982	1-1049
Goldenrod	954.0	61	1.125	894	16,900	0.018	0.023	983	1-1010
Hawkweed	1000.0	37	1.151	937	17,200	0.017	0.022	1,010	1-1049
Camellia	1000.0	61	1.152	937	17,700	0.071	0.022	1,011	1-1010
Bluebell	1033.5	37	1.170	969	17,700	0.017	0.021	1,031	1-1049
Larkspur	1033.5	61	1.171	969	18,300	0.017	0.021	1,032	1-1010
Marigold	1113.0	61	1.216	1,043	19,700	0.016	0.020	1,079	1-1010
Hawthorn	1192.5	61	1.258	1,118	21,100	0.015	0.018	1,124	1-1010
Narcissus	1272.0	61	1.300	1,192	22,000	0.014	0.017	1,169	1-1010
Columbine	1351.5	61	1.340	1,267	23,400	0.013	0.016	1,212	1-1010
Carnation	1431.0	61	1.378	1,341	24,300	0.012	0.016	1,253	1-1010
Gladiolus	1510.5	61	1.416	1,416	25,600	0.014	0.015	1,294	1-1010
Coreopsis	1590.0	61	1.453	1,490	27,000	0.011	0.014	1,333	1-1010
Jessamine	1750.0	61	1.524	1,640	29,700	0.010	0.013	1,408	1-1010
Cowslip	2000.0	91	1.631	1,875	34,200	0.009	0.012	1,518	1-1157
Sagebrush	2250.0	91	1.730	2,130	37,500	0.008	0.011	1,612	1-1157
Lupine	2500.0	91	1.823	2,366	41,900	0.007	0.010	1,706	1-1157
Bitterroot	2750.0	91	1.912	2,603	46,100	0.006	0.009	1,793	1-1157
Trillium	3000.0	127	1.998	2,839	50,300	0.006	0.008	1,874	1-1032
Bluebonnet	3500.0	127	2.158	3,345	58,700	0.005	0.008	2,024	1-1032

Note:

Conductor temperature at 75°, ambient temperature 25° C, emissivity 0.5, wind 2 ft/sec, in sun.



Conductor Information for AAAC Conductors

CODE NAME	SIZE	STRANDING	DIAMETER	WEIGHT PER 1000 FT	RATED STRENGTH	RESISTANCE		ALLOWABLE AMPACITY ¹	SAG10® CHART NUMBER
	KCMIL					AL	IN		
Akron	30.58	7	0.198	29	1,110	0.659	0.785	107	1-1068
Alton	48.69	7	0.250	45	1,760	0.414	0.493	143	1-1068
Ames	77.47	7	0.316	72.	2,800	0.260	0.310	191	1-1068
Azusa	123.3	7	0.398	115	4,460	0.163	0.195	256	1-1068
Anaheim	155.4	7	0.447	145	5,390	0.130	0.154	296	1-1068
Amherst	195.7	7	0.502	183	6,790	0.103	0.123	342	1-1068
Alliance	246.9	7	0.563	230	8,560	0.082	0.097	395	1-1068
Butte	312.8	19	0.642	292	11,000	0.064	0.077	460	1-1056
Canton	394.5	19	0.720	368	13,300	0.051	0.061	532	1-1056
Cairo	465.4	19	0.783	434	15,600	0.043	0.052	590	1-1056
Darien	559.5	19	0.858	522	18,800	0.036	0.043	663	1-1056
Elgin	652.4	19	0.927	608	21,900	0.031	0.037	729	1-1056
Flint	740.8	37	0.990	691	24,400	0.027	0.033	790	1-1155
Greeley	927.2	37	1.108	865	30,500	0.022	0.026	908	1-1155

Note:

Conductor temperature at 75°, ambient temperature 25°C, emissivity 0.5, wind 2 ft/sec, in sun.

Conductor Information for ACAR Conductors

SIZE	STRANDING	DIAMETER	WEIGHT PER 1000 FT	RATED STRENGTH	RESISTANCE		ALLOWABLE AMPACITY ¹	SAG10® CHART NUMBER
					OHMS PER 1000 FT			
KCMIL	AAC/AAAC	IN	LBS	LBS	DC @ 20°C	AC @ 75°C	AMPS	
355.0	12/7	0.683	332	8,500	0.051	0.062	519	1-1196
465.9	12/7	0.783	436	11,000	0.039	0.048	616	1-1196
503.6	12/7	0.814	471	11,900	0.036	0.044	646	1-1196
653.1	12/7	0.927	611	15,400	0.028	0.034	760	1-1196
739.8	30/7	0.990	693	15,300	0.024	0.030	831	1-1203
739.8	18/19	0.990	692	18,800	0.025	0.031	814	1-1206
853.7	30/7	1.063	799	17,500	0.021	0.026	907	1-1203
853.7	18/19	1.063	798	21,500	0.022	0.027	890	1-1206
927.2	30/7	1.108	868	19,000	0.019	0.024	955	1-1203
927.2	18/19	1.108	867	23,400	0.020	0.025	936	1-1206
1024.5	30/7	1.165	959	20,900	0.017	0.022	1,015	1-1203
1024.5	18/19	1.165	958	25,800	0.018	0.023	995	1-1206
1081.0	30/7	1.196	1,012	22,100	0.016	0.021	1,048	1-1203
1081.0	18/19	1.196	1,011	27,200	0.017	0.021	1,028	1-1206
1109.0	30/7	1.212	1,038	22,700	0.016	0.020	1,065	1-1203
1109.0	18/19	1.212	1,037	27,900	0.017	0.021	1,044	1-1206
1172.0	30/7	1.246	1,097	24,000	0.015	0.019	1,101	1-1203
1172.0	18/19	1.246	1,096	29,500	0.016	0.020	1,080	1-1206
1197.0	30/7	1.259	1,121	24,500	0.015	0.019	1,115	1-1203
1197.0	18/19	1.259	1,119	30,200	0.016	0.019	1,094	1-1206
1280.0	30/7	1.302	1,199	26,200	0.014	0.018	1,160	1-1203
1280.0	18/19	1.302	1,197	32,200	0.015	0.018	1,139	1-1206
1361.0	42/19	1.344	1,274	30,300	0.013	0.017	1,196	1-1125
1527.0	42/19	1.424	1,429	33,600	0.012	0.015	1,314	1-1125
1703.0	42/19	1.504	1,594	37,500	0.011	0.014	1,363	1-1125
1933.0	42/19	1.602	1,809	42,500	0.009	0.012	1,465	1-1125
2267.0	42/19	1.735	2,142	49,900	0.008	0.011	1,594	1-1125
2339.0	42/19	1.762	2,210	51,500	0.008	0.011	1,622	1-1125
2493.0	72/19	1.821	2,357	50,400	0.007	0.010	1,687	1-1235
2493.0	54/37	1.821	2,355	57,600	0.007	0.010	1,670	1-1105

Note:

Conductor temperature at 75°, ambient temperature 25°C, emissivity 0.5, wind 2 ft/sec, in sun.

Installation Instructions

Non-Adjustable Quick Compress Dead Ends for ACSR Conductors (VES/HES and VED/HED Series)

1. Prior to making any connections, the conductor must be wire brushed. If the conductor is weathered or blackened, carefully unlay the aluminum strands for a distance equal to the compression length of the dead end barrel. Clean the aluminum strands thoroughly with a wire brush. An alternate way to thoroughly clean the aluminum oxidation from the conductor is to use the ConductaClean® system. Straighten several feet of conductor removing set caused by reel.
2. Mark the conductor from the end, a distance equal to the length of compression barrel.

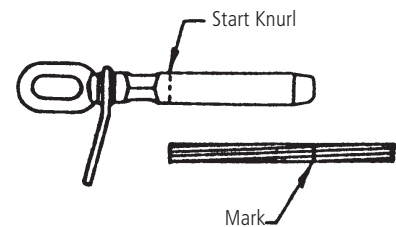

3. Cut the aluminum strands back a distance equal to the length of the core grip plus 1/4 inch (6 mm). Do not nick the steel strands. File burrs as necessary for ease of insertion.



4. Insert the steel core into the core grip. Do not twist the core grip while inserting core wire.



5. Insert the core grip and conductor into the compression barrel. Be sure the conductor is inserted beyond the mark on the conductor.

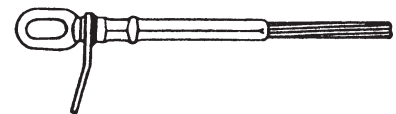

6. To compress the aluminum barrel, select the proper die size as stamped on the barrel.
7. The dead end will bow during compression unless care is taken to have 15 feet (4.5 m) of the conductor supported straight out from the end of the dead end. The weight of the conductor should not hang unsupported when compressing.
8. Make the initial compression at the "start knurl" and continue making compressions to the end of the dead end body. Complete die closure is required for each compression. Overlap the previous compression by approximately 1/4 die bite. It is recommended that die grooves be well lubricated with a lightweight oil. Oil coating should be maintained during entire compression operation.
9. Remove flash, if any, with a file or an abrasive cloth.

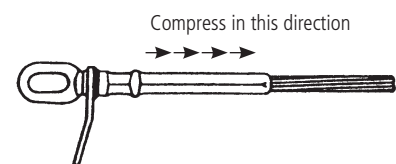

CAUTION: Follow installation instructions carefully. Improper installation can result in mechanical failure of the cable system and possible injury to persons handling or in the vicinity of the cable systems.

Installation Instructions

Non-Adjustable Quick Compress Dead Ends for AAC, AAAC and ACAR Conductors

1. Prior to making any connections, the conductor must be wire brushed. If the conductor is weathered or blackened, carefully unlay the aluminum strands for a distance equal to the compression length of the dead end barrel. Clean the aluminum strands thoroughly with a wire brush. An alternate way to thoroughly clean the aluminum oxidation from the conductor is to use the ConductaClean® system. Straighten several feet of conductor removing set caused by reel.
2. Mark the conductor from the end, a distance equal to the length of compression barrel.

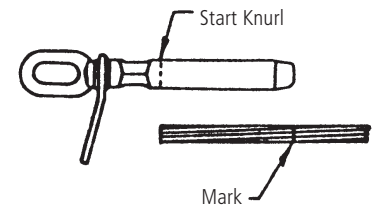

3. File burrs or sharp edges off the aluminum strands as necessary for ease of insertion.
4. Insert the conductor into the compression barrel. Be sure the conductor is inserted beyond the mark on the conductor.

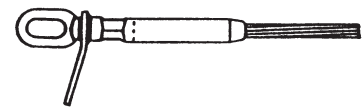

5. To compress the aluminum barrel, select the proper die size as stamped on the barrel.
6. The dead end will bow during compression unless care is taken to have 15 feet (4.5 m) of the conductor supported straight out from the end of the dead end. The weight of the conductor should not hang unsupported when compressing.
7. Make the initial compression at the "start knurl" and continue making compressions to the end of the dead end body. Complete die closure is required for each compression. Overlap the previous compression by approximately 1/4 die bite. It is recommended that die grooves be well lubricated with a lightweight oil. Oil coating should be maintained during entire compression operation.
8. Remove flash, if any, with a file or an abrasive cloth.

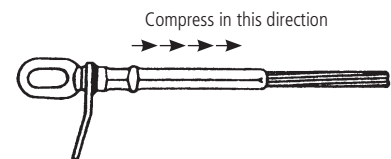

Installation Instructions for Adjustable Quick Compress Dead Ends for ACSR, AAC, AAAC and ACAR Conductors

1. To install, follow steps 1-9 on previous page for ACSR or 1-8 above for AAC, AAAC and ACAR.

To Adjust Dead Ends

2. Loosen rear nut jam.
3. Rotate clevis or eye for proper sag.
4. Tighten rear jam nut.

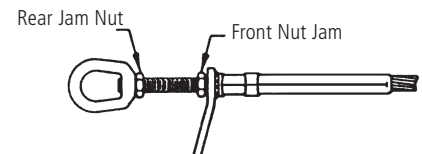
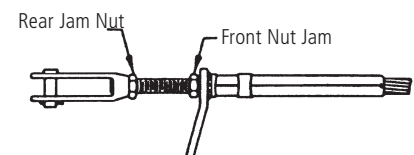

CAUTION: Follow installation instructions carefully. Improper installation can result in mechanical failure of the cable system and possible injury to persons handling or in the vicinity of the cable systems.

Installation Instructions

Non-Adjustable Quick Compress Dead Ends for Alumoweld® and Steel Ground Wire

1. Serve the conductor, prior to cutting, to help maintain the round contour. File burrs or sharp edges off the conductor as necessary for ease of insertion.
2. Straighten several feet of conductor removing set caused by reel.
3. Prior to making connections, the conductor must be clean. If the conductor is weathered or blackened, clean strands thoroughly with wire brush.
4. Mark the conductor for a distance from the end equal to the length of compression of the aluminum barrel.

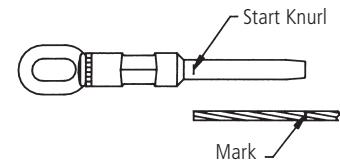

5. Insert the conductor into the compression barrel. Be sure the conductor is inserted beyond the mark on the conductor.
6. Select the proper die size to compress the aluminum barrel. The die size indicated on the aluminum barrel should match that indicated on the compression dies.
7. The dead end will bow during compression unless reasonable care is taken to have about 15 feet of the conductor supported straight out from the end of the dead end such that the weight of the conductor does not hang unsupported from the end of the dead end when compressing.

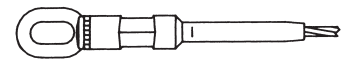

8. It is recommended that die grooves be well lubricated with a light weight oil. Oil coating should be maintained during entire compression operation.
9. Make initial compression starting at the start knurl. Continue making compressions to the end of the dead end barrel. Overlapping the previous compression by approximately 1/4 die bite. Complete die closure is required for each compression.
10. Compressed portion of the dead end should have a smooth uniform appearance. Remove flash, if present, with file or emery cloth.

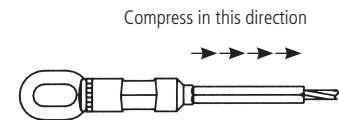

CAUTION: Follow installation instructions carefully. Improper installation can result in mechanical failure of the cable system and possible injury to persons handling or in the vicinity of the cable systems.

Installation Instructions for Quick Compress Joints for AAC, AAAC, ACAR Conductors, Alumoweld® and Steel Ground Wire

1. Prior to making any connections, the conductor must be clean. If the conductor is weathered or blackened, carefully unlay the aluminum strands for a distance equal to half the length of the joint. Clean the aluminum strands thoroughly with a wire brush. An alternate way to thoroughly clean the aluminum oxidation from the conductor is to use the ConductaClean® system. Straighten several feet of conductor removing set caused by reel.

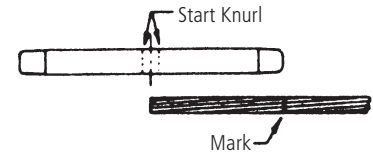

2. Mark the conductor from the end, a distance equal to half the length of the joint.

3. File burrs or sharp edges as necessary for ease of insertion.

4. Insert the conductor into one end of the joint. Be sure the conductor is inserted to the mark on the conductor.

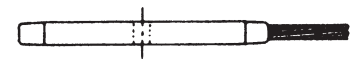

5. To compress, select the proper die size as stamped on the joint.

6. The joint will bow during compression unless care is taken to have a minimum of 15 feet (4.5 m) of the conductor supported on both sides.

7. Make the initial compression at the 'start knurl' and continue compressing toward one end of the joint. Complete die closure is required for each compression. Overlap the previous compression by approximately 1/4 die bite. It is recommended that die grooves be well lubricated with a lightweight oil. Oil coating should be maintained during entire compression operation.

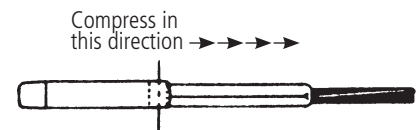

8. Repeat Steps #1 through #7 with the other side to complete the joint.

9. Remove flash, if any, with a file or an abrasive cloth.

CAUTION: Follow installation instructions carefully. Improper installation can result in mechanical failure of the cable system and possible injury to persons handling or in the vicinity of the cable systems.

Installation Instructions

Quick Compress Joints for ACSR Conductors

1. Prior to making any connections, the conductor must be wire brushed. If the conductor is weathered or blackened, carefully unlay the aluminum strands for a distance equal to half the length of the joint. Clean the aluminum strands thoroughly with a wire brush. An alternate way to thoroughly clean the aluminum oxidation from the conductor is to use the ConductaClean® system. Straighten several feet of conductor removing set caused by reel.

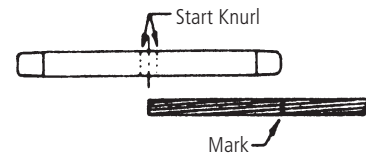

2. Mark the conductor from the end, a distance equal to half the length of the joint.

3. Cut the aluminum strands back a distance equal to the length of the core grip plus 1/4 inch (6 mm). Do not nick the steel strands. File burrs as necessary for ease of insertion.

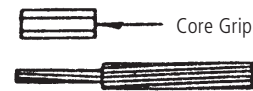

4. Insert the steel core into the core grip. Do not twist the core grip while inserting core wire.



5. Insert the core grip and conductor into one end of the joint. Be sure the conductor is inserted to the mark on the conductor.

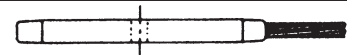

6. To compress, select the proper die size as stamped on the joint.

7. The joint will bow during compression unless care is taken to have a minimum of 15 feet (4.5 m) of the conductor supported on both sides.

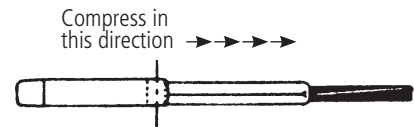

8. Make the initial compression at the 'start knurl' and continue compressing toward one end of the joint. Complete die closure is required for each compression. Overlap the previous compression by approximately 1/4 die bite. It is recommended that die grooves be well lubricated with a lightweight oil. Oil coating should be maintained during entire compression operation.

9. Repeat Steps #1 through #8 with the other side to complete the joint.

10. Remove flash, if any, with a file or an abrasive cloth.

CAUTION: Follow installation instructions carefully. Improper installation can result in mechanical failure of the cable system and possible injury to persons handling or in the vicinity of the cable systems.

Installation Instructions

Standard Compression and Quick Compress Repair Sleeves on ACSR, AAC, AAAC and ACAR Conductors

1. Compression Repair Sleeves can be used to restore the electrical and mechanical integrity of a conductor when no more than 1/2 of the aluminum strands are damaged.
2. Mark the conductor from the damaged area 1/2 the length of the repair sleeve.
3. Select die size for compressing the repair sleeve. The die size on the die and the die size marked on the repair sleeve must be the same.
4. Prior to making connections, the groove of the aluminum accessories and the conductor must be clean. If the conductor is weathered or blackened, clean strands thoroughly with wire brush. Check accessory groove for foreign particles, removing if present.
5. Coat the aluminum conductor with AFL Filler Compound (AFC) over the length to be covered by the repair sleeve.

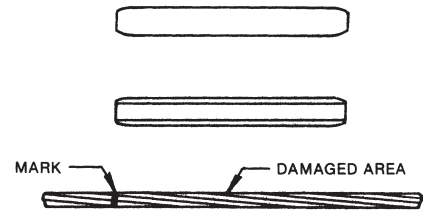

6. Place the repair sleeve groove on the conductor adjacent to damaged area and slide other half (keeper) in place.



7. Slide repair sleeve assembly over the damaged area to the mark on the conductor.
8. Make the initial compression over the center portion of the repair sleeve. Make the second compression on one end overlapping the initial compression by 1/4 die bite. Make the third compression on the opposite end, overlapping the initial compression by 1/4 die bite. Continue making compressions to one end of the repair sleeve overlapping the previous compression by 1/4 die bite. Complete die closure is required for each compression. Go back and complete the compression on the opposite end.
9. The compressed repair sleeve should have a smooth uniform appearance. Remove flash, if present, with file or emery cloth.

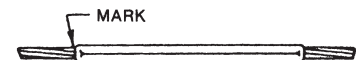

CAUTION: Follow installation instructions carefully. Improper installation can result in mechanical failure of the cable system and possible injury to persons handling or in the vicinity of the cable systems.

Installation Instructions

Standard Compression and Quick Compress Jumper Connectors on ACSR, AAC, AAAC, ACAR, Alumoweld® and Steel Ground Wire Conductor

1. Measure back from each conductor end and mark at a distance equal to 1/2 the length of the aluminum jumper connector.
2. File burrs or sharp edges off the aluminum strands as necessary for ease of insertion.
3. Prior to making connections, the conductor must be wire brushed and accessory bores must be clean. If the conductor is weathered or blackened, carefully unlay aluminum strands for a distance equal to or greater than 1/2 the length of the aluminum jumper connector and clean strands thoroughly with wire brush. An alternate way to thoroughly clean the aluminum oxidation from the conductor is to use the ConductaClean® system. Check accessory bore for foreign particles, removing if present.

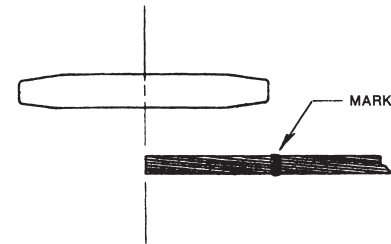

4. Inject AFL Filler Compound (AFC) into each end of jumper connector and on the conductor to insure that excess compound will be forced from the jumper connector when compressions are completed. Insert conductor ends into the jumper connector. If the mark on the conductor is not at the end of the jumper connector, and there is resistance to further entry, twist the jumper connector on the conductor. This will work the compound between conductor strands and bleed air from the jumper connector.
5. Select die size for compressing jumper connector. The die size on die and die size marked on aluminum jumper connector must be the same.
6. The jumper connector will bow during compression unless reasonable care is taken to have about 15 ft. (4.5 m) of the conductor supported straight out from both ends of the jumper connector such that the weight of the conductor does not hang unsupported from the end of the jumper connector when compressing.

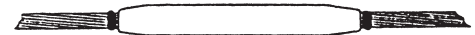

7. Compress jumper connector full length making initial compression over center stop. Overlap each successive compression by approximately 1/4 die bite. Complete die closure is required for each compression.
8. Compressed jumper connector should have a smooth uniform appearance. Remove flash, if present, with file or emery cloth.

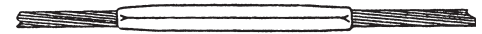

CAUTION: Follow installation instructions carefully. Improper installation can result in mechanical failure of the cable system and possible injury to persons handling or in the vicinity of the cable systems.

Installation Instructions

Standard and Quick Compress Compression Terminals

(These instructions are not for HiTemp® Conductors)

1. Prior to making any connections, the conductor must be clean. For new conductor, the outside diameter shall be wire brushed to remove the aluminum oxidation. If the conductor is weathered or blackened, carefully unlay the aluminum strands for a distance equal to the compression length of the terminal. Clean all of the aluminum strands thoroughly with a wire brush. An alternate way to thoroughly clean the aluminum oxidation from the conductor is to use the ConductaClean® system.
2. Mark the conductor from the end, a distance equal to the compression length of the terminal.

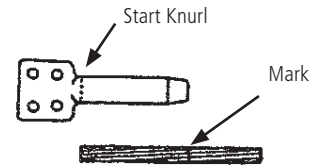

Quick Compress:

- 3a. Insert the conductor into the terminal. Be sure the conductor is inserted to the mark on the conductor. The terminal comes pre-filled with compound from the factory.



Standard Compression:

- 3b. Inject sufficient AFL Filler Compound (AFC) in the end of the terminal bore and on the conductor to ensure that excess compound will be visible at terminal end when barrel is completely compressed. See chart below for proper amount of AFC required for each terminal size.

AFC Filler Compound Required

PARTIAL TERMINAL CATALOG NUMBER	LB.	GRAMS (G)
5172., 5672., 5872.	0.01	5
5173., 5673., 5873.	0.01	5
5174., 5674., 5874.	0.02	9
5175., 5675., 5875.	0.02	9
5176., 5676., 5876.	0.02	9
5106., 5606., 5806.	0.02	9
5109., 5609., 5809.	0.02	9
5110., 5610., 5810.	0.03	14
5111., 5611., 5811.	0.03	14
5112., 5612., 5812.	0.03	14
5113., 5613., 5813.	0.03	14
5120., 5620., 5820.	0.04	18
5124., 5624., 5824.	0.05	23
5127., 5627., 5827.	0.06	27
5130., 5630., 5830.	0.09	41
5134., 5634., 5834.	0.12	54
5136., 5636., 5836.	0.15	68
5138., 5638., 5838.	0.17	77
5140., 5640., 5840.	0.2	91
5142., 5642., 5842.	0.24	109
5144., 5644., 5844.	0.28	127
5148., 5648., 5848.	0.32	145

→
Continued

CAUTION: Follow installation instructions carefully. Improper installation can result in mechanical failure of the cable system and possible injury to persons handling or in the vicinity of the cable systems.

Installation Instructions (cont.)

Standard and Quick Compress Compression Terminals (These instructions are not for HiTemp® Conductors)

4. To compress, select the proper die size as stamped on the jumper connector.
5. Compress the terminal, beginning at the "start knurl." Continue compressing toward the end of the terminal. Complete die closure is required for each compression. Overlap the previous compression by approximately 1/4 die bite. It is recommended that die grooves be well lubricated with a lightweight oil. Oil coating should be maintained during entire compression operation. (Other acceptable mediums that can be used instead of oil are wax, soap or plastic bag the terminal was shipped in.)
6. Remove flash, if any, with a file or an abrasive cloth.

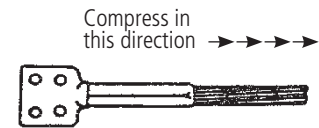

To Attach Terminal Connector to Dead End or Tee Tap

7. Clean contact surface of pads to be connected by wire brushing thoroughly and immediately coating with a thin film of No. 2 Electrical Joint Compound (EJC). **DO NOT USE AFC.**
8. Bolt terminal to dead end pad. Partially tighten all bolts and then re-tighten each bolt to the recommended torque:

Aluminum 1/2" bolts - 25 lb-ft (34 N.m)
Stainless Steel 1/2" bolts - 40 lb-ft (54 N.m)

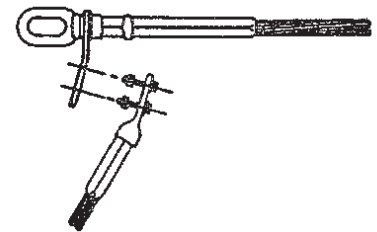

CAUTION: Follow installation instructions carefully. Improper installation can result in mechanical failure of the cable system and possible injury to persons handling or in the vicinity of the cable systems.

Installation Instructions

Quick Compress Open Run Tee Tap for ACSR, AAC, AAAC and ACAR Conductors

1. Remove the keeper.
2. To compress, select the proper die size as stamped on the jumper connector.
3. Prior to making connections, the groove of the aluminum accessories and the conductor must be clean. If the conductor is weathered or blackened, clean strands thoroughly with wire brush or abrasive cloth. Check the accessory groove for foreign particles and remove if present.
4. Coat the aluminum conductor with AFL Filler Compound (AFC) over the length to be covered by the tee tap.

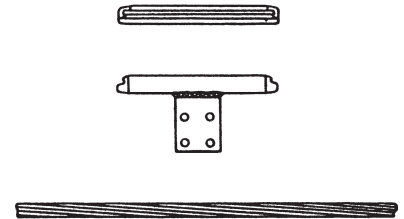

5. Place run groove on conductor and slide the keeper in place.

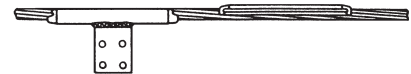

6. Make initial compression on either side of run starting at the "start knurl". Make the second compression on the opposite end of the run at the "start knurl". Continue making compressions to the end of the tee, overlapping the previous compression by approximately 1/4 die bite. Go back and complete the compression on the opposite end.
7. Compressed portion of tee should have a smooth, uniform appearance. Remove flash, if present, with file or abrasive cloth.

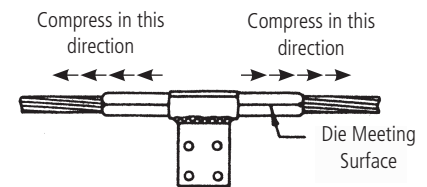

Installation Instructions

Quick Compress Open Run Tee Connector for ACSR, AAC, AAAC and ACAR Conductors

1. Install run tee using steps 1 - 7 above.
2. Insert conductor full depth into branch bore and mark conductor at end of branch. Remove conductor after marking.
3. Inject sufficient AFC in the end of the branch bore and on the conductor to insure that excess compound will be visible at the branch end when completely compressed.
4. Insert the conductor into the branch to the mark on the conductor.
5. Make initial compression starting at the "start knurl". Continue making compressions to mouth of the branch overlapping the previous compression by approximately 1/4 die bite.
6. Compressed portion of the branch should have a smooth, uniform appearance. Remove flash, if present, with file or abrasive cloth.

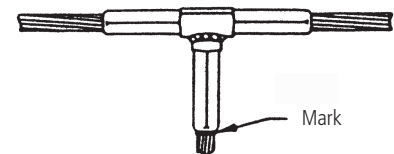

CAUTION: Follow installation instructions carefully. Improper installation can result in mechanical failure of the cable system and possible injury to persons handling or in the vicinity of the cable systems.

Index

ACS Series		GWDE Series for Ground Wire	253
ACSR Conductor	165	GWJ Series for Ground Wire	256
AAAC and ACAR Conductors	229	HED Series	
ACSE Series for AAC Conductor	201	ACSR Conductor	162
AES Series		AAAC and ACAR Conductor	227
ACSR Conductor	168	HEDE Series for AAC Conductor	199
AAAC and ACAR Conductor	231	HES Series	
AESE Series for AAC Conductor	203	ACSR Conductor	159
CJ Series		AAAC and ACAR Conductor	225
ACSR Conductor	171	HESE Series for AAC Conductor	197
AAAC and ACAR Conductors	233	Installation Instructions	
CJE Series for AAC Conductor	205	Compression Joints	
CJER Series for AAC Conductor	207	ACSR Conductor	269
CJR Series		AAC, AAAC, ACAR Conductors & Steel Gnd Wire	268
ACSR Conductor	173	Dead Ends	
AAAC and ACAR Conductors	235	ACSR Conductor	265
Compression Joints		AAC, AAAC, ACAR Conductors & Steel Gnd Wire	266
ACSR Conductors	171	Adjustable Dead Ends	266
AAC Conductors	205	Alumoweld and Steel Ground Wire	267
AAAC and ACAR Conductors	233	Jumper Connectors	271
Ground Wire	256	Repair Sleeves	270
Conductor InformationSee Reference Material	Tee Connectors, Open Run	274
Dead Ends, Compression		Tee Taps, Open Run	274
Single Tongue		Terminal Connectors	272
ACSR Conductor	159	JC Series	
AAC Conductor	197	ACSR Conductor	177
AAAC and ACAR Conductor	225	AAC Conductor	211
Ground Wire	253	AAAC and ACAR Conductor	239
Double Tongue		Jumper Connectors	
ACSR Conductor	162	ACSR Conductor	177
AAC Conductor	199	AAC Conductor	211
AAAC and ACAR Conductor	227	AAAC and ACAR Conductor	239
Adjustable Clevis		JumpersSee Terminals
ACSR Conductor	165	Pad DimensionsSee Reference Material
AAC Conductor	201	Quick Reference Charts	
AAAC and ACAR Conductor	229	ACSR Conductor	152
Adjustable Eye		AAC Conductor	154
ACSR Conductor	168	AAC and ACAR Conductor	155
AAC Conductor	203		
AAAC and ACAR Conductor	231		

continued
→

Index (cont.)

Reference Material

Adjustable Steel Clevis Dimensions	258
Adjustable Steel Eye Dimensions	258
Bolt Sizes and Recommended Torque	257
Conductor Information for ACSR Conductor	259
Conductor Information for AAC Conductor	261
Conductor Information for AAAC Conductor	263
Conductor Information for ACAR Conductor	264
NEMA Standard Pad Sizes	257
Steel Eye Dimensions	257

Repair Sleeves

ACSR Conductor	175
AAC Conductor	209
AAAC and ACAR Conductor	237

RS Series

ACSR Conductor	175
AAC Conductor	209
AAAC and ACAR Conductor	237

Sleeves. See Compression Joints or Jumper Connectors

T45 Series

ACSR Conductor	185
AAC Conductor	217
AAAC and ACAR Conductor	245

Tee Connectors, Open Run

ACSR Conductor	191
AAC Conductor	221
AAAC and ACAR Conductor	249

Tee Taps, Open Run

ACSR Conductor	193
AAC Conductor	223
AAAC and ACAR Conductor	250

Terminals

15°	
ACSR Conductor	182
AAC Conductor	215
AAAC and ACAR Conductor	243
45°	
ACSR Conductor	185
AAC Conductor	217
AAAC and ACAR Conductor	245

Terminals

90°	
ACSR Conductor	188
AAC Conductor	219
AAAC and ACAR Conductor	247
Straight	
ACSR Conductor	179
AAC Conductor	213
AAAC and ACAR Conductor	243

TF Series

ACSR Conductor	182
AAC Conductor	215
AAAC and ACAR Conductor	243

TN Series

ACSR Conductor	188
AAC Conductor	219
AAAC and ACAR Conductor	247

TS Series

ACSR Conductor	179
AAC Conductor	213
AAAC and ACAR Conductor	241

TTOC Series

ACSR Conductor	191
AAC Conductor	221
AAAC and ACAR Conductor	249

TTOP Series

ACSR Conductor	193
AAC Conductor	223
AAAC and ACAR Conductor	250

VED Series

ACSR Conductor	162
AAAC and ACAR Conductor	227

VEDE Series for AAC Conductor 199

VES Series

ACSR Conductor	159
AAAC and ACAR Conductor	225

VESE Series for AAC Conductor 197