

OPGW Double Dead End Wood Pole/H-Frame Configuration Assemblies

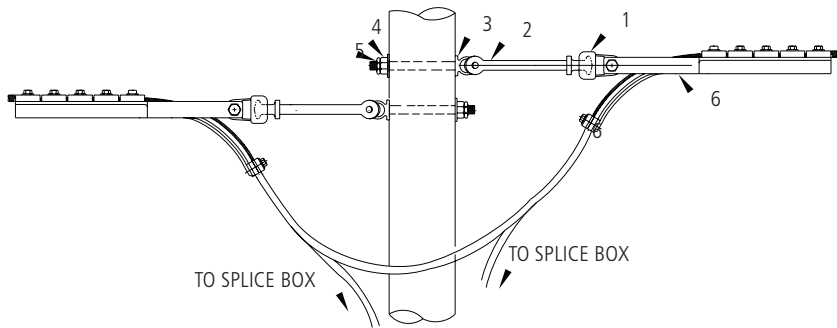

AFL NO.

OWPDD1

Assembly Code

DNOXXXX

Cable Spec. Number

Bill of Material

Item	Description	Material	AFL or Dwg. No.	Req'd	Remarks
1	Socket Eye	Galvanized Steel	SE-BDE	2	
2	Y-Clevis Ball Hot Link	Galvanized Steel	YCBHL	2	Pin Dia. = 0.75" (19 mm)
3	3/4" Shoulder Eye Bolt	Galvanized Steel	SEB-3/4-14	2	Length = 14"
4	3/4" Washer Nut	Galvanized Steel	WN-3/4	2	
5	3/4" MF Lock Nut	Galvanized Steel	LN-3/4	2	
6	Bolted Deadend (Included)	Aluminum	Determined by AFL	2	

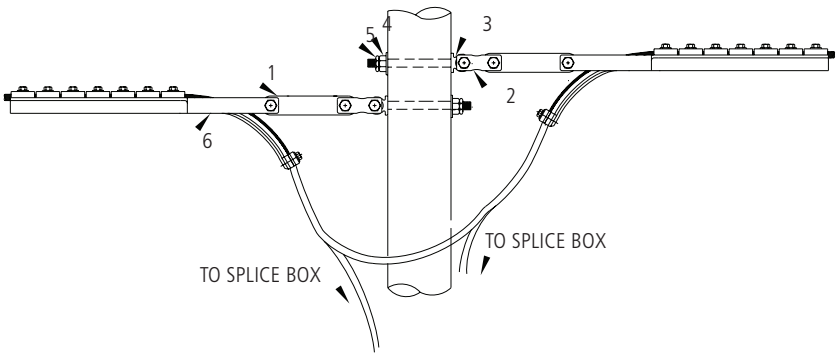

AFL NO.

OWPDD2

Assembly Code

DNOXXXX

Cable Spec. Number

Bill of Material

Item	Description	Material	AFL or Dwg. No.	Req'd	Remarks
1	Link Plate	Aluminum	ODEL10	2	
2	Y-Clevis Clevis	Galvanized Steel	YCC	2	Pin Dia. = 0.75" (19 mm)
3	3/4" Shoulder Eye Bolt	Galvanized Steel	SEB-3/4-14	2	
4	3/4" Washer Nut	Galvanized Steel	WN-3/4	2	
5	3/4" MF Lock Nut	Galvanized Steel	LN-3/4	2	
6	Bolted Deadend (Included)	Aluminum	Determined by AFL	2	

continued

OPGW Double Dead End Wood Pole/H-Frame Configuration Assemblies (cont.)

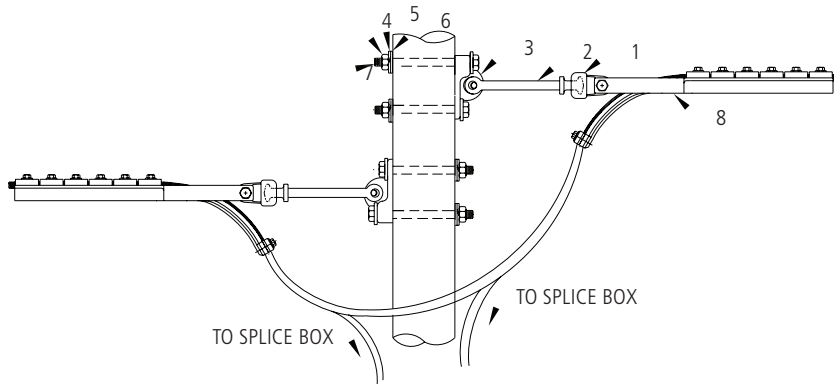

AFL NO.

OWPDD3

Assembly Code

- **DNOXXXX**

Cable Spec. Number

Bill of Material

Item	Description	Material	AFL or Dwg. No.	Req'd	Remarks
1	Socket Eye	Galvanized Steel	SE-BDE	2	
2	Y-Clevis Ball Hot Link	Galvanized Steel	YCBHL	2	Pin Dia. = 0.75" (19 mm)
3	Eye Plate	Galvanized Steel	EP1	2	
4	3/4" Lock Washer Nut	Galvanized Steel	LW-3/4	4	
5	3/4" Nut	Galvanized Steel	HN-3/4	4	
6	3/4" Flat Washer	Galvanized Steel	FW-3/4	4	
7	3/4" Through Bolt	Galvanized Steel	TB-3/4-14	4	Length = 14"
8	Bolted Deadend (Included)	Aluminum	Determined by AFL	2	

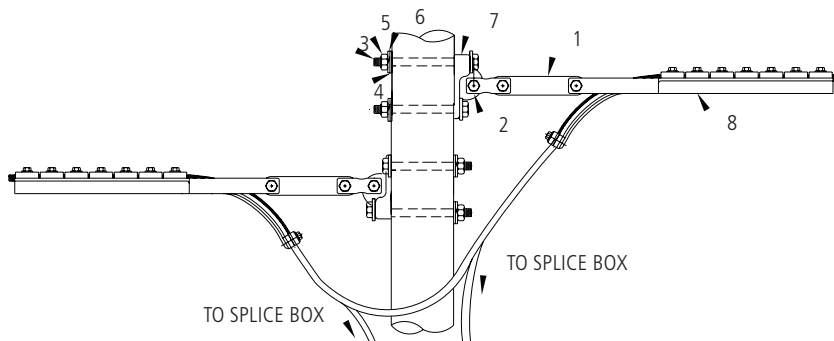

AFL NO.

OWPDD4

Assembly Code

- **DNOXXXX**

Cable Spec. Number

Bill of Material

Item	Description	Material	AFL or Dwg. No.	Req'd	Remarks
1	Link Plate	Aluminum	ODELP10	2	
2	Y-Clevis Clevis	Galvanized Steel	YCC	2	Pin Dia. = 0.75" (19 mm)
3	3/4" Through Bolt	Galvanized Steel	TB-3/4-14	4	Length = 14"
4	3/4" Flat Washer	Galvanized Steel	FN-3/4	4	
5	3/4" Nut	Galvanized Steel	HN-3/4	4	
6	3/4" Lock Washer	Galvanized Steel	LW-3/4	4	
7	Eye Plate	Galvanized Steel	EP1	2	
8	Bolted Deadend (Included)	Aluminum	Determined by AFL	2	

continued

OPGW Double Dead End Wood Pole/H-Frame Configuration Assemblies (cont.)

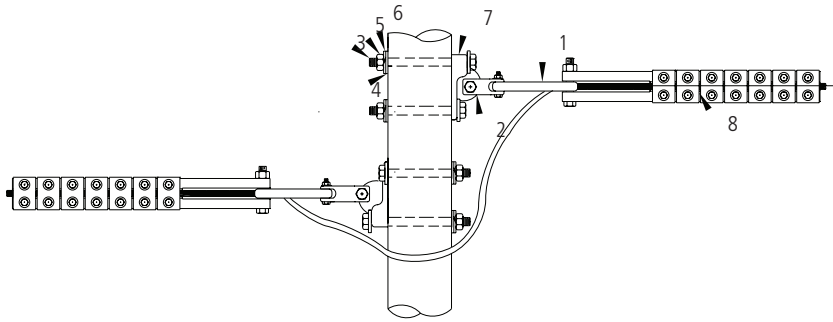

AFL NO.

OWPDD5

Assembly Code

DNOXXXX

Cable Spec. Number

Bill of Material

Item	Description	Material	AFL or Dwg. No.	Req'd	Remarks
1	Link Plate	Aluminum	ODEL P10	2	
2	Y-Clevis Clevis 90°	Galvanized Steel	YCC-90	2	Pin Dia. = 0.75" (19 mm)
3	3/4" Through Bolt	Galvanized Steel	TB-3/4-14	4	Length = 14"
4	3/4" Flat Washer	Galvanized Steel	FN-3/4	4	
5	3/4" Nut	Galvanized Steel	HN-3/4	4	
6	3/4" Lock Washer	Galvanized Steel	LW-3/4	4	
7	Eye Plate	Galvanized Steel	EP1	2	
8	Bolted Deadend (Included)	Aluminum	Determined by AFL	2	