

DOSSERT® TYPE PLHS-AA, PLHS-CH-AA

Slip or Fixed Bus Support

Can be used as a slip or fixed bus support or fixed support by being welded into position.

Material

Aluminum Alloy

Hardware

Galvanized steel hardware supplied for base mounting.

Notes

1. For base mounting dimensions and hardware see page 3 in the general catalog index.



PLHS-AA

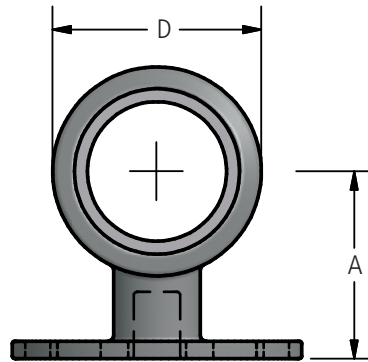
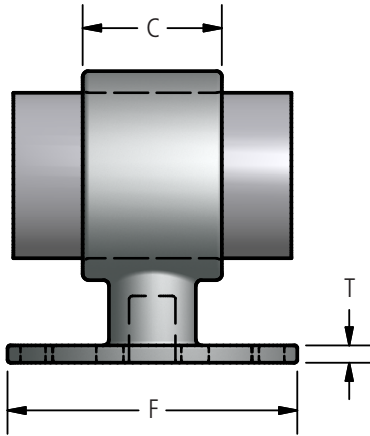

Ordering Information

CATALOG NUMBER		SPS	BOLT CIRCLE	DIMENSIONS IN INCHES				
STANDARD	WITH CHATTER SPRING			A	C	D	T	F
PLHS75-3-AA	PLHS75-3-CH-AA	3/4	3	2	1-1/4	1-9/16	3/8	4-1/4
PLHS75-5-AA	PLHS75-5-CH-AA	3/4	5	2-1/4	1-1/4	1-9/16	3/8	6-1/4
PLHS100-3-AA	PLHS100-3-CH-AA	1	3	2	1-1/4	1-7/8	3/8	4-1/4
PLHS100-5-AA	PLHS100-5-CH-AA	1	5	2-1/4	1-1/4	1-7/8	3/8	6-1/4
PLHS125-3-AA	PLHS125-3-CH-AA	1-1/4	3	2-1/4	1-1/2	2-1/4	3/8	4-1/4
PLHS125-5-AA	PLHS125-5-CH-AA	1-1/4	5	2-3/8	1-1/2	2-1/4	3/8	6-1/4
PLHS150-3-AA	PLHS150-3-CH-AA	1-1/2	3	2-1/2	1-1/2	2-5/8	3/8	4-1/4
PLHS150-5-AA	PLHS150-5-CH-AA	1-1/2	5	2-1/2	1-1/2	2-5/8	3/8	6-1/4
PLHS200-3-AA	PLHS200-3-CH-AA	2	3	2-3/4	2	3-1/4	3/8	4-1/4
PLHS200-5-AA	PLHS200-5-CH-AA	2	5	2-3/4	2	3-1/4	3/8	6-1/4
PLHS250-3-AA	PLHS250-3-CH-AA	2-1/2	3	3-1/8	2	3-11/16	3/8	4-1/4
PLHS250-5-AA	PLHS250-5-CH-AA	2-1/2	5	3-1/8	2	3-11/16	3/8	6-1/4
PLHS300-3-AA	PLHS300-3-CH-AA	3	3	3-5/8	2-1/2	4-1/2	3/8	4-1/4
PLHS300-5-AA	PLHS300-5-CH-AA	3	5	3-5/8	3	4-1/2	7/16	6-1/4
PLHS350-3-AA	PLHS350-3-CH-AA	3-1/2	3	4	3	5	7/16	4-1/4
PLHS350-5-AA	PLHS350-5-CH-AA	3-1/2	5	4	3	5	7/16	6-1/4
PLHS400-3-AA	PLHS400-3-CH-AA	4	3	4-1/2	3	5-9/16	3/8	4-1/4
PLHS400-5-AA	PLHS400-5-CH-AA	4	5	4-1/2	3	5-1/2	7/16	6-1/4
PLHS450-3-AA	PLHS450-3-CH-AA	4-1/2	3	4-3/4	3	6	7/16	4-1/4
PLHS450-5-AA	PLHS450-5-CH-AA	4-1/2	5	4-3/4	3	6	7/16	6-1/4
PLHS500-3-AA	PLHS500-3-CH-AA	5	3	5	3	6-9/16	7/16	4-1/4
PLHS500-5-AA	PLHS500-5-CH-AA	5	5	5	3	6-9/16	7/16	6-1/4
PLHS600-3-AA	PLHS600-3-CH-AA	6	3	5-1/2	4	7-5/8	7/16	4-1/4
PLHS600-5-AA	PLHS600-5-CH-AA	6	5	5-1/2	4	7-5/8	7/16	6-1/4