

Junior Expanded Beam Connector



The Junior Expanded Beam Fibre Optic Connectors have been designed for use in the most demanding harsh environment applications including military tactical communications, outside broadcast, petrochemical plant, mining and offshore systems.

The connectors are terminated using an epoxy-polish ferrule termination process with standard fibre optic termination tools and equipment. The terminated ferrules are simply inserted into the expanded beam housing and fixed in place via a spring and cover-plate. Ferrule alignment to the lenses is achieved automatically by the unique optical arrangement.

In the event of the connector suffering severe damage in use, the connector design enables replacement of the expanded beam insert, connector front body and grip ring without the need to re-terminate the fibres. Typically, an expanded beam insert can be replaced within 30 minutes in field conditions.

The Junior Expanded Beam connectors offer high performance, flexibility and cost effectiveness.

Features

- MIL-DTL-83526 specification
- Singlemode and multimode options
- Field terminable using standard termination
- Tools and equipment
- Field repairable: EB insert and shell parts replaceable/re-useable
- 1, 2 and 4 channel plugs and bulkheads
- Low insertion loss/high return loss
- 90° Backshell options for plug and bulkhead

Junior Expanded Beam Connector

Connector Specifications

Insertion loss	9/125 Fibre at 1310 nm / 1550 nm: -1.5 dB maximum (typical - 1.0 dB) 50/125 Fibre at 850 nm / 1300 nm: -1.0 dB maximum (typical - 0.7 dB)
Return loss	> -32 dB (typical - 40 dB)
Durability	3000 Matings minimum
Operating temperature	-55°C to +85°C
Storage temperature	-55°C to +85°C
Water immersion	15 m for 24 hrs
Free fall resistance	500 falls from 1.2 height
Vibration	20-500 Hz, 3 directions, 0.75 mm amplitude at 10 g acceleration
Bump	4000 bumps at 40 g acceleration
Crush resistance	6.7kN
Corrosion resistance	500 hours salt spray
Cable retention	1500 N (Cable dependent)
Weight (approx)	Aluminium: Plug: 120 g bulkhead: 110 g / 316 grade stainless steel: Plug: 180 g bulkhead: 200 g
Connector shell material / colour	Black anodised aluminium or 316 grade stainless steel Grip and boot: black or olive green

Optical Insert Arrangement

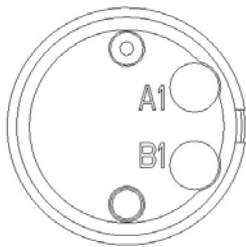

1736 - 2CH Optical

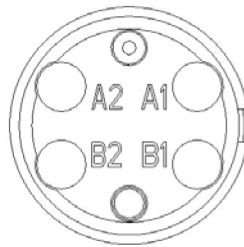

1702 - 4CH Optical



Junior Expanded Beam Connector

Plug Connector

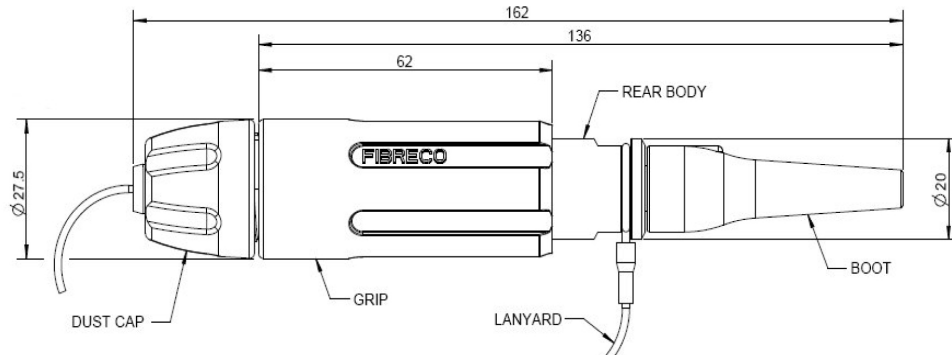

Bulkhead Connector D-Hole Mount

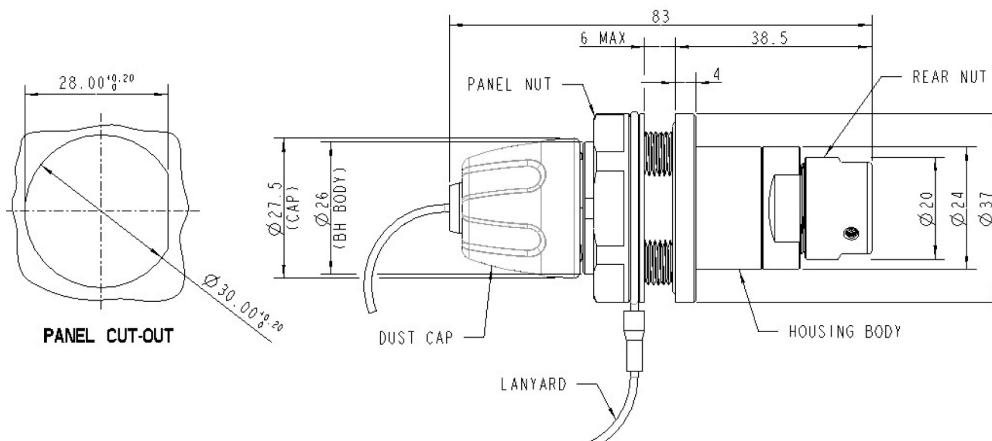

Bulkhead Connector Square-Flange Mount

