

Cleaning Data Center MPO/MTP Fiber Optic Connectors

Ever-escalating network bandwidths in present day data centers demand high performance, high density and pristine optical interconnects. This application note offers specific recommendations to meet this mission-critical need.

40G/100G Data Center Communications using Multimode, Multi-Fiber Connections

Within a data center, cable runs tend to be relatively short, enabling the use of multimode fiber (MMF) optical transmission systems. Specifically, IEEE 802.3bm (2015) defines the 40GBASE-SR4 40 Gbps Ethernet, as well as the 100GBASE-SR10 and the 100GBASE-SR4 100 Gbps Ethernet physical layer standards. These PHYs use parallel optics, either 4 fibers at 10.3125 Gbps to achieve 40 Gbps, 10 fibers at 10.3125 Gbps to achieve 100 Gbps, or 4 fibers at 25.78125 Gbps to achieve 100 Gbps (duplex operation doubles the fiber count). [The PHY rates differ from the payload rates because of 64B/66B encoding overhead.] These Ethernet PHYs offer a reach of up to 100 meters on OM3 laser optimized multi-mode fiber (LOMMF) and up to 150 meters on OM4 LOMMF, sufficient for many cabling applications inside today's data centers. Examples include links between servers and leaf switches, and between leaf and spine aggregation switches. OM3 and OM4 fibers are used with 850 nm Vertical-Cavity Surface-Emitting Laser (VCSEL) based transceivers, which historically have been less expensive than longer reach single mode optics. See Figure 1 for an example transceiver block diagram.

The new ISO/IEC OM5 wideband multimode fiber standard supports Short Wavelength Division Multiplexing (SWDM), specifically four wavelengths (850, 880, 910, and 940 nm), enabling the future use of a single WBMMF fiber to implement 40GBASE-SR4 and 100GBASE-SR4 on duplex LC cabling.

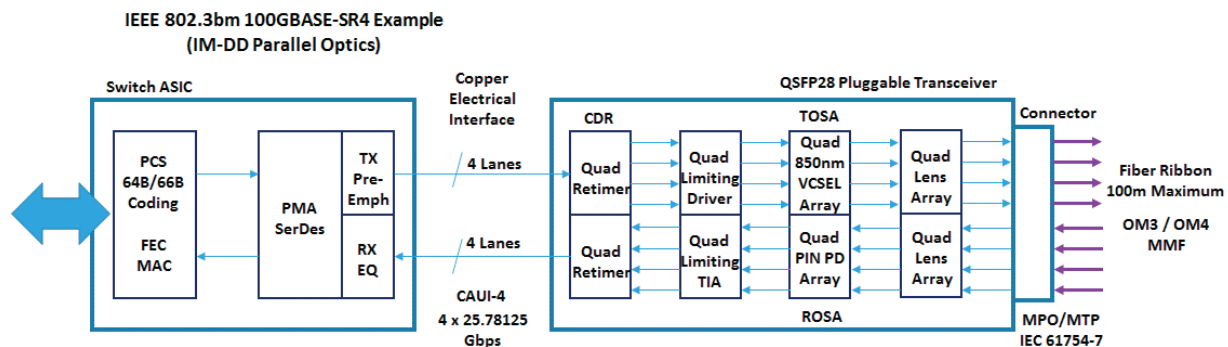

Figure 1: Example 100G Transceiver with MPO/MTP Connector

Multi-Fiber MPO/MTP Connectors

The need for high density data center connectivity has driven the widespread adoption of the Multiple-Fiber Push-On / Pull-Off (MPO) array connectors. The MPO connector (as well as the backward-compatible proprietary MTP® connector) is used with ribbon cable, typically 12 or 24 fibers in parallel, within outer housing dimensions of 12.6 mm by 7.7 mm. The IEC 61754-7 and TIA 604-5-D (also known as FOCIS 5) standards specify MPO connector intermateability. The MPO connector is ideal for high rate parallel optics applications such as 40, 50 and 100 Gbps short reach Ethernet, and will see dominant use in data centers for many years to come.

Cleaning and Inspecting MPO/MTP Connectors

AFL offers FUSEConnect® MPO splice-on connectors, including models with 50 µm core / 125 µm cladding OM3 ribbon cable intended to be fusion spliced. AFL also offers One-Click® MPO and NEOCLEAN-M connector cleaners designed to decontaminate MPO and MTP connector ferrule end-faces with a simple one-push action. CLETOP and OPTIPOP cassette cleaners from AFL can accommodate both male and female MPO connectors (i.e., with and without guide pins).

Optical connector ferrule end-faces tend to become contaminated with skin oils, grease, salts, moisture, fingerprints, dust, lint, grime, flux residues and uncured epoxies. AFL's FCC2 Enhanced Formula Connector Cleaner and Preparation Fluid can be used with the CLETOP and OPTIPOP-R cassette cleaners for a wet-to-dry method to address stubborn end-face debris, such as uncured epoxies.

Because fiber core diameters are so small (50 µm in the case of OM3 and OM4 fibers used with MPO connectors), contaminants invisible to the naked eye can affect system performance and even induce transmission failure; less severe contamination contributes to receiver bit errors by increasing optical loss and reflectance. In this context, a speck of dirt can be likened to a boulder in the middle of the road. It does not take much in terms of contamination to compromise the fidelity of a low loss multi-fiber connector.

AFL's FOCIS Flex system is ideal for MPO/MTP connector inspection, both PC (Physical Contact) and APC (Angled Physical Contact). A base and tip adapt the FOCIS Flex to these connectors (both single-row and multi-row), which are inspected through a bulkhead. Adjustment knobs on the base enable the scanning of each of the twelve fiber ends per row, and can support up to 8 rows (96 fibers total).

Bright Outlook

As data centers move to 40 and 100 Gbps short reach optical links and look forward to 200 and eventually 400 Gbps Ethernet, adhering to a strict Method of Procedure discipline of routine cleaning and inspecting high density array connectors during equipment installations and upgrades will be mandatory to meet ambitious network performance and reliability goals.



Image 1: Female (L) and Male MTP (R) Connectors



Image 2: OPTIPOP-R3 Refillable Cassette Cleaner for MPO/MTP Connectors