

THIS DRAWING AND ALL INFORMATION ON IT IS THE PROPERTY OF AFL. IT IS CONFIDENTIAL AND IT IS GIVEN TO YOU FOR A LIMITED PURPOSE AND MUST BE RETURNED UPON REQUEST. NEITHER THIS DRAWING OR ANY PART OF IT NOR ANY INFORMATION CONCERNING IT MAY BE COPIED, EXHIBITED, OR FURNISHED TO OTHERS NOR PHOTOGRAPHS TAKEN OF ANY ARTICLE FABRICATED OR ASSEMBLED FROM THE DRAWING WITHOUT THE CONSENT OF AFL.

ITEM NO:  
DWG. NO:

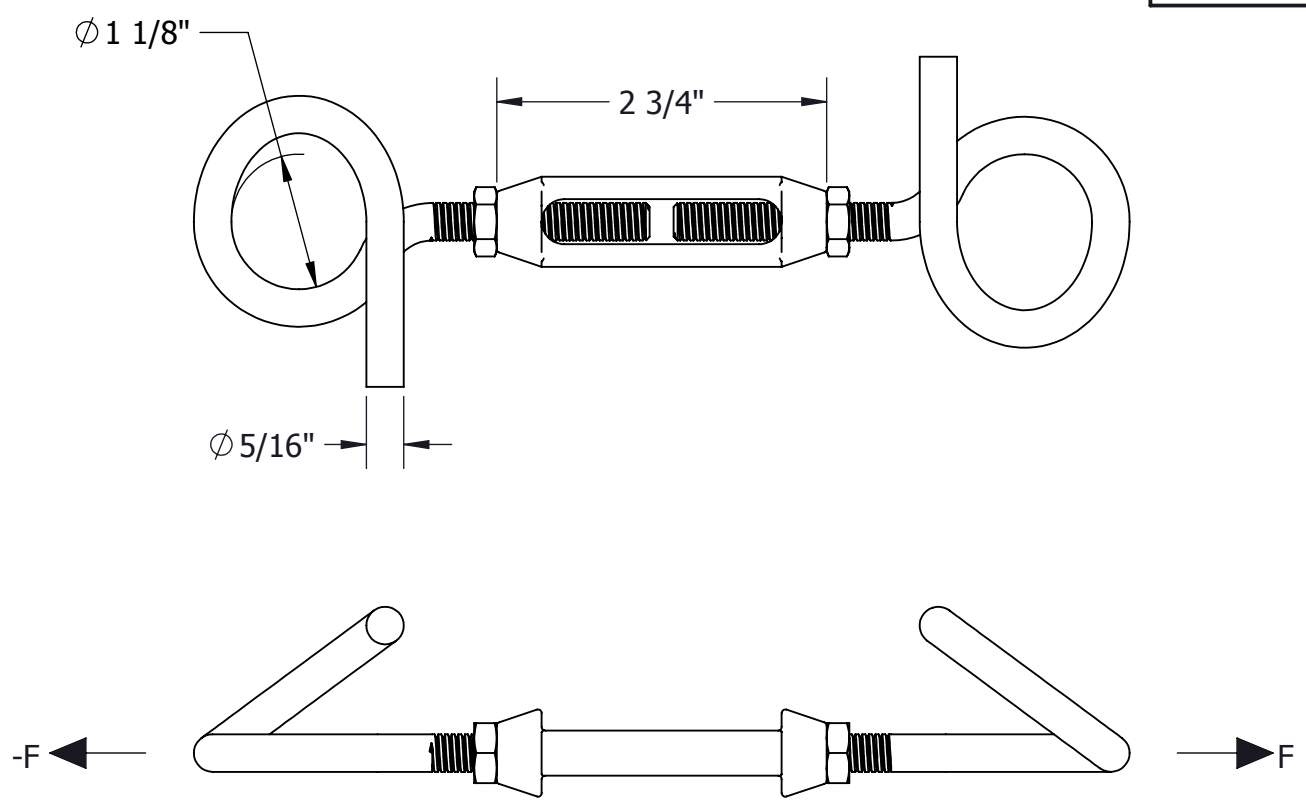

**MATERIAL:**  
 BODY - ALUMINUM BRONZE ASTM B30  
 LOOP, - STAINLESS TEEL  
 LOCK NUT - STAINLESS STEEL

**MECHANICAL RATINGS:**  
 MIN. ULTIMATE STRENGTH: 1,200 LBS

**(OPTIONAL) NOTE:**  
 APPLY LOC-TITE 272 (RED) TO LOOP THREADS AT FINAL ASSEMBLY  
 PRIOR TO TIGHTENING TO REDUCE MAINTENANCE FREQUENCY.

BOLTS SIZES	WRENCH/ SOCKET SIZES	TORQUE VALUES (FT-LBS)
1/4-20	3/8 HEX	8

WT: 0.2 LB

LOCATION	CONTRACT NO	CUST / CONTR
----------	-------------	--------------

REVISIONS					DRN BY:
REV	DESCRIPTION	DATE	BY	APR	HV
					DRN DATE:
					08/02/2017
					CHK BY:
					JL
					CHK DATE:
					8.2.17
					PA 2015.231.0



**TURNBUCKLE, LOOP TYPE, BRZ BODY, SS HDW**

REV	PART NO:	TBC-LP-A02	1 OF 1
0			