

ITEM NO

DWG NO
D-7343

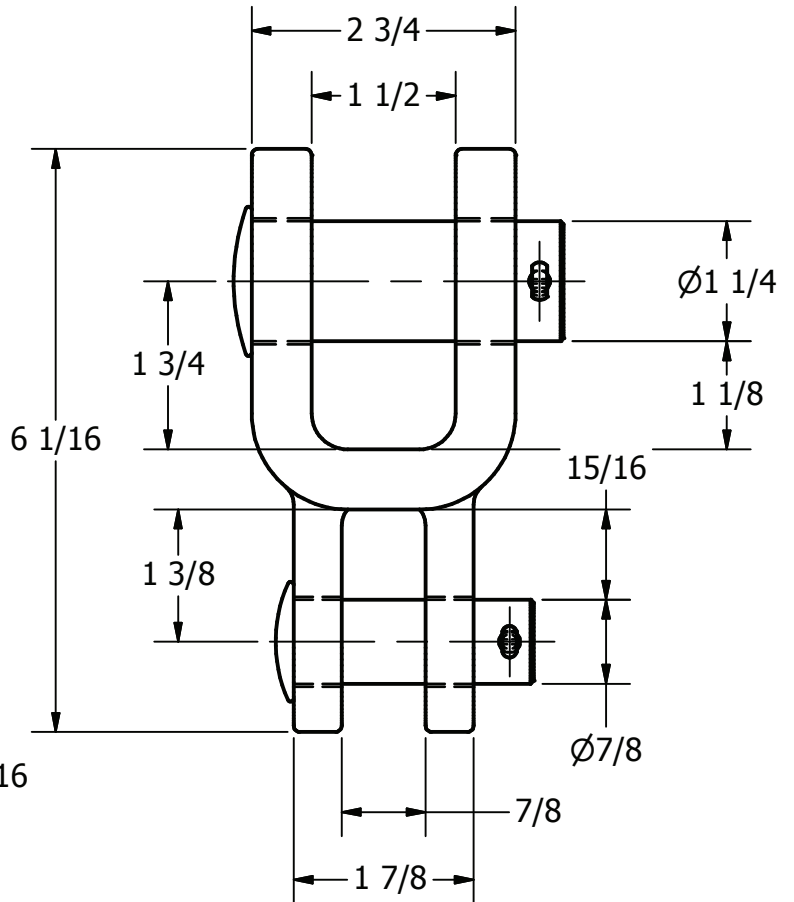
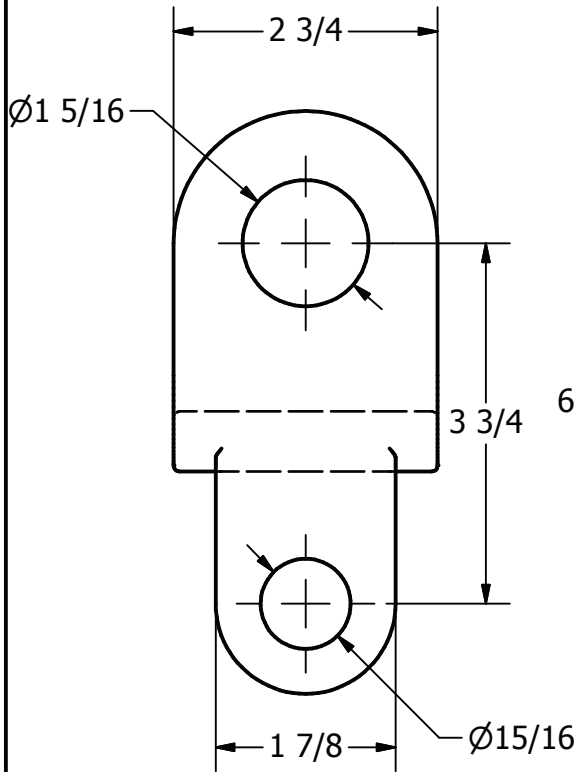
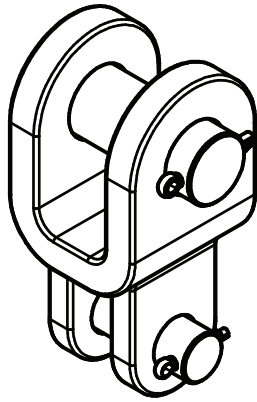

MATERIAL:
ALUMINUM BRONZE ASTM B30
CLEVIS PIN-GALVANIZED STEEL
COTTER KEY-STAINLESS STEEL

6.50 LBS

THIS DRAWING AND ALL INFORMATION ON IT IS THE PROPERTY OF AFL. IT IS CONFIDENTIAL AND IT IS GIVEN TO YOU FOR A LIMITED PURPOSE AND MUST BE RETURNED UPON REQUEST. NEITHER THIS DRAWING OR ANY PART OF IT NOR ANY INFORMATION CONCERNING IT MAY BE COPIED, EXHIBITED, OR FURNISHED TO OTHERS NOR PHOTOGRAPHS TAKEN OF ANY ARTICLE FABRICATED OR ASSEMBLED FROM THE DRAWING WITHOUT THE CONSENT OF AFL.

LOCATION					CONTRACT NO		CUST / CONTR																										
<table border="1"> <thead> <tr> <th colspan="5">REVISIONS</th> </tr> <tr> <th>REV</th> <th>DESCRIPTION</th> <th>DATE</th> <th>BY</th> <th>APR</th> </tr> </thead> <tbody> <tr> <td>4</td> <td>RE-DRAWN IN INVENTOR</td> <td>1-28-10</td> <td>LK</td> <td>EP</td> </tr> <tr> <td> </td> <td> </td> <td> </td> <td> </td> <td> </td> </tr> <tr> <td> </td> <td> </td> <td> </td> <td> </td> <td> </td> </tr> </tbody> </table>					REVISIONS					REV	DESCRIPTION	DATE	BY	APR	4	RE-DRAWN IN INVENTOR	1-28-10	LK	EP											DRN BY: BB DRN DATE: 3-31-08 CHK BY: BB CHK DATE: 3-31-08			
REVISIONS																																	
REV	DESCRIPTION	DATE	BY	APR																													
4	RE-DRAWN IN INVENTOR	1-28-10	LK	EP																													
					LINK, DOUBLE CLEVIS																												
					REV 4	DCL88-125		1 OF 1																									